

1990 Chevrolet Pickup K1500

WIRING DIAGRAMS 1990 Wiring Diagrams General Motors Corp.

WIRING DIAGRAMS

COMPONENT LOCATOR:

ABS MODULE	E 20
ALD. CONN (DIESEL)	C 8
ALD. CONN (GAS)	D 4
ALTERNATOR	C 3
AUDIO ALARM MODULE	C 20
AUXILIARY BATTERY RLY	A 1
BACK-UP LT SW	E 19
BEAM SEL SW	A 18
BLOWER SW (W/O A/C)	A 25
CLUTCH SW (M/T)	B 3
CONVENIENCE CENTER	D-E 13-14
COOLANT FAN RLY	C 3
COURTESY LTS	D-E 23
CRUISE CONTROL MODULE	E 4
DEFOG CONTROL	E 4
CHIMMER SW	B 16
DIR FLASHER	A 17
DIR/HAZ SW	A-B 19
ELECTRONIC CONTROL MODULE (ECM) (DIESEL)	A 8-11
ELECTRONIC CONTROL MODULE (ECM) (GAS)	A 4-6
FOG LT RLY	D 1
FOG LT SW	D 1
FRONT AXLE SW	C 18
FUEL PUMP RLY (DIESEL)	C 19
FUEL SOL (DIESEL)	D 10
FUEL TANK UNIT	A 20
FUS LINKS	B 2-3
FUSE BLOCK	B-C 13-14
GLOW PLUG CONTROLLER (DIESEL)	D 11
GLOW PLUGS (DIESEL)	E 11
HAZARD FLASHER	B 19
HEATER & A/C CONTROL	D-E 24
HORN RLY	C 23
HOT FUEL MOD (GAS)	C 4
IGNITION COIL (GAS)	D 7
IGNITION SW	A 12-15
ILLUM LT	C 19
IN-LINE FUSE (DIESEL)	B 10
INSTRUMENT CLUSTER	A-C 23
KICKDOWN RLY (GAS)	C 7
LEFT DOOR SW	E 20
LEFT PAIR WOODRUM SW	A 24-25
LO BLOWER RLY	D 24
LOW COOLANT MODULE (DIESEL)	B 20
LT DRIVER MODULE (DIESEL)	D 8
LT SW	A 18
OIL PRES SW (DIESEL)	B 11
SPEED SENSOR	E 19
STOP LT SW	B 19
TCC SOL (DIESEL)	C 9
TRANSFER CASE RLY	D 19
WATER IN FUEL SENS (DIESEL)	E 8
WIPER MOTOR	D 16
WIPER/WASHER SW	E 16

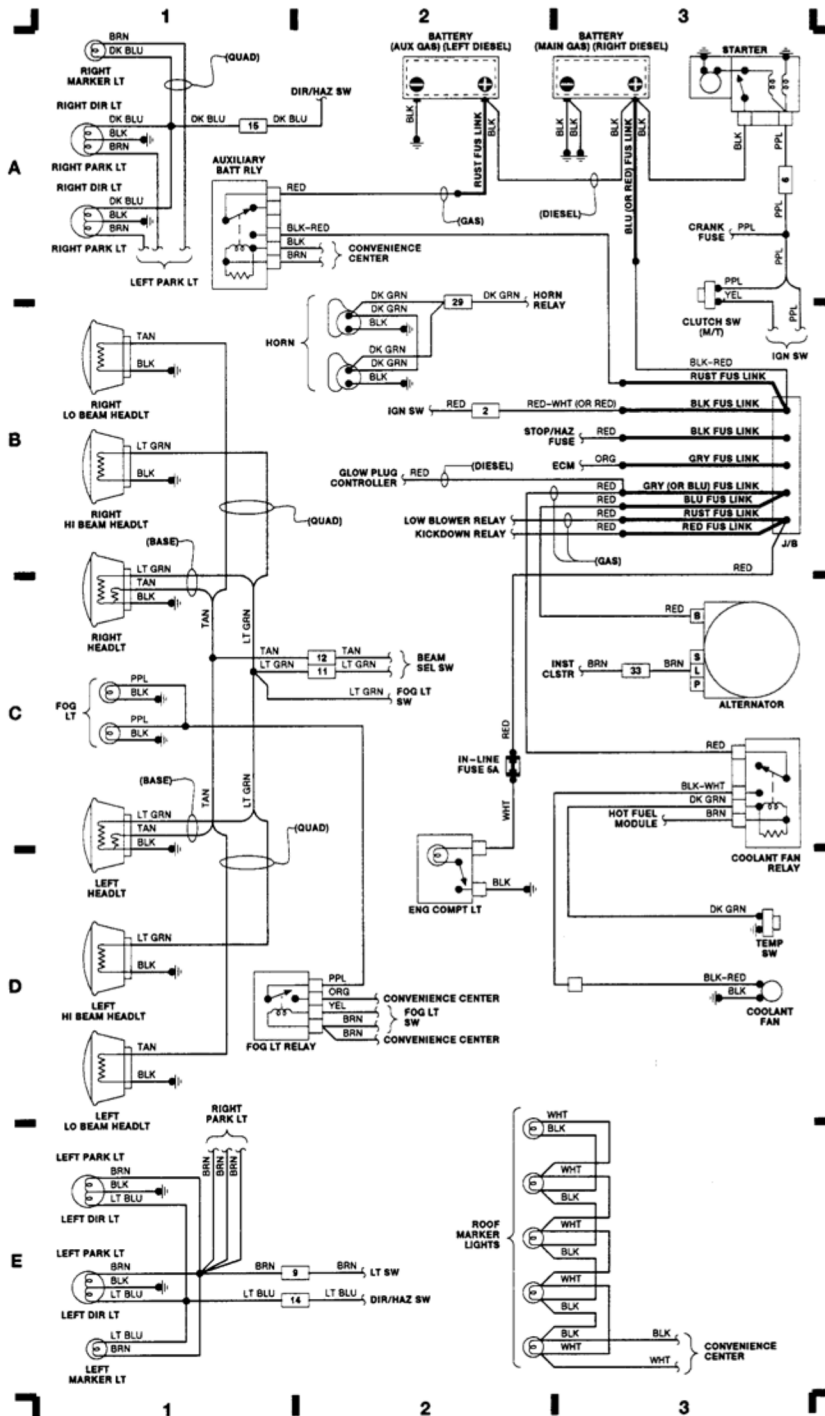

90D03731

Fig. 1: Engine Compartment & Headlights

1990 Chevrolet Pickup K1500

WIRING DIAGRAMS 1990 Wiring Diagrams General Motors Corp.

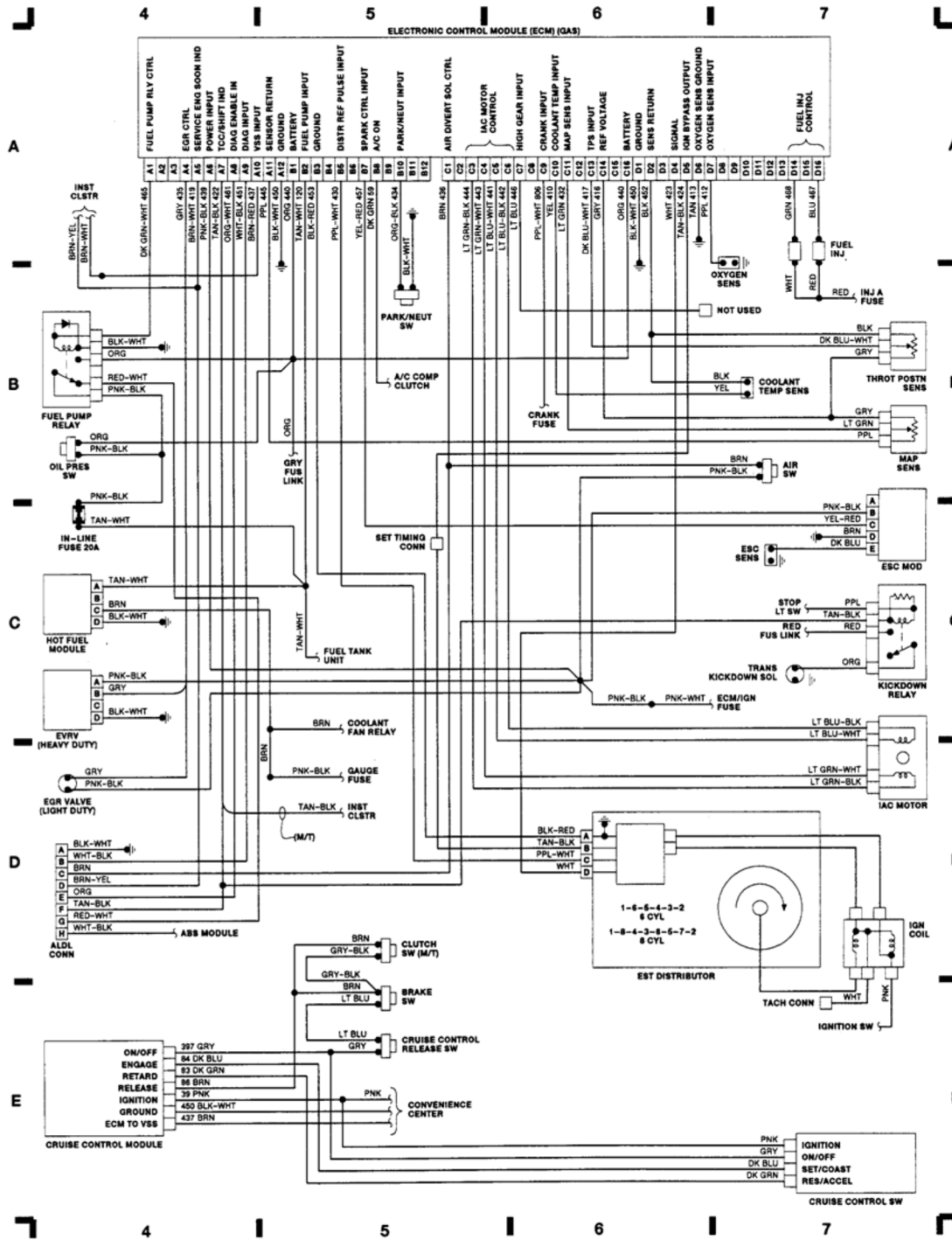
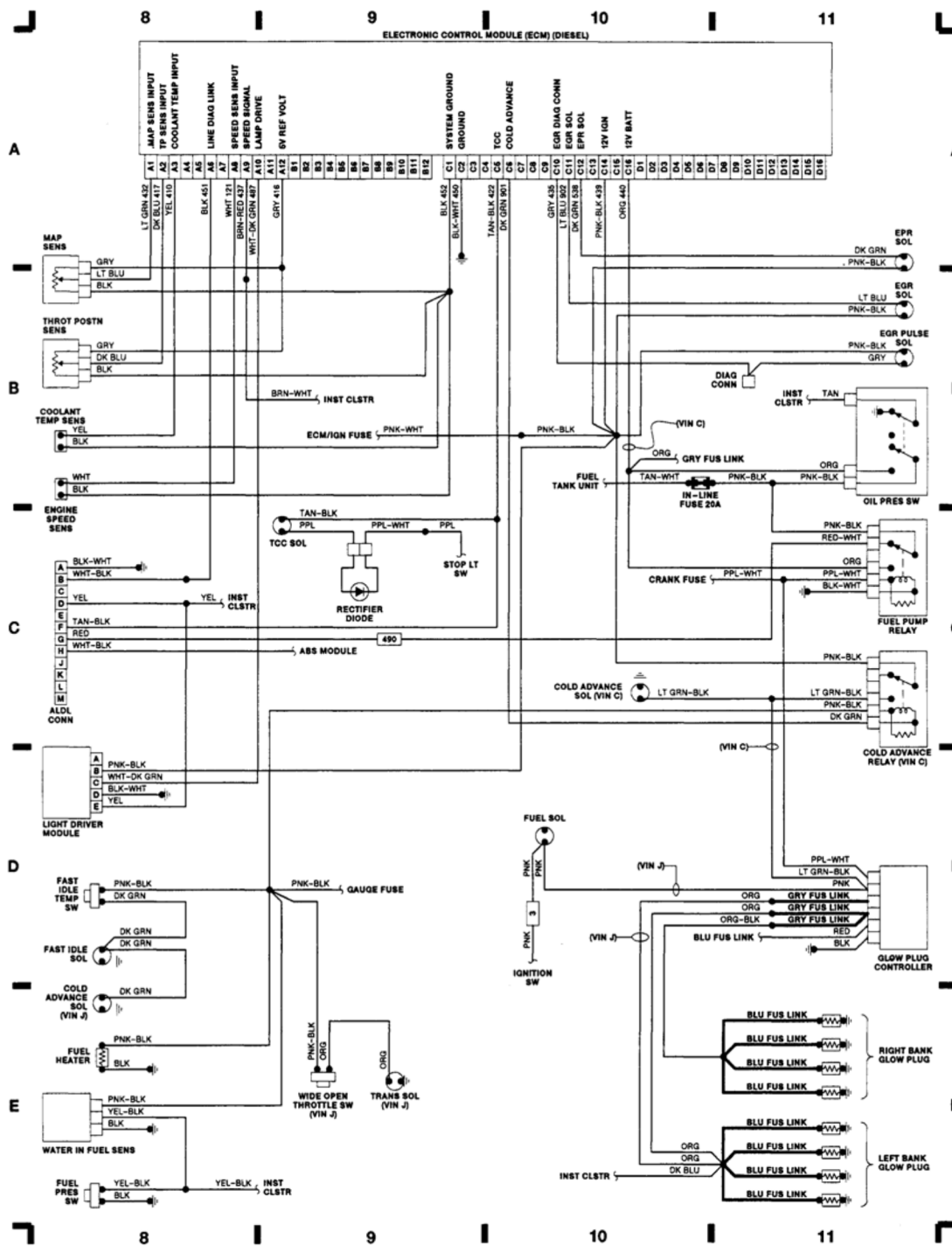

Fig. 2: Electronic Control Module (ECM) (Gas) & Cruise Control

1990 Chevrolet Pickup K1500

WIRING DIAGRAMS 1990 Wiring Diagrams General Motors Corp.



90H03733

Fig. 3: Electronic Control Module (ECM) (Diesel)

1990 Chevrolet Pickup K1500

WIRING DIAGRAMS 1990 Wiring Diagrams General Motors Corp.

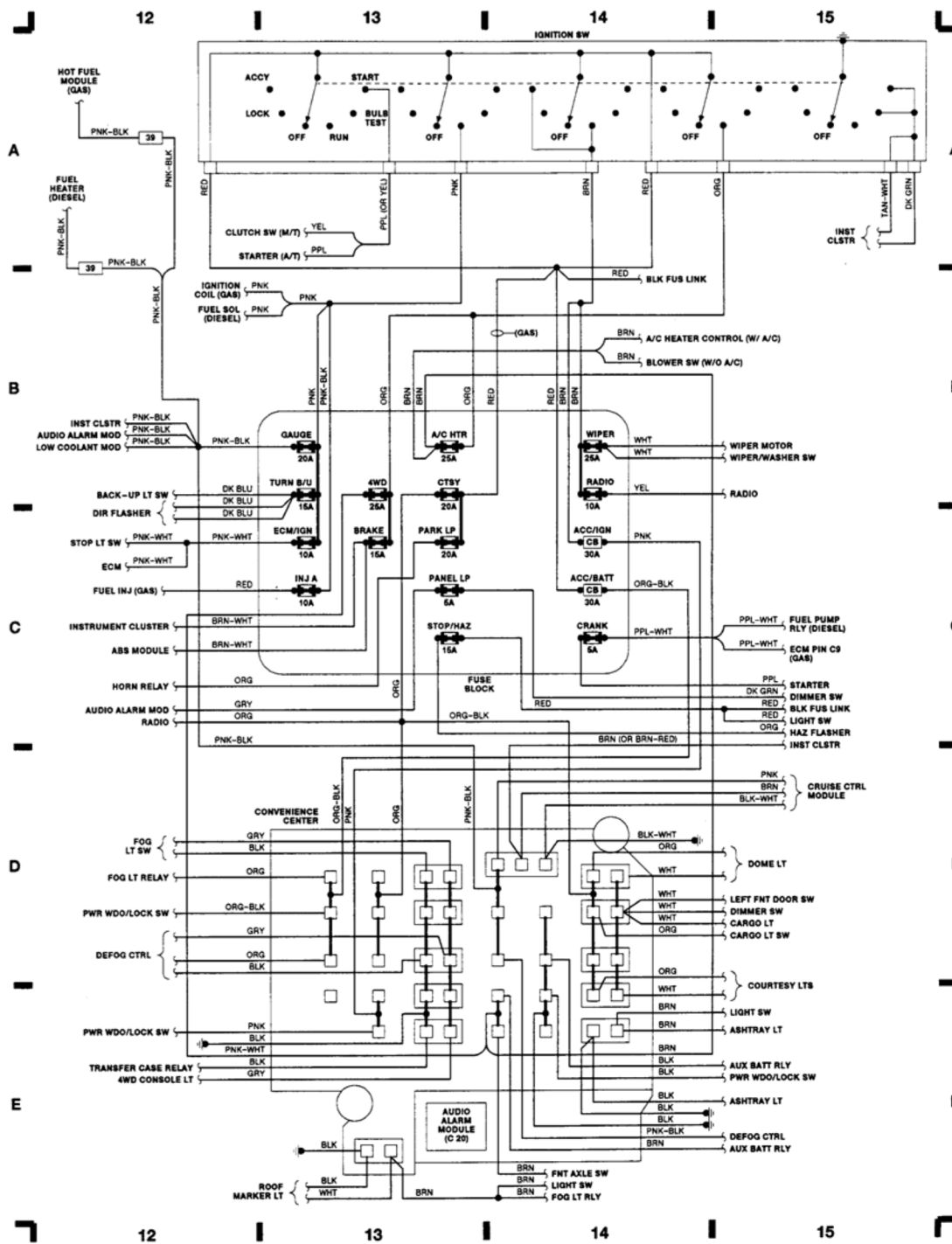

90J03734

Fig. 4: Fuse Block

1990 Chevrolet Pickup K1500

WIRING DIAGRAMS 1990 Wiring Diagrams General Motors Corp.

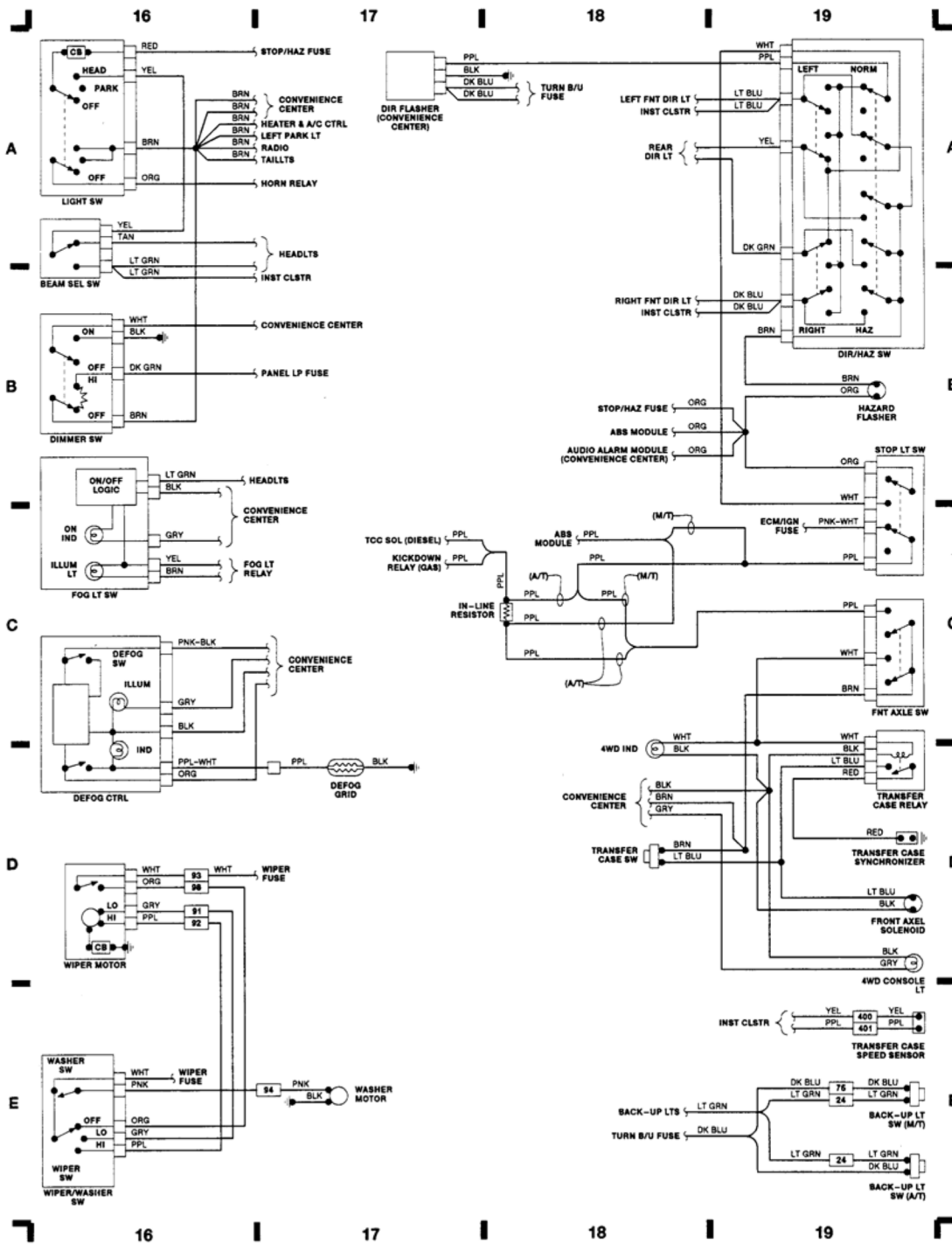

90C03735

Fig. 5: Wiper/Washer & Convenience Center

1990 Chevrolet Pickup K1500

WIRING DIAGRAMS 1990 Wiring Diagrams General Motors Corp.

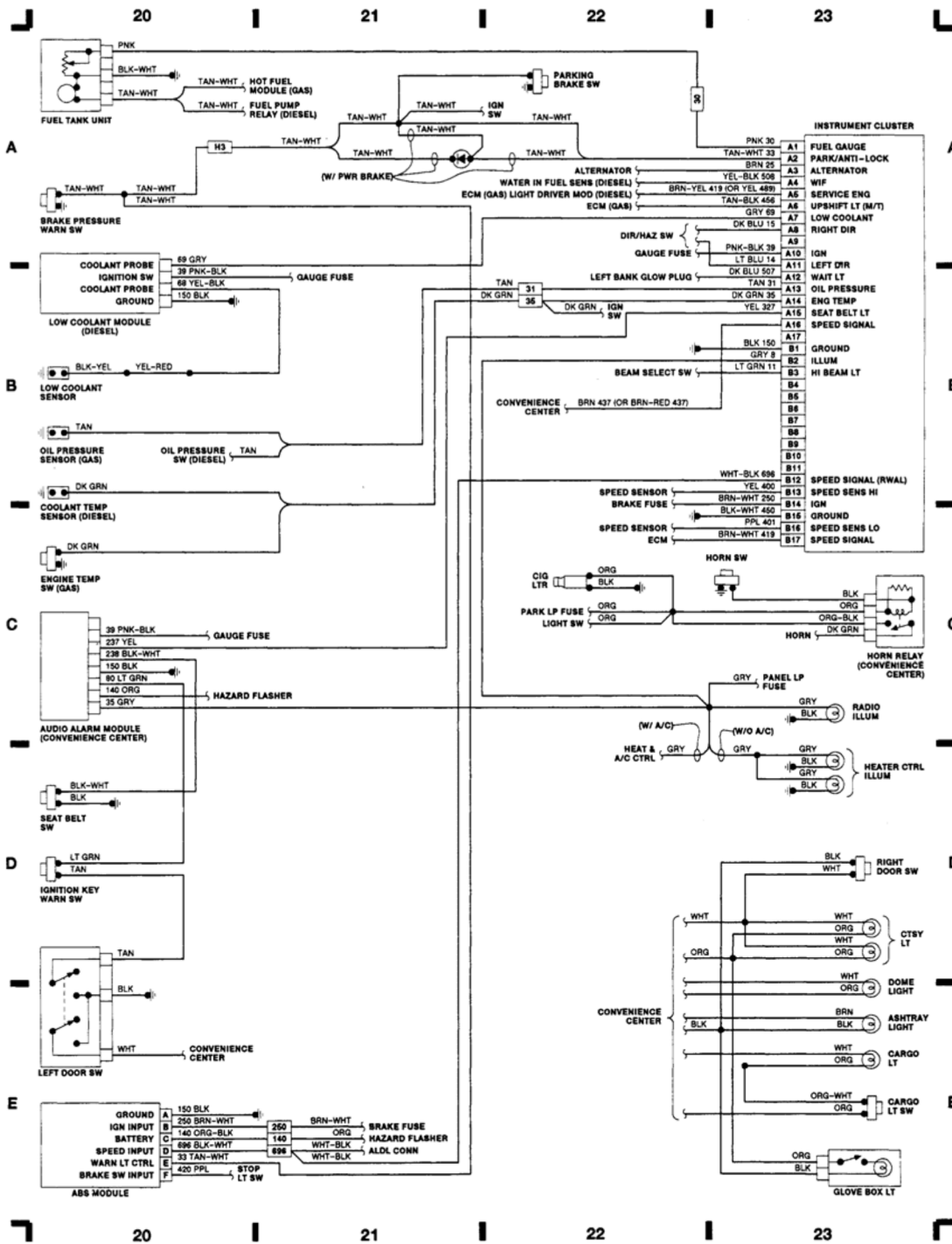

90E03736

Fig. 6: Instrument Cluster

1990 Chevrolet Pickup K1500

WIRING DIAGRAMS 1990 Wiring Diagrams General Motors Corp.

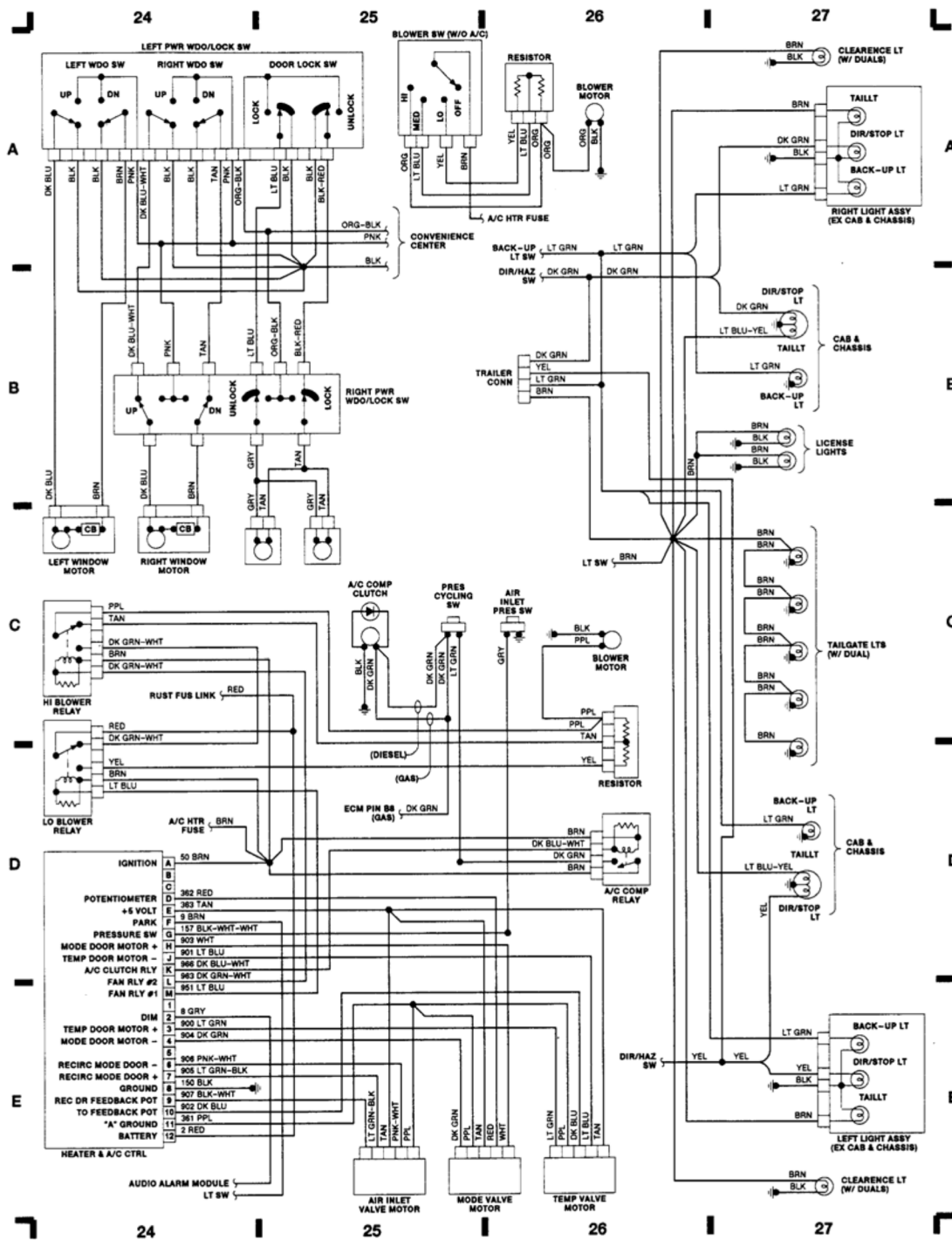

90G03737

Fig. 7: A/C-Heating, Power Windows & Taillights