

**Kawasaki**

**Ninja ZX-6R**



# **Motorcycle Service Manual**



# Quick Reference Guide

<b>General Information</b>	<b>1</b>
<b>Periodic Maintenance</b>	<b>2</b>
<b>Fuel System (DFI)</b>	<b>3</b>
<b>Cooling System</b>	<b>4</b>
<b>Engine Top End</b>	<b>5</b>
<b>Clutch</b>	<b>6</b>
<b>Engine Lubrication System</b>	<b>7</b>
<b>Engine Removal/Installation</b>	<b>8</b>
<b>Crankshaft/Transmission</b>	<b>9</b>
<b>Wheels/Tires</b>	<b>10</b>
<b>Final Drive</b>	<b>11</b>
<b>Brakes</b>	<b>12</b>
<b>Suspension</b>	<b>13</b>
<b>Steering</b>	<b>14</b>
<b>Frame</b>	<b>15</b>
<b>Electrical System</b>	<b>16</b>
<b>Appendix</b>	<b>17</b>

This quick reference guide will assist you in locating a desired topic or procedure.

- Bend the pages back to match the black tab of the desired chapter number with the black tab on the edge at each table of contents page.
- Refer to the sectional table of contents for the exact pages to locate the specific topic required.



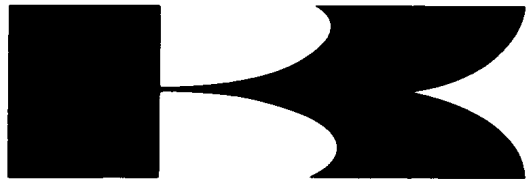

**Kawasaki**

**Ninja ZX-6R**

# **Motorcycle Service Manual**

---

All rights reserved. No parts of this publication may be reproduced, stored in a retrieval system, or transmitted in any form or by any means, electronic mechanical photocopying, recording or otherwise, without the prior written permission of Quality Assurance Division/Consumer Products & Machinery Company/Kawasaki Heavy Industries, Ltd., Japan.

No liability can be accepted for any inaccuracies or omissions in this publication, although every possible care has been taken to make it as complete and accurate as possible.

The right is reserved to make changes at any time without prior notice and without incurring an obligation to make such changes to products manufactured previously. See your Motorcycle dealer for the latest information on product improvements incorporated after this publication.

All information contained in this publication is based on the latest product information available at the time of publication. Illustrations and photographs in this publication are intended for reference use only and may not depict actual model component parts.

## LIST OF ABBREVIATIONS

A	ampere(s)	lb	pound(s)
ABDC	after bottom dead center	m	meter(s)
AC	alternating current	min	minute(s)
ATDC	after top dead center	N	newton(s)
BBDC	before bottom dead center	Pa	pascal(s)
BDC	bottom dead center	PS	horsepower
BTDC	before top dead center	psi	pound(s) per square inch
°C	degree(s) Celsius	r	revolution
DC	direct current	rpm	revolution(s) per minute
F	farad(s)	TDC	top dead center
°F	degree(s) Fahrenheit	TIR	total indicator reading
ft	foot, feet	V	volt(s)
g	gram(s)	W	watt(s)
h	hour(s)	Ω	ohm(s)
L	liter(s)		

## COUNTRY AND AREA CODES

AU	Australia	WVTA	Whole Vehicle Type Approval
CA	Canada	WVTA (FULL H)	WVTA Model with Honeycomb Catalytic Converter (Full Power)
CAL	California	GB WVTA (FULL H)	WVTA Model with Honeycomb Catalytic Converter (Left Side Traffic Full Power)
EUR	Europe	WVTA (78.2 H):	WVTA Model with Honeycomb Catalytic Converter (78.2 Kw Power)
MY	Malaysia		
US	United States		

## EMISSION CONTROL INFORMATION

To protect the environment in which we all live, Kawasaki has incorporated crankcase emission (1) and exhaust emission (2) control systems in compliance with applicable regulations of the United States Environmental Protection Agency and California Air Resources Board. Additionally, Kawasaki has incorporated an evaporative emission control system (3) in compliance with applicable regulations of the California Air Resources Board on vehicles sold in California only.

### 1. Crankcase Emission Control System

This system eliminates the release of crankcase vapors into the atmosphere. Instead, the vapors are routed through an oil separator to the inlet side of the engine. While the engine is operating, the vapors are drawn into combustion chamber, where they are burned along with the fuel and air supplied by the fuel injection system.

### 2. Exhaust Emission Control System

This system reduces the amount of pollutants discharged into the atmosphere by the exhaust of this motorcycle. The fuel, ignition, and exhaust systems of this motorcycle have been carefully designed and constructed to ensure an efficient engine with low exhaust pollutant levels.

The exhaust system of this model motorcycle manufactured primarily for sale in California includes a catalytic converter system.

### 3. Evaporative Emission Control System

Vapors caused by fuel evaporation in the fuel system are not vented into the atmosphere. Instead, fuel vapors are routed into the running engine to be burned, or stored in a canister when the engine is stopped. Liquid fuel is caught by a vapor separator and returned to the fuel tank.

The Clean Air Act, which is the Federal law covering motor vehicle pollution, contains what is commonly referred to as the Act's "tampering provisions".

"Sec. 203(a) The following acts and the causing thereof are prohibited...

(3)(A) for any person to remove or render inoperative any device or element of design installed on or in a motor vehicle or motor vehicle engine in compliance with regulations under this title prior to its sale and delivery to the ultimate purchaser, or for any manufacturer or dealer knowingly to remove or render inoperative any such device or element of design after such sale and delivery to the ultimate purchaser.

(3)(B) for any person engaged in the business of repairing, servicing, selling, leasing, or trading motor vehicles or motor vehicle engines, or who operates a fleet of motor vehicles knowingly to remove or render inoperative any device or element of design installed on or in a motor vehicle or motor vehicle engine in compliance with regulations under this title following its sale and delivery to the ultimate purchaser..."

### NOTE

○ *The phrase "remove or render inoperative any device or element of design" has been generally interpreted as follows.*

1. *Tampering does not include the temporary removal or rendering inoperative of devices or elements of design in order to perform maintenance.*
2. *Tampering could include.*
  - a. *Maladjustment of vehicle components such that the emission standards are exceeded.*
  - b. *Use of replacement parts or accessories which adversely affect the performance or durability of the motorcycle.*
  - c. *Addition of components or accessories that result in the vehicle exceeding the standards.*
  - d. *Permanently removing, disconnecting, or rendering inoperative any component or element of design of the emission control systems.*

**WE RECOMMEND THAT ALL DEALERS OBSERVE THESE PROVISIONS OF FEDERAL LAW, THE VIOLATION OF WHICH IS PUNISHABLE BY CIVIL PENALTIES NOT EXCEEDING \$10 000 PER VIOLATION.**

## **TAMPERING WITH NOISE CONTROL SYSTEM PROHIBITED**

Federal law prohibits the following acts or the causing thereof. (1) The removal or rendering inoperative by any person other than for purposes of maintenance, repair, or replacement, of any device or element of design incorporated into any new vehicle for the purpose of noise control prior to its sale or delivery to the ultimate purchaser or while it is in use, or (2) the use of the vehicle after such device or element of design has been removed or rendered inoperative by any person.

Among those acts presumed to constitute tampering are the acts listed below.

- Replacement of the original exhaust system or muffler with a component not in compliance with Federal regulations.
- Removal of the muffler(s) or any internal portion of the muffler(s).
- Removal of the air box or air box cover.
- Modifications to the muffler(s) or air inlet system by cutting, drilling, or other means if such modifications result in increased noise levels.



# Foreword

This manual is designed primarily for use by trained mechanics in a properly equipped shop. However, it contains enough detail and basic information to make it useful to the owner who desires to perform his own basic maintenance and repair work. A basic knowledge of mechanics, the proper use of tools, and workshop procedures must be understood in order to carry out maintenance and repair satisfactorily. Whenever the owner has insufficient experience or doubts his ability to do the work, all adjustments, maintenance, and repair should be carried out only by qualified mechanics.

In order to perform the work efficiently and to avoid costly mistakes, read the text, thoroughly familiarize yourself with the procedures before starting work, and then do the work carefully in a clean area. Whenever special tools or equipment are specified, do not use makeshift tools or equipment. Precision measurements can only be made if the proper instruments are used, and the use of substitute tools may adversely affect safe operation.

**For the duration of the warranty period,** we recommend that all repairs and scheduled maintenance be performed in accordance with this service manual. Any owner maintenance or repair procedure not performed in accordance with this manual may void the warranty.

To get the longest life out of your vehicle.

- Follow the Periodic Maintenance Chart in the Service Manual.
- Be alert for problems and non-scheduled maintenance.
- Use proper tools and genuine Kawasaki Motorcycle parts. Special tools, gauges, and testers that are necessary when servicing Kawasaki motorcycles are introduced by the Service Manual. Genuine parts provided as spare parts are listed in the Parts Catalog.
- Follow the procedures in this manual carefully. Don't take shortcuts.
- Remember to keep complete records of maintenance and repair with dates and any new parts installed.

---

## How to Use This Manual

---

In this manual, the product is divided into its major systems and these systems make up the manual's chapters. The Quick Reference

Guide shows you all of the product's system and assists in locating their chapters. Each chapter in turn has its own comprehensive Table of Contents.

For example, if you want stick coil information, use the Quick Reference Guide to locate the Electrical System chapter. Then, use the Table of Contents on the first page of the chapter to find the Stick Coil section.

Whenever you see these WARNING and CAUTION symbols, heed their instructions! Always follow safe operating and maintenance practices.

### WARNING

**This warning symbol identifies special instructions or procedures which, if not correctly followed, could result in personal injury, or loss of life.**

### CAUTION

**This caution symbol identifies special instructions or procedures which, if not strictly observed, could result in damage to or destruction of equipment.**

This manual contains four more symbols (in addition to WARNING and CAUTION) which will help you distinguish different types of information.

### NOTE

○ *This note symbol indicates points of particular interest for more efficient and convenient operation.*

- Indicates a procedural step or work to be done.
- Indicates a procedural sub-step or how to do the work of the procedural step it follows. It also precedes the text of a NOTE.
- ★ Indicates a conditional step or what action to take based on the results of the test or inspection in the procedural step or sub-step it follows.

In most chapters an exploded view illustration of the system components follows the Table of Contents. In these illustrations you will find the instructions indicating which parts require specified tightening torque, oil, grease or a locking agent during assembly.



# General Information

## Table of Contents

Before Servicing .....	1-2
Model Identification.....	1-7
General Specifications.....	1-9
Unit Conversion Table .....	1-12

## 1-2 GENERAL INFORMATION

### Before Servicing

Before starting to perform an inspection service or carry out a disassembly and reassembly operation on a motorcycle, read the precautions given below. To facilitate actual operations, notes, illustrations, photographs, cautions, and detailed descriptions have been included in each chapter wherever necessary. This section explains the items that require particular attention during the removal and reinstallation or disassembly and reassembly of general parts.

Especially note the following.

#### **Battery Ground**

Before completing any service on the motorcycle, disconnect the battery cables from the battery to prevent the engine from accidentally turning over. Disconnect the ground cable (–) first and then the positive (+). When completed with the service, first connect the positive (+) cable to the positive (+) terminal of the battery then the negative (–) cable to the negative terminal.

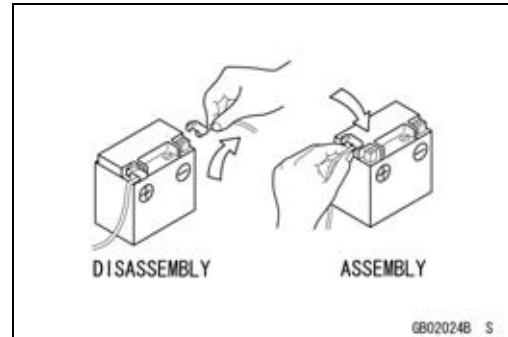

#### **Edges of Parts**

Lift large or heavy parts wearing gloves to prevent injury from possible sharp edges on the parts.

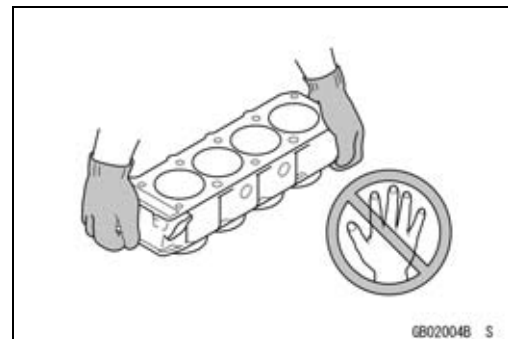

#### **Solvent**

Use a high-flash point solvent when cleaning parts. High-flash point solvent should be used according to directions of the solvent manufacturer.

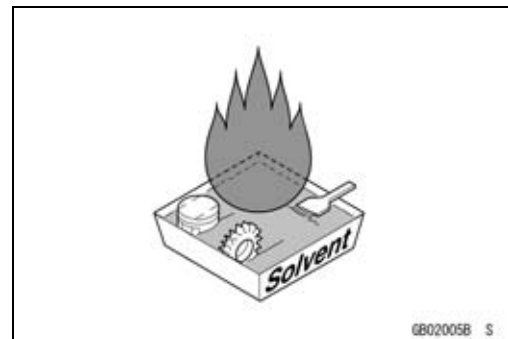

#### **Cleaning vehicle before disassembly**

Clean the vehicle thoroughly before disassembly. Dirt or other foreign materials entering into sealed areas during vehicle disassembly can cause excessive wear and decrease performance of the vehicle.

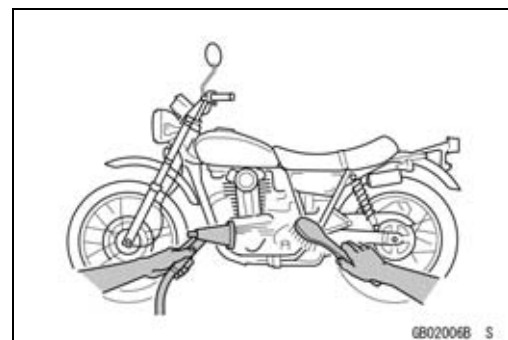

**Before Servicing**

**Arrangement and Cleaning of Removed Parts**

Disassembled parts are easy to confuse. Arrange the parts according to the order the parts were disassembled and clean the parts in order prior to assembly.

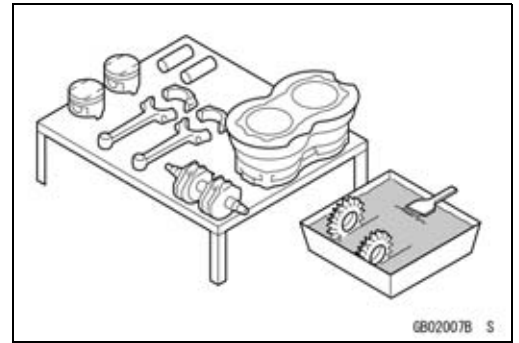

**Storage of Removed Parts**

After all the parts including subassembly parts have been cleaned, store the parts in a clean area. Put a clean cloth or plastic sheet over the parts to protect from any foreign materials that may collect before re-assembly.

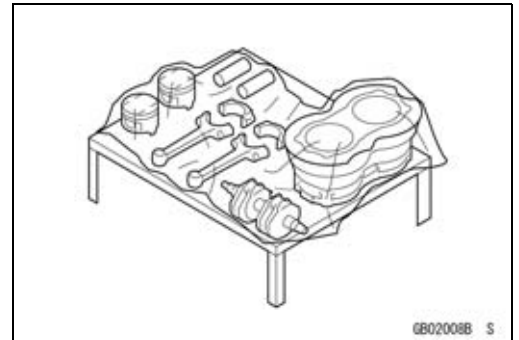

**Inspection**

Reuse of worn or damaged parts may lead to serious accident. Visually inspect removed parts for corrosion, discoloration, or other damage. Refer to the appropriate sections of this manual for service limits on individual parts. Replace the parts if any damage has been found or if the part is beyond its service limit.

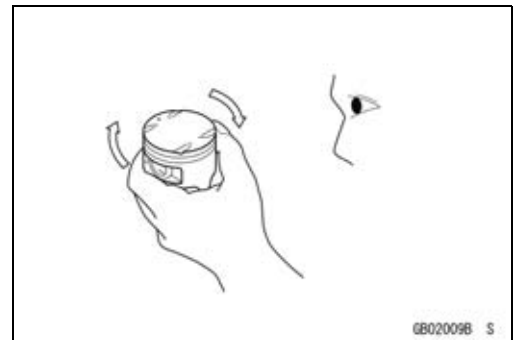

**Replacement Parts**

Replacement Parts must be KAWASAKI genuine or recommended by KAWASAKI. Gaskets, O-rings, oil seals, grease seals, circlips or cotter pins must be replaced with new ones whenever disassembled.

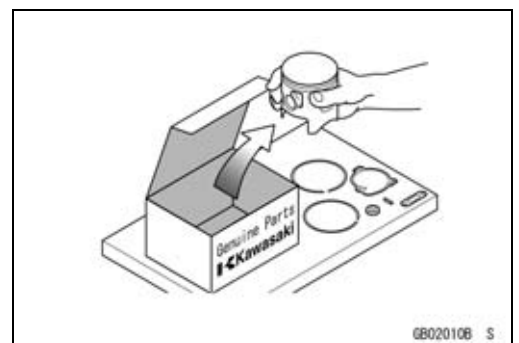

**Assembly Order**

In most cases assembly order is the reverse of disassembly, however, if assembly order is provided in this Service Manual, follow the procedures given.

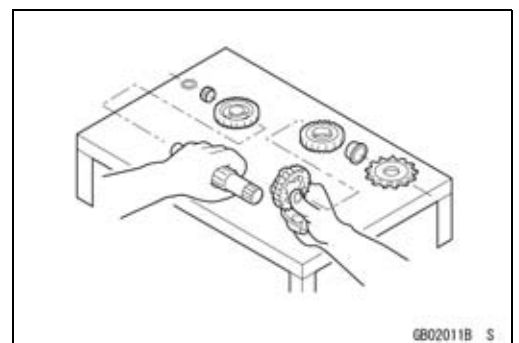

# 1-4 GENERAL INFORMATION

## Before Servicing

### **Tightening Sequence**

Generally, when installing a part with several bolts, nuts, or screws, start them all in their holes and tighten them to a snug fit. Then tighten them according to the specified sequence to prevent case warpage or deformation which can lead to malfunction. Conversely when loosening the bolts, nuts, or screws, first loosen all of them by about a quarter turn and then remove them. If the specified tightening sequence is not indicated, tighten the fasteners alternating diagonally.

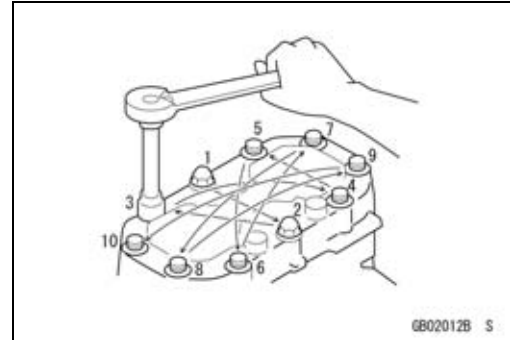

### **Tightening Torque**

Incorrect torque applied to a bolt, nut, or screw may lead to serious damage. Tighten fasteners to the specified torque using a good quality torque wrench.

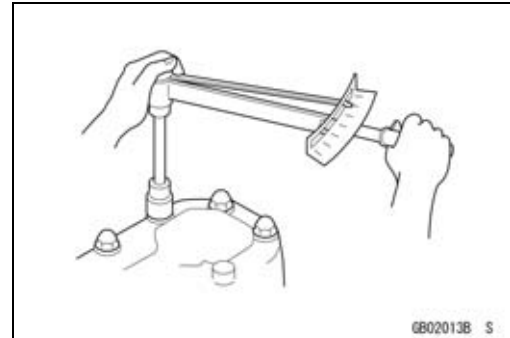

### **Force**

Use common sense during disassembly and assembly, excessive force can cause expensive or hard to repair damage. When necessary, remove screws that have a non-permanent locking agent applied using an impact driver. Use a plastic-faced mallet whenever tapping is necessary.

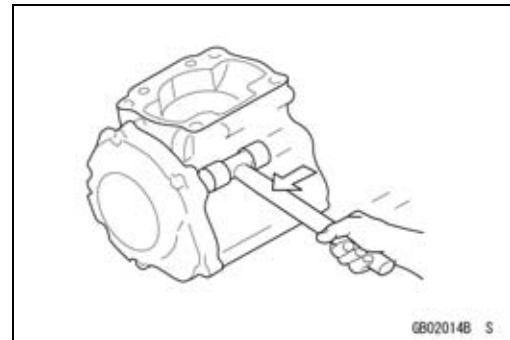

### **Gasket, O-ring**

Hardening, shrinkage, or damage of both gaskets and O-rings after disassembly can reduce sealing performance. Remove the old gaskets and clean the sealing surfaces thoroughly so that no gasket material or other material remains. Install the new gaskets and replace the used O-rings when re-assembling.

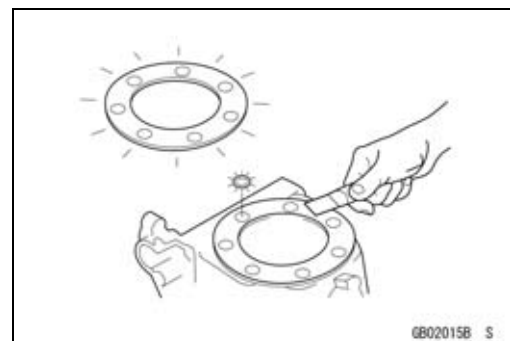

### **Liquid Gasket, Non-permanent Locking Agent**

For applications that require Liquid Gasket or a Non-Permanent Locking Agent, clean the surfaces so that no oil residue remains before applying liquid gasket or non-permanent locking agent. Do not apply them excessively. Excessive application can clog oil passages and cause serious damage.



**Before Servicing**

**Press**

For items such as bearings or oil seals that must be pressed into place, apply small amount of oil to the contact area. Be sure to maintain proper alignment and use smooth movements when installing.

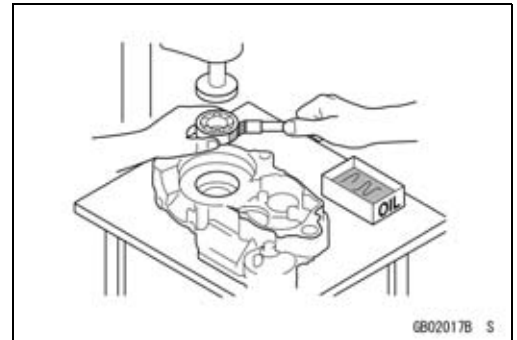

**Ball Bearing and Needle Bearing**

Do not remove pressed ball or needle unless removal is absolutely necessary. Replace with new ones whenever removed. Press bearings with the manufacturer and size marks facing out. Press the bearing into place by putting pressure on the correct bearing race as shown.

Pressing the incorrect race can cause pressure between the inner and outer race and result in bearing damage.

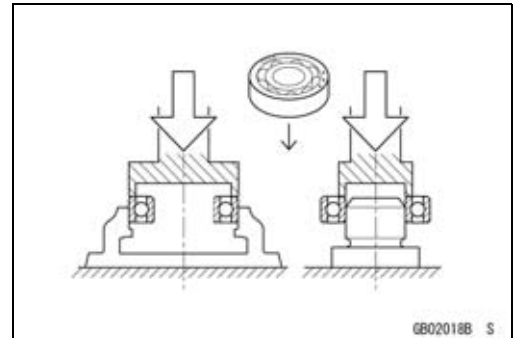

**Oil Seal, Grease Seal**

Do not remove pressed oil or grease seals unless removal is necessary. Replace with new ones whenever removed. Press new oil seals with manufacture and size marks facing out. Make sure the seal is aligned properly when installing.

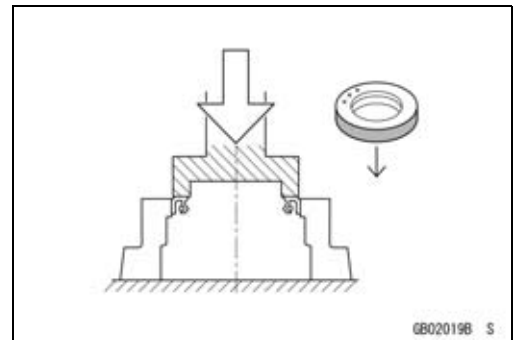

Apply specified grease to the lip of seal before installing the seal.

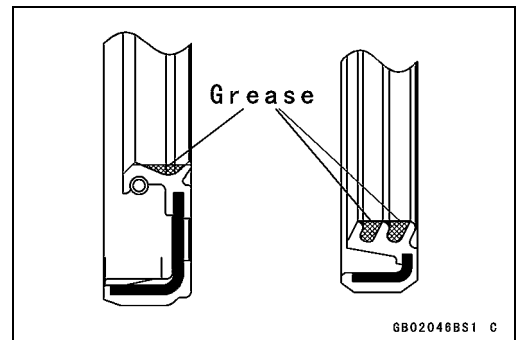

**Circlips, Cotter Pins**

Replace the circlips or cotter pins that were removed with new ones. Take care not to open the clip excessively when installing to prevent deformation.

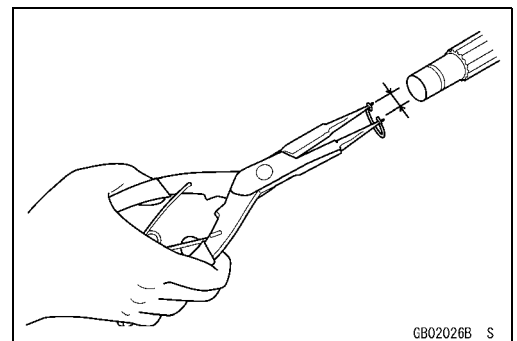

## 1-6 GENERAL INFORMATION

### Before Servicing

#### **Lubrication**

It is important to lubricate rotating or sliding parts during assembly to minimize wear during initial operation. Lubrication points are called out throughout this manual, apply the specific oil or grease as specified.

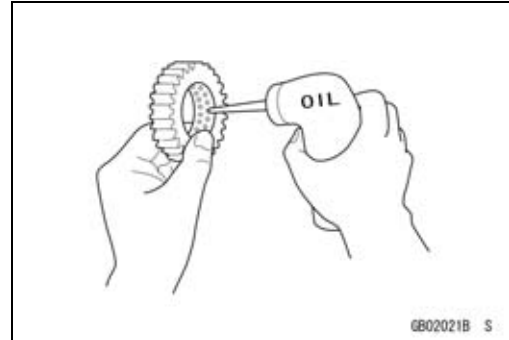

#### **Direction of Engine Rotation**

When rotating the crankshaft by hand, the free play amount of rotating direction will affect the adjustment. Rotate the crankshaft to positive direction (clockwise viewed from output side).

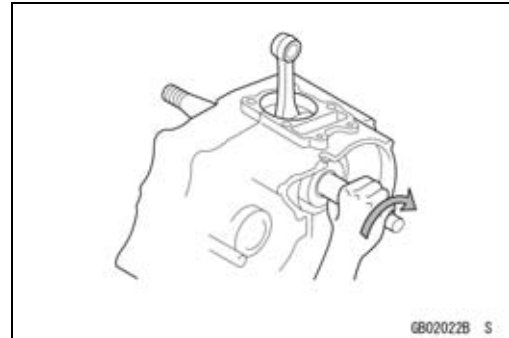

#### **Electrical Wires**

A two-color wire is identified first by the primary color and then the stripe color. Unless instructed otherwise, electrical wires must be connected to those of the same color.

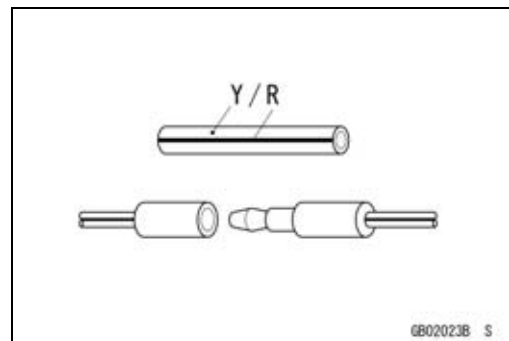

#### **Instrument**

Use a meter that has enough accuracy for an accurate measurement. Read the manufacturer's instructions thoroughly before using the meter. Incorrect values may lead to improper adjustments.

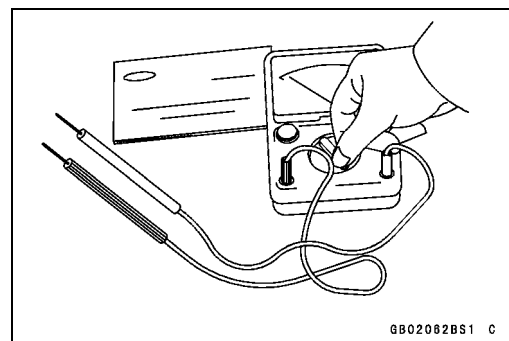



Model Identification

ZX600P7F (Europe) Left Side View



ZX600P7F (Europe) Right Side View



Frame Number

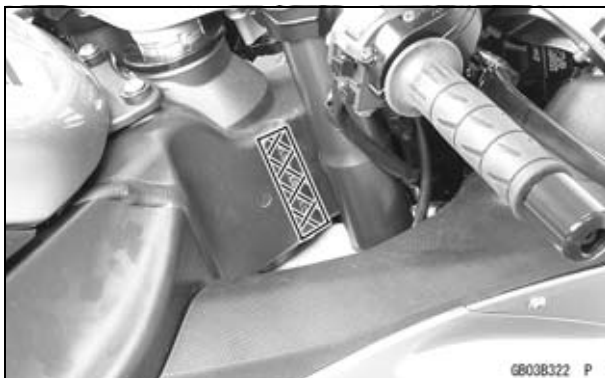

Engine Number



## 1-8 GENERAL INFORMATION

### Model Identification

ZX600P7F (US and Canada) Left Side View



6803B294 P

ZX600P7F (US and Canada) Right Side View



6803B295 P

General Specifications

Items	ZX600P7F ~
<b>Dimensions</b>	
Overall Length	2 105 mm (82.9 in.)
Overall Width	720 mm (28.3 in.)
Overall Height	1 125 mm (44.3 in.)
Wheelbase	1 405 mm (55.3 in.)
Road Clearance	125 mm (4.7 in.)
Seat Height	820 mm (32.3 in.)
Dry Mass	167 kg (368 lb)
Curb Mass:	
Front	101 kg (223 lb)
Rear	99 kg (218 lb)
Fuel Tank Capacity	17 L (4.5 US gal)
<b>Performance</b>	
Minimum Turning Radius	3.4 m (11.2 ft)
<b>Engine</b>	
Type	4-stroke, DOHC, 4-cylinder
Cooling System	Liquid-cooled
Bore and Stroke	67.0 × 42.5 mm (2.6 × 1.7 in.)
Displacement	599 mL (36.6 cu in.)
Compression Ratio	13.3 : 1
Maximum Horsepower	91.9 kW (125 PS) @14 000 r/min (rpm), WVTA (78.2 H) 78.2 kW (106 PS) @14 000 r/min (rpm), (MY) 80.0 kW (109 PS) @12 000 r/min (rpm), (CA), (CAL), (US) – – –
Maximum Torque	66.0 N·m (6.7 kgf·m, 49 ft·lb) @11 700 r/min (rpm), WVTA (78.2 H) 58.4 N·m (6.0 kgf·m, 43 ft·lb) @11 700 r/min (rpm), (MY) 64 N·m (6.5 kgf·m, 47 ft·lb) @12 000 r/min (rpm) (CA), (CAL), (US) – – –
Carburetion System	FI (Fuel injection) Primary: KEIHIN TTK 38 × 4 Secondary: KEIHIN Multihole (8 holes) × 4
Starting System	Electric starter
Ignition System	Battery and coil (transistorized)
Timing Advance	Electronically advanced (digital igniter in ECU)
Ignition Timing	From 12.5° BTDC @1 300 r/min (rpm)
Spark Plug	NGK CR9E
Cylinder Numbering Method	Left to right, 1-2-3-4
Firing Order	1-2-4-3
Valve Timing:	
Inlet:	
Open	41° BTDC
Close	67° ABDC
Duration	288°
Exhaust:	
Open	63° BBDC
Close	23° ATDC

# 1-10 GENERAL INFORMATION

## General Specifications

Items	ZX600P7F ~
Duration Lubrication System Engine Oil: Type Viscosity Capacity	266° Forced lubrication (wet sump with cooler)  API SE, SF or SG API SH, SJ or SL with JASO MA  SAE10W-40 3.8 L (4.0 US qt)
<b>Drive Train</b> Primary Reduction System: Type Reduction Ratio Clutch Type Transmission: Type Gear Ratios: 1st 2nd 3rd 4th 5th 6th Final Drive System: Type Reduction Ratio Overall Drive Ratio	Gear 1.900 (76/40) Wet multi disc 6-speed, constant mesh, return shift  2.714 (38/14) 2.200 (33/15) 1.850 (37/20) 1.600 (32/20) 1.421 (27/19) 1.300 (26/20)  Chain drive 2.688 (43/16) 6.638 @Top gear
<b>Frame</b> Type Caster (Rake Angle) Trail Front Tire: Type Size Rear Tire: Type Size Rim Size: Front Rear Front Suspension: Type Wheel Travel Rear Suspension: Type Wheel Travel	Tubular, diamond 25° 110 mm (4.3 in.)  Tubeless 120/70 ZR17 M/C (58 W)  Tubeless 180/55 ZR17 M/C (73 W)  17 × 3.50 17 × 5.50  Telescopic fork (upside-down) 120 mm (4.7 in.)  Swingarm (uni-trak) 133 mm (5.2 in.)

---

**General Specifications**

---

Items	ZX600P7F ~
Brake Type: Front Rear	Dual discs Single disc
<b>Electrical Equipment</b> Battery Headlight: Type Bulb: High Low Tail/Brake Light Alternator: Type Rated Output	12 V 8 Ah Semi-sealed beam 12 V 55 W + 65 W (quartz-halogen) 12 V 55 W (quartz-halogen) 12 V 0.1/1.6 W (LED) Three-phase AC 31 A/14 V @5 000 r/min (rpm)

Specifications subject to change without notice, and may not apply to every country.

# 1-12 GENERAL INFORMATION

## Unit Conversion Table

### Prefixes for Units

Prefix	Symbol	Power
mega	M	× 1 000 000
kilo	k	× 1 000
centi	c	× 0.01
milli	m	× 0.001
micro	μ	× 0.000001

### Units of Mass

kg	×	2.205	=	lb
g	×	0.03527	=	oz

### Units of Volume

L	×	0.2642	=	gal (US)
L	×	0.2200	=	gal (imp)
L	×	1.057	=	qt (US)
L	×	0.8799	=	qt (imp)
L	×	2.113	=	pint (US)
L	×	1.816	=	pint (imp)
mL	×	0.03381	=	oz (US)
mL	×	0.02816	=	oz (imp)
mL	×	0.06102	=	cu in

### Units of Force

N	×	0.1020	=	kg
N	×	0.2248	=	lb
kg	×	9.807	=	N
kg	×	2.205	=	lb

### Units of Length

km	×	0.6214	=	mile
m	×	3.281	=	ft
mm	×	0.03937	=	in

### Units of Torque

N·m	×	0.1020	=	kgf·m
N·m	×	0.7376	=	ft·lb
N·m	×	8.851	=	in·lb
kgf·m	×	9.807	=	N·m
kgf·m	×	7.233	=	ft·lb
kgf·m	×	86.80	=	in·lb

### Units of Pressure

kPa	×	0.01020	=	kgf/cm <sup>2</sup>
kPa	×	0.1450	=	psi
kPa	×	0.7501	=	cmHg
kgf/cm <sup>2</sup>	×	98.07	=	kPa
kgf/cm <sup>2</sup>	×	14.22	=	psi
cmHg	×	1.333	=	kPa

### Units of Speed

km/h	×	0.6214	=	mph
------	---	--------	---	-----

### Units of Power

kW	×	1.360	=	PS
kW	×	1.341	=	HP
PS	×	0.7355	=	kW
PS	×	0.9863	=	HP

### Units of Temperature

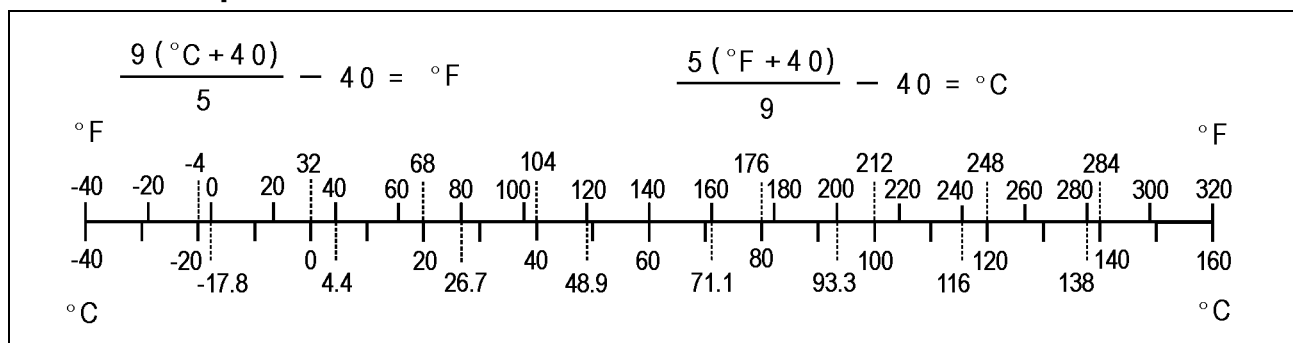

# Periodic Maintenance

## Table of Contents

Periodic Maintenance Chart .....	2-3
Torque and Locking Agent.....	2-6
Specifications .....	2-12
Special Tools .....	2-14
Maintenance Procedure .....	2-15
Fuel System (DFI).....	2-15
Throttle Control System Inspection.....	2-15
Engine Vacuum Synchronization Inspection.....	2-15
Idle Speed Inspection .....	2-18
Idle Speed Adjustment.....	2-19
Fuel Hose Inspection (fuel leak, damage, installation condition) .....	2-19
Evaporative Emission Control System Inspection (California Model) .....	2-19
Engine Top End .....	2-20
Valve Clearance Inspection .....	2-20
Valve Clearance Adjustment.....	2-22
Air Suction System Damage Inspection.....	2-24
Cooling System.....	2-25
Coolant Level Inspection.....	2-25
Radiator Hose Damage and Installation Condition Inspection.....	2-25
Clutch.....	2-26
Clutch Operation Inspection .....	2-26
Wheels/Tires .....	2-27
Air Pressure Inspection.....	2-27
Wheel/Tire Damage Inspection.....	2-27
Tire Tread Wear Inspection .....	2-27
Wheel Bearing Damage Inspection .....	2-28
Final Drive.....	2-29
Drive Chain Lubrication Condition Inspection .....	2-29
Drive Chain Slack Inspection .....	2-29
Drive Chain Slack Adjustment .....	2-30
Wheel Alignment Inspection .....	2-31
Drive Chain Wear Inspection .....	2-31
Chain Guide Wear Inspection .....	2-32
Brakes.....	2-32
Brake Fluid Leak (Brake Hose and Pipe) Inspection .....	2-32
Brake Hose Damage and Installation Condition Inspection.....	2-32
Brake Operation Inspection .....	2-33
Brake Fluid Level Inspection.....	2-33
Brake Pad Wear Inspection .....	2-34
Brake Light Switch Operation Inspection .....	2-34
Suspensions .....	2-35
Front Forks/Rear Shock Absorber Operation Inspection .....	2-35
Front Fork Oil Leak Inspection.....	2-35
Rear Shock Absorber Oil Leak Inspection .....	2-36
Rocker Arm Operation Inspection.....	2-36
Tie-Rod Operation Inspection .....	2-36
Steering System .....	2-36
Steering Play Inspection .....	2-36
Steering Play Adjustment.....	2-37
Steering Stem Bearing Lubrication .....	2-38

## 2-2 PERIODIC MAINTENANCE

---

Lights and Switches Operation Inspection.....	2-38
Headlight Aiming Inspection .....	2-40
Side Stand Switch Operation Inspection.....	2-41
Engine Stop Switch Operation Inspection.....	2-42
Others .....	2-43
Chassis Parts Lubrication .....	2-43
Bolts, Nuts and Fasteners Tightness Inspection.....	2-44
Replacement Parts .....	2-45
Air Cleaner Element Replacement.....	2-45
Fuel Hose Replacement .....	2-46
Coolant Change .....	2-49
Radiator Hose and O-ring Replacement.....	2-51
Engine Oil Change.....	2-52
Oil Filter Replacement .....	2-52
Brake Hose and Pipe Replacement.....	2-53
Brake Fluid Change .....	2-53
Master Cylinder Rubber Parts Replacement .....	2-55
Caliper Rubber Parts Replacement .....	2-56
Spark Plug Replacement .....	2-59



**Periodic Maintenance Chart**

The scheduled maintenance must be done in accordance with this chart to keep the motorcycle in good running condition. **The initial maintenance is vitally important and must not be neglected.**

**Periodic Inspection**

ITEM	FREQUENCY	* ODOMETER READING × 1 000 km (× 1 000 mile)							
		Whichever comes first ↓ Every	1 (0.6)	6 (4)	12 (7.5)	18 (12)	24 (15)	30 (20)	36 (24)
<b>Fuel System</b>									
Throttle control system (play, smooth return, no drag)-inspect	year	●		●		●		●	
Engine vacuum synchronization-inspect				●		●		●	
Idle speed-inspect		●		●		●		●	
Fuel leak (fuel hose and pipe)-inspect	year	●		●		●		●	
Fuel hose and pipe damage-inspect	year	●		●		●		●	
Fuel hose and pipe installation condition-inspect	year	●		●		●		●	
Evaporative emission control system function (California)-inspect		●	●	●	●	●	●	●	
<b>Cooling System</b>									
Coolant level-inspect		●		●		●		●	
Coolant leak (radiator hose and pipe)-inspect	year	●		●		●		●	
Radiator hose damage-inspect	year	●		●		●		●	
Radiator hose installation condition -inspect	year	●		●		●		●	
<b>Engine Top End</b>									
Valve clearance-inspect ( <b>United States and Canada Models</b> )						●			
Valve clearance-inspect ( <b>Other than United States and Canada Models</b> )		Every 42 000 km (26 000 mile)							
Air suction system damage-inspect				●		●		●	
<b>Clutch</b>									
Clutch operation (play, disengagement, engagement)-inspect		●		●		●		●	
<b>Wheels and Tires</b>									
Tire air pressure-inspect	year			●		●		●	
Wheel/tire damage-inspect				●		●		●	
Tire tread wear, abnormal wear-inspect				●		●		●	
Wheel bearing damage-inspect	year			●		●		●	
<b>Final Drive</b>									
Drive chain lubrication condition-inspect #		Every 600 km (400 mile)							
Drive chain slack-inspect #		Every 1 000 km (600 mile)							
Drive chain wear-inspect #				●		●		●	
Drive chain guide wear-inspect				●		●		●	

## 2-4 PERIODIC MAINTENANCE

### Periodic Maintenance Chart

ITEM	FREQUENCY	Whichever comes first ↓ Every	* ODOMETER READING × 1 000 km (× 1 000 mile)						
			1 (0.6)	6 (4)	12 (7.5)	18 (12)	24 (15)	30 (20)	36 (24)
<b>Brakes</b>									
Brake fluid leak (brake hose and pipe)-inspect	year	●	●	●	●	●	●	●	●
Brake hose and pipe damage-inspect	year	●	●	●	●	●	●	●	●
Brake pad wear-inspect #			●	●	●	●	●	●	●
Brake hose installation condition-inspect	year	●	●	●	●	●	●	●	●
Brake fluid level-inspect	6 months	●	●	●	●	●	●	●	●
Brake operation (effectiveness, play, no drag)-inspect	year	●	●	●	●	●	●	●	●
Brake light switch operation-inspect		●	●	●	●	●	●	●	●
<b>Suspension</b>									
Front forks/rear shock absorber operation (damping and smooth stroke)-inspect				●		●		●	
Front forks/rear shock absorber oil leak-inspect	year			●		●		●	
Rocker arm operation-inspect				●		●		●	
Tie-Rods operation-inspect				●		●		●	
<b>Steering</b>									
Steering play-inspect	year	●		●		●		●	
Steering stem bearings-lubricate	2 years					●			
<b>Electrical System</b>									
Lights and switches operation-inspect	year			●		●		●	
Headlight aiming-inspect	year			●		●		●	
Side stand switch operation-inspect	year			●		●		●	
Engine stop switch operation-inspect	year			●		●		●	
<b>Others</b>									
Chassis parts-lubricate	year			●		●		●	
Bolts and nuts tightness-inspect		●		●		●		●	

\*: For higher odometer readings, repeat at the frequency interval established here.

#: Service more frequently when operating in severe conditions; dusty, wet, muddy, high speed or frequent starting/stopping.

CAL: California Model

## PERIODIC MAINTENANCE 2-5

### Periodic Maintenance Chart

#### Periodic Replacement Parts

ITEM	FREQUENCY	* ODOMETER READING × 1 000 km (× 1 000 mile)				
		1 (0.6)	12 (7.5)	24 (15)	36 (24)	48 (30)
Air cleaner element - replace#	Whichever come first ↓ Every	→ Every 18 000 km (12 000 mile)				
Fuel hose - replace	4 years					●
Coolant - change	3 years				●	
Radiator hose and O-ring - replace	3 years				●	
Engine oil - change#	year	●	●	●	●	●
Oil filter - replace	year	●	●	●	●	●
Brake hose and pipe - replace	4 years					●
Brake fluid - change	2 years			●		●
Rubber parts of master cylinder and caliper - replace	4 years					●
Spark plug - replace			●	●	●	●

\*: For higher odometer readings, repeat at the frequency interval established here.

#: Service more frequently when operating in severe conditions; dusty, wet, muddy, high speed or frequent starting/stopping.

## 2-6 PERIODIC MAINTENANCE

### Torque and Locking Agent

The following tables list the tightening torque for the major fasteners requiring use of a non-permanent locking agent or silicone sealant etc.

Letters used in the "Remarks" column mean:

AL: Tighten the two clamp bolts alternately two times to ensure even tightening torque.

G: Apply grease to the threads.

L: Apply a non-permanent locking agent to the threads.

MO: Apply molybdenum disulfide oil solution.

R: Replacement Parts

S: Follow the specified tightening sequence.

SI: Apply silicone grease.

SS: Apply silicone sealant.

Fastener	Torque			Remarks
	N-m	kgf-m	ft-lb	
<b>Fuel System</b>				
Air Cleaner Housing Screws	1.1	0.11	9.7 in-lb	
Air Cleaner Housing Clamp Bolts	2.0	0.20	17 in-lb	
Air Cleaner Housing Mounting Bolt	6.9	0.70	61 in-lb	
Air Inlet Duct Mounting Bolts	9.8	1.0	87 in-lb	L
Camshaft Position Sensor Bolt	9.8	1.0	87 in-lb	
Crankshaft Sensor Bolts	5.9	0.60	52 in-lb	
Delivery Pipe Mounting Screws (Nozzle Assy)	3.4	0.35	30 in-lb	
Delivery Pipe Mounting Screws (Throttle Body)	3.4	0.35	30 in-lb	
Exhaust Butterfly Valve Actuator Mounting Bolts	6.9	0.70	61 in-lb	
Exhaust Butterfly Valve Actuator Pulley Bolt	4.9	0.50	43 in-lb	
Fuel Pump Bolts	9.8	1.0	87 in-lb	L, S
Nozzle Assy Mounting Bolts	6.9	0.70	61 in-lb	
Nozzle Assy Fuel Hose Screw	4.9	0.50	43 in-lb	
Separator Bracket Mounting Bolt	0.8	0.08	7 in-lb	
Throttle Body Assembly Holder Clamp Bolts	3.0	0.30	27 in-lb	
Throttle Body Holder Bolts	12	1.2	106 in-lb	L
Throttle Cable Holder Plate Bolt	3.9	0.40	35 in-lb	L
Vehicle-down Sensor Bolts	5.9	0.60	52 in-lb	
Water Temperature Sensor	25	2.5	18	SS
<b>Cooling System</b>				
Coolant By-pass Fitting Bolt	8.8	0.90	78 in-lb	L
Coolant Drain Bolt (Cylinder)	9.8	1.0	87 in-lb	
Coolant Drain Bolt (Water Pump)	8.8	0.90	78 in-lb	
Coolant Reserve Tank Mounting Bolts	6.9	0.70	61 in-lb	
Impeller Bolt	9.8	1.0	87 in-lb	
Oil Cooler Mounting Bolts	20	2.0	15	
Radiator Bracket Mounting Bolt	9.8	1.0	87 in-lb	
Radiator Lower Bolt	6.9	0.70	61 in-lb	
Radiator Upper Bolts	9.8	1.0	87 in-lb	
Thermostat Housing Cover Bolts	5.9	0.60	52 in-lb	
Water Hose Clamp Screws	2.0	0.20	17 in-lb	
Water Hose Fitting Bolts (Cylinder)	9.8	1.0	87 in-lb	

## PERIODIC MAINTENANCE 2-7

### Torque and Locking Agent

Fastener	Torque			Remarks
	N-m	kgf-m	ft-lb	
Water Pump Cover Bolts	12	1.2	106 in-lb	L
Water Temperature Sensor	25	2.5	18	SS
<b>Engine Top End</b>				
Air Suction Valve Cover Bolts	9.8	1.0	87 in-lb	L
Camshaft Cap Bolts	12	1.2	106 in-lb	S
Camshaft Chain Tensioner Cap Bolt	20	2.0	15	
Camshaft Chain Tensioner Mounting Bolts	11	1.1	97 in-lb	
Cam Sprocket Mounting Bolts	15	1.5	11	L
Cylinder Head Bolts (M9)	39	4.0	29	MO, S
Cylinder Head Bolts (M6)	12	1.2	106 in-lb	S
Cylinder Head Cover Bolts	9.8	1.0	87 in-lb	
Exhaust Butterfly Valve Actuator Mounting Nuts	6.9	0.70	61 in-lb	
Exhaust Butterfly Valve Actuator Pulley Bolt	4.9	0.50	43 in-lb	
Exhaust Butterfly Valve Cable Adjuster Locknuts	6.9	0.70	61 in-lb	
Exhaust Butterfly Valve Cable Locknuts	6.9	0.70	61 in-lb	
Exhaust Butterfly Valve Cover Bolt	6.9	0.70	61 in-lb	
Exhaust Pipe Clamp Bolt	17	1.7	13	
Exhaust Manifold Holder Nuts	17	1.7	13	
Exhaust Pipe Mounting Bolt	28	2.8	21	
Exhaust Manifold Holder Studs	–	–	–	(stopped)
Front Camshaft Chain Guide Bolt (Lower)	12	1.2	106 in-lb	
Front Camshaft Chain Guide Bolt (Upper)	25	2.5	18	
Muffler Body Clamp Bolt	17	1.7	12	
Muffler Body Mounting Bolts	28	2.8	21	
Muffler Rear Cover Bolts	6.9	0.70	61 in-lb	
Muffler Slide Cover Bolts	6.9	0.70	61 in-lb	
Muffler Upper Cover Bolts	6.9	0.70	61 in-lb	
Upper Camshaft Chain Guide Bolt	12	1.2	106 in-lb	
Spark Plugs	13	1.3	113 in-lb	
Oxygen Sensors	25	2.5	18	
Throttle Body Assy Holder Clamp Bolts	2.9	0.30	26 in-lb	
Throttle Body Holder Bolts	12	1.2	106 in-lb	L
Water Passage Plugs	20	2.0	15	L
<b>Clutch</b>				
Clutch Cover Bolts (M6, L = 40 mm)	9.8	1.0	87 in-lb	
Clutch Cover Bolts (M6, L = 25 mm)	9.8	1.0	87 in-lb	
Clutch Hub Nut	135	14	100	R
Clutch Lever Clamp Bolts	7.8	0.80	69 in-lb	S
Clutch Spring Bolts	8.8	0.90	78 in-lb	
Sub Clutch Hub Bolts	25	2.5	18	L
<b>Engine Lubrication System</b>				
Oil Filler Cap	2.0	0.20	17 in-lb	
Air Bleed Bolt	9.8	1.0	87 in-lb	

## 2-8 PERIODIC MAINTENANCE

### Torque and Locking Agent

Fastener	Torque			Remarks
	N-m	kgf-m	ft-lb	
Engine Oil Drain Bolt	29	3.0	22	
Oil Cooler/Oil Filter Case Mounting Bolts	20	2.0	15	L
Oil Pump Gear Bolt	9.8	1.0	87 in-lb	L
Oil Cooler Mounting Bolts	20	2.0	15	
Oil Filter	31	3.2	23	G, R
Oil Filter Guard Bolts	4.0	0.41	35 in-lb	L
Oil Filter Holder Bolt	25	2.5	18	L
Oil Pan Bolts	9.8	1.0	87 in-lb	S
Oil Passage Nozzle	4.9	0.50	43 in-lb	
Oil Passage Plugs (Taper)	20	2.0	15	L
Oil Passage Plug (Left Side)	17	1.7	13	
Oil Pressure Relief Valve	15	1.5	11	L
Oil Pressure Switch	15	1.5	11	SS
Oil Pressure Switch Terminal Bolt	–	–	–	Hand-tighten
Water Hose Clamp Screws	2.0	0.20	17 in-lb	
Water Pump Cover Bolts	12	1.2	104 in-lb	L
<b>Engine Removal/Installation</b>				
Adjusting Collar Locknut	49	5.0	36	S
Adjusting Collar	9.8	1.0	87 in-lb	S
Lower Engine Mounting Nut	44	4.5	33	S
Middle Engine Mounting Bracket Bolt	25	2.5	18	S
Middle Engine Mounting Nut	44	4.5	33	S
Upper Engine Mounting Bolts	44	4.5	33	S
<b>Crankshaft/Transmission</b>				
Breather Plate Bolts	9.8	1.0	87 in-lb	L
Connecting Rod Big End Nuts	see the text	see the text	see the text	MO
Crankcase Bolts (M8) (Lower) (First)	15	1.5	11	MO, S
Crankcase Bolts (M8) (Lower) (Final)	31	3.2	23	MO, S
Crankcase Bolts (M6, L = 50 mm) (Lower)	12	1.2	104 in-lb	S
Gear Position Switch Screws	2.9	0.30	26 in-lb	L
Crankcase Bolt (M8, L = 90 mm) (Upper)	27	2.8	20	S
Crankcase Bolts (M8, L = 75 mm) (Upper)	27	2.8	20	S
Crankcase Bolts (M6, L = 68 mm) (Upper)	12	1.2	104 in-lb	S
Transmission Case Bolts (M8)	20	2.0	15	
Transmission Case Bolts (M6)	9.8	1.0	87 in-lb	
Piston Oil Nozzles	2.9	0.30	26 in-lb	
Gear Positioning Lever Bolt	12	1.2	104 in-lb	
Oil Passage Plugs (Taper Side)	20	2.0	15	L
Oil Passage Plug (Left Side)	17	1.7	13	
Oil Pressure Switch	15	1.5	11	SS
Fitting (breather)	15	1.5	11	L
Oil Passage Nozzle	4.9	0.50	43 in-lb	

## PERIODIC MAINTENANCE 2-9

### Torque and Locking Agent

Fastener	Torque			Remarks
	N-m	kgf-m	ft-lb	
Oil Pressure Switch Terminal Bolt	–	–	–	Hand-tighten
Bearing Holder Screws	4.9	0.50	43 in-lb	L
Shift Drum Cam Holder Bolt	12	1.2	104 in-lb	L
Shift Lever Bolt	6.9	0.70	61 in-lb	
Shift Pedal Mounting Bolt	25	2.5	18	
Shift Shaft Return Spring Pin	28	2.9	21	L
Shift Tie-Rod Locknuts	6.9	0.70	61 in-lb	
Starter Clutch Bolt	49	5.0	36	
Starter Clutch Bolt Cap	–	–	–	Hand-tighten
Timing Inspection Cap	–	–	–	Hand-tighten
Starter Clutch Cover Bolts	9.8	1.0	87 in-lb	
Idle Gear Cover Bolts	9.8	1.0	87 in-lb	
<b>Wheels/Tires</b>				
Front Axle Clamp Bolts	20	2.0	15	AL
Front Axle Nut	127	13	94	
Rear Axle Nut	127	13	94	
<b>Final Drive</b>				
Engine Sprocket Cover Bolts	9.8	1.0	87 in-lb	
Engine Sprocket Nut	125	13	92	MO
Rear Sprocket Nuts	59	6.0	43	
Chain Guide Bolts (Front)	9.8	1.0	87 in-lb	L
Chain Guide Bolt (Rear)	4.9	0.50	43 in-lb	L
<b>Brakes</b>				
Caliper Bleed Valves	7.8	0.80	69 in-lb	
Brake Hose Banjo Bolts	25	2.5	18	
Brake Lever Pivot Bolt	1.0	0.10	9 in-lb	Si
Brake Lever Pivot Bolt Locknut	5.9	0.60	52 in-lb	
Brake Pedal Bolt	8.8	0.90	78 in-lb	
Front Brake Light Switch Screw	1.2	0.12	10 in-lb	
Front Brake Reservoir Cap Stopper Screw	1.2	0.12	10 in-lb	
Front Brake Disc Mounting Bolts	27	2.8	20	L
Front Brake Pad Pins	17	1.7	13	
Front Caliper Assembly Bolts	27	2.8	20	
Front Caliper Mounting Bolts	34	3.5	25	
Front Master Cylinder Bleed Valve	5.9	0.60	52 in-lb	
Front Master Cylinder Clamp Bolts	11	1.1	97 in-lb	S
Rear Brake Disc Mounting Bolts	27	2.8	20	L
Rear Caliper Mounting Bolts	25	2.5	18	
Rear Master Cylinder Mounting Bolts	25	2.5	18	
Rear Master Cylinder Push Rod Locknut	18	1.8	13	
<b>Suspension</b>				
Front Axle Clamp Bolts	20	2.0	15	AL
Front Fork Bottom Allen Bolts	34	3.5	25	

## 2-10 PERIODIC MAINTENANCE

### Torque and Locking Agent

Fastener	Torque			Remarks	
	N-m	kgf-m	ft-lb		
Front Fork Clamp Bolts (Lower)	25	2.5	18	AL	
Front Fork Clamp Bolts (Upper)	20	2.0	15		
Front Fork Top Plugs	34	3.5	25		
Piston Rod Nuts	20	2.0	15		
Rear Shock Absorber Bracket Nut	59	6.0	43		
Rear Shock Absorber Nut (Lower)	34	3.5	25		
Rear Shock Absorber Nut (Upper)	34	3.5	25		
Swingarm Pivot Adjusting Collar	20	2.0	15		S
Swingarm Pivot Adjusting Collar Locknut	98	10	72		S
Swingarm Pivot Shaft Nut	108	11	81		S
Tie-Rod Nuts	59	6.0	43		
Uni-Trak Rocker Arm Nut	34	3.5	25		
<b>Steering</b>					
Front Fork Clamp Bolts (Lower)	25	2.5	18	AL	
Front Fork Clamp Bolts (Upper)	20	2.0	15		
Handlebar Bolts	25	2.5	18	L	
Handlebar Position Bolts	9.8	1.0	87 in-lb		
Steering Stem Head Nut	78	8.0	58		
Steering Stem Nut	20	2.0	15		
Switch Housing Screws	3.5	0.36	31 in-lb		
<b>Frame</b>					
Front Fender Mounting Bolts	3.9	0.40	35 in-lb	L G L L	
Front Footpeg Bracket Bolts	25	2.5	18		
Rear Footpeg Bracket Bolts	25	2.5	18		
Rear Frame Bolts	44	4.5	32		
Sidestand Bolt	44	4.5	32		
Sidestand Bracket Bolts	49	5.0	36		
Sidestand Switch Bolt	8.8	0.90	78 in-lb		
Windshield Mounting Bolts	0.4	0.04	4 in-lb		
<b>Electrical System</b>					
Alternator Cover Bolts	9.8	1.0	87 in-lb	L	
Alternator Lead Holding Plate Bolt	9.8	1.0	87 in-lb		
Alternator Rotor Bolt	155	16	115		
Camshaft Position Sensor Bolt	9.8	1.0	87 in-lb		
Crankshaft Sensor Bolts	5.9	0.60	52 in-lb		
Cylinder Head Cover Ground Bolt	9.8	1.0	87 in-lb		
Front Brake Light Switch Screw	1.2	0.12	10 in-lb		
Front Turn Signal Light Mounting Screws	1.2	0.12	10 in-lb		
Headlight Mounting Screws	1.2	0.12	10 in-lb		
Licence Plate Light Cover Screws	0.9	0.09	8 in-lb		
Licence Plate Mounting Screws	1.2	0.12	10 in-lb		
Meter Mounting Screws	1.2	0.12	10 in-lb		
Gear Position Switch Screws	2.9	0.30	26 in-lb		



**Torque and Locking Agent**

Fastener	Torque			Remarks
	N-m	kgf-m	ft-lb	
Rear Turn Signal Light Lens Screws	1.0	0.10	9 in-lb	
Rear Turn Signal Light Mounting Screws	1.2	0.12	10 in-lb	
Regulator/Rectifier Bolts	6.9	0.70	61 in-lb	
Regulator/Rectifier Bracket Nuts	6.9	0.70	61 in-lb	
Side Stand Switch Bolt	8.8	0.90	78 in-lb	L
Spark Plugs	13	1.3	113 in-lb	
Speed Sensor Bolt	6.9	0.70	61 in-lb	L
Stator Coil Bolts	12	1.2	106 in-lb	L
Starter Motor Cable Terminal Bolt	2.9	0.30	26 in-lb	
Starter Clutch Bolt	49	5.0	36	
Starter Motor Mounting Bolts	9.8	1.0	87 in-lb	
Starter Relay Cable Terminal Bolts	4.0	0.41	35 in-lb	
Switch Housing Screws	3.5	0.36	31 in-lb	
Tail/Brake Light Mounting Bolts	4.0	0.40	35 in-lb	
Vehicle-down Sensor Bolts	5.9	0.60	52 in-lb	
Water Temperature Sensor	25	2.5	18	SS
Idle Gear Cover Bolts	9.8	1.0	87 in-lb	
Starter Clutch Cover Bolts	9.8	1.0	87 in-lb	
Starter Clutch Bolt Cap	–	–	–	Hand-tighten
Timing Inspection Cap	–	–	–	Hand-tighten

The table below, relating tightening torque to thread diameter, lists the basic torque for the bolts and nuts. Use this table for only the bolts and nuts which do not require a specific torque value. All of the values are for use with dry solvent-cleaned threads.

**Basic Torque for General Fasteners**

Threads Diameter (mm)	Torque		
	N-m	kgf-m	ft-lb
5	3.4 ~ 4.9	0.35 ~ 0.50	30 ~ 43 in-lb
6	5.9 ~ 7.8	0.60 ~ 0.80	52 ~ 69 in-lb
8	14 ~ 19	1.4 ~ 1.9	10 ~ 13.5
10	25 ~ 34	2.6 ~ 3.5	19 ~ 25
12	44 ~ 61	4.5 ~ 6.2	33 ~ 45
14	73 ~ 98	7.4 ~ 10.0	54 ~ 72
16	115 ~ 155	11.5 ~ 16.0	83 ~ 115
18	165 ~ 225	17.0 ~ 23.0	125 ~ 165
20	225 ~ 325	23.0 ~ 33.0	165 ~ 240

## 2-12 PERIODIC MAINTENANCE

### Specifications

Item	Standard	Service Limit
<b>Fuel System (DFI)</b>		
Throttle Grip Free Play	2 ~ 3 mm (0.08 ~ 0.12 in.)	---
Idle Speed	1 300 ±50 r/min (rpm)	---
Throttle Body Vacuum	27.3 ±1.333 kPa (205 ±10 mmHg) at idle speed	---
Air Cleaner Element	Viscous paper element	---
<b>Cooling System</b>		
Coolant:		
Type (Recommended)	Permanent type antifreeze	---
Color	Green	---
Mixed Ratio	Soft water 50%, coolant 50%	---
Freezing Point	-35°C (-31°F)	---
Total Amount	2.6 L (2.7 US qt)	---
<b>Engine Top End</b>		
Valve Clearance:		
Exhaust	0.24 ~ 0.31 mm (0.0094 ~ 0.0122 in.)	---
Inlet	0.13 ~ 0.19 mm (0.0051 ~ 0.0075 in.)	---
<b>Clutch</b>		
Clutch Lever Free Play	2 ~ 3 mm (0.08 ~ 0.12 in.)	---
<b>Engine Lubrication System</b>		
Engine Oil:		
Type	API SE, SF or SG API SH, SJ or SL with JASO MA	---
Viscosity	SAE 10W-40	---
Capacity	2.9 L (3.1 US qt) (when filter is not removed)	---
	3.2 L (3.4 US qt) (when filter is removed)	---
	3.8 L (4.0 US qt) (when engine is completely dry)	---
Level	Between upper and lower level lines (Wait 2 ~ 3 minutes after idling or running)	---
<b>Wheels/Tires</b>		
Tread Depth:		
Front	BRIDGESTONE: 3.6 mm (0.14 in.)	1 mm (0.04 in.), (AT, CH, DE) 1.6 mm (0.06 in.)
Rear	BRIDGESTONE: 4.8 mm (0.19 in.)	Up to 130 km/h (80 mph): 2 mm (0.08 in.), Over 130 km/h (80 mph): 3 mm (0.12 in.)
Air Pressure (when Cold):		
Front	Up to 180 kg (397 lb) load: 250 kPa (2.5 kgf/cm <sup>2</sup> , 36 psi)	---
Rear	Up to 180 kg (397 lb) load: 290 kPa (2.9 kgf/cm <sup>2</sup> , 42 psi)	---

**Specifications**

Item	Standard	Service Limit
<b>Final Drive</b>		
Drive Chain Slack	30 ~ 40 mm (1.2 ~ 1.6 in.)	— — —
Drive Chain Wear (20-link Length)	317.5 ~ 318.2 mm (12.50 ~ 12.53 in.)	323 mm (12.7 in.)
Standard Chain:		
Make	ENUMA	— — —
Type	EK520MVXL1	— — —
Link	112 links	— — —
<b>Brakes</b>		
Brake Fluid:		
Grade	DOT4	— — —
Brake Pad Lining Thickness:		
Front	4 mm (0.16 in.)	1 mm (0.04 in.)
Rear	5 mm (0.20 in.)	1 mm (0.04 in.)
Brake Light Timing:		
Front	Pulled ON	— — —
Rear	On after about 10 mm (0.39 in.) of pedal travel	— — —

# 2-14 PERIODIC MAINTENANCE

## Special Tools

**Inside Circlip Pliers:**

**57001-143**

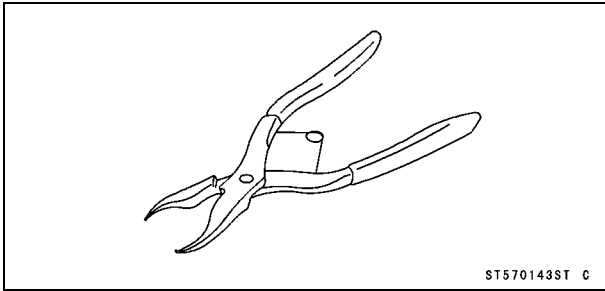

**Oil Filter Wrench:**

**57001-1249**

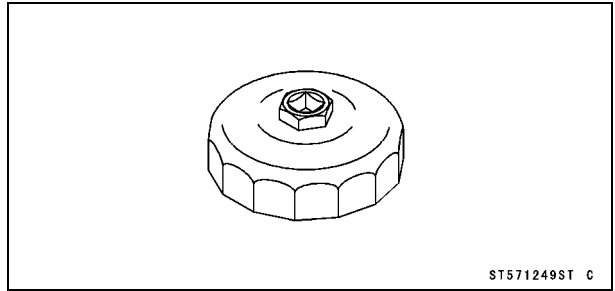

**Steering Stem Nut Wrench:**

**57001-1100**

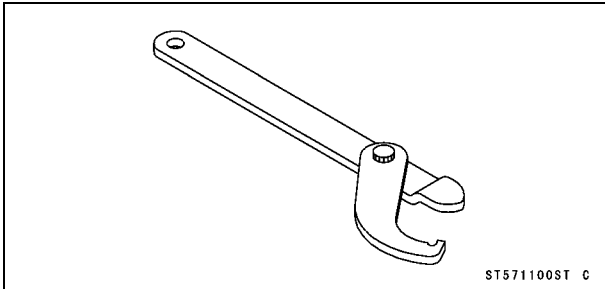

**Vacuum Gauge:**

**57001-1369**

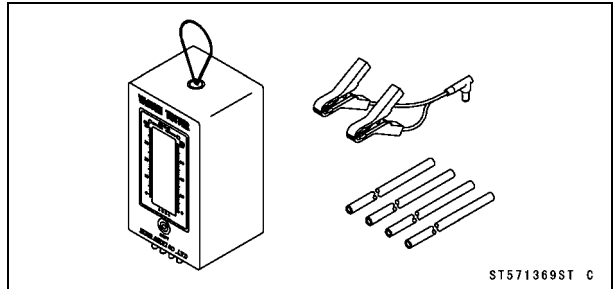

**Jack:**

**57001-1238**

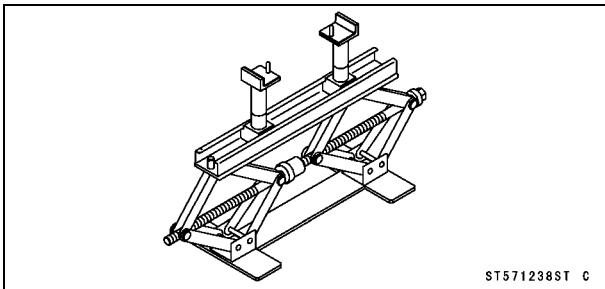

**Extension Tube:**

**57001-1578**

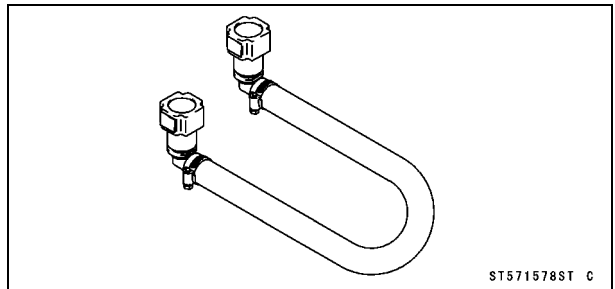

**Pilot Screw Adjuster, A:**

**57001-1239**

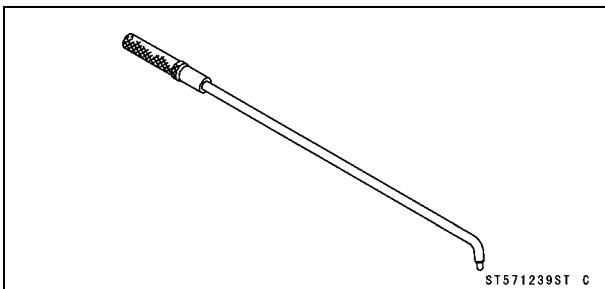

**Jack Attachment:**

**57001-1608**

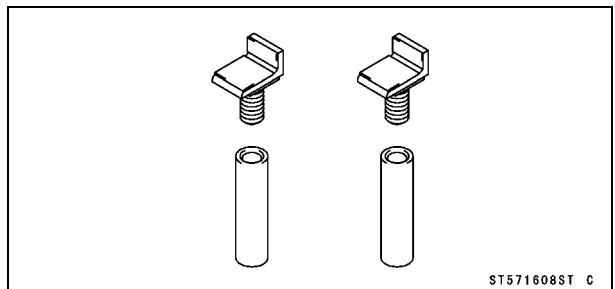

**Maintenance Procedure**

**Fuel System (DFI)**

**Throttle Control System Inspection**

- Check that the throttle grip [B] moves smoothly from full open to close, and the throttle closes quickly and completely by the return spring in all steering positions.
- ★ If the throttle grip does not return properly, check the throttle cables routing, grip free play, and cable damage. Then lubricate the throttle cable.
- Check the throttle grip free play [A].

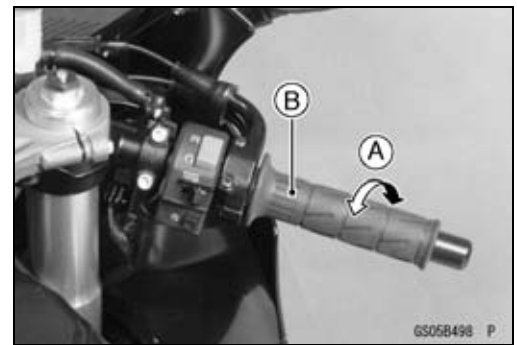

**Throttle Grip Free Play**

**Standard: 2 ~ 3 mm (0.08 ~ 0.12 in.)**

- ★ If the free play is incorrect, adjust the throttle cable as follows.
  - Loosen the locknuts [A] [B].
  - Screw both throttle cable adjusters [C] [D] to give the throttle grip plenty of play.
  - Turn the decelerator cable adjuster [C] until 2 ~ 3 mm (0.08 ~ 0.12 in.) of throttle grip play is obtained.
  - Tighten the locknut [A].
  - Turn the accelerator cable adjuster [D] until 2 ~ 3 mm (0.08 ~ 0.12 in.) of throttle grip play is obtained.
  - Tighten the locknut [B].
- ★ If the free play can not be adjusted with the adjusters, replace the cable.

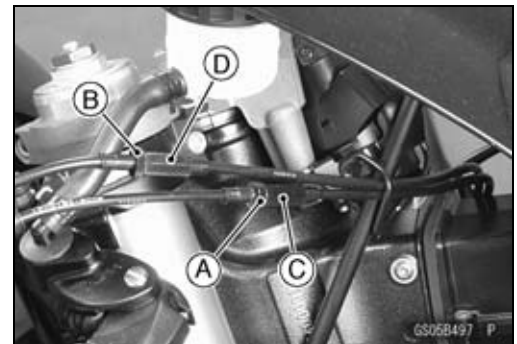

**Engine Vacuum Synchronization Inspection**

**NOTE**

○ These procedures are explained on the assumption that the inlet and exhaust systems of the engine are in good condition.

- Situate the motorcycle so that it is vertical.
- Remove:
  - Fuel Tank (see Fuel Tank Removal in the Fuel System (DFI) chapter)
  - Air Cleaner Housing (see Air Cleaner Housing Removal in the Fuel System (DFI) chapter)
  - Fuel Hose (see Fuel Hose Replacement in the Periodic Maintenance chapter)
- When removing the air cleaner housing, do not remove the inlet air pressure sensor hose.
- Pull off the rubber caps [A] from the fittings of each throttle body.
- For the California Model, pull off the vacuum hose [B].

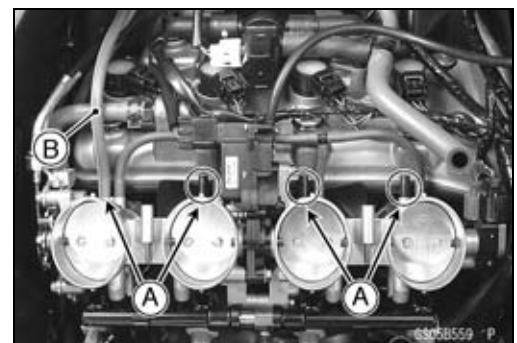

## 2-16 PERIODIC MAINTENANCE

### Maintenance Procedure

- Connect a vacuum gauge (special tool) and hoses [A] to the fittings on the throttle body.

**Special Tool - Vacuum Gauge: 57001-1369**

- Connect a highly accurate tachometer lead [B] to one of the stick coil primary lead.

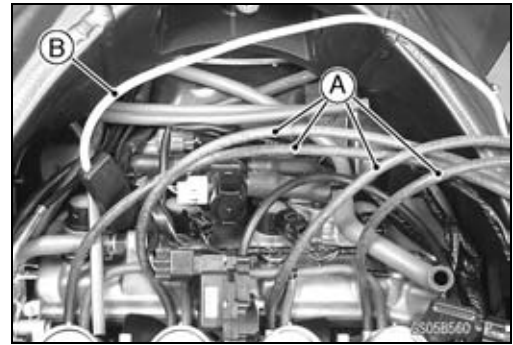

- Plug the air switching valve hose end [A] and air cleaner housing fitting [B].

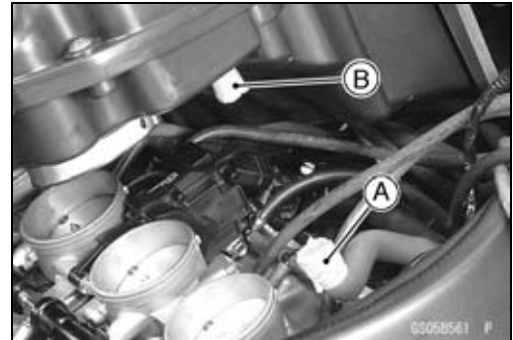

- Install the air cleaner housing (see Air Cleaner Housing Installation in the Fuel System (DFI) chapter).

- Connect the following parts temporary.
  - Fuel Pump Lead Connector [A]
  - Extension Tube [B]

**Special Tool - Extension Tube: 57001-1578**



- Start the engine and warm it up thoroughly.
- Check the idle speed, using a highly accurate tachometer [A].

#### Idle Speed

**Standard: 1 300 ±50 r/min (rpm)**

- ★ If the idle speed is out of the specified range, adjust it with the adjusting screw (see Idle Speed Adjustment).

#### CAUTION

**Do not measure the idle speed by the tachometer of the meter unit.**

- When idling the engine, inspect the throttle body vacuum, using the vacuum gauge [B].

#### Engine Vacuum

**Standard: 27.3 ±1.333 kPa (205 ±10 mmHg) at idle speed**

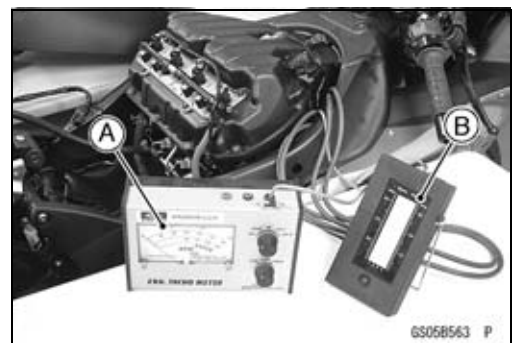

**Maintenance Procedure**

★If any vacuum is not within the specifications, first synchronize the balance of the left (#1, #2 throttle valves) and right (#3, #4 throttle valves) assemblies.

**Example:**

- #1: 165 mmHg
- #2: 190 mmHg
- #3: 170 mmHg
- #4: 200 mmHg

●With the engine at the correct idle speed, equalize the highest vacuum of #3 and #4 (example 200 mmHg) to the highest vacuum of #1 and #2 (example 190 mmHg) by turning the center adjusting screw [A].

Rear View [B]

**NOTE**

○After adjustment, the final vacuum measurement between the lowest throttle valves may not be 205 mmHg (in this example). The goal is to have the lower two vacuums between the left (#1 and #2) and right (#3 and #4) banks be the same.

- Open and close the throttle after each measurement and adjust the idle speed as necessary.
- Once the throttle valves have been synchronized, inspect the main throttle sensor output voltage to ensure proper operation (procedure is at the end of this section).

★If any one vacuum measurement is out of the standard measurement after left and right synchronization, turn in the bypass screws [A] until it seats fully but not tightly.

Rear View [B]

**Special Tool - Pilot Screw Adjuster, A [C]: 57001-1239**

**CAUTION**

**Do not over tighten them. They could be damaged, requiring replacement.**

- Turn out the bypass screw of the higher vacuum between #1 and #2 to the lower vacuum.
- Turn out the bypass screw of the higher vacuum between #3 and #4 to the lower vacuum.
- Open and close the throttle valves after each measurement and adjust the idle speed as necessary.
- Inspect the vacuums as before.
- ★If all vacuums are within the specification, finish the engine vacuum synchronization.
- ★If any vacuum can not be adjusted within the specification, remove the bypass screws #1 ~ #4 and clean them.

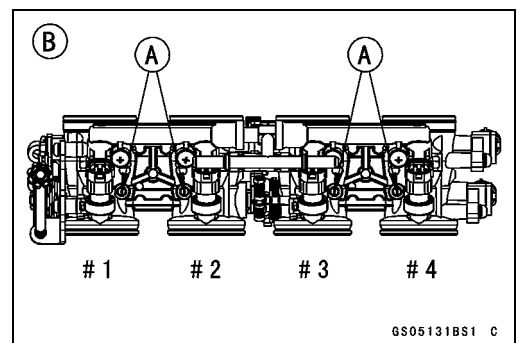
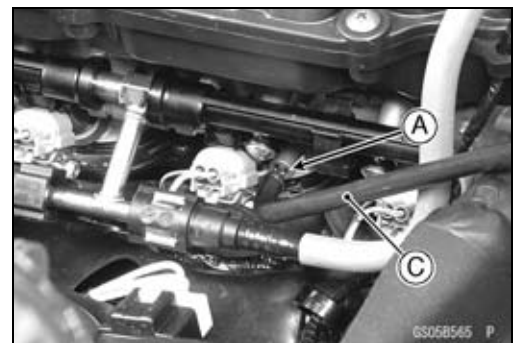
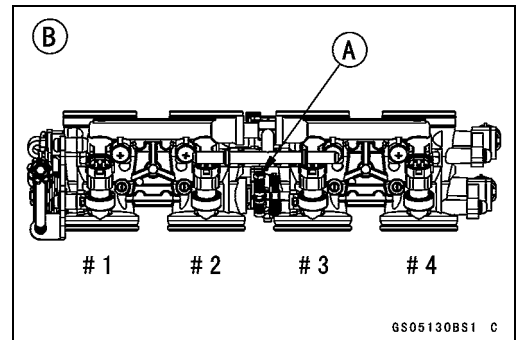
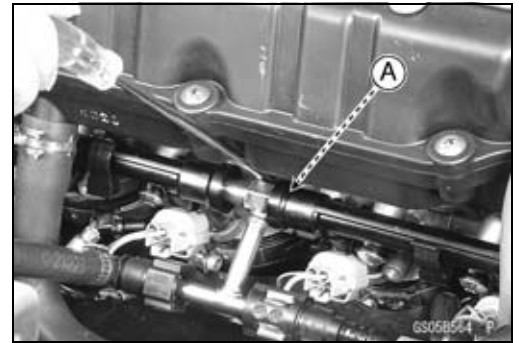

## 2-18 PERIODIC MAINTENANCE

### Maintenance Procedure

- Remove the bypass screw [A], spring [B], washer [C] and O-ring [D].
- Check the bypass screw and its hole for carbon deposits.
- ★ If any carbon accumulates, wipe the carbon off the bypass screw and the hole, using a cotton pad penetrated with a high-flash point solvent.
- Replace the O-ring with a new one.
- Check the tapered portion [E] of the bypass screw for wear or damage.
- ★ If the bypass screw is worn or damaged, replace it.
- Turn in the bypass screw until it seats fully but not tightly.
  
- Repeat the same procedure for other bypass screws.
- Repeat the synchronization.
- ★ If the vacuums are correct, check the output voltage of the main throttle sensor (see Output Voltage Inspection of the Main Throttle Sensor in the Fuel System (DFI) chapter).

**Special Tool - Throttle Sensor Setting Adapter: 57001-1538**

#### Main Throttle Sensor Output Voltage

##### Connections to Sensor

Meter (+) → Y/W lead

Meter (-) → BR/BK lead

**Standard: DC 1.025 ~ 1.055 V (at idle throttle opening)**

- ★ If the output voltage is out of the standard, check the input voltage of the main throttle sensor (see Input Voltage Inspection of the Main Throttle Sensor in the Fuel System (DFI) chapter).
- Remove the vacuum gauge hoses and install the rubber caps on the original position.
- For the California Model, install the vacuum hose.
- Route the vacuum hose according to Cable, Wire, and Hose Routing section in the Appendix chapter.

#### Idle Speed Inspection

- Start the engine and warm it up thoroughly.
- With the engine idling, turn the handlebar to both sides [A].
- ★ If handlebar movement changes the idle speed, the throttle cables may be improperly adjusted or incorrectly routed, or damaged. Be sure to correct any of these conditions before riding (see Idle Speed Inspection and Cable, Wire, and Hose Routing section in the Appendix chapter).

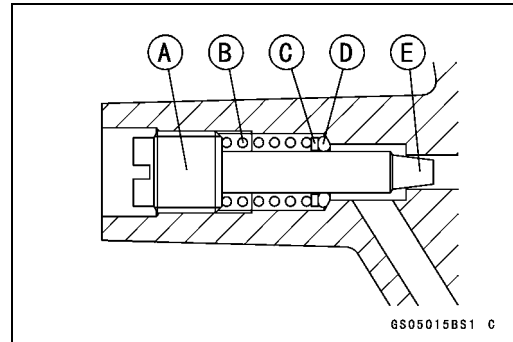

### **⚠ WARNING**

**Operation with improperly adjusted, incorrectly routed, or damaged cables could result in an unsafe riding condition.**

- Check the idle speed.

#### Idle Speed

**Standard: 1 300 ±50 r/min (rpm)**

- ★ If the idle speed is out of the specified range, adjust it.



**Maintenance Procedure**

**Idle Speed Adjustment**

- Start the engine and warm it up thoroughly.
- Turn the adjusting screw [A] until the idle speed is correct.
- Open and close the throttle a few times to make sure that the idle speed is within the specified range. Readjust if necessary.

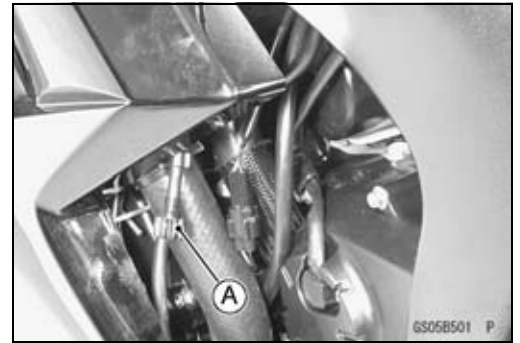

**Fuel Hose Inspection (fuel leak, damage, installation condition)**

- If the motorcycle is not properly handled, the high pressure inside the fuel line can cause fuel to leak [A] or the hose to burst. Remove the fuel tank (see Fuel Tank Removal in the Fuel System (DFI) chapter) and check the fuel hose.
- ★ Replace the fuel hose if any fraying, cracks [B] or bulges [C] are noticed.

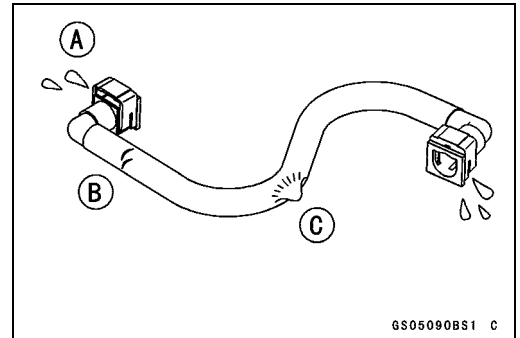

- Check that the hose joints are securely connected.
- Check that the hoses are routed according to Cable, Wire, and Hose Routing section in the Appendix chapter.
- ★ Replace the hose if it has been sharply bent or kinked.
- ★ If it does not lock, reinstall the hose joint.

**Evaporative Emission Control System Inspection (California Model)**

- Inspect the canister as follows.
- Remove:
  - Left Inner Cover (see Inner Cover Removal in the Frame chapter)
- Remove the canister [A], and disconnect the hoses from the canister.
- Visually inspect the canister for cracks or other damage.
- ★ If the canister has any cracks or bad damage, replace it with a new one.

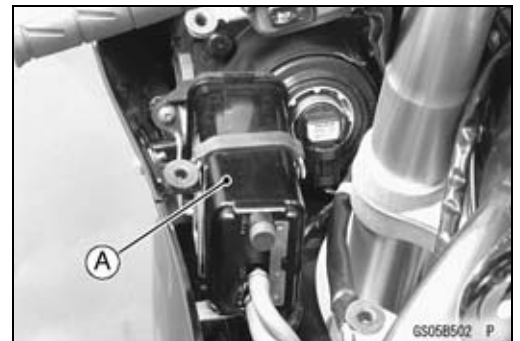

**NOTE**

- The canister is designed to work well through the motorcycle's life without any maintenance if it is used under normal conditions.

## 2-20 PERIODIC MAINTENANCE

### Maintenance Procedure

- Check the liquid/vapor separator as follows.
- Remove:
  - Left Middle Fairing (see Middle Fairing Removal in the Frame chapter)
- Disconnect the hoses from the separator, and remove the separator [A] from the motorcycle left side.
- Visually inspect the separator for cracks and other damage.
- ★ If the separator has any cracks or damage, replace it with a new one.
- To prevent the gasoline from flowing into or out of the canister, hold the separator perpendicular to the ground.
- Check the hoses of the evaporative emission control system as follows.
- Check that the hoses are securely connected and clips are in position.
- Replace any kinked, deteriorated or damaged hoses.
- Route the hoses according to Cable, Wire, and Hose Routing section in the Appendix chapter.
- When installing the hoses, avoid sharp bending, kinking, flattening or twisting, and route the hoses with a minimum of bending so that the emission flow will not be obstructed.

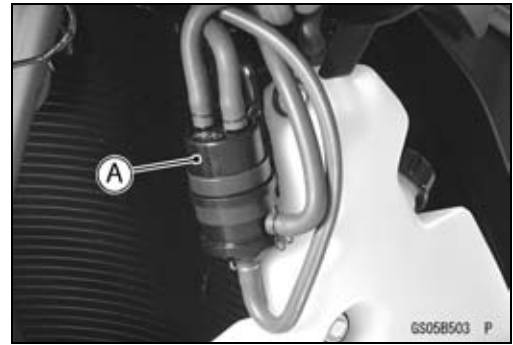

### Engine Top End

#### Valve Clearance Inspection

##### NOTE

- Valve clearance must be checked and adjusted when the engine is cold (at room temperature).

- Remove the cylinder head cover (see Cylinder Head Cover Removal in the Engine Top End chapter).
- Remove the timing inspection cap [A] and starter clutch bolt cap [B] on the starter clutch cover [C].

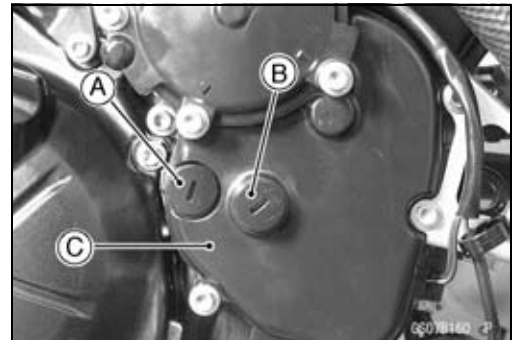

- Using a wrench, turn the starter clutch bolt [A] counterclockwise until the line [B] (TDC mark for #1,4 pistons) on the starter clutch is aligned with the notches [C] in the edge of the timing inspection hole in the starter clutch cover.

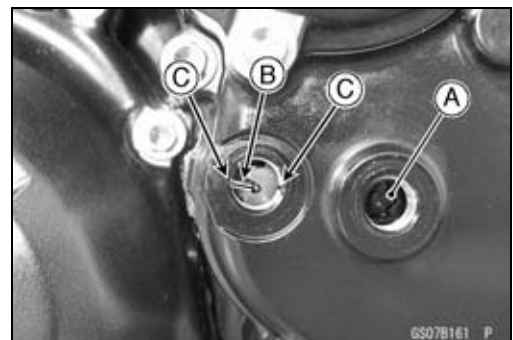

**Maintenance Procedure**

- Using a thickness gauge [A], measure the valve clearance between the cam and the valve lifter.

**Valve Clearance**

**Standard:**

- Exhaust** 0.24 ~ 0.31 mm (0.0094 ~ 0.0122 in.)
- Inlet** 0.13 ~ 0.19 mm (0.0051 ~ 0.0075 in.)



**NOTE**

- Thickness gauge is horizontally inserted on the valve lifter.

- Good [A]
- Bad [B]
- Thickness Gauge [C]
- Horizontally Inserts [D]
- Cam [E]
- Valve Lifter [F]
- Hits the Valve Lifter Ahead [G]

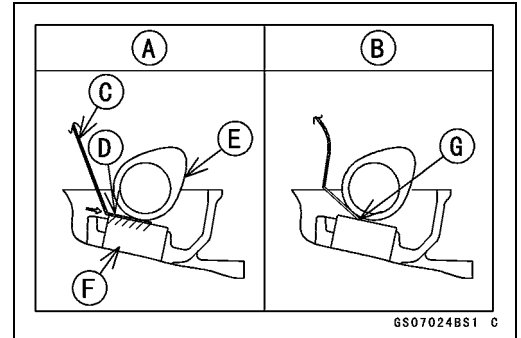

- When positioning #1 piston TDC at the end of the compression stroke:

- Inlet Valve Clearance of #1 and #3 Cylinders
- Exhaust Valve Clearance of #1 and #2 Cylinders
- Measuring Valve [A]

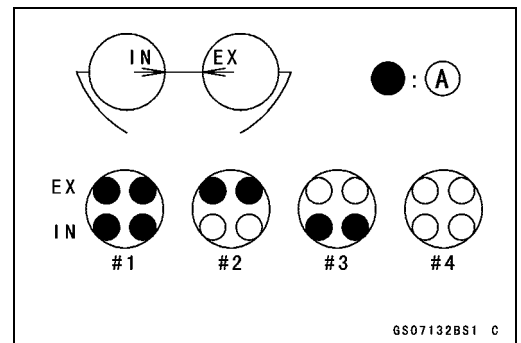

- When positioning #4 piston TDC at the end of the compression stroke:

- Inlet Valve Clearance of #2 and #4 Cylinders
- Exhaust Valve Clearance of #3 and #4 Cylinders
- Measuring Valve [A]

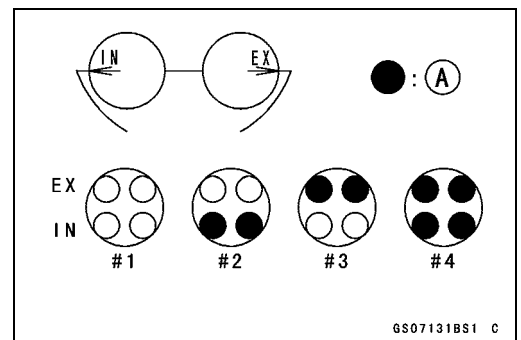

- ★ If the valve clearance is not within the specified range, first record the clearance, and then adjust it.

- Filling engine oil to all pockets front side of the cam lobes of the camshaft.

- Inlet Side Oil Pockets [A]
- Exhaust Side Oil Pockets [B]

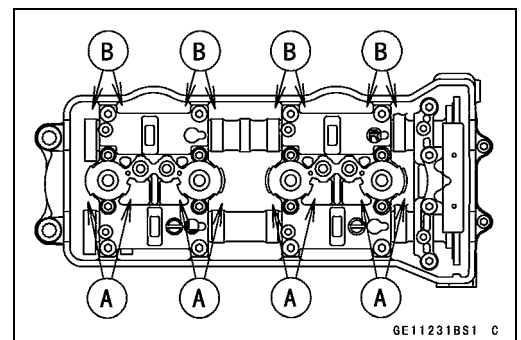

## 2-22 PERIODIC MAINTENANCE

### Maintenance Procedure

#### Valve Clearance Adjustment

- To change the valve clearance, remove the camshaft chain tensioner, camshafts and valve lifters. Replace the shim with one of a different thickness.

#### NOTE

- Mark and record the locations of the valve lifters and shims so that they can be reinstalled in their original positions.

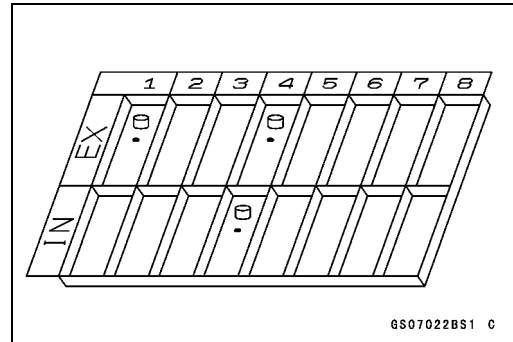

- Clean the shim to remove any dust or oil.
- Measure the thickness of the removed shim [A].
- Select a new shim thickness calculation as follows.
  - a + b - c = d
  - [a] Present Shim Thickness
  - [b] Measured Valve Clearance
  - [c] Specified Valve Clearance (Mean Value = 0.16)
  - [d] Replace Shim Thickness

#### Example:

$$1.600 + 0.33 - 0.16 = 1.77 \text{ mm}$$

- Exchange the shim for the 1.775 size shim.

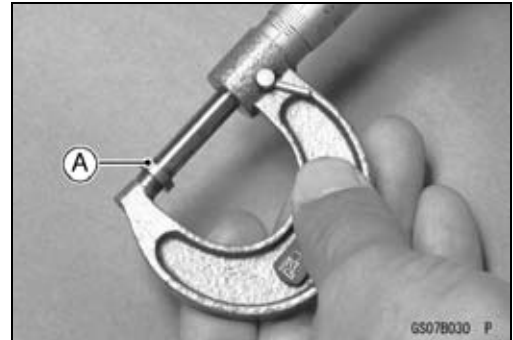

#### CAUTION

**Don't use the shims for another models. This could cause wear of the valve stem end, and valve stem damage.**

**Maintenance Procedure**

**Adjustment Shims**

Thickness	Part Number	Mark
1.300	92180-0108	130
1.325	92180-0109	132
1.350	92180-0110	135
1.375	92180-0111	138
1.400	92180-0112	140
1.425	92180-0113	142
1.450	92180-0114	145
1.475	92180-0115	148
1.500	92180-0116	150
1.525	92180-0117	152
1.550	92180-0118	155
1.575	92180-0119	158
1.600	92180-0120	160
1.625	92180-0121	162
1.650	92180-0122	165
1.675	92180-0123	168
1.700	92180-0124	170
1.725	92180-0125	172
1.750	92180-0126	175
1.775	92180-0127	178
1.800	92180-0128	180
1.825	92180-0129	182
1.850	92180-0130	185
1.875	92180-0131	188
1.900	92180-0132	190
1.925	92180-0133	192
1.950	92180-0134	195
1.975	92180-0135	198
2.000	92180-0136	200
2.025	92180-0137	202
2.050	92180-0138	205
2.075	92180-0139	208
2.100	92180-0140	210
2.125	92180-0141	212
2.150	92180-0142	215
2.175	92180-0143	218
2.200	92180-0144	220
2.225	92180-0145	222
2.250	92180-0146	225
2.275	92180-0147	228
2.300	92180-0148	230

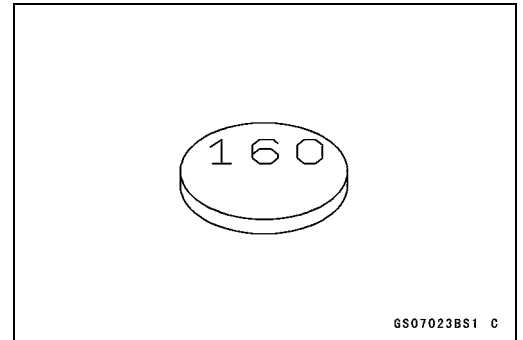

## 2-24 PERIODIC MAINTENANCE

### Maintenance Procedure

#### CAUTION

**Be sure to remeasure the clearance after selecting a shim. The clearance can be out of the specified range because of the shim tolerance.**

○ If there is no valve clearance, use a shim that is a few sizes smaller, and remeasure the valve clearance.

- When installing the shim, face the marked side toward the valve lifter. At this time, apply engine oil to the shim or the valve lifter to keep the shim in place during camshaft installation.

#### CAUTION

**Do not put shim stock under the shim. This may cause the shim to pop out at high rpm, causing extensive engine damage.**  
**Do not grind the shim. This may cause it to fracture, causing extensive engine damage.**

- Apply molybdenum disulfide oil solution to the valve lifter surface and install the lifter.
- Install the camshafts (see Camshaft Installation in the Engine Top End chapter).
- Recheck the valve clearance and readjust if necessary.
- Filling engine oil to all oil pockets front side of the cam lobes of the camshafts.
  - Inlet Side Oil Pockets [A]
  - Exhaust Side Oil Pockets [B]
- Install the removed parts.

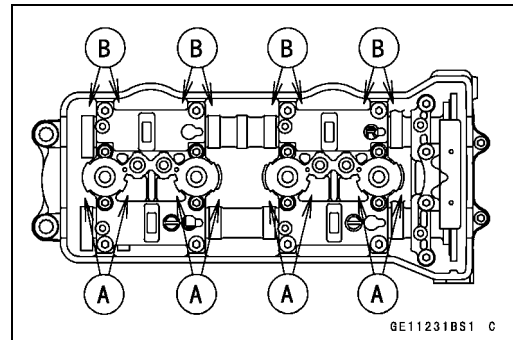

#### **Air Suction System Damage Inspection**

- Set up the fuel tank (see the Air Cleaner Element Replacement).
- Pull the air switching valve hose [A] out of the air cleaner.
- Start the engine and run it at idle speed.
- Plug [B] the air switching valve hose end with your finger and feel vacuum pulsing in the hose.
- ★ If there is no vacuum pulsation, check the hose line for leak. If there is no leak, check the air switching valve (see Air Switching Valve Unit Test in the Electrical System chapter) or air suction valve (see Air Suction Valve Inspection in the Engine Top End chapter).

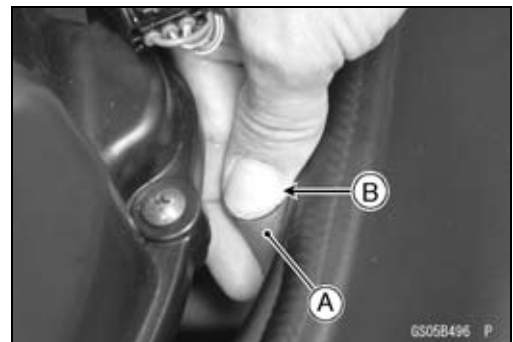

**Maintenance Procedure**

**Cooling System**

**Coolant Level Inspection**

**NOTE**

○ Check the level when the engine is cold (room or ambient temperature).

- Check the coolant level in the reserve tank [A] with the motorcycle held perpendicular (Do not use the side stand).
- ★ If the coolant level is lower than the “L” level line [B], unscrew the reserve tank cap and add coolant to the “F” level line [C].

“L”: low

“F”: full

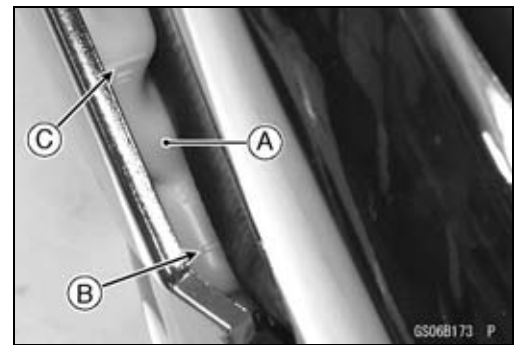

**CAUTION**

For refilling, add the specified mixture of coolant and soft water. Adding water alone dilutes the coolant and degrades its anticorrosion properties. The diluted coolant can attack the aluminum engine parts. In an emergency, soft water alone can be added. But the diluted coolant must be returned to the correct mixture ratio within a few days. If coolant must be added often or the reserve tank has run completely dry, there is probably leakage in the cooling system. Check the system for leaks. Coolant ruins painted surfaces. Immediately wash away any coolant that spills on the frame, engine, wheels or other painted parts.

**Radiator Hose Damage and Installation Condition Inspection**

○ The high pressure inside the radiator hose can cause coolant to leak [A] or the hose to burst if the line is not properly maintained. Visually inspect the hoses for signs of deterioration. Squeeze the hoses. A hose should not be hard and brittle, nor should it be soft or swollen.

★ Replace the hose if any fraying, cracks [B] or bulges [C] are noticed.

● Check that the hoses are securely connected and clamps are tightened correctly.

**Torque - Water Hose Clamp Screws: 2.0 N-m (0.20 kgf-m, 17 in-lb)**

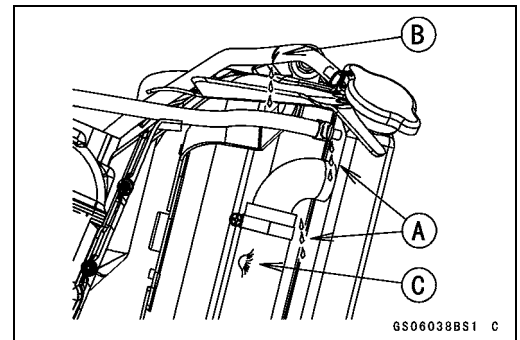

## 2-26 PERIODIC MAINTENANCE

### Maintenance Procedure

#### Clutch

##### Clutch Operation Inspection

- Pull the clutch lever just enough to take up the free play [A].
- Measure the gap between the lever and the lever holder.
- ★ If the gap is too wide, the clutch may not release fully. If the gap is too narrow, the clutch may not engage fully. In either case, adjust it.

##### Clutch Lever Free Play

Standard: 2 ~ 3 mm (0.08 ~ 0.12 in.)

#### ⚠ WARNING

To avoid a serious burn, never touch the engine or exhaust pipe during clutch adjustment.

- Turn the adjuster [A] so that 4 ~ 6 mm (0.16 ~ 0.24 in.) [B] of threads is visible.

- Slide the dust cover [A] at the clutch cable lower end out of place.
- Loosen both adjusting nuts [B] at the clutch cover as far as they will go.
- Pull the clutch outer cable [C] tight and tighten the adjusting nuts against the bracket [D].
- Slip the rubber dust cover back onto place.
- Turn the adjuster at the clutch lever until the free play is correct.

- Push the release lever [A] toward the front of the motorcycle until it becomes hard to turn.

○ At this time, the release lever should have the proper angle shown.

60° [B]

- ★ If the angle is wrong, check the clutch and release parts for wear.

#### ⚠ WARNING

Be sure that the outer cable end at the clutch lever is fully seated in the adjuster at the clutch lever, or it could slip into place later, creating enough cable play to prevent clutch disengagement.

- After the adjustment, start the engine and check that the clutch does not slip and that it releases properly.

- ★ If the clutch operation is insufficiency, inspect the clutch system.

#### ⚠ WARNING

When inspecting by running the vehicle, note a surrounding traffic situation enough in the place of safety.

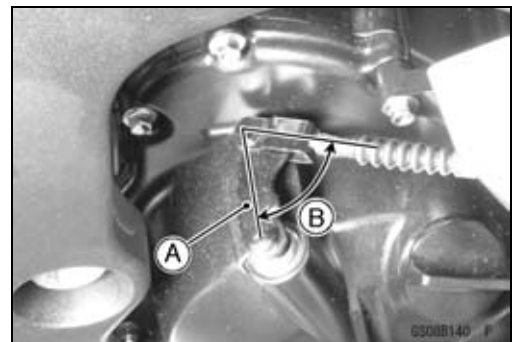
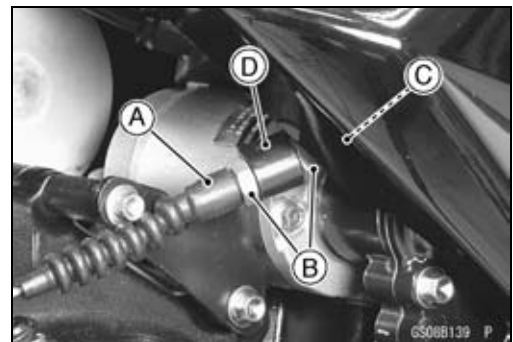



**Maintenance Procedure**

**Wheels/Tires**

**Air Pressure Inspection**

- Remove the air valve cap.
- Measure the tire air pressure with an air pressure gauge [A] when the tires are cold (that is, when the motorcycle has not been ridden more than a mile during the past 3 hours).
- ★ Adjust the tire air pressure according to the specifications if necessary.

**Air Pressure (when Cold)**

- Front: Up to 180 kg (397 lb)**  
**250 kPa (2.5 kgf/cm<sup>2</sup>, 36 psi)**
- Rear: Up to 180 kg (397 lb)**  
**290 kPa (2.9 kgf/cm<sup>2</sup>, 42 psi)**

- Install the air valve cap.

**Wheel/Tire Damage Inspection**

- Remove any imbedded stones [A], nail [B] or other foreign particles from tread.
- Visually inspect the tire for cracks and cuts, and replace the tire if necessary. Swelling or high spots indicate internal damage, requiring tire replacement.
- Visually inspect the wheel for cracks, cuts and dents damage.
- ★ If any damage is found, replace the wheel if necessary.

**Tire Tread Wear Inspection**

As the tire tread wears down, the tire becomes more susceptible to puncture and failure. An accepted estimate is that 90% of all tire failures occur during the last 10% of tread life (90% worn). So it is false economy and unsafe to use the tires until they are bald.

- Measure the tread depth at the center of the tread with a depth gauge [A]. Since the tire may wear unevenly, take measurement at several places.
- ★ If any measurement is less than the service limit, replace the tire (see Tire Removal/Installation in the Wheels/Tires chapter).

**Tread Depth**

**Standard:**

- Front 3.6 mm (0.14 in.)**
- Rear 4.8 mm (0.19 in.)**

**Service Limit:**

- Front 1 mm (0.04 in.)**  
**(AT, CH, DE) 1.6 mm (0.06 in.)**
- Rear 2 mm (0.08 in.) (Up to 130 km/h (80 mph))**  
**3 mm (0.12 in.) (Over 130 km/h (80 mph))**

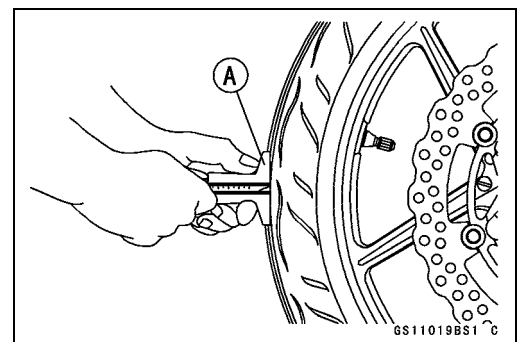
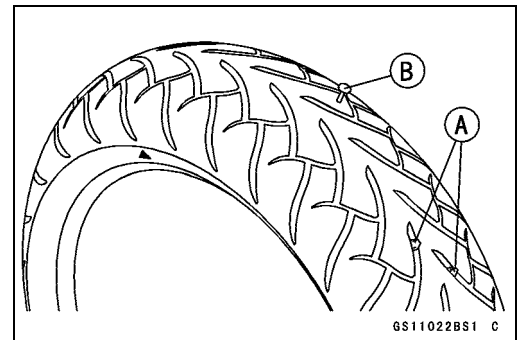
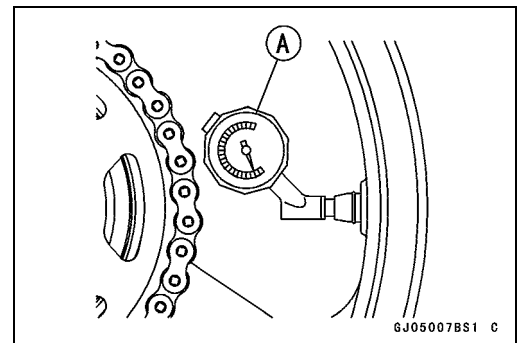

## 2-28 PERIODIC MAINTENANCE

### Maintenance Procedure

#### **⚠ WARNING**

To ensure safe handling and stability, use only the recommended standard tires for replacement, inflated to the standard pressure.

#### **NOTE**

- Most countries may have their own regulations a minimum tire tread depth: be sure to follow them.
- Check and balance the wheel when a tire is replaced with a new one.

#### **Wheel Bearing Damage Inspection**

- Using a jack and attachment, raise the front wheel off the ground (see Front Wheel Removal in the Wheels/Tires chapter).
  - Turn the handlebar all the way to the right or left.
  - Inspect the roughness of the front wheel bearing by moving [A] the wheel to the both side.
  - Spin [B] the front wheel lightly, and check for smoothly turn, roughness, binding or noise.
  - ★ If roughness, binding or noise is found, remove the front wheel and inspect the wheel bearing (see Front Wheel Removal, Hub Bearing Inspection in the Wheels/Tires chapter).
- 
- Using a stand, raise the rear wheel off the ground (see Rear Wheel Removal in the Wheels/Tires chapter).
  - Inspect the roughness of the rear wheel bearing by moving [A] the wheel to the both side.
  - Spin [B] the rear wheel lightly, and check for smoothly turn, roughness, binding or noise.
  - ★ If roughness, binding or noise is found, remove the rear wheel and inspect the wheel bearing (see Rear Wheel Removal, Hub Bearing Inspection in the Wheels/Tires chapter) and coupling (see Coupling Bearing Inspection in the Final Drive chapter).

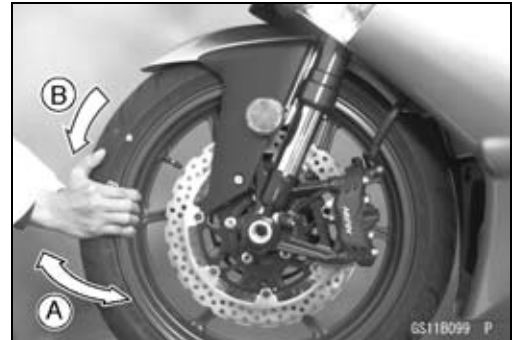

**Maintenance Procedure**

**Final Drive**

**Drive Chain Lubrication Condition Inspection**

- If a special lubricant is not available, a heavy oil such as SAE 90 is preferred to a lighter oil because it will stay on the chain longer and provide better lubrication.
- If the chain appears especially dirty, clean it before lubrication.

**CAUTION**

The O-rings between the side plates seal in the lubricant between the pin and the bushing. To avoid damaging the O-rings and resultant loss of lubricant, observe the following rules.

Use only kerosene or diesel oil for cleaning of the O-ring of the drive chain.

Any other cleaning solution such as gasoline or trichloroethylene will cause deterioration and swelling of the O-ring.

Immediately blow the chain dry with compressed air after cleaning.

Complete cleaning and drying the chain within 10 minutes.

- Apply oil to the sides of the rollers so that oil will penetrate to the rollers and bushings. Apply the oil to the O-rings so that the O-rings will be coated with oil.
- Wipe off any excess oil.
  - Oil Applied Areas [A]
  - O-ring [B]

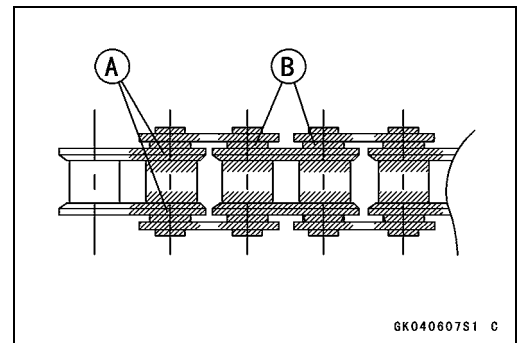

**Drive Chain Slack Inspection**

**NOTE**

- Check the slack with the motorcycle setting on its side stand.
- Clean the chain if it is dirty, and lubricate it if it appears dry.
- Check the wheel alignment (see Wheel Alignment Inspection).
- Rotate the rear wheel to find the position where the chain is tightest.
- Measure the vertical movement (chain slack) [A] midway between the sprockets.
- ★ If the chain slack exceeds the standard, adjust it.

**Chain Slack**

Standard: 30 ~ 40 mm (1.2 ~ 1.6 in.)

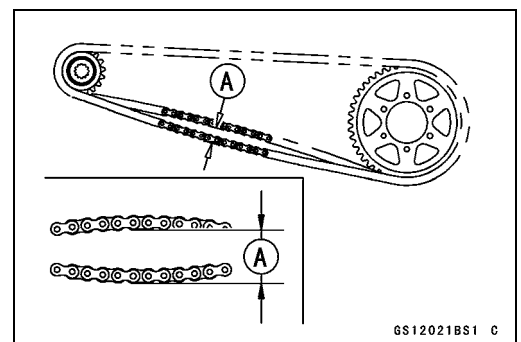

## 2-30 PERIODIC MAINTENANCE

### Maintenance Procedure

#### Drive Chain Slack Adjustment

- Remove the cotter pin [A], and loosen the axle nut [B].
- Loosen the both chain adjuster locknuts [C].
- ★ If the chain is too loose, turn out the left and right chain adjuster [D] evenly.
- ★ If the chain is too tight, turn in the left and right chain adjusters evenly, and kick the wheel forward.
- Turn both chain adjusters evenly until the drive chain has the correct amount of slack. To keep the chain and wheel properly aligned, the notch [E] on the left wheel alignment indicator [F] should align with the same swingarm mark or position [G] that the right indicator notch aligns with.

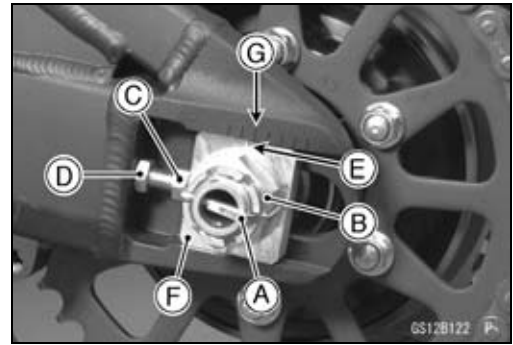

#### **⚠ WARNING**

**Misalignment of the wheel will result in abnormal wear and may result in an unsafe riding condition.**

- Tighten both chain adjuster locknuts securely.
- Tighten the axle nut.
- **Torque - Rear Axle Nut: 127 N·m (13 kgf·m, 94 ft·lb)**
- Turn the wheel, measure the chain slack again at the tightest position, and readjust if necessary.
- Insert a new cotter pin into the axle and bend its end securely.
- Insert a new cotter pin [A].

#### **NOTE**

- When inserting the cotter pin, if the slots in the nut do not align with the cotter pin hole in the axle, tighten the nut clockwise [B] up to next alignment.
- It should be within 30 degree.
- Loosen once and tighten again when the slot goes past the nearest hole.

- Bend the cotter pin [A] over the nut.

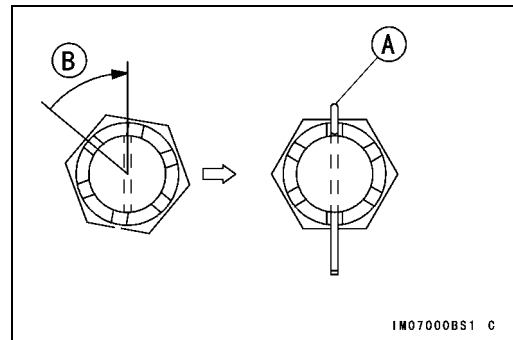

IM07000BS1 C

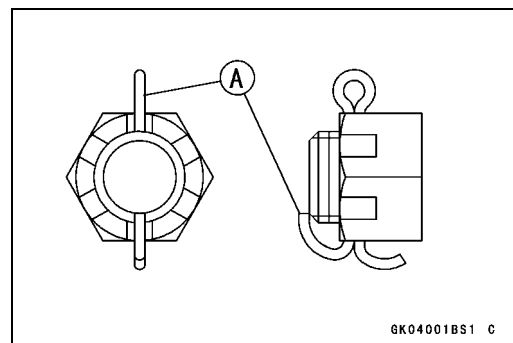

GK04001BS1 C

**Maintenance Procedure**

**Wheel Alignment Inspection**

- Check that the notch [A] on the left alignment indicator [B] aligns with the same swingarm mark or position [C] that the right alignment indicator notch aligns with.
- ★ If they do not, adjust the chain slack and align the wheel alignment (see Drive Chain Slack Adjustment).

**NOTE**

○ Wheel alignment can be also checked using the straightedge or string method.

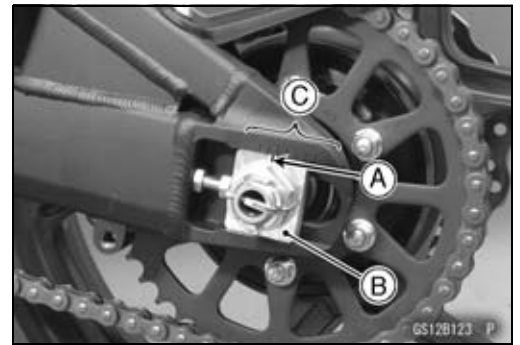

**⚠ WARNING**

**Misalignment of the wheel will result in abnormal wear, and may result in an unsafe riding condition.**

**Drive Chain Wear Inspection**

- Remove:
  - Chain Cover (see Drive Chain Removal in the Final Drive chapter)
- Rotate the rear wheel to inspect the drive chain for damaged rollers, and loose pins and links.
- ★ If there is any irregularity, replace the drive chain.
- ★ Lubricate the drive chain if it appears dry.
- Stretch the chain taut by hanging a 98 N (10 kg, 20 lb) weight [A] on the chain.
- Measure the length of 20 links [B] on the straight part [C] of the chain from the pin center of the 1st pin to the pin center of the 21st pin. Since the chain may wear unevenly, take measurements at several places.
- ★ If any measurements exceed the service limit, replace the chain. Also, replace the front and rear sprockets when the drive chain is replaced.

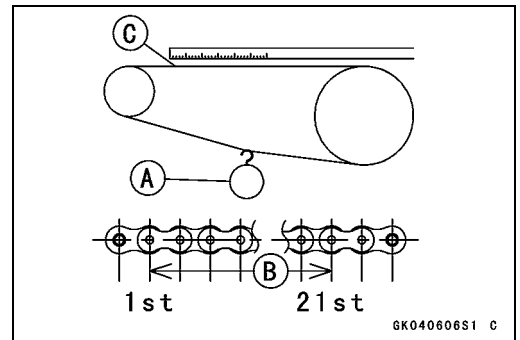

**Drive Chain 20-link Length**

**Standard:** 317.5 ~ 318.2 mm (12.50 ~ 12.53 in.)

**Service Limit:** 323 mm (12.7 in.)

**⚠ WARNING**

**If the drive chain wear exceeds the service limit, replace the chain or an unsafe riding condition may result. A chain that breaks or jumps off the sprockets could snag on the engine sprocket or lock the rear wheel, severely damaging the motorcycle and causing it to go out of control.**

**For safety, use only the standard chain. It is an endless type and should not be cut for installation.**

**Standard Chain**

**Make:** ENUMA

**Type:** EK520MVXL1

**Link:** 112 links

## 2-32 PERIODIC MAINTENANCE

### Maintenance Procedure

#### Chain Guide Wear Inspection

- Remove:
  - Swingarm (see Swingarm Removal in the Suspension chapter)
- Visually inspect the chain guide [A].
- ★ Replace the chain guide if it shows any signs of abnormal wear or damage.



#### Brakes

#### Brake Fluid Leak (Brake Hose and Pipe) Inspection

- Apply the brake lever or pedal and inspect the brake fluid leak from the brake hoses [A] and fittings.
- ★ If the brake fluid leaked from any position, inspect or replace the problem part.

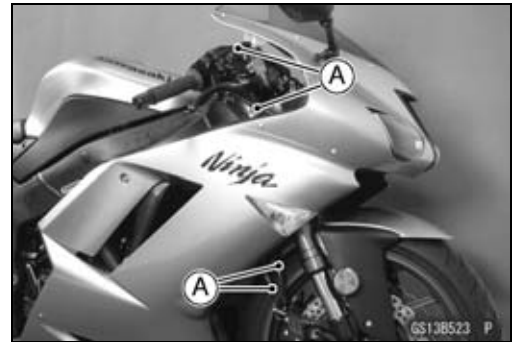

#### Brake Hose Damage and Installation Condition Inspection

- Inspect the brake hoses and fittings for deterioration, cracks and signs of leakage.
- The high pressure inside the brake line can cause fluid to leak [A] or the hose to burst if the line is not properly maintained. Bend and twist the rubber hose while examining it.
- ★ Replace the hose if any crack [B], bulge [C] or leakage is noticed.
- ★ Tighten any brake hose banjo bolts.

**Torque - Brake Hose Banjo Bolts: 25 N·m (2.5 kgf·m, 18 ft·lb)**

- Inspect the brake hose routing.
- ★ If any brake hose routing is incorrect, route the brake hose according to Cable, Wire, and Hose Routing section in the Appendix chapter.

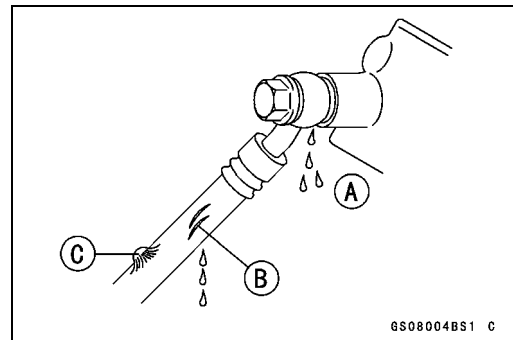

**Maintenance Procedure**

**Brake Operation Inspection**

- Inspect the operation of the front and rear brake by running the vehicle on the dry road.
- ★ If the brake operation is insufficiency, inspect the brake system.

**⚠ WARNING**  
 When inspecting by running the vehicle, note a surrounding traffic situation enough in the place of safety.

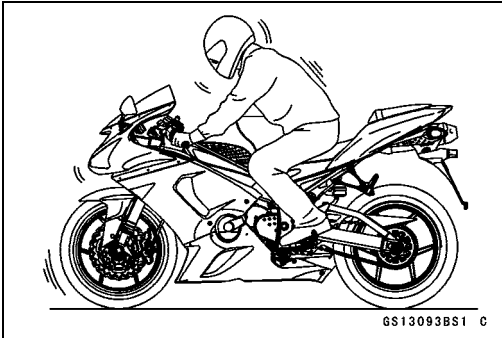

**Brake Fluid Level Inspection**

- Check that the brake fluid level in the front brake reservoir [A] is above the lower level line [B].

**NOTE**

○ Hold the reservoir horizontal by turning the handlebar when checking brake fluid level.

- ★ If the fluid level is lower than the lower level line, fill the reservoir to the upper level line [C].

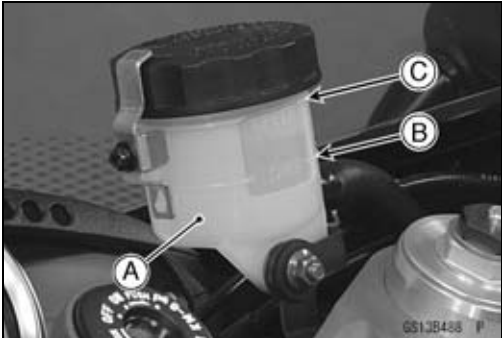

- Check that the brake fluid level in the rear brake reservoir [A] is above the lower level [B].

- ★ If the fluid level is lower than the lower level line, fill the reservoir to the upper level line [C].

**⚠ WARNING**  
 Change the brake fluid in the brake line completely if the brake fluid must be refilled but the type and brand of the brake fluid that is already in the reservoir are unidentified. After changing the fluid, use only the same type and brand of fluid thereafter.

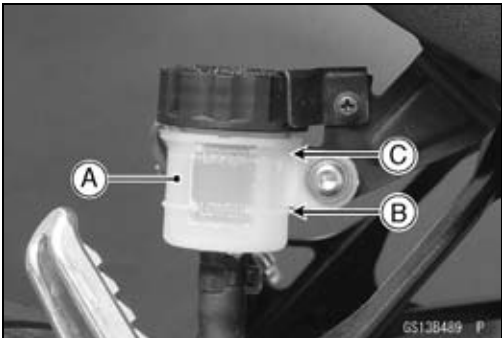

**Recommended Disc Brake Fluid**

Grade: DOT4

- Follow the procedure below to install the front/rear brake fluid reservoir cap correctly.
- First, tighten the brake fluid reservoir cap [B] clockwise [C] by hand until slight resistance is felt indicating that the cap is seated on the reservoir body, then tighten the cap an additional 1/6 turn [D] while holding the brake fluid reservoir body [A].

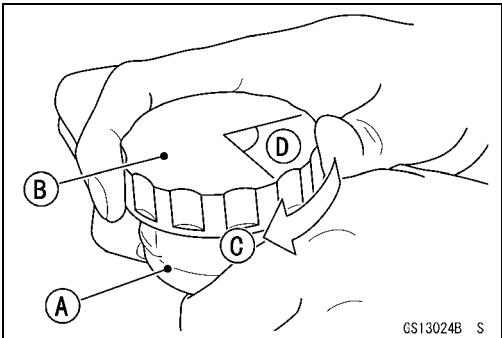

## 2-34 PERIODIC MAINTENANCE

### Maintenance Procedure

#### Brake Pad Wear Inspection

- Check the lining thickness of the pads in each caliper.

##### Pad Lining Thickness

Standard:

Front [A]                    4.0 mm (0.16 in.)

Rear [B]                    5.0 mm (0.20 in.)

Service Limit [C]:    1 mm (0.04 in.)

- ★ If the lining thickness of either pad is less than the service limit, replace both pads in the caliper as a set.

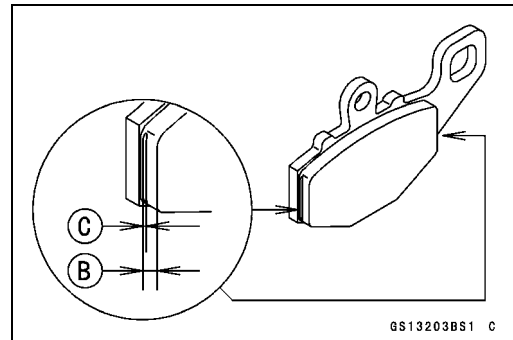
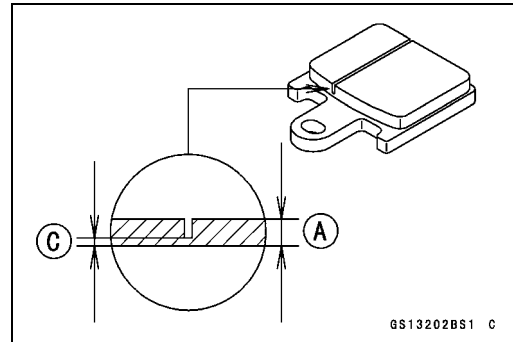

#### Brake Light Switch Operation Inspection

- Turn on the ignition switch.
- The brake light [A] should go on when the brake lever is applied or after the brake pedal is depressed about 10 mm (0.39 in.).



- ★ If it does not, adjust the brake light switch.
- While holding the switch body, turn the adjusting nut to adjust the switch.
  - Switch Body [A]
  - Adjusting Nut [B]
  - Light sooner as the body rises [C]
  - Light later as the body lowers [D]

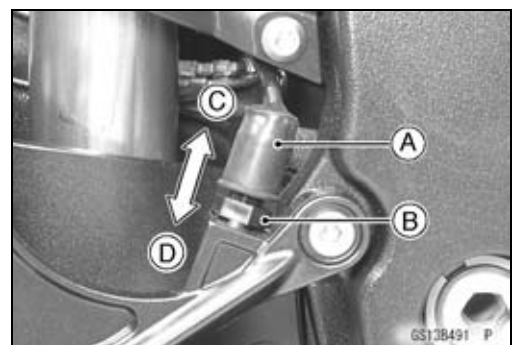

#### CAUTION

To avoid damaging the electrical connections inside the switch, be sure that the switch body does not turn during adjustment.



## Maintenance Procedure

- ★ If it does not go on, inspect or replace the following items.
  - Battery (see Charging Condition Inspection in the Electrical System chapter)
  - Brake Light (see Tail/Brake Light Removal in the Electrical System chapter)
  - Main Fuse 30 A and Taillight Fuse 10 A (see Fuse Inspection in the Electrical System chapter)
  - Front Brake Light Switch [A] (see Switch Inspection in the Electrical System chapter)
  - Rear Brake Light Switch (see Switch Inspection in the Electrical System chapter)
  - Harness (see Wiring Inspection in the Electrical System chapter)

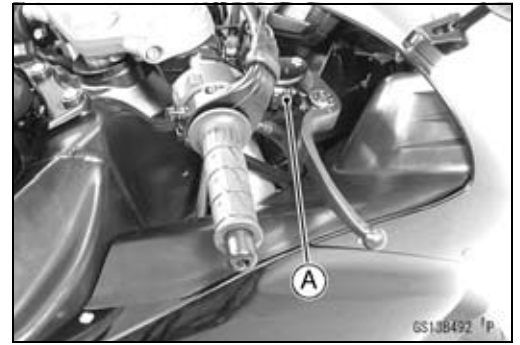

## Suspensions

### Front Forks/Rear Shock Absorber Operation Inspection

- Pump the forks down and up [A] 4 or 5 times, and inspect the smooth stroke.
- ★ If the forks do not smoothly or noise is found, inspect the fork oil level or fork clamps (see Front Fork Oil Change in the Suspension chapter).



- Pump the seat down and up [A] 4 or 5 times, and inspect the smooth stroke.
- ★ If the shock absorber does not smoothly stroke or noise is found, inspect the oil leak or shock absorber clamps (see Rear Shock Absorber Oil Leak Inspection in this chapter).



### Front Fork Oil Leak Inspection

- Visually inspect the front forks [A] for oil leakage.
- ★ Replace or repair any defective parts, if necessary.

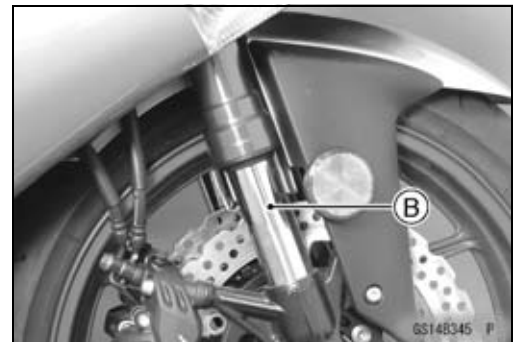

## 2-36 PERIODIC MAINTENANCE

### Maintenance Procedure

#### **Rear Shock Absorber Oil Leak Inspection**

- Visually inspect the shock absorber [A] for oil leakage.
- ★ If the oil leakage is found on it, replace the shock absorber with a new one.

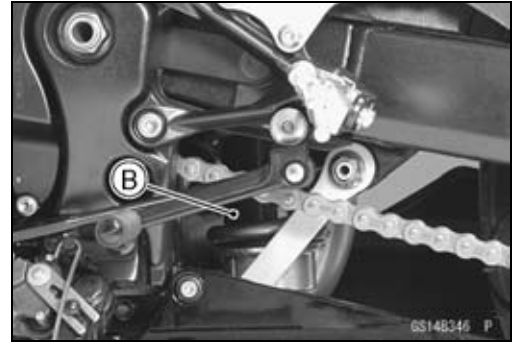

#### **Rocker Arm Operation Inspection**

- Pump the seat down and up 4 or 5 times, and inspect the smooth stroke.
- ★ If the rocker arm [A] does not smoothly stroke or noise is found, inspect the fasteners and bearings (see Rocker Arm/Tie-Rod Bearing, Sleeve Inspection in the Suspension chapter).

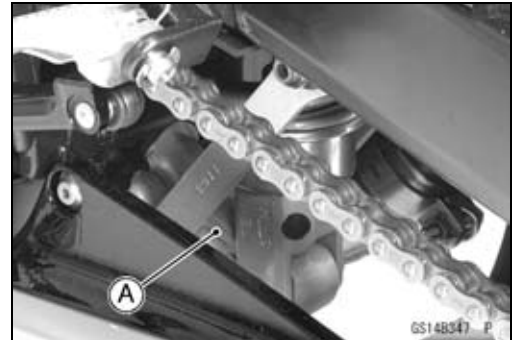

#### **Tie-Rod Operation Inspection**

- Pump the seat down and up 4 or 5 times, and inspect the smooth stroke.
- ★ If the tie-rods [A] do not smoothly stroke or noise is found, inspect the fasteners and tie-rod bearings (see Rocker Arm/Tie-Rod Bearing, Sleeve Inspection in the Suspension chapter).



### Steering System

#### **Steering Play Inspection**

- Remove the lower fairings (see Lower Fairing Removal in the Frame chapter).
- Lift the front wheel off the ground using the jack.

**Special Tools - Jack: 57001-1238**

**Jack Attachment: 57001-1608**

- With the front wheel pointing straight ahead, alternately tap each end of the handlebar. The front wheel should swing fully left and right from the force of gravity until the fork hits the stop.
- ★ If the wheel binds or catches before the stop, the steering is too tight.
- Feel for steering looseness by pushing and pulling the forks.
- ★ If you feel looseness, the steering is too loose.



#### **NOTE**

- The cables and wiring will have some effect on the motion of the fork which must be taken into account.
- Be sure the wires and cables are properly routed.
- The bearings must be in good condition and properly lubricated in order for any test to be valid.

**Maintenance Procedure**

**Steering Play Adjustment**

- Raise the front wheel off the ground with the jack.
- Remove:
  - Upper End of Clutch Cable
  - Upper End of Throttle Cables
  - Stem Head Nut [A] and Washer [B]
  - Handlebar Position Bolts [C]
- Loosen the upper fork clamp bolts [D].
- Remove the stem head [E].

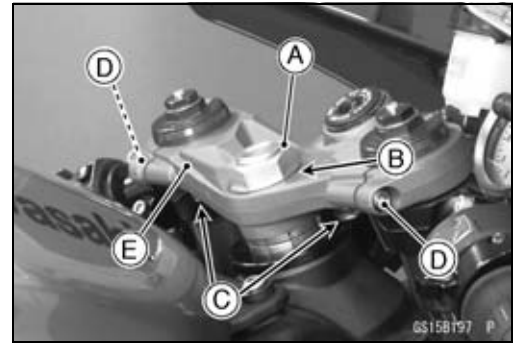

- Bend the claws [A] of the claw washer straighten.
- Remove the steering stem locknut [B] and claw washer [C].

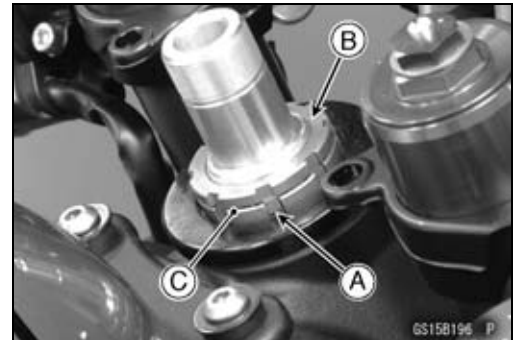

- Adjust the steering.

**Special Tool - Steering Stem Nut Wrench [A]: 57001-1100**

- ★ If the steering is too tight, loosen the stem nut a fraction of a turn.
- ★ If the steering is too loose, tighten the stem nut a fraction of a turn.

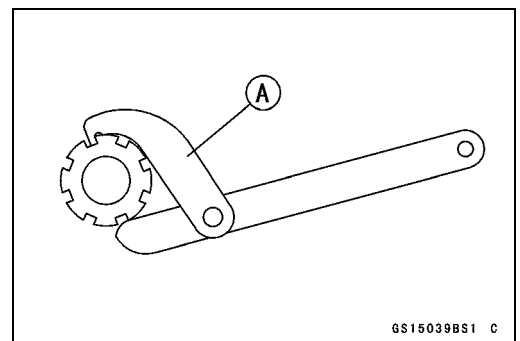

**NOTE**

○ Turn the stem nut 1/8 turn at time maximum.

- Install the claw washer [A] so that its bent side [B] faces upward, and engage the bent claws with the grooves of stem locknut [C].
- Hand tighten the stem locknut until it touches the claw washer.
- Tighten the stem locknut clockwise until the claws are aligned with the grooves (ranging from 2nd to 4th) of stem nut [D], and bend the 2 claws downward [E].

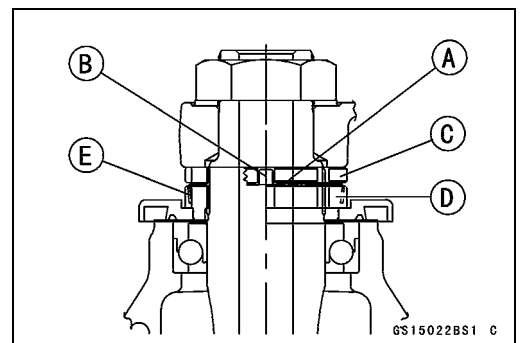

- Apply a non-permanent locking agent to the handlebar position bolts.
- Tighten:

**Torque - Steering Stem Head Nut: 78 N·m (8.0 kgf·m, 58 ft·lb)**  
**Upper Front Fork Clamp Bolts: 20 N·m (2.0 kgf·m, 15 ft·lb)**  
**Handlebar Position Bolts: 9.8 N·m (1.0 kgf·m, 87 in·lb)**

- Check the steering again.
- ★ If the steering is still too tight or too loose, repeat the adjustment.

## 2-38 PERIODIC MAINTENANCE

### Maintenance Procedure

#### Steering Stem Bearing Lubrication

- Remove the steering stem (see Stem, Stem Bearing Removal in the Steering chapter).
- Using a high-flash point solvent, wash the upper and lower ball bearings in the cages, and wipe the upper and lower outer races, which are press-fitted into the frame head pipe, clean off grease and dirt.
- Visually check the outer races and the ball bearings.
- ★ Replace the bearing assemblies if they show wear or damage.
- Pack the upper and lower ball bearings [A] in the cages with grease, and apply a light coat of grease to the upper and lower outer races.
- Install the steering stem (see Stem, Stem Bearing Installation in the Steering chapter).
- Adjust the steering (see Steering Play Adjustment in this chapter).

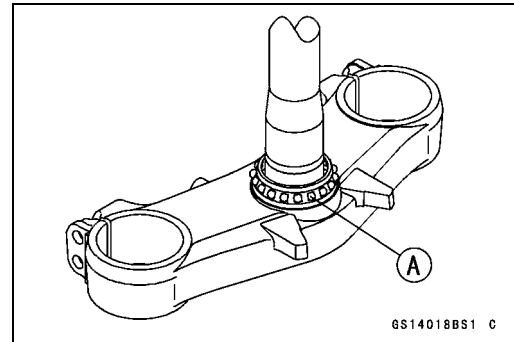

#### Lights and Switches Operation Inspection

##### First Step

- Turn on the ignition switch.
- The following lights should go on according to below table.

City Light [A]	goes on
Taillight (LED) [B]	goes on
License Plate Light [C]	goes on
Meter Panel LCD [D]	goes on
Neutral Indicator Light (LED) [E]	goes on
Warning Indicator Light (LED) [F]	goes on (blinks)
Meter Panel Illumination Light (LED) [G]	goes on

- ★ If the light does not go on, inspect or replace the following item.

Battery (see Charging Condition Inspection in the Electrical System chapter)

Applicable Bulbs (see Wiring Diagram in the Electrical System chapter)

Meter Unit (see Electronic Combination Meter Unit Inspection in the Electrical System chapter)

ECU (see ECU Power Supply Inspection in the Fuel System (DFI) chapter)

Main Fuse 30 A and Taillight Fuse 10 A (see Fuse Inspection in the Electrical System chapter)

Ignition Switch (see Wiring Diagram in the Electrical System chapter)

Gear Position Switch (see Gear Position Switch Inspection in the Electrical System chapter)

Harness (see Wiring Inspection in the Electrical System chapter)

- Turn off the ignition switch.
- The all lights should go off (for the immobilizer model, warning indicator light (LED) will blink. see Abstract in the Electrical System chapter).
- ★ If the light does not go off, replace the ignition switch.

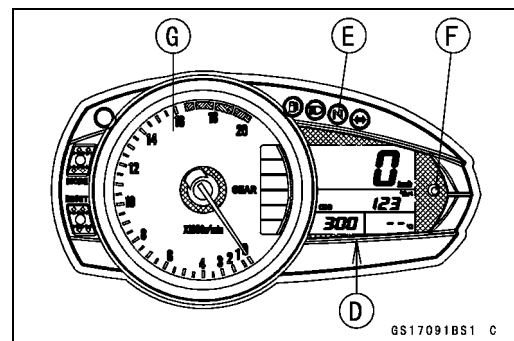
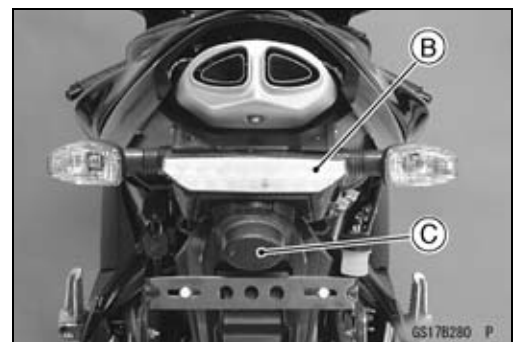

## Maintenance Procedure

### Second Step

- Turn the ignition switch to P (Park) position.
- The city light, tail/brake light (LED) and license plate light should go on.
- ★ If the light does not go on, inspect or replace the following item.
  - Ignition Switch (see Wiring Diagram in the Electrical System chapter)

### Third Step

- Turn on the ignition switch.
- Push the turn signal switch [A] (left or right position).
- The left or right turn signal lights [B] (front and rear) according to the switch position should blink.
- The turn signal indicator light (LED) [C] in the meter unit should blink.
- ★ If the each light does not blink, inspect or replace the following item.
  - Turn Signal Light Bulb (see Turn Signal Light Bulb Replacement in the Electrical System chapter)
  - Meter Unit for Turn Signal Light Indicator Light (LED) (see Electronic Combination Meter Unit Inspection in the Electrical System chapter)
  - Turn Signal Relay Fuse 10 A (see Fuse Inspection in the Electrical System chapter)
  - Turn Signal Switch (see Wiring Diagram in the Electrical System chapter)
  - Turn Signal Relay (see Turn Signal Relay Inspection in the Electrical System chapter)
  - Harness (see Wiring Inspection in the Electrical System chapter)
- Put back the turn signal switch.
- The turn signal lights and indicator light (LED) should go off.
- ★ If the light does not go off, inspect or replace the following item.
  - Turn Signal Switch (see Wiring Diagram in the Electrical System chapter)

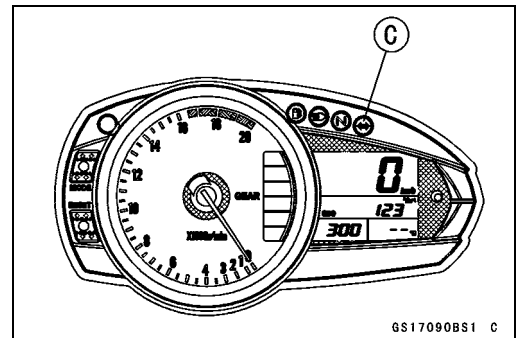
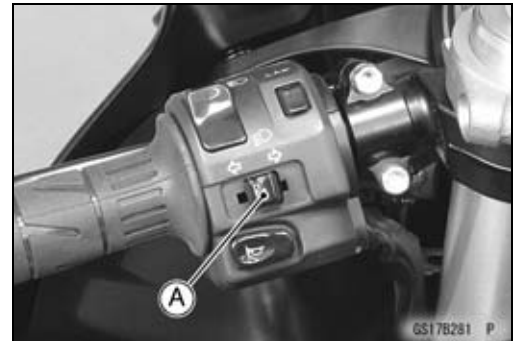

### Fourth Step

- Set the dimmer switch [A] to low beam position.
- Start the engine.
- The low beam headlight should go on.
- ★ If the low beam headlight does not go on, inspect or replace the following item.
  - Headlight Low Beam Bulb (see Headlight Bulb Replacement in the Electrical System chapter)
  - Headlight Fuse 10 A (see Fuse Inspection in the Electrical System chapter)
  - Dimmer Switch (see Wiring Diagram in the Electrical System chapter)
  - Headlight Relay (see Relay Circuit Inspection in the Electrical System chapter)
  - Harness (see Wiring Inspection in the Electrical System chapter)

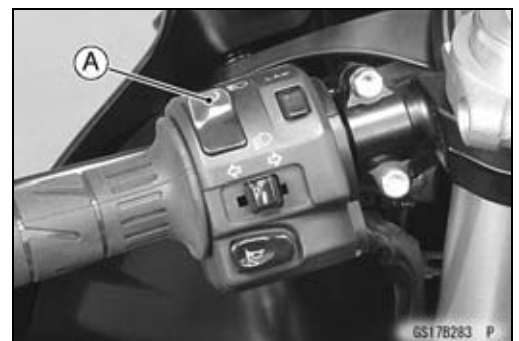

## 2-40 PERIODIC MAINTENANCE

### Maintenance Procedure

- Set the dimmer switch to high beam position.
- The low beam [A] and high beam [B] headlights should go on.
- The high beam indicator light (LED) [C] should go on.
- ★ If the high beam headlight and/or high beam indicator light (LED) does not go on, inspect or replace the following item.
  - Headlight High Beam Bulb (see Headlight Bulb Replacement in the Electrical System chapter)
  - Dimmer Switch (see Wiring Diagram in the Electrical System chapter)
  - Harness (see Wiring Inspection in the Electrical System chapter)
  - Headlight Fuse 10 A (see Fuse Inspection in the Electrical System chapter)
  - Headlight Relay (see Relay Circuit Inspection in the Electrical System chapter)
- Turn off the engine stop switch.
- The low beam and high beam headlights should stay going on.
- ★ If the headlights and high beam indicator light (LED) does go off, inspect or replace the following item.
  - Headlight Relay (see Relay Circuit Inspection in the Electrical System chapter)
- Turn off the ignition switch.
- The headlights and high beam indicator light (LED) should go off.

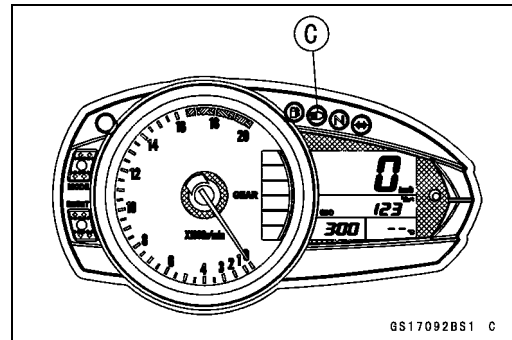
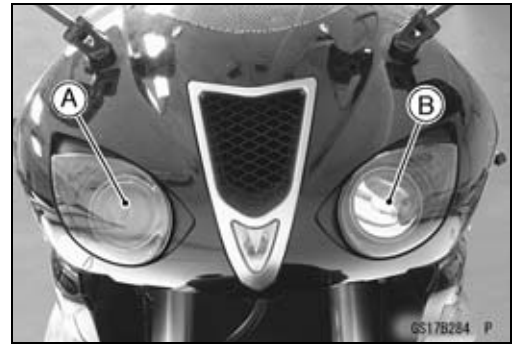

### Headlight Aiming Inspection

- Inspect the headlight beam for aiming.
- ★ If the headlight beam points to one side rather than straight ahead, adjust the horizontal beam.

### Headlight Beam Horizontal Adjustment

- Turn the horizontal adjuster [A] in both headlights in or out until the beam points straight ahead.
- ★ If the headlight beam points too low or high, adjust the vertical beam.

### Headlight Beam Vertical Adjustment

- Turn the vertical adjuster [B] in both headlights in or out with a screwdriver to adjust the headlight vertically.

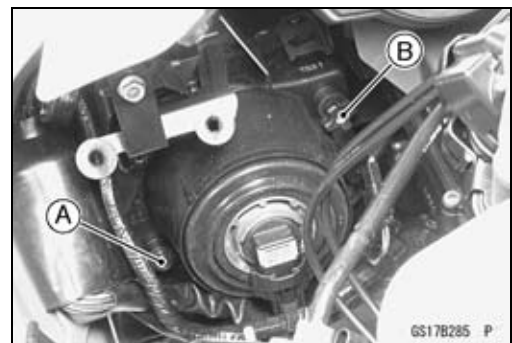

### NOTE

- ON high beam, the brightest points should be slightly below horizontal with the motorcycle on its wheels and the rider seated. Adjust the headlight to the proper angle according to local regulations.

**Maintenance Procedure**

**NOTE**

○ For US model, the proper angle is 0.4 degrees below horizontal. This is 50 mm (2 in.) drop at 7.6 m (25 ft) measured from the center of the headlight with the motorcycle on its wheels and the rider seated.

50 mm (2 in.) [A]

Center of Brightest Spot [B]

7.6 m (25 ft) [C]

Height of Headlight Center [D]

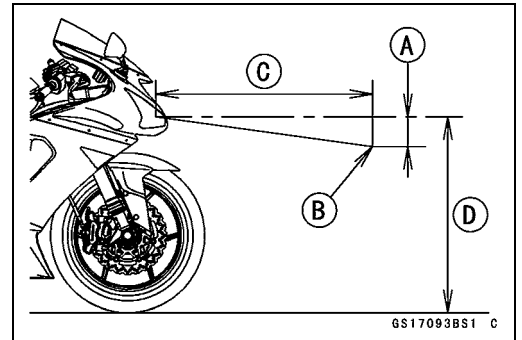

**Side Stand Switch Operation Inspection**

● Inspect the side stand switch [A] operation accordance to below table.

**Side Stand Switch Operation**

Side Stand	Gear Position	Clutch Lever	Engine Start	Engine Run
Up	Neutral	Released	Starts	Continue running
Up	Neutral	Pulled in	Starts	Continue running
Up	In Gear	Released	Doesn't start	Continue running
Up	In Gear	Pulled in	Starts	Continue running
Down	Neutral	Released	Starts	Continue running
Down	Neutral	Pulled in	Starts	Continue running
Down	In Gear	Released	Doesn't start	Stops
Down	In Gear	Pulled in	Doesn't start	Stops

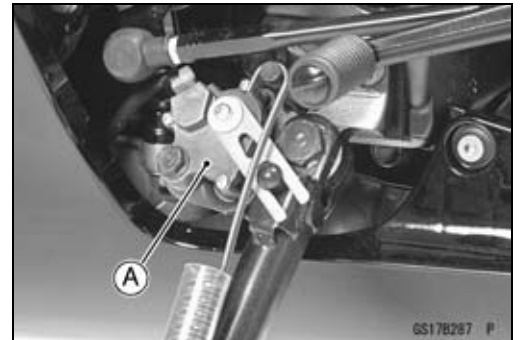

## 2-42 PERIODIC MAINTENANCE

### Maintenance Procedure

★ If the side stand switch operation does not work, inspect or replace the following item.

Battery (see Charging Condition Inspection in the Electrical System chapter)

Main Fuse 30 A (see Fuse Inspection in the Electrical System chapter)

Ignition Fuse 10 A (see Fuse Inspection in the Electrical System chapter)

Ignition Switch (see Wiring Diagram in the Electrical System chapter)

Side Stand Switch (see Switch Inspection in the Electrical System chapter)

Engine Stop Switch (see Switch Inspection in the Electrical System chapter)

Starter Button (see Wiring Diagram in the Electrical System chapter)

Gear Position Switch (see Gear Position Switch Inspection in the Electrical System chapter)

Starter Relay (see Starter Relay Inspection in the Electrical System chapter)

Starter Circuit Relay (see Relay Circuit Inspection in the Electrical System chapter)

Harness (see Wiring Inspection in the Electrical System chapter)

★ If all parts are in good condition, replace the ECU.

#### **Engine Stop Switch Operation Inspection**

##### **First Step**

- Turn on the ignition switch.
- Set the neutral position.
- Turn the engine stop switch to stop position [A].
- Push the starter button.
- The engine does not start.

★ If the engine starts, inspect or replace the following item.  
Engine Stop Switch (see Switch Inspection in the Electrical System chapter)

##### **Second Step**

- Turn on the ignition switch.
  - Set the neutral position.
  - Turn the engine stop switch to run position [A].
  - Push the starter button and run the engine.
  - Turn the engine stop switch to stop position.
  - Immediately the engine should stop.
- ★ If the engine does not stop, inspect or replace the following item.

Engine Stop Switch (see Switch Inspection in the Electrical System chapter)

★ If the engine stop switch is in good condition, replace the ECU (see ECU Removal/Installation in the Fuel System (DFI) chapter).





**Maintenance Procedure**

**Others**

**Chassis Parts Lubrication**

- Before lubricating each part, clean off any rusty spots with rust remover and wipe off any grease, oil, dirt, or grime.
- Lubricate the points listed below with indicated lubricant.

**NOTE**

○ *Whenever the vehicle has been operated under wet or rainy conditions, or especially after using a high-pressure water spray, perform the general lubrication.*

**Pivots: Lubricate with Grease.**

- Brake Lever
- Brake Pedal
- Clutch Lever
- Rear Brake Joint Pin
- Side Stand

**Points: Lubricate with Grease.**

- Clutch Inner Cable Upper and Lower Ends [A]
- Throttle Inner Cable Upper End

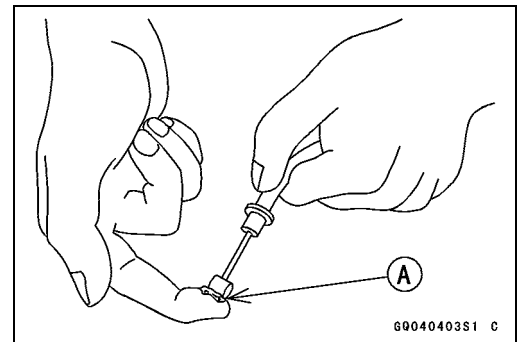

**Cables: Lubricate with Rust Inhibitor**

- Clutch Inner Cable
- Throttle Inner Cables

- Lubricate the cables by seeping the oil between the cable and housing.
- The cable may be lubricated by using a commercially available pressure cable lubricator with an aerosol cable lubricant.

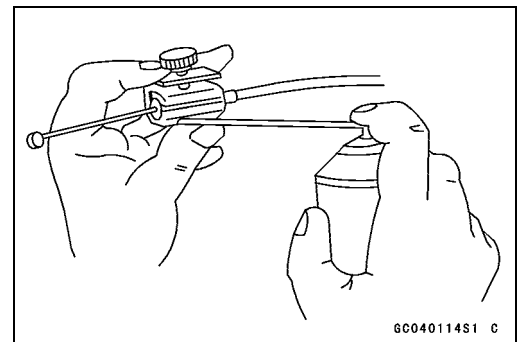

- With the cable disconnected at both ends, the inner cable should move freely [A] within the cable housing.
- ★ If cable movement is not free after lubricating, if the cable is frayed [B], or if the cable housing is kinked [C], replace the cable.

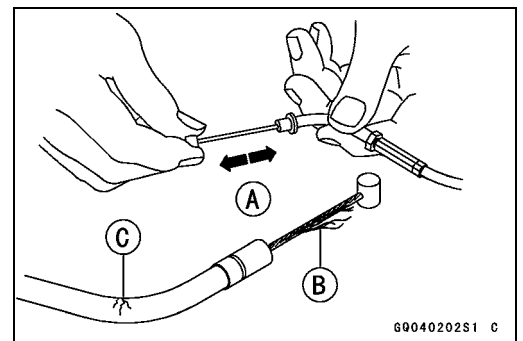

## 2-44 PERIODIC MAINTENANCE

---

### Maintenance Procedure

---

#### ***Bolts, Nuts and Fasteners Tightness Inspection***

- Check the tightness of the bolts and nuts listed here. Also, check to see that each cotter pin is in place and in good condition.

#### **NOTE**

○ *For the engine fasteners, check the tightness of them when the engine is cold (at room temperature).*

- ★ If there are loose fasteners, retorque them to the specified torque following the specified tightening sequence. Refer to the appropriate chapter for torque specifications. If torque specifications are not in the appropriate chapter, see the Standard Torque Table. For each fastener, first loosen it by 1/2 turn, then tighten it.
- ★ If cotter pins are damaged, replace them with new ones.

#### **Bolt, Nut and Fastener to be checked**

##### Engine:

- Clutch Lever Pivot Bolt Locknut
- Engine Mounting Bolts
- Exhaust Pipe Clamp Bolts
- Exhaust Pipe Front Holder Nuts
- Muffler Body Mounting Bolts

##### Wheels:

- Front Axle Clamp Bolts
- Front Axle Nut
- Rear Axle Nut
- Rear Axle Nut Cotter Pin

##### Brakes:

- Brake Lever Pivot Bolt Locknut
- Brake Pedal Bolt
- Rear Master Cylinder Push Rod Joint Cotter Pin
- Caliper Mounting Bolts
- Front Master Cylinder Clamp Bolts
- Rear Master Cylinder Mounting Bolts

##### Suspension:

- Front Fork Clamp Bolts
- Rear Shock Absorber Mounting Nuts
- Swingarm Pivot Shaft Nut
- Uni-Trak Link Nuts

##### Steering:

- Handlebar Bolts
- Steering Stem Head Nut

##### Others:

- Footpeg Bracket Bolts
- Front Fender Mounting Bolts
- Side Stand Bolt

**Maintenance Procedure**

**Replacement Parts**

**Air Cleaner Element Replacement**

**NOTE**

- In dusty areas, the element should be replaced more frequently than the recommended interval.
- After riding through rain or on muddy roads, the element should be replaced immediately.

**⚠ WARNING**

If dirt or dust is allowed to pass through into the throttle body assy, the throttle may become stuck, possibly causing an accident.

**CAUTION**

If dirt gets through into the engine, excessive engine wear and possibly engine damage will occur.

- Remove:  
Front Seat (see Front Seat Removal in the Frame chapter)
- Remove:  
Fuel Tank Bolts [A]



- Remove:  
Hoses [A] (California Model)



- Set up the fuel tank [A] using the suitable tool or bar [B].
- The steering position is straight.

**NOTE**

- Be careful not to drop or damage the fuel tank.

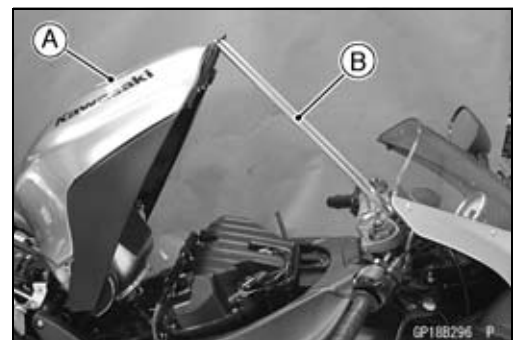

## 2-46 PERIODIC MAINTENANCE

### Maintenance Procedure

- Remove:
  - Inlet Air Temperature Sensor [A]
  - Inlet Air Pressure Sensor [B]

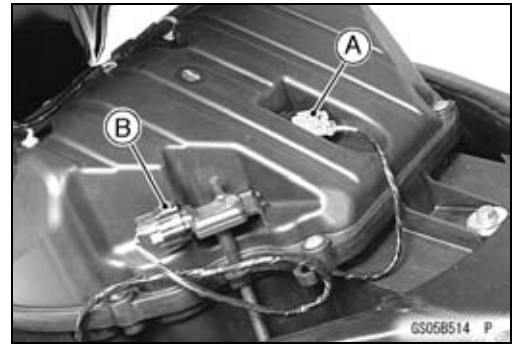

- Remove:
  - Air Cleaner Housing Screws [A]
  - Upper Air Cleaner Housing [B]
- Discard:
  - Air Cleaner Element

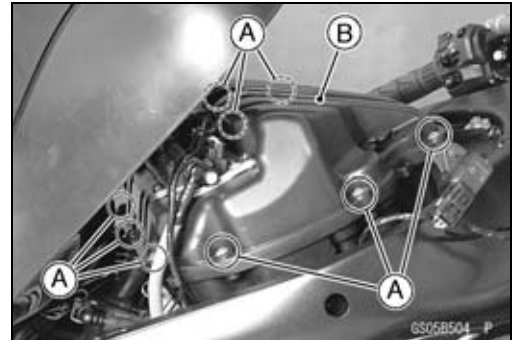

- Install a new element [A].
- Tighten:
  - Torque - Air Cleaner Housing Screws: 1.1 N·m (0.11 kgf·m, 9.7 in·lb)

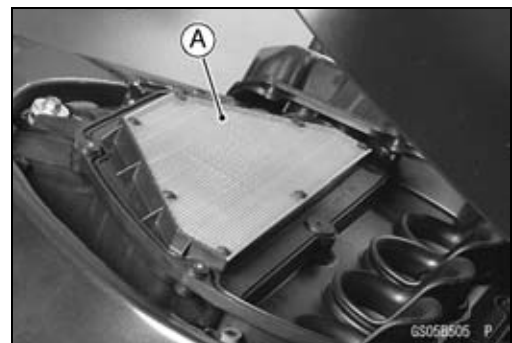

#### CAUTION

Use only the recommended air cleaner element (Kawasaki part number 11013-0016). Using another air cleaner element will wear the engine prematurely or lower the engine performance.

- Install:
  - Hoses (California Model)
  - Inlet Air Temperature Sensor (see Inlet Air Temperature Sensor Installation in the Fuel System (DFI) chapter)
  - Inlet Air Pressure Sensor (see Inlet Air Pressure Sensor Installation in the Fuel System (DFI) chapter)
  - Fuel Tank (see Fuel Tank Installation in the Fuel System (DFI) chapter)

#### **Fuel Hose Replacement**

- Set up the fuel tank (see Air Cleaner Element Replacement).

**Maintenance Procedure**

**For Primary Fuel Hose**

- Be sure to place a piece of cloth [A] around the fuel hose joint [B].
- Insert the (-) screw driver into the slot [C] of the joint lock.

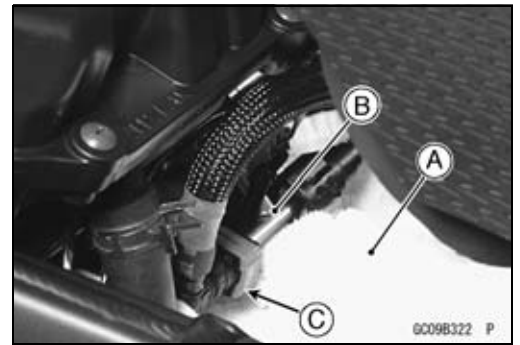

- Pull the joint lock [A] as shown.
- Pull the fuel hose joint [B] out of the delivery pipe.

**⚠ WARNING**  
**Be prepared for fuel spillage; any spilled fuel must be completely wiped up immediately. When the fuel hose is disconnected, fuel spills out from the hose and the pipe. Cover the hose connection with a clean shop towel to prevent fuel spillage.**

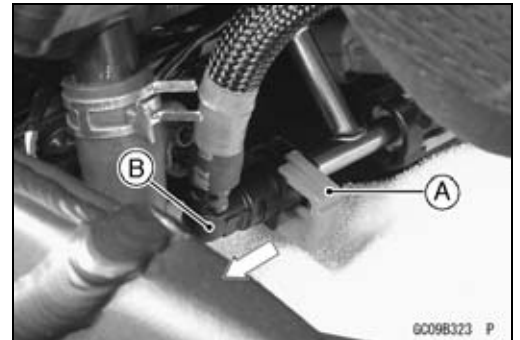

**NOTE**

○ Removing the hose joint of the fuel pump side is the same as for the throttle body assy side.

- Install the new fuel hose.
- Pull [A] the joint lock [B] fully as shown.

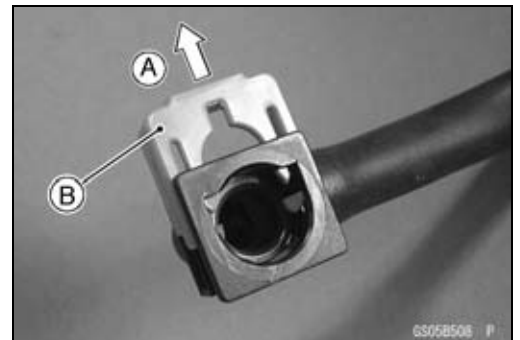

- Insert the fuel hose joint [A] straight onto the delivery pipe until the hose joint clicks.
- Push [B] the joint lock [C] until the hose joint clicks.

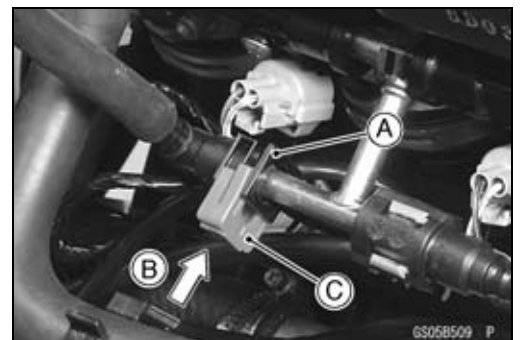

## 2-48 PERIODIC MAINTENANCE

### Maintenance Procedure

#### For Secondary Fuel Hose

- Set up the fuel tank (see Air Cleaner Element Replacement).
- Be sure to place a piece of cloth [A] around the fuel hose joint [B].
- Push the joint lock claws [C].

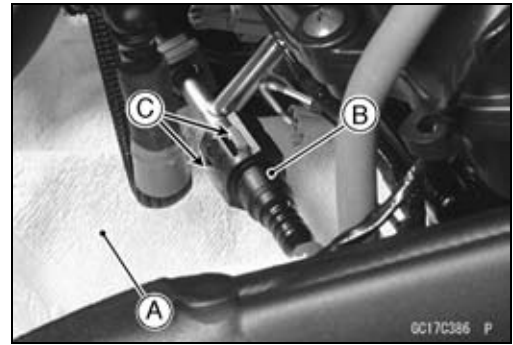

- Pull the joint lock [A] as shown.
- Pull the fuel hose joint [B] out of the delivery pipe [C].

#### **⚠ WARNING**

**Be prepared for fuel spillage; any spilled fuel must be completely wiped up immediately. When the fuel hose is disconnected, fuel spills out from the hose and the pipe because of residual pressure. Cover the hose connection with a piece of clean cloth to prevent fuel spillage.**

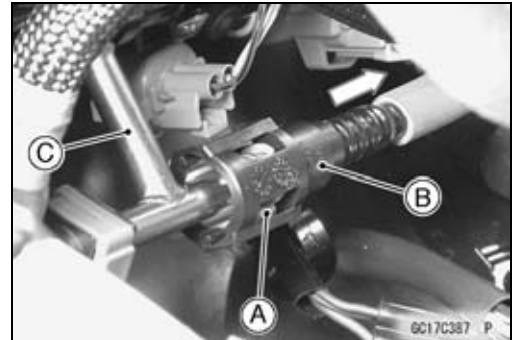

- Remove:
  - Fuel Hose Mounting Screw [A]
  - Fuel Hose [B]

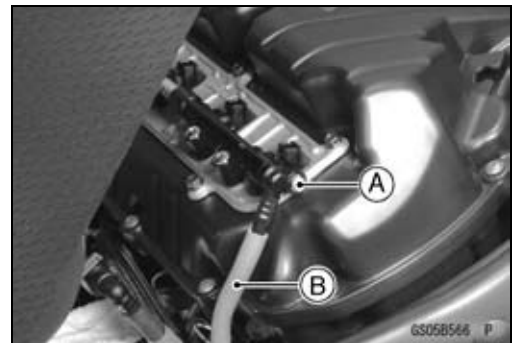

- Apply engine oil to the new O-ring [A].
- Tighten:
  - Torque - Fuel Hose Mounting Screw [B]: 4.9 N-m (0.50 kgf-m, 43 ft-lb)

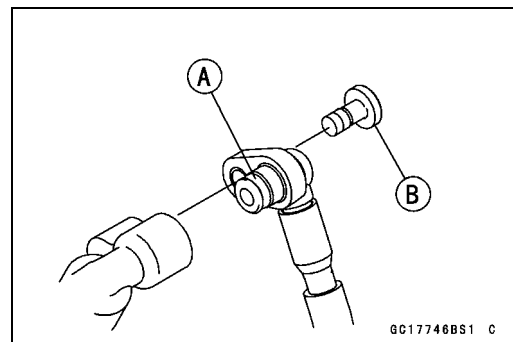

- Insert the fuel hose joint [A] straight onto the delivery pipe until the hose joint clicks.
- Push [B] the joint lock [C] until the hose joint clicks.

#### **⚠ WARNING**

**Make sure the fuel hose joint is installed correctly on the delivery pipe or the fuel could leak.**

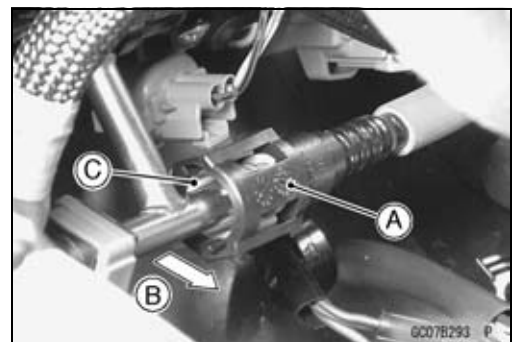

- Run the fuel hose in accordance with the Cable, Wire, and Hose Routing section in the Appendix chapter.
- Install the removed parts (see appropriate chapters).
- Start the engine and check the fuel hose for leaks.

Maintenance Procedure

Coolant Change

**⚠ WARNING**

To avoid burns, do not remove the radiator cap or try to change the coolant when the engine is still hot. Wait until it cools down. Coolant on tires will make them slippery and can cause an accident and injury. Immediately wipe up or wash away any coolant that spills on the frame, engine, or other painted parts. Since coolant is harmful to the human body, do not use for drinking.

- Remove:
  - Right Inner Cover (see Inner Cover Removal in the Frame chapter)
  - Radiator Cap [A]
- Remove the radiator cap in two steps. First turn the cap counterclockwise to the first stop. Then push and turn it further in the same direction and remove the cap.



- Remove:
  - Left Middle Fairing (see Middle Fairing Removal in the Frame chapter)
- Place a containers under the drain bolts [A] [B] of the water pump cover and cylinder.
- Drain the coolant from the radiator and engine by removing the drain bolts.

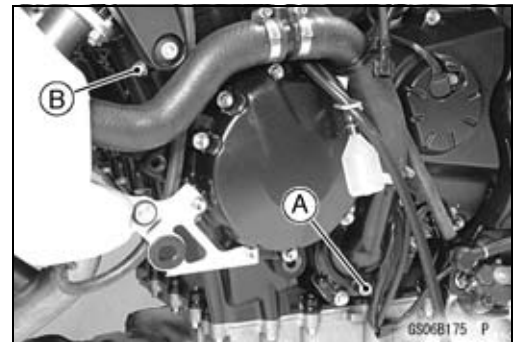

- Remove:
  - Coolant Reserve Tank [A] (see Coolant Reserve Tank Removal in the Cooling System chapter)
- Remove the cap [B] and pour the coolant into a container.

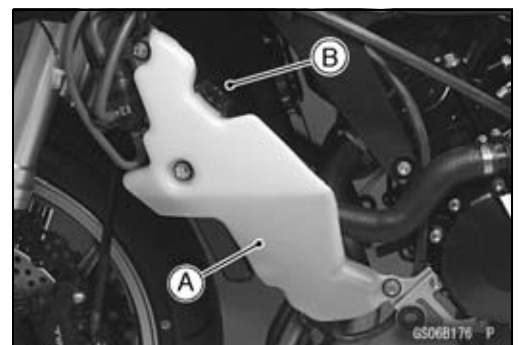

- Install the coolant reserve tank (see Coolant Reserve Tank Installation in the Cooling System chapter).
- Tighten the drain bolts with the washers.
- Replace the drain bolt washers with a new one if it is damaged.

**Torque - Coolant Drain Bolt (Water Pump): 8.8 N·m (0.90 kgf·m, 78 in·lb)**  
**Coolant Drain Bolt (Cylinder): 9.8 N·m (1.0 kgf·m, 87 in·lb)**

## 2-50 PERIODIC MAINTENANCE

### Maintenance Procedure

- Fill the radiator up to the radiator filler neck [A] with coolant, and install the radiator cap.

#### NOTE

- Pour in the coolant slowly so that it can expel the air from the engine and radiator.

- Fill the reserve tank up to the full level line with coolant, and install the cap.

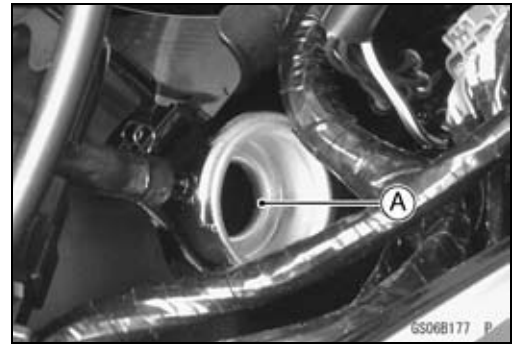

#### CAUTION

**Soft or distilled water must be used with the antifreeze (see below for antifreeze) in the cooling system.**

**If hard water is used in the system, it causes scales accumulation in the water passages, and considerably reduces the efficiency of the cooling system.**

#### Water and Coolant Mixture Ratio (Recommended)

Soft Water:	50%
Coolant:	50%
Freezing Point:	-35°C (-31°F)
Total Amount:	2.6 L (2.7 US qt)

#### NOTE

- Choose a suitable mixture ratio by referring to the coolant manufacturer's directions.

- Bleed the air from the cooling system as follows.
  - Start the engine with the radiator cap removed and run it until no more air bubbles [A] can be seen in the coolant.
  - Tap the radiator hoses to force any air bubbles caught inside.
  - Stop the engine and add coolant up to the radiator filler neck.
- Install the radiator cap.
- Start the engine, warm it up thoroughly until the radiator fan turns on and then stop the engine.
- Check the coolant level in the reserve tank after the engine cools down.
- ★ If the coolant level is lower than the low level line, add coolant to the full level line.

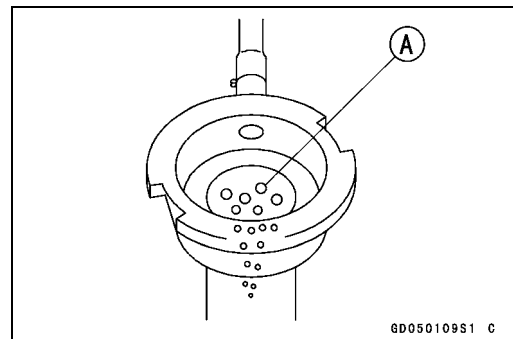

#### CAUTION

**Do not add more coolant above the full level line.**



**Maintenance Procedure**

**Radiator Hose and O-ring Replacement**

- Drain the coolant (see Coolant Change).
- Remove:
  - Middle Fairings (see Middle Fairing Removal in the Frame chapter)
  - Throttle Body Assy (see Throttle Body Assy Removal in the Fuel System (DFI) chapter)
  - Thermostat Housing Cover [A] (see Thermostat Removal in the Cooling System chapter)
  - Fitting [B]
  - Hoses [C]
  - O-rings [D]
- Apply grease to the new O-rings and install them.
- Install the new hoses and tighten the clamps securely.
- Tighten:
  - Torque - Water Hose Clamp Screws: 2.0 N-m (0.20 kgf-m, 17 in-lb)**
- Install the removed parts.
- Fill the coolant (see Coolant Change).
- Install the hose correctly (see Cable, Wire, and Hose Routing in the Appendix chapter)
- Check the cooling system for leaks.

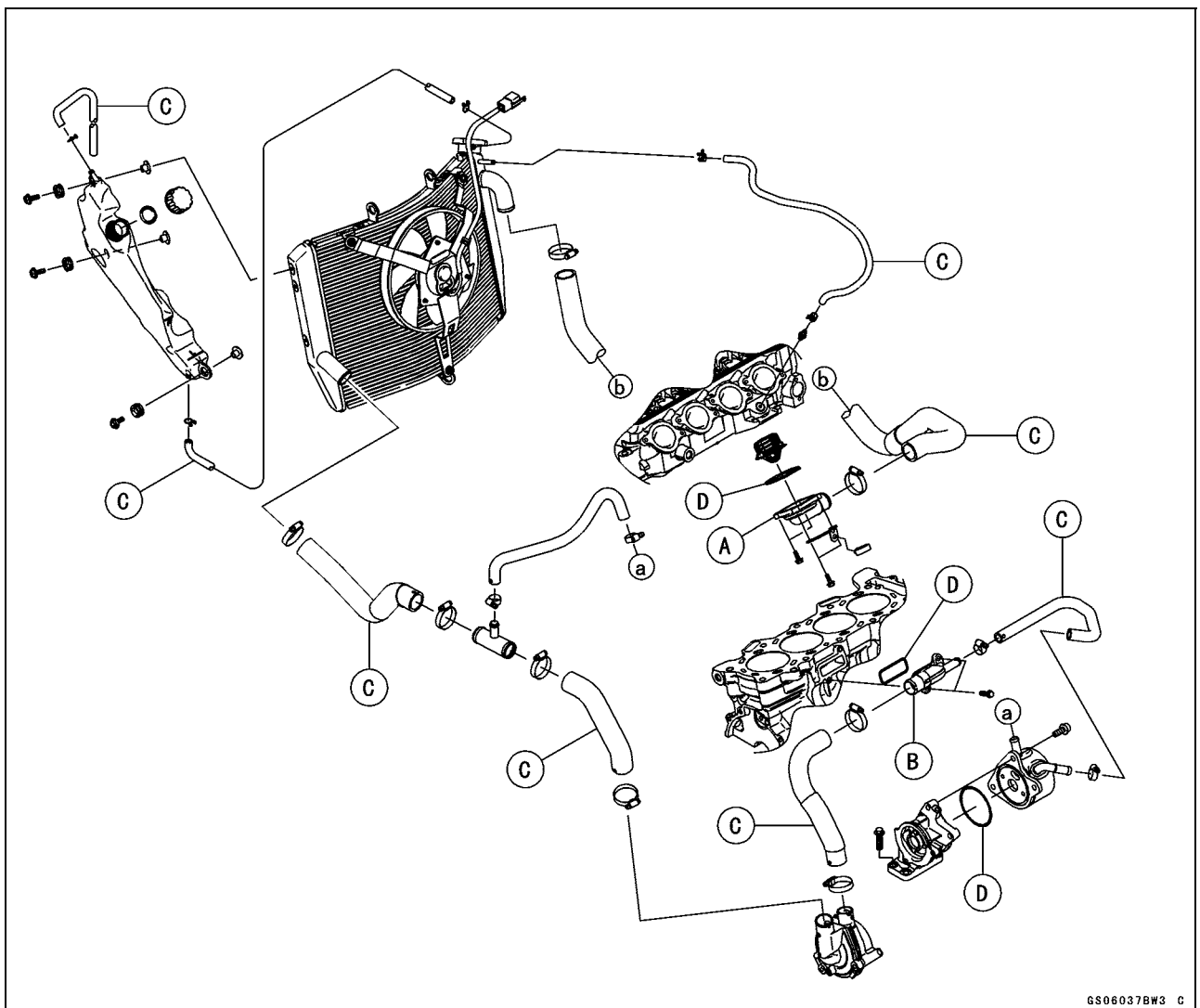

## 2-52 PERIODIC MAINTENANCE

### Maintenance Procedure

#### Engine Oil Change

- Remove the left lower fairing (see Lower Fairing Removal in the Frame chapter).
- Situate the motorcycle so that it is vertical after warming up the engine.
- Remove the engine oil drain bolt [A] to drain the oil.
- The oil in the oil filter can be drained by removing the filter (see Oil Filter Replacement).
- ★ Replace the drain bolt gasket with a new one.
- Tighten the drain bolt.

**Torque - Engine Oil Drain Bolt: 29 N·m (3.0 kgf·m, 22 ft·lb)**

- Pour in the specified type and amount of oil.

#### Recommended Engine Oil

**Type:** API SE, SF or SG

API SH, SJ or SL with JASO MA

**Viscosity:** SAE 10W-40

**Capacity:** 2.9 L (3.1 US qt) (when filter is not removed)

3.2 L (3.4 US qt) (when filter is removed)

3.8 L (4.0 US qt) (when engine is completely dry)

#### NOTE

○ Although 10W-40 engine oil is the recommended oil for most conditions, the oil viscosity may need to be changed to accommodate atmospheric conditions in your riding area.

#### Oil Filter Replacement

- Drain the engine oil (see Engine Oil Change).
  - Remove the oil filter [A] with the oil filter wrench [B].
- Special Tool - Oil Filter Wrench: 57001-1249**
- With a high-flash point solvent, clean the oil filter guard and wipe up with wet cloth.

- Replace the filter with a new one.
- Apply engine oil to the gasket [A] before installation.
- Tighten the filter with the oil filter wrench.

**Torque - Oil Filter: 31 N·m (3.2 kgf·m, 23 ft·lb)**

#### NOTE

○ Hand tightening of the oil filter can not be allowed since it does not reach to this tightening torque.

- Pour in the specified type and amount of oil (see Engine Oil Change).

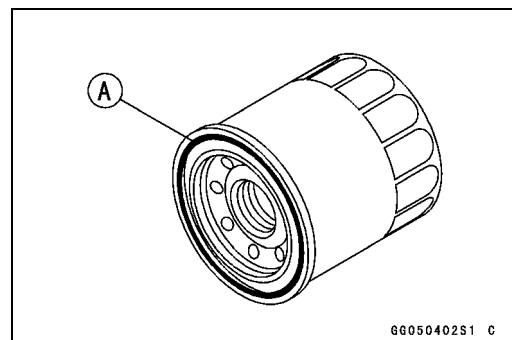
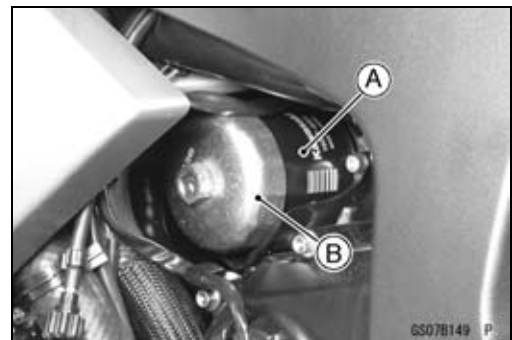
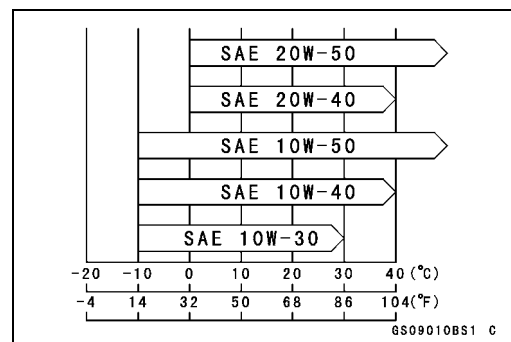
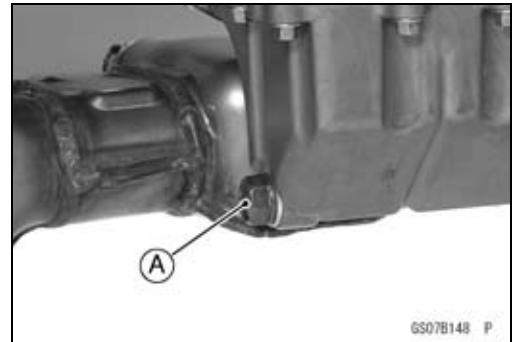

**Maintenance Procedure**

**Brake Hose and Pipe Replacement**

**CAUTION**

**Brake fluid quickly ruins painted plastic surfaces; any spilled fluid should be completely washed away immediately.**

- Remove the brake hose banjo bolts [A] and washers.
- When removing the brake hose, take care not to spill the brake fluid on the painted or plastic parts.
- When removing the brake hoses [B], temporarily secure the end of the brake hose to some high place to keep fluid loss to a minimum.
- Immediately wash away any brake fluid that spills.
- There are washers on each side of the brake hose fitting. Replace them with new ones when installing.
- Tighten:
  - Torque - Brake Hose Banjo Bolts: 25 N·m (2.5 kgf·m, 18 ft·lb)**
- When installing the hoses, avoid sharp bending, kinking, flattening or twisting, and route the hoses according to Cable, Wire, and Hose Routing section in the Appendix chapter.
- Fill the brake line after installing the brake hose (see Brake Fluid Change).

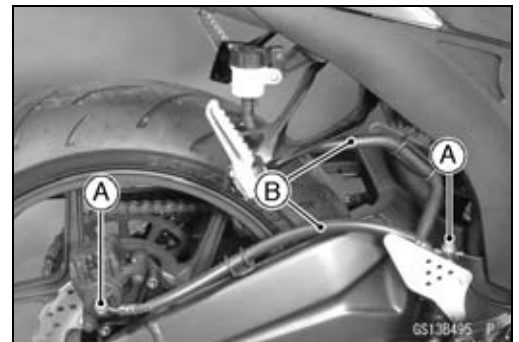
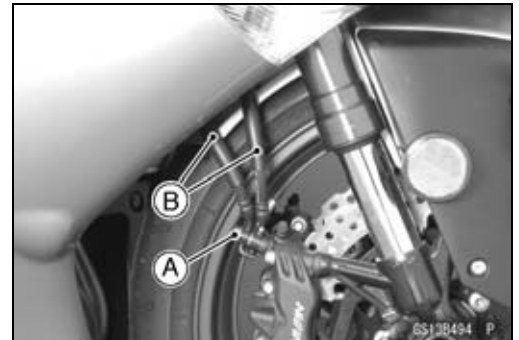
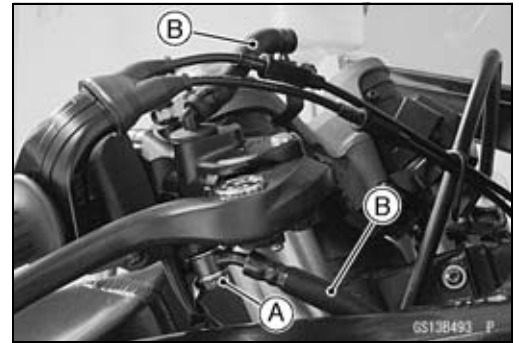

**Brake Fluid Change**

**NOTE**

○ The procedure to change the front brake fluid is as follows. Changing the rear brake fluid is the same as for the front brake.

- Level the brake fluid reservoir.
- Remove:
  - Screw [A]
  - Stopper [B]
  - Reservoir Cap [C]
- Remove the rubber cap from the bleed valve [A] on the caliper.
- Attach a clear plastic hose [B] to the bleed valve, and run the other end of the hose into a container.
- Fill the reservoir with fresh specified brake fluid.

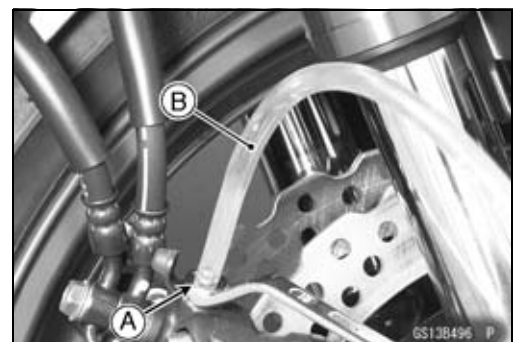
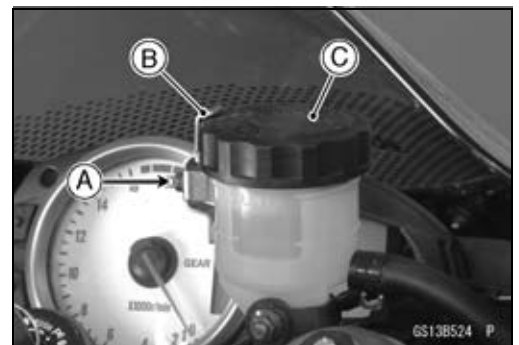

## 2-54 PERIODIC MAINTENANCE

### Maintenance Procedure

- Change the brake fluid.
- Repeat this operation until fresh brake fluid comes out from the plastic hose or the color of the fluid changes.
  1. Open the bleed valve [A].
  2. Apply the brake and hold it [B].
  3. Close the bleed valve [C].
  4. Release the brake [D].

#### NOTE

- The fluid level must be checked often during the changing operation and replenished with fresh brake fluid. If the fluid in the reservoir runs out any time during the changing operation, the brakes will need to be bled since air will have entered the brake line.
- Front Brake: Repeat the above steps for the other caliper.

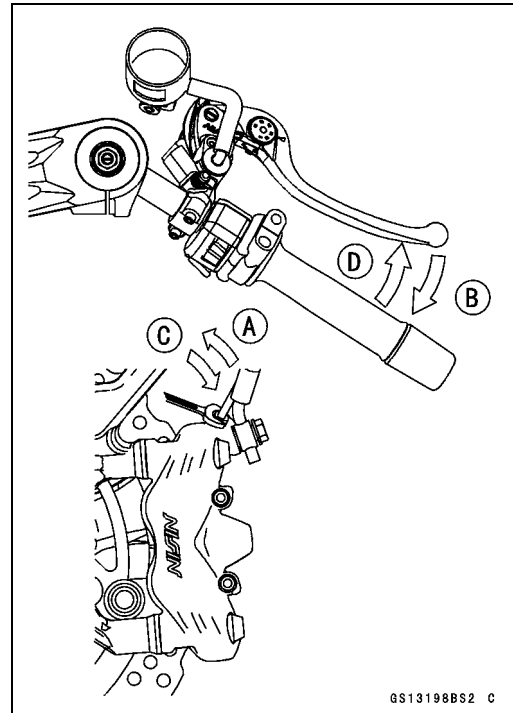

- Follow the procedure below to install the front/rear brake fluid reservoir cap correctly.
- First, tighten the brake fluid reservoir cap [B] clockwise [C] by hand until the resistance is felt fully; then, tighten the cap an additional 1/6 turn [D] while holding the brake fluid reservoir body [A].

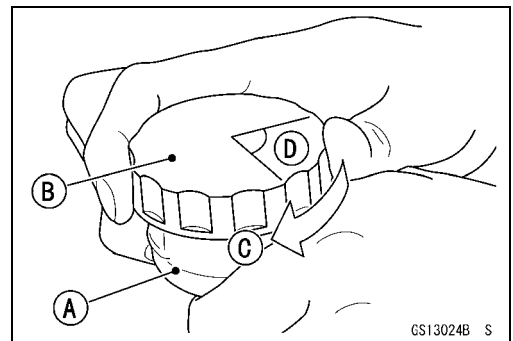

- Tighten:
  - Torque - Front Brake Reservoir Cap Stopper Screw: 1.2 N-m (0.12 kgf-m, 10 in-lb)**
- Tighten the bleed valve, and install the rubber cap.
  - Torque - Bleed Valve: 7.8 N-m (0.80 kgf-m, 69 in-lb)**
- After changing the fluid, check the brake for good braking power, no brake drag, and no fluid leakage.
- ★ If necessary, bleed the air from the lines.

**Maintenance Procedure**

**Master Cylinder Rubber Parts Replacement**

**Front Master Cylinder Disassembly**

- Remove the front master cylinder (see Front Master Cylinder Removal in the Brakes chapter).
- Remove the seal cover [A], circlip [B], connector [C] and O-ring [D].

**Special Tool - Inside Circlip Pliers: 57001-143**

- Unscrew the locknut [E] and pivot bolt [F], and remove the brake lever.
- Remove dust cover and circlip [G].
- Pull out the piston assy [H].
- Replace:
  - Seal Cover [A]
  - Circlip [B]
  - O-ring [D]
  - Circlip [G]
  - Piston Assy [H] with dust cover

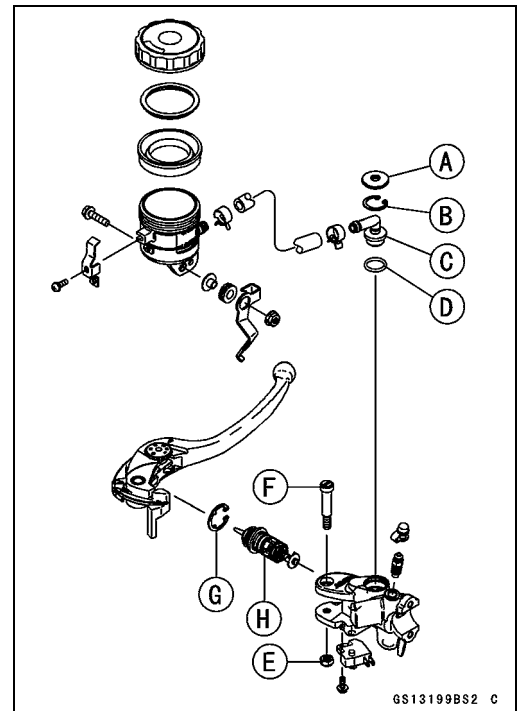

**Rear Master Cylinder Disassembly**

- Remove the rear master cylinder (see Rear Master Cylinder Removal in the Brakes chapter).
- Remove the circlip [A], connector [B] and O-ring [C].

**Special Tool - Inside Circlip Pliers: 57001-143**

- Slide the dust cover [D] out of place, and remove the circlip [E].
- Pull out the push rod assy [F].
- Take off the piston assy [G].

**CAUTION**

**Do not remove the secondary cup from the piston since removal will damage it.**

- Replace:
  - Circlip [A]
  - O-ring [C]
  - Circlip [E]
  - Push Rod Assy [F]
  - Piston Assy [G]

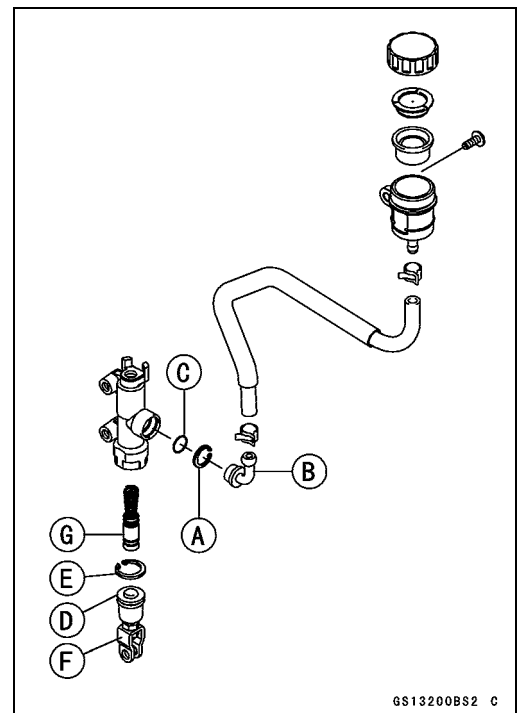

**Master Cylinder Assembly**

- Before assembly, clean all parts including the master cylinder with brake fluid or alcohol.

**CAUTION**

**Except for the disc pads and disc, use only disc brake fluid, isopropyl alcohol, or ethyl alcohol for cleaning brake parts. Do not use any other fluid for cleaning these parts. Gasoline, engine oil, or any other petroleum distillate will cause deterioration of the rubber parts. Oil spilled on any part will be difficult to wash off completely, and will eventually deteriorate the rubber used in the disc brake.**

## 2-56 PERIODIC MAINTENANCE

### Maintenance Procedure

- Apply brake fluid to the new parts and to the inner wall of the cylinder.
- Take care not to scratch the piston or the inner wall of the cylinder.
- Tighten the brake lever pivot bolt and the locknut.

**Silicone Grease - Brake Lever Pivot Bolt**

**Torque - Brake Lever Pivot Bolt: 1.0 N·m (0.10 kgf·m, 9 in·lb)**

**Brake Lever Pivot Bolt Locknut: 5.9 N·m (0.60 kgf·m, 52 in·lb)**

### Caliper Rubber Parts Replacement

#### Front Caliper Disassembly

- Loosen the front caliper pad pins [A] and banjo bolt [B] and tighten them loosely.
- Remove:
  - Front Caliper [C] (see Front Caliper Removal in the Brakes chapter)
  - Brake Pad (see Front Brake Pad Removal in the Brakes chapter)
  - Front Caliper Assembly Bolts
  - O-rings

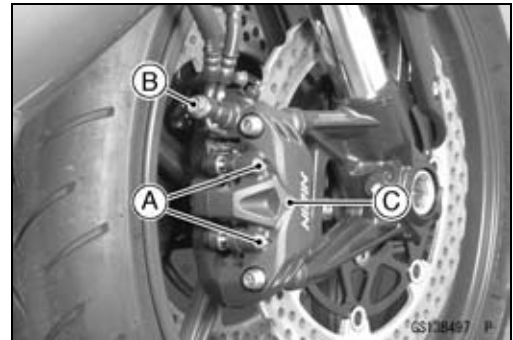

- Using compressed air, remove the pistons. One way to remove the pistons is as follows.
- Install a rubber gasket [A] and a wooden board [B] more than 10 mm (0.4 in.) thick on the caliper half, and fasten them together with a suitable bolt and nut as shown. Leave one of the oil passages [C] open.
- Lightly apply compressed air [D] to the oil passage until the pistons hit the rubber gasket.
- For the hose joint side caliper half, block the hose joint opening during this operation if the caliper half has the opening.
  - Bolt and Nut [E]
  - Push down [F].

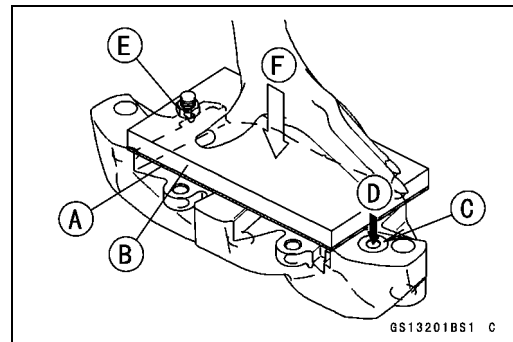

### **⚠ WARNING**

**To avoid serious injury, never place your fingers or palm in front of the piston. If you apply compressed air into the caliper, the piston may crush your hand or fingers.**

- Pull out the pistons by hand.
- Remove the dust seals [A] and fluid seals [B].
- Remove the bleed valve [C] and rubber cap [D].
- Repeat the previous step to remove the pistons from the other side of the caliper body.

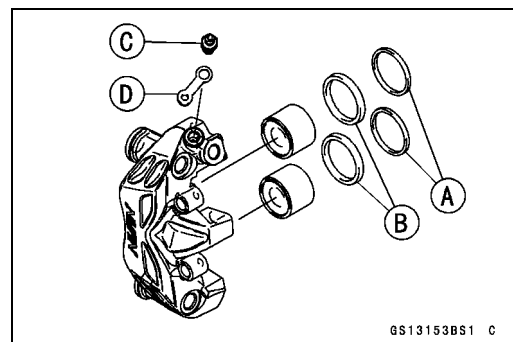

**Maintenance Procedure**

**NOTE**

- If compressed air is not available, do as follows for both calipers coincidentally, with the brake hose connected to the caliper.
- Prepare a container for brake fluid, and perform the work above it.
- Remove the pad spring and pads (see Front Brake Pad Removal in the Brakes chapter).
- Pump the brake lever until the pistons come out of the cylinders, and then disassemble the caliper.

**Front Caliper Assembly**

- Clean the caliper parts except for the pads.

**CAUTION**

**For cleaning the parts, use only disc brake fluid, isopropyl alcohol, or ethyl alcohol.**

- Install the bleed valve and rubber cap.
- Torque - Bleed Valve: 7.8 N·m (0.80 kgf·m, 69 in·lb)**
- Replace the fluid seals [A] with new ones.
- Apply silicone grease to the fluid seals, and install them into the cylinders by hand.
- Replace the dust seals [B] with new ones if they are damaged.
- Apply silicone grease to the dust seals, and install them into the cylinders by hand.

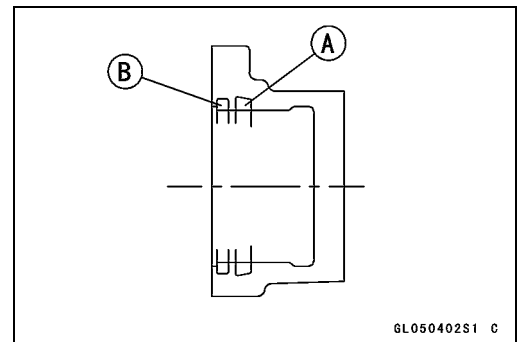

- Replace the O-ring [A].
- Apply brake fluid to the outside of the pistons, and push them into each cylinder by hand.
- Be sure to install the O-rings.
- Tighten:
- Torque - Front Caliper Assembly Bolts: 27 N·m (2.8 kgf·m, 20 ft·lb)**

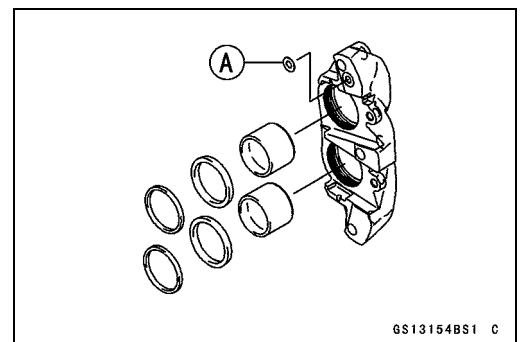

- Install the pads (see Front Brake Pad Installation in the Brakes chapter).
- Wipe up any spilled brake fluid on the caliper with wet cloth.

## 2-58 PERIODIC MAINTENANCE

### Maintenance Procedure

#### Rear Caliper Disassembly

- Remove the rear caliper (see Rear Caliper Removal in the Brakes chapter).
- Remove the pads and pad springs (see Rear Brake Pad Removal in the Brakes chapter).
- Using compressed air, remove the piston.
  - Cover the caliper opening with a clean, heavy cloth [A].
  - Remove the piston by lightly applying compressed air [B] to where the brake line fits into the caliper.

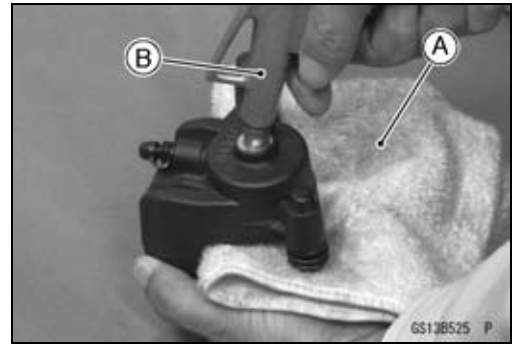

#### **⚠ WARNING**

**To avoid serious injury, never place your fingers or palm inside the caliper opening. If you apply compressed air into the caliper, the piston may crush your hand or fingers.**

- Remove the dust seal and fluid seal.
- Remove the bleed valve and rubber cap.

#### **NOTE**

- If compressed air is not available, do as follows with the brake hose connected to the caliper.
- Prepare a container for brake fluid, and perform the work above it.
- Remove the pads and pad spring (see Rear Brake Pad Removal in the Brakes chapter).
- Pump the brake pedal to remove the caliper piston.

#### Rear Caliper Assembly

- Clean the caliper parts except for the pads.

#### **CAUTION**

**For cleaning of the parts, use only disc brake fluid, isopropyl alcohol, or ethyl alcohol.**

- Install the bleed valve and rubber cap.
  - Torque - Bleed Valve: 7.8 N-m (0.80 kgf-m, 69 in-lb)**
- Replace the fluid seal [A] with a new one.
  - Apply rubber grease to the fluid seal, and install it into the cylinder by hand.
- Replace the dust seal [B] with a new one.
  - Apply rubber grease to the dust seal, and install it into the cylinder by hand.

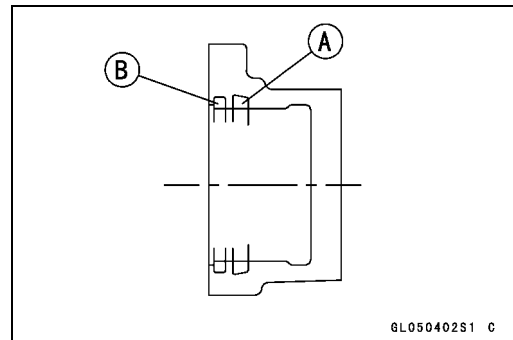



**Maintenance Procedure**

- Install the pad spring [A] in the caliper as shown.
- Apply brake fluid to the outside of the piston [B], and push it into the cylinder by hand.
- Replace the shaft rubber friction boot [C] and dust boot [D].

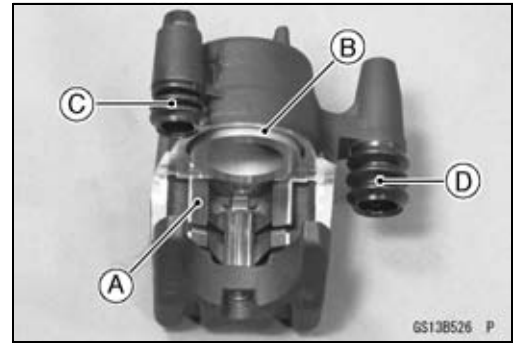

- Install the pad spring [A] on the caliper holder as shown.
- Apply a thin coat of PBC (Poly Butyl Cuprysil) grease to the caliper holder shafts [B] and holder holes (PBC is a special high temperature, water-resistance grease).
- Install the pads (see Rear Brake Pad Installation in the Brakes chapter).
- Wipe up any spilled brake fluid on the caliper with wet cloth.

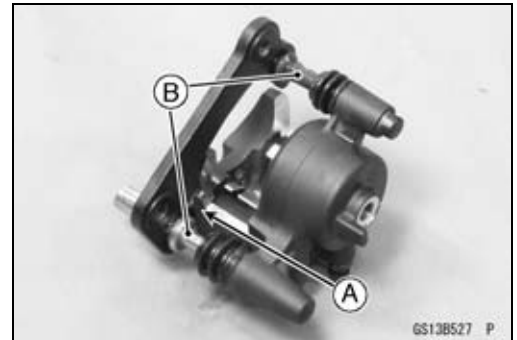

**Spark Plug Replacement**

- Remove:
  - Stick Coils (see Stick Coil Removal in the Electrical System chapter)
- Remove the spark plug using the 16 mm (0.63 in.) plug wrench [A] vertically.
- **Owner's Tool - Spark Plug Wrench, 16 mm: 92110-1132**
- Replace the spark plug with a new one.



**Standard Spark Plug**  
 Type: **NGK CR9E**

- Insert new spark plug in the plug hole, and finger-tighten it first.
- Using the plug wrench [A] vertically, tighten the plug.

**CAUTION**

**The insulator of the spark plug may break if when the wrench is inclined during tightening.**

**Torque - Spark Plugs: 13 N·m (1.3 kgf·m, 113 in·lb)**

- Install the stick coils securely.
- Be sure the stick coils are installed by pulling up it lightly.





# Fuel System (DFI)

## Table of Contents

Exploded View .....	3-4	Water Temperature Sensor Resistance Inspection .....	3-55
Specifications .....	3-10	Atmospheric Pressure Sensor (Service Code 15).....	3-56
Special Tools and Sealant .....	3-12	Atmospheric Pressure Sensor Removal .....	3-56
DFI Parts Location.....	3-14	Atmospheric Pressure Sensor Installation .....	3-56
DFI System.....	3-16	Atmospheric Pressure Sensor Input Voltage Inspection.....	3-56
DFI Servicing Precautions.....	3-21	Atmospheric Pressure Sensor Output Voltage Inspection .....	3-57
Troubleshooting the DFI System .....	3-23	Crankshaft Sensor (Service Code 21).....	3-60
Outline .....	3-23	Crankshaft Sensor Removal/Installation.....	3-60
Inquiries to Rider.....	3-27	Crankshaft Sensor Inspection.....	3-60
DFI System Troubleshooting Guide ..	3-30	Camshaft Position Sensor (Service Code 23).....	3-61
Self-Diagnosis .....	3-35	Camshaft Position Sensor Removal/Installation.....	3-61
Self-diagnosis Outline.....	3-35	Camshaft Position Sensor Inspection.....	3-61
Self-diagnosis Procedures.....	3-36	Speed Sensor (Service Code 24).....	3-62
Service Code Reading.....	3-38	Speed Sensor Removal/Installa- tion .....	3-62
Service Code Erasing .....	3-38	Speed Sensor Inspection.....	3-62
Backups .....	3-40	Speed Sensor Input Voltage Inspection.....	3-62
Main Throttle Sensor (Service Code 11).....	3-43	Speed Sensor Output Voltage Inspection.....	3-62
Main Throttle Sensor Removal/Adjustment.....	3-43	Gear Position Switch (Service Code 25).....	3-64
Main Throttle Sensor Input Voltage Inspection.....	3-43	Gear Position Switch Removal/Installation.....	3-64
Main Throttle Sensor Output Voltage Inspection.....	3-44	Gear Position Switch Inspection ..	3-64
Main Throttle Sensor Resistance Inspection.....	3-45	Gear Position Switch Input Voltage Inspection.....	3-64
Inlet Air Pressure Sensor (Service Code 12).....	3-47	Vehicle-down Sensor (Service Code 31).....	3-66
Inlet Air Pressure Sensor Removal.....	3-47	Vehicle-down Sensor Removal....	3-66
Inlet Air Pressure Sensor Installation.....	3-47	Vehicle-down Sensor Installation..	3-66
Inlet Air Pressure Sensor Input Voltage Inspection.....	3-47	Vehicle-down Sensor Inspection..	3-67
Inlet Air Pressure Sensor Output Voltage Inspection.....	3-48	Subthrottle Sensor (Service Code 32).....	3-70
Inlet Air Temperature Sensor (Service Code 13).....	3-52	Subthrottle Sensor Removal/Adjustment.....	3-70
Inlet Air Temperature Sensor Removal/Installation.....	3-52	Subthrottle Sensor Input Voltage Inspection.....	3-70
Inlet Air Temperature Sensor Output Voltage Inspection.....	3-52		
Inlet Air Temperature Sensor Resistance Inspection.....	3-53		
Water Temperature Sensor (Service Code 14).....	3-54		
Water Temperature Sensor Removal/Installation.....	3-54		
Water Temperature Sensor Output Voltage Inspection.....	3-54		

## 3-2 FUEL SYSTEM (DFI)

Subthrottle Sensor Output Voltage Inspection.....	3-71	Exhaust Butterfly Valve Actuator Inspection.....	3-91
Resistance Inspection.....	3-73	Exhaust Butterfly Valve Actuator Output Voltage Inspection .....	3-91
Oxygen Sensor-not activated (#1, #2: Service Code 33, 83)-Equipped Models .....	3-74	Air Switching Valve (Service Code 64).....	3-93
Oxygen Sensor Removal/Installation .....	3-74	Air Switching Valve Removal/Installation.....	3-93
Oxygen Sensor Inspection.....	3-74	Air Switching Valve Inspection .....	3-93
Exhaust Butterfly Valve Actuator Sensor (Service Code 34) .....	3-76	Oxygen Sensor Heaters (#1, #2: Service Code 67)-Equipped Models .....	3-94
Exhaust Butterfly Valve Actuator Sensor Removal/Installation .....	3-76	Oxygen Sensor Heater Removal/Installation.....	3-94
Exhaust Butterfly Valve Actuator Sensor Input Voltage Inspection .....	3-76	Oxygen Sensor Heater Inspection .....	3-94
Exhaust Butterfly Valve Actuator Sensor Output Voltage Inspection.....	3-77	Oxygen Sensors-Incorrect Output Voltage (#1, #2: Service Code 94, 95)-Equipped Models.....	3-96
Exhaust Butterfly Valve Actuator Sensor Inspection .....	3-78	Oxygen Sensor Removal/Installation .....	3-96
Immobilizer Amplifier (Service Code 35)-Equipped Models.....	3-79	Oxygen Sensor Inspection.....	3-96
Antenna Resistance Inspection ...	3-79	ECU.....	3-98
Amplifier Input Voltage Inspection .....	3-79	ECU Identification .....	3-98
Blank Key Detection (Service Code 36).....	3-80	ECU Removal .....	3-98
User Key Inspection.....	3-80	ECU Installation .....	3-99
ECU Communication Error (Service Code 39).....	3-82	ECU Power Supply Inspection.....	3-99
ECU Communication Line Inspection.....	3-82	DFI Power Source .....	3-101
Stick Coils #1, #2, #3, #4: (Service Code 51, 52, 53, 54).....	3-83	ECU Fuse Removal .....	3-101
Stick Coil Removal/Installation.....	3-83	ECU Fuse Installation .....	3-101
Stick Coil Input Voltage Inspection.....	3-83	ECU Fuse Inspection.....	3-101
Radiator Fan Relay (Service Code 56).....	3-85	Warning Indicator Light (LED) .....	3-102
Radiator Fan Relay Removal/Installation.....	3-85	Warning Indicator Light (LED) Inspection.....	3-102
Radiator Fan Relay Inspection.....	3-85	Fuel Line.....	3-103
Subthrottle Valve Actuator (Service Code 62).....	3-87	Fuel Pressure Inspection .....	3-103
Subthrottle Valve Actuator Removal .....	3-87	Fuel Flow Rate Inspection .....	3-104
Subthrottle Valve Actuator Inspection.....	3-87	Fuel Pump .....	3-106
Subthrottle Valve Actuator Resistance Inspection .....	3-87	Fuel Pump Removal .....	3-106
Subthrottle Valve Actuator Input Voltage Inspection.....	3-88	Fuel Pump Installation .....	3-106
Exhaust Butterfly Valve Actuator (Service Code 63).....	3-89	Fuel Pump Operation Inspection .	3-107
Exhaust Butterfly Valve Actuator Removal .....	3-89	Fuel Pump Operating Voltage Inspection.....	3-107
Exhaust Butterfly Valve Actuator Installation .....	3-89	Fuel Pump Relay .....	3-109
		Fuel Pump Relay Removal .....	3-109
		Fuel Pump Relay Inspection .....	3-109
		Fuel Injectors .....	3-110
		Audible Inspection.....	3-110
		Injector Signal Test.....	3-110
		Injector Resistance Inspection .....	3-111
		Injector Unit Test .....	3-112
		Injector Voltage Inspection.....	3-112
		Injector Fuel Line Inspection .....	3-114
		Throttle Grip and Cables .....	3-116
		Free Play Inspection .....	3-116
		Free Play Adjustment.....	3-116
		Cable Installation .....	3-116

---

Cable Lubrication .....	3-116	Air Cleaner Housing Removal.....	3-124
Throttle Body Assy .....	3-117	Air Cleaner Housing Installation...	3-125
Idle Speed Inspection .....	3-117	Air Cleaner Housing Disassembly	3-126
Synchronization Inspection .....	3-117	Air Cleaner Housing Assembly ....	3-126
Synchronization Adjustment .....	3-117	Oil Draining .....	3-127
Throttle Body Assy Removal.....	3-117	Fuel Tank.....	3-128
Throttle Body Assy Installation.....	3-118	Fuel Tank Removal .....	3-128
Throttle Body Assy Disassembly .	3-119	Fuel Tank Installation .....	3-130
Throttle Body Assy Assembly .....	3-120	Fuel Tank and Cap Inspection ....	3-130
Nozzle Assy.....	3-121	Fuel Tank Cleaning .....	3-131
Nozzle Assy Removal.....	3-121	Evaporative Emission Control System	
Nozzle Assy Installation.....	3-121	(California Model) .....	3-132
Nozzle Assy Disassembly.....	3-122	Parts Removal/Installation .....	3-132
Nozzle Assy Assembly.....	3-122	Hose Inspection .....	3-132
Air Cleaner.....	3-124	Separator Inspection.....	3-132
Air Cleaner Element Removal.....	3-124	Separator Operation Test.....	3-133
Air Cleaner Element Installation...	3-124	Canister Inspection .....	3-133
Air Cleaner Element Inspection ...	3-124		

# 3-4 FUEL SYSTEM (DFI)

## Exploded View

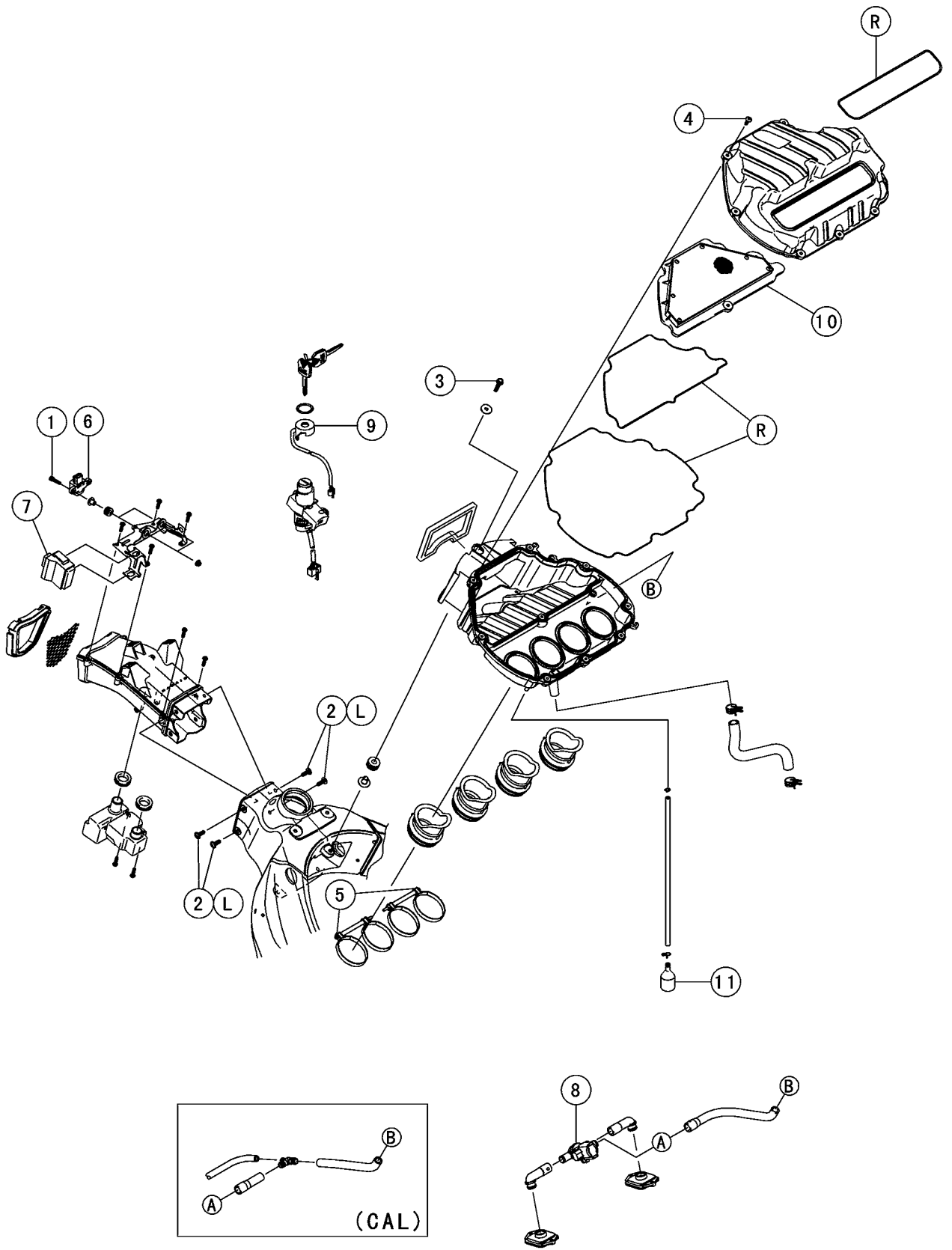

**Exploded View**

No.	Fastener	Torque			Remarks
		N-m	kgf-m	ft-lb	
1	Vehicle-down Sensor Bolts	5.9	0.60	52 in-lb	
2	Air Inlet Duct Mounting Bolts	9.8	1.0	87 in-lb	L
3	Air Cleaner Housing Mounting Bolt	6.9	0.70	61 in-lb	
4	Air Cleaner Housing Screws	1.1	0.11	9.7 in-lb	
5	Air Cleaner Housing Clamp Bolts	2.0	0.20	17 in-lb	

- 6. Vehicle-down Sensor
  - 7. Immobilizer Amplifier
  - 8. Air Switching Valve
  - 9. Immobilizer Antenna
  - 10. Air Cleaner Element
  - 11. Catch Tank
- L: Apply a non-permanent locking agent.  
R: Replacement Parts

# 3-6 FUEL SYSTEM (DFI)

## Exploded View

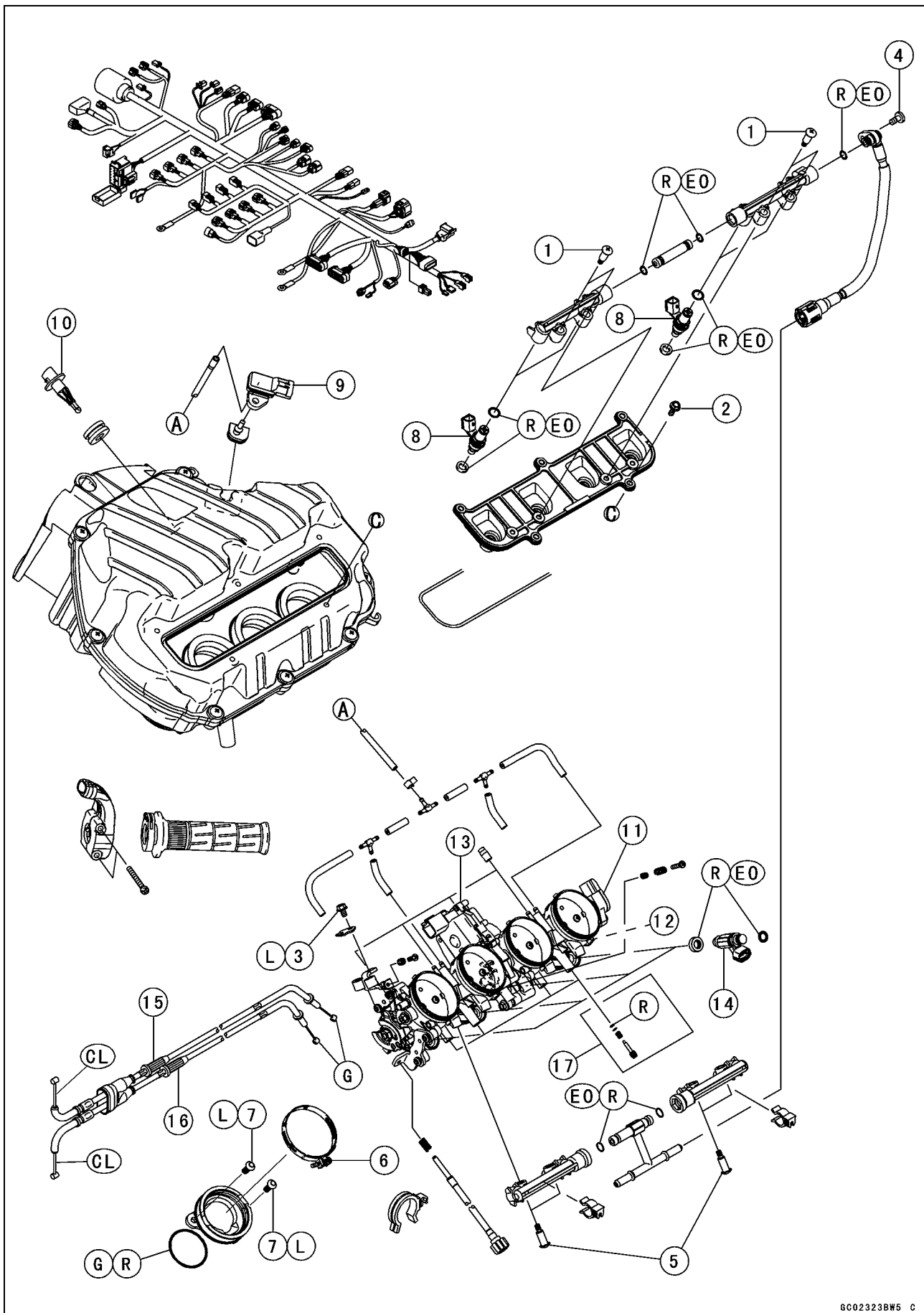



**Exploded View**

No.	Fastener	Torque			Remarks
		N·m	kgf·m	ft·lb	
1	Delivery Pipe Mounting Screws (Nozzle Assy)	3.4	0.35	30 in·lb	
2	Nozzle Assy Mounting Bolts	6.9	0.70	61 in·lb	
3	Throttle Cable Holder Plate Bolt	3.9	0.40	35 in·lb	L
4	Nozzle Assy Fuel Hose Screw	4.9	0.50	43 in·lb	
5	Delivery Pipe Mounting Screws (Throttle Body)	3.4	0.35	30 in·lb	
6	Throttle Body Assembly Holder Clamp Bolts	3.0	0.30	27 in·lb	
7	Throttle Body Holder Bolts	12	1.2	104 in·lb	L

- 8. Secondary Fuel Injectors
  - 9. Inlet Air Pressure Sensor
  - 10. Inlet Air Temperature Sensor
  - 11. Subthrottle Sensor
  - 12. Main Throttle Sensor
  - 13. Subthrottle Valve Actuator
  - 14. Primary Fuel Injectors
  - 15. Throttle Cable (Accelerator)
  - 16. Throttle Cable (Decelerator)
  - 17. Bypass Screw
- CL: Apply cable lubricant.  
 EO: Apply engine oil.  
 G: Apply grease.  
 L: Apply a non-permanent locking agent.  
 R: Replacement Parts



**Exploded View**

No.	Fastener	Torque			Remarks
		N·m	kgf·m	ft·lb	
1	Separator Bracket Mounting Bolt	0.8	0.08	7 in·lb	
2	Spark Plugs	13	1.3	113 in·lb	
3	Camshaft Position Sensor Bolt	9.8	1.0	87 in·lb	
4	Water Temperature Sensor	25	2.5	18	SS
5	Crankshaft Sensor Bolts	5.9	0.60	52 in·lb	
6	Fuel Pump Bolts	9.8	1.0	87 in·lb	L, S
7	Exhaust Butterfly Valve Actuator Mounting Nuts	6.9	0.70	61 in·lb	
8	Gear Position Switch Screws	2.9	0.30	26 in·lb	L
9	Speed Sensor Bolt	3.9	0.40	35 in·lb	L
10	Exhaust Butterfly Valve Actuator Pulley Bolt	4.9	0.50	43 in·lb	

- 11. Canister
  - 12. Separator
  - 13. Relay Box
  - 14. Battery 12 V 8 Ah
  - 15. Atmospheric Pressure Sensor
  - 16. ECU
  - 17. Stick Coil
  - 18. Fuel Pump
  - 19. Exhaust Butterfly Valve
  - 20. Crankshaft Sensor
  - 21. Speed Sensor
  - 22. Gear Position Sensor
  - 23. Exhaust Butterfly Valve Actuator
  - 24. Camshaft Position Sensor
- G: Apply grease.  
L: Apply a non-permanent locking agent.  
R: Replacement Parts  
S: Follow the specific tightening sequence.  
SS: Apply silicone sealant.

## 3-10 FUEL SYSTEM (DFI)

### Specifications

Item	Standard
<b>Digital Fuel Injection System</b>	
Idle Speed	1 300 ±50 r/min (rpm)
Throttle Assy:	
Type	Oval type
Bore	φ38 mm (1.5 in.)
Throttle Body Vacuum	27.3 ±1.0 kPa (205 ±10 mmHg)
Bypass Screws	— — —
ECU (Electronic Control Unit):	
Make	Denso
Type	Digital memory type, with built in IC igniter, sealed with resin
Fuel Pressure (High Pressure Line):	
Right after Ignition Switch ON, with fuel pump running for 3 seconds with engine idling	294 kPa (3.0 kgf/cm <sup>2</sup> , 43 psi) with fuel pump running 280 kPa (2.9 kgf/cm <sup>2</sup> , 41 psi) with fuel pump stopped
Fuel Pump:	
Type	In-tank pump (in fuel tank), or Wesco pump (friction pump)
Discharge	67 mL (2.27 US oz) or more for 3 seconds
Primary Fuel Injectors:	
Type	INP-288
Nozzle Type	Fine atomizing type with 8 holes
Resistance	About 11.7 ~ 12.3 Ω at 20°C (68°F)
Secondary Fuel Injectors:	
Nozzle Type	Multihole type with 8 holes
Resistance	About 10.5 Ω at 20°C (68°F)
Main Throttle Sensor:	Non-adjustable and non-removable
Input Voltage	DC 4.75 ~ 5.25 V between BL and BR/BK leads
Output Voltage	DC 1.04 ±0.015 V between Y/W and BR/BK leads (at idle throttle opening)
Resistance	4 ~ 6 kΩ
Inlet Air Pressure Sensor/Atmospheric Pressure Sensor:	
Input Voltage	DC 4.75 ~ 5.25 V between BL and BR/BK leads
Output Voltage	DC 3.80 ~ 4.20 V between Y/BL and BR/BK leads at standard atmospheric pressure (see this text for details)
Inlet Air Temperature Sensor:	
Resistance	1.6 ~ 3.7 kΩ at 20°C (68°F) 0.24 ~ 0.43 kΩ at 80°C (176°F)
Output Voltage at ECU	About 2.25 ~ 2.50 V at 20°C (68°F)
Water Temperature Sensor:	
Resistance	see Electrical System chapter
Output Voltage at ECU	About 3 ~ 6 V at 20°C (68°F)
Speed Sensor:	
Input Voltage at Sensor	About DC 9 ~ 11 V at Ignition Switch ON
Output Voltage at Sensor	About DC 0.05 ~ 0.07 V at Ignition Switch ON and 0 km/h

**Specifications**

Item	Standard
Vehicle-down Sensor: Detection Method Detection Angle Detection Time Output Voltage	Magnetic flux detection method More than 60 ~ 70° for each bank with in 1.0 ~ 1.5 sec. with sensor arrow mark pointed up: 3.55 ~ 4.45 V with sensor tilted 60 ~ 70° or more: 0.65 ~ 1.35 V
Subthrottle Sensor: Input Voltage Output Voltage Resistance	Non-adjustable and non-removal DC 4.75 ~ 5.25 V between BL and BR/BK leads DC 1.1 ±0.02 V between BR and BR/BK leads (completely closed) 4 ~ 6 kΩ
Exhaust Butterfly Valve Actuator Sensor: Input Voltage Output Voltage Resistance	DC 4.75 ~ 5.25 V DC 3.46 ~ 3.76 V at pulley original position 4 ~ 6 kΩ
Immobilizer Amplifier: Antenna Resistance	About 0.6 ~ 0.9 Ω
Exhaust Butterfly Valve Actuator: Resistance	5 ~ 200 Ω (for reference)
Subthrottle Valve Actuator: Resistance Input Voltage	About 5.5 ~ 7.5 Ω About DC 8.0 ~ 16.0 V
Oxygen Sensor: Output Voltage (Rich) Output Voltage (Lean) Heater Resistance	0.45 ~ 2.5 V 0.05 ~ 0.45 V About 8 Ω at 20°C (68°F)
<b>Throttle Grip and Cables</b> Throttle Grip Free Play	2 ~ 3 mm (0.08 ~ 0.12 in.)

# 3-12 FUEL SYSTEM (DFI)

## Special Tools and Sealant

**Oil Pressure Gauge, 5 kgf/cm<sup>2</sup>:**  
57001-125

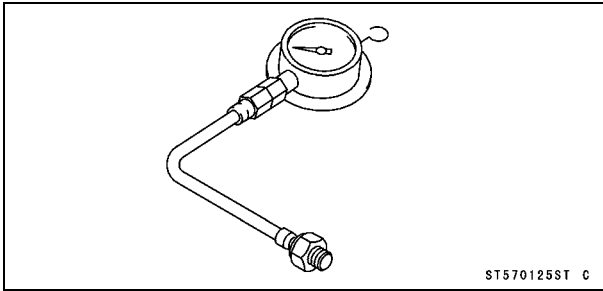

**Needle Adapter Set:**  
57001-1457

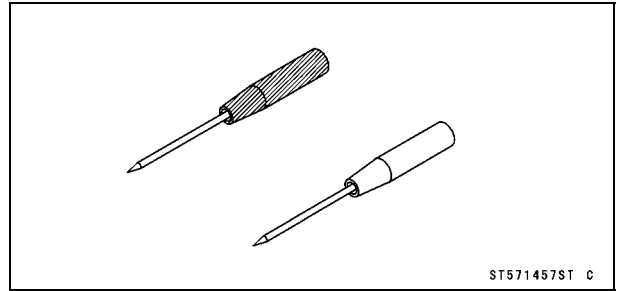

**Carburetor Drain Plug Wrench, Hex 3:**  
57001-1269

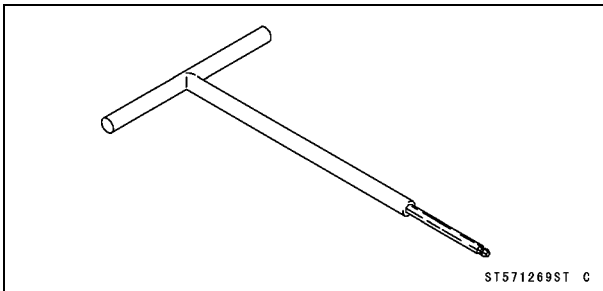

**Throttle Sensor Setting Adapter:**  
57001-1538

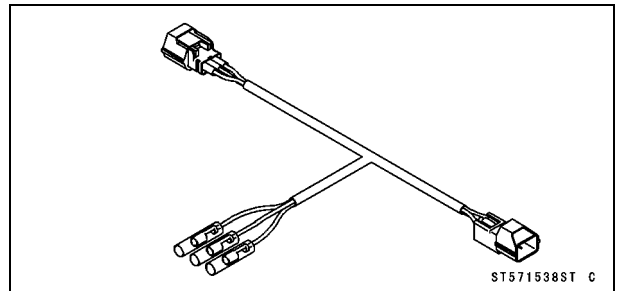

**Fork Oil Level Gauge:**  
57001-1290

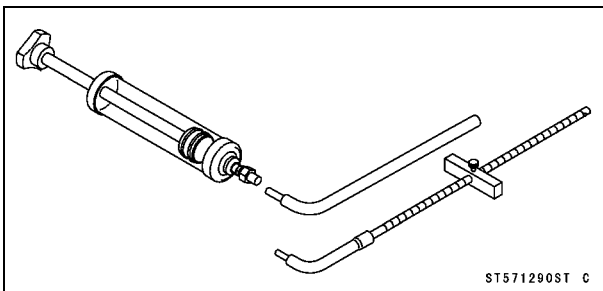

**Sensor Harness Adapter:**  
57001-1561

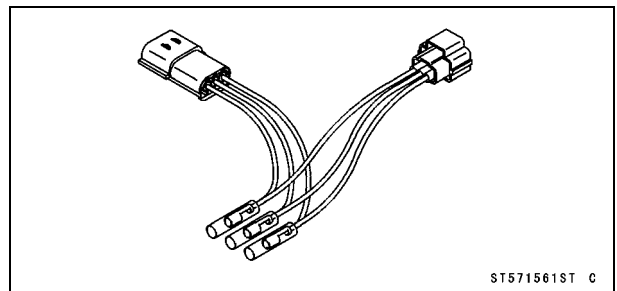

**Hand Tester:**  
57001-1394

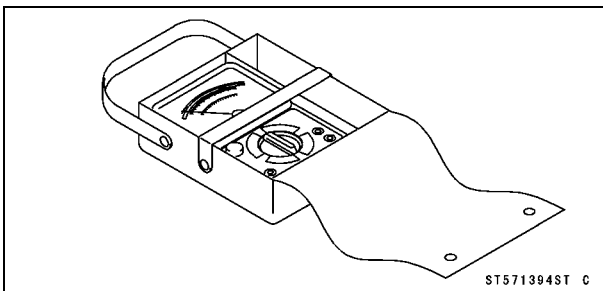

**Fuel Pressure Gauge Adapter:**  
57001-1593

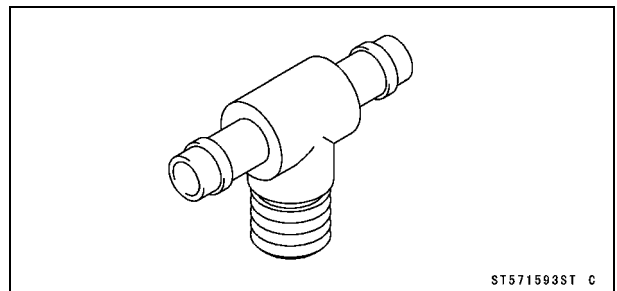

**Throttle Sensor Setting Adapter #1:**  
57001-1400

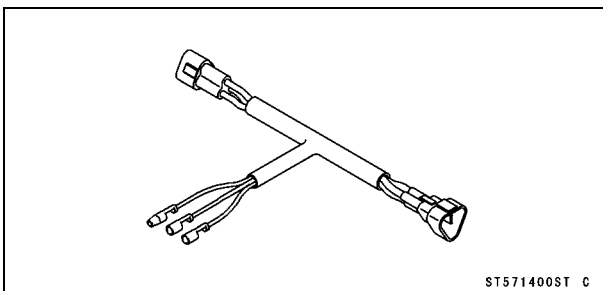

**Fuel Hose:**  
57001-1607

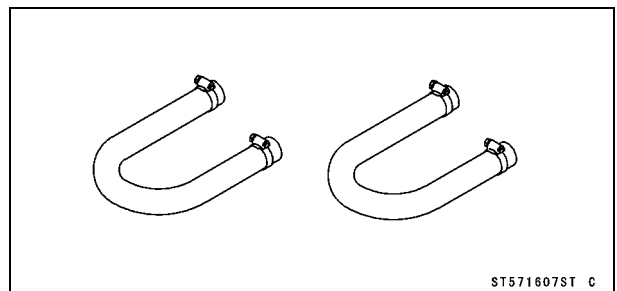

---

**Special Tools and Sealant**

---

**Kawasaki Bond (Silicone Sealant):  
56019-120**

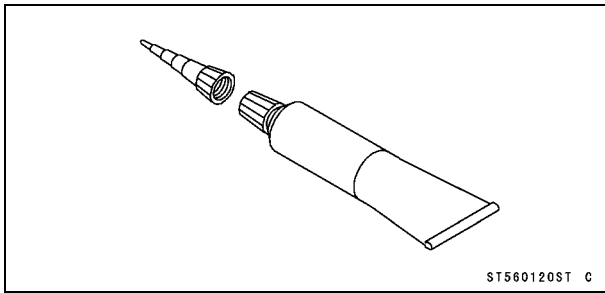

## 3-14 FUEL SYSTEM (DFI)

### DFI Parts Location

Inlet Air Pressure Sensor [A]  
Inlet Air Temperature Sensor [B]  
Nozzle Assy [C]  
Fuel Pump [D]

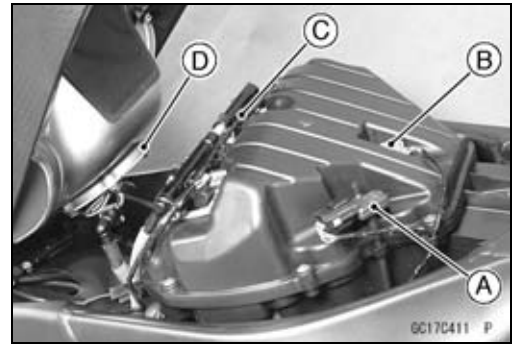

Air Switching Valve [A]  
Subthrottle Valve Actuator [B]  
Stick Coils #1, #2, #3, #4 [C]  
Throttle Body Assy [D]

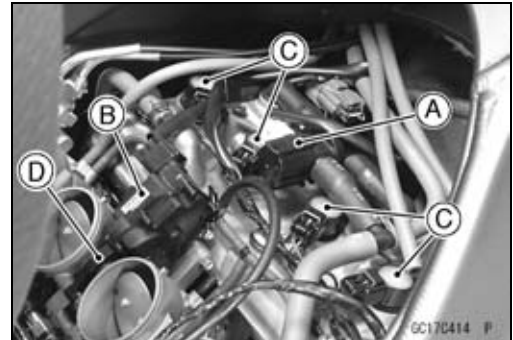

Subthrottle Sensor [A]  
Main Throttle Sensor [B]  
Water Temperature Sensor [C]

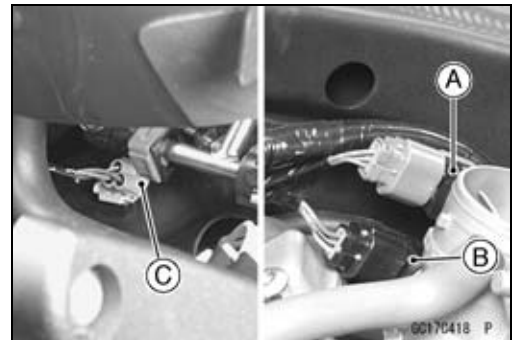

Battery [A]  
Kawasaki Self-Diagnosis System (KDS) Connector [B]  
Exhaust Butterfly Valve Actuator [C]  
Atmospheric Pressure Sensor [D]  
ECU (Electronic Control Unit) [E]

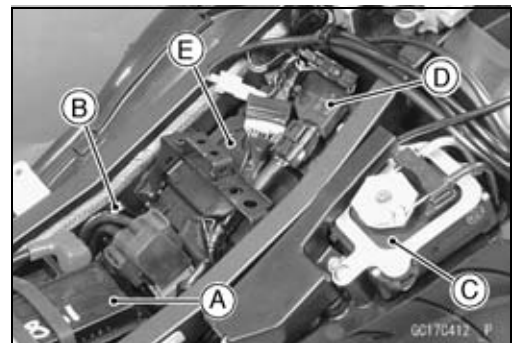

Exhaust Butterfly Valve [A]

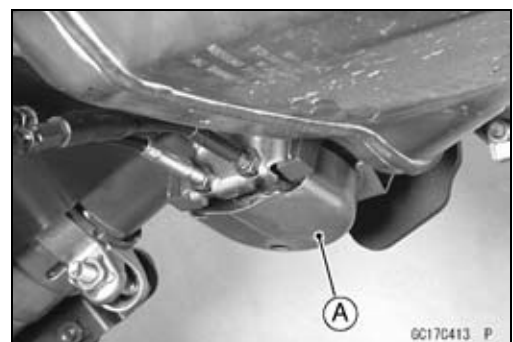



DFI Parts Location

Camshaft Position Sensor [A]  
Crankshaft Sensor [B]

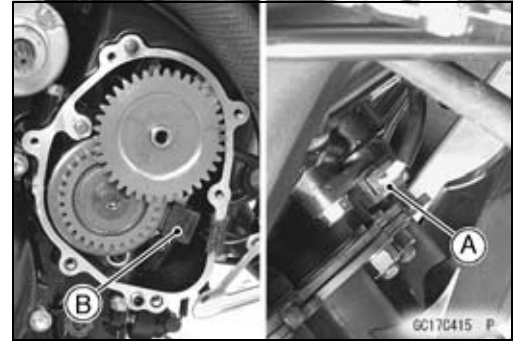

Gear Position Switch [A]  
Speed Sensor [B]

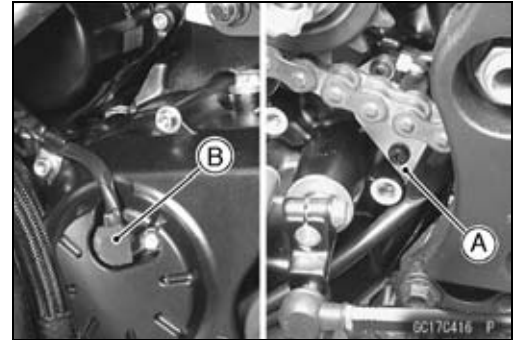

Fuse Box with ECU Main Fuse [A]  
Relay Box [B]

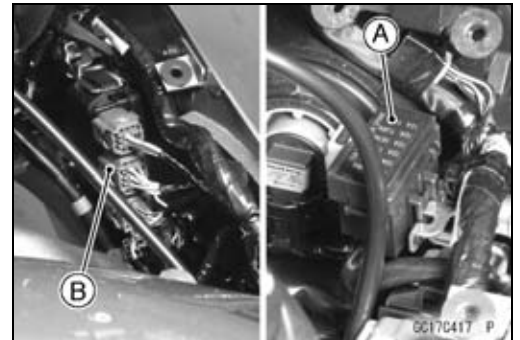

Ignition Key [A] (Transponder, Equipped Models)  
Immobilizer Antenna [B] (Equipped Models)  
Ignition Switch [C]  
Immobilizer Amplifier [D] (Equipped Models)  
Vehicle-down Sensor [E]

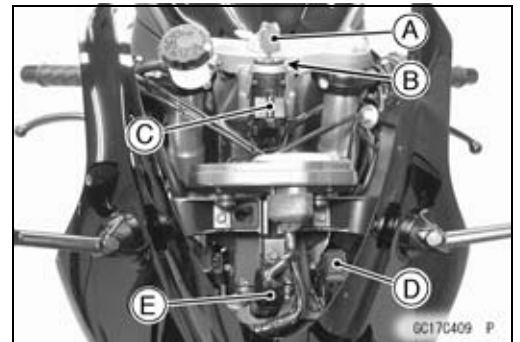

Oxygen Sensor [A] (Equipped Models)



# 3-16 FUEL SYSTEM (DFI)

## DFI System

## DFI System

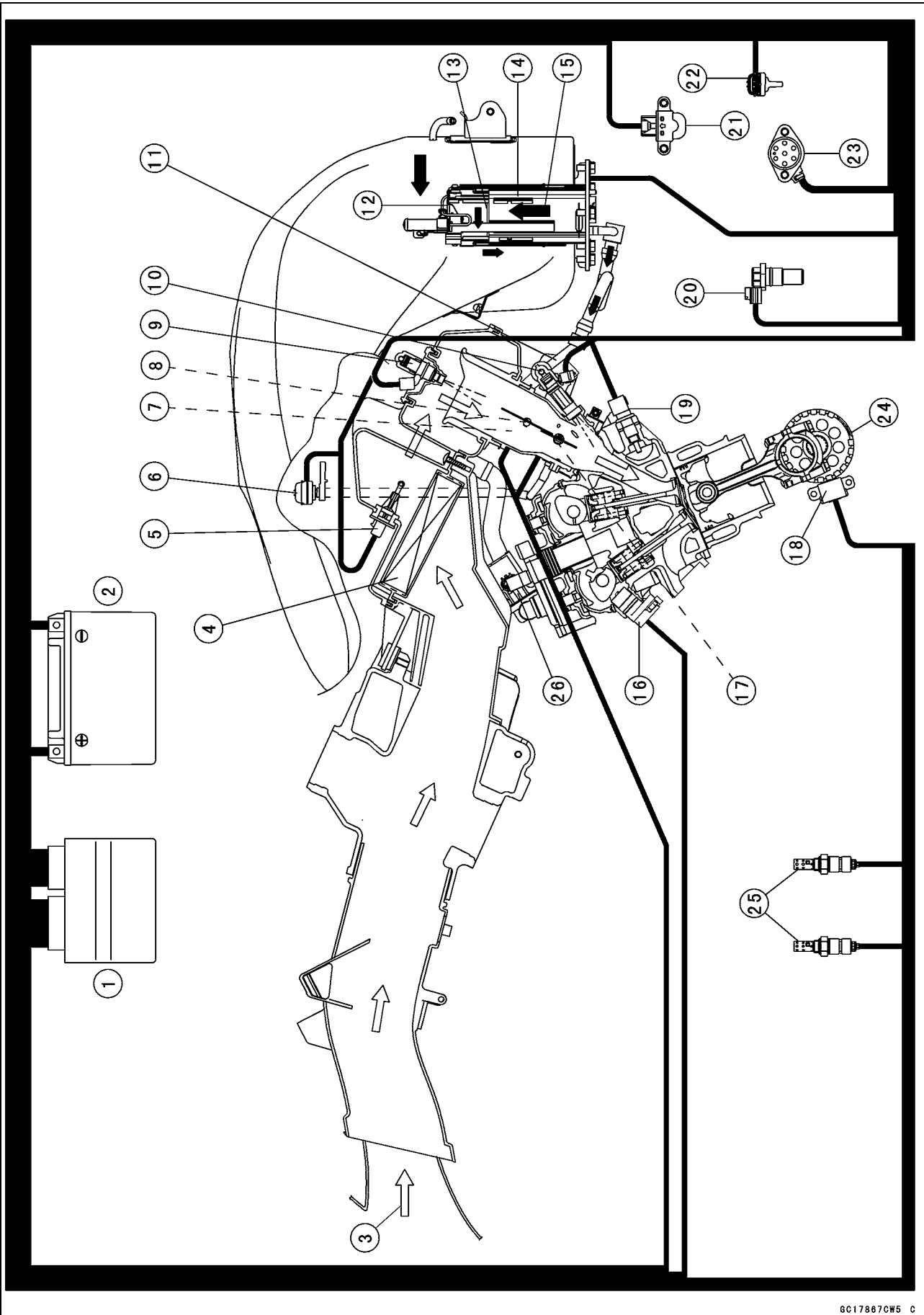

### DFI System

---

1. ECU (Electrical Control Unit)
2. Battery 12 V 8 Ah
3. Air Flow
4. Air Cleaner Element
5. Inlet Air Temperature Sensor
6. Inlet Air Pressure Sensor
7. Subthrottle Valve Actuator
8. Subthrottle Sensor
9. Secondary Fuel Injectors
10. Primary Fuel Injectors
11. Delivery Pipe
12. Fuel Filter
13. Pressure Regulator
14. Fuel Pump
15. Fuel Flow
16. Camshaft Position Sensor
17. Main Throttle Sensor
18. Crankshaft Sensor
19. Water Temperature Sensor
20. Speed Sensor
21. Vehicle-down Sensor
22. Atmospheric Pressure Sensor
23. Gear Position Switch
24. Starter Clutch Case
25. Oxygen Sensors (Equipped Models)
26. Air Switching Valve



---

**DFI System**

---

**Part Name**

1. Ignition Switch
2. Warning Indicator Light (LED)
3. Joint Connector C
4. Oxygen Sensor Fuse 10 A
5. ECU Fuse 10 A
6. Ignition Fuse 10 A
7. ECU Main Relay
8. Fuel Pump Relay
9. Relay Box
10. Joint Connector B
11. Main Fuse 30 A
12. Frame Ground
13. Battery 12 V 8 Ah
14. Fuel Pump
15. Vehicle-down Sensor
16. Kawasaki Self-diagnostic System (KDS) Connector
17. Engine Stop Switch
18. Starter Button
19. Oxygen Sensor (#1, Equipped Models)
20. Oxygen Sensor (#2, Equipped Models)
21. Cylinder Head Cover Ground
22. Spark Plugs
23. Stick Coils #1, #2, #3, #4
24. Primary Fuel Injectors
25. Secondary Fuel Injectors
26. Subthrottle Valve Actuator
27. Water Temperature Sensor
28. Speed Sensor
29. Camshaft Position Sensor
30. Atmospheric Pressure Sensor
31. Inlet Air Temperature Sensor
32. Subthrottle Sensor
33. Main Throttle Sensor
34. Inlet Air Pressure Sensor
35. Exhaust Butterfly Valve Actuator
36. Gear Position Switch
37. Crankshaft Sensor
38. ECU (Electronic Control Unit)
39. Immobilizer Antenna (Equipped Models)
40. Immobilizer Amplifier (Equipped Models)

## 3-20 FUEL SYSTEM (DFI)

### DFI System

#### Terminal Numbers of ECU Connectors

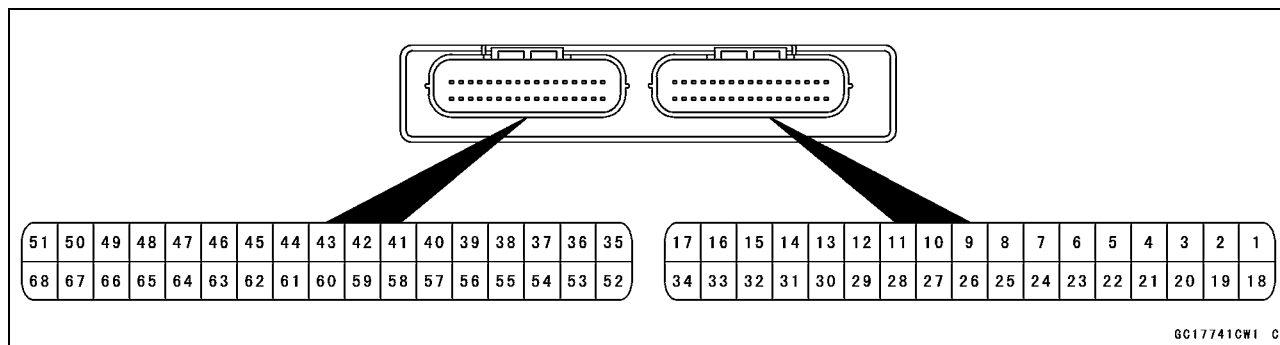

#### Terminal Names

1. Subthrottle Valve Actuator Drive Signal 3
2. Subthrottle Valve Actuator Drive Signal 1
3. Exhaust Butterfly Valve Actuator (-)
4. Exhaust Butterfly Valve Actuator (+)
5. Exhaust Butterfly Valve Sensor
6. Speed Sensor Output Signal
7. Main Throttle Sensor Output Signal
8. Inlet Air Pressure Sensor Output Signal
9. Water Temperature Sensor Output Signal
10. Power Supply to Sensors
11. Vehicle-down Sensor Output Signal
12. Camshaft Position Sensor Output Signal (+)
13. Crankshaft Sensor Output Signal (+)
14. Immobilizer Communication Line (Equipped Models)
15. Immobilizer Communication Line (Equipped Models)
16. Power Supply to ECU (from ECU Main Relay)
17. Power Supply to ECU (from Battery)
18. Subthrottle Valve Actuator Drive Signal 4
19. Subthrottle Valve Actuator Drive Signal 2
20. Unused
21. Unused
22. Unused
23. Unused
24. Subthrottle Sensor Output Signal
25. Atmospheric Pressure Sensor Output Signal
26. Inlet Air Temperature Sensor Output Signal
27. Unused
28. Ground to Sensors
29. Camshaft Position Sensor Output Signal (-)
30. Crankshaft Sensor Output Signal (-)
31. Immobilizer Communication Line
32. Unused
33. Unused
34. Ground to ECU
35. Oxygen Sensor #1 Output Signal (Equipped Models)
36. Unused
37. Detect the Engine Stop Switch off Signal
38. Starter Lockout Switch Output Signal
39. Starter Button Output Signal
40. Meter Communication Signal
41. Ground
42. Fuel Pump Relay Drive Signal
43. Unused
44. Radiator Fan Drive Signal
45. Secondary Fuel Injector #2 Drive Signal
46. Secondary Fuel Injector #1 Drive Signal
47. Primary Fuel Injector #2 Drive Signal
48. Primary Fuel Injector #1 Drive Signal
49. Stick Coil #3 Ignite Signal
50. Stick Coil #2 Ignite Signal
51. Stick Coil #1 Ignite Signal
52. Oxygen Sensor #2 Output Signal (Equipped Models)
53. Gear Position Switch Output Signal
54. Side Stand Switch Signal
55. Unused
56. External Communication Line (Mode Switch)
57. Unused
58. Power Supply to Oxygen Sensor
59. Tachometer Output Signal
60. Air Switching Valve Drive Signal
61. Unused
62. Secondary Fuel Injector #4 Drive Signal
63. Secondary Fuel Injector #3 Drive Signal
64. Primary Fuel Injector #4 Drive Signal
65. Primary Fuel Injector #3 Drive Signal
66. Ground for Fuel System
67. Ground for Ignition System
68. Stick Coil #4 Ignite Signal

## DFI Servicing Precautions

There are a number of important precautions that should be followed servicing the DFI system.

- This DFI system is designed to be used with a 12 V sealed battery as its power source. Do not use any other battery except for a 12 V sealed battery as a power source.
- Do not reverse the battery cable connections. This will damage the ECU.
- To prevent damage to the DFI parts, do not disconnect the battery cables or any other electrical connections when the ignition switch is ON, or while the engine is running.
- Take care not to short the leads that are directly connected to the battery positive (+) terminal to the chassis ground.
- When charging, remove the battery from the motorcycle. This is to prevent ECU damage by excessive voltage.
- Whenever the DFI electrical connections are to be disconnected, first turn off the ignition switch. Conversely, make sure that all the DFI electrical connections are firmly reconnected before starting the engine.
- Connect these connectors until they click [A].

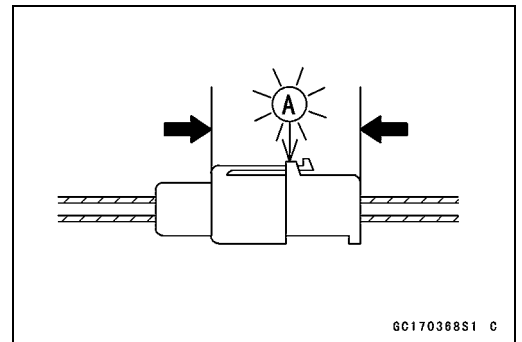

- Do not turn the ignition switch ON while any of the DFI electrical connectors are disconnected. The ECU memorizes service codes.
- Do not spray water on the electrical parts, DFI parts, connectors, leads, and wiring.
- If a transceiver is installed on the motorcycle, make sure that the operation of the DFI system is not influenced by electric wave radiated from the antenna. Check operation of the system with the engine at idle. Locate the antenna as far as possible away from the ECU.
- When any fuel hose is disconnected, do not turn on the ignition switch. Otherwise, the fuel pump will operate and fuel will spout from the fuel hose.
- Do not operate the fuel pump if the pump is completely dry. This is to prevent pump seizure.
- Before removing the fuel system parts, blow the outer surfaces of these parts clean with compressed air.
- When any fuel hose is disconnected, fuel may spout out by residual pressure in the fuel line. Cover the hose joint with a piece of clean cloth to prevent fuel spillage.
- When installing the fuel hoses, avoid sharp bending, kinking, flattening or twisting, and route the fuel hoses with a minimum of bending so that the fuel flow will not be obstructed.
- Route the hoses according to Cable, Wire, and Hose Routing section in the Appendix chapter.

## 3-22 FUEL SYSTEM (DFI)

### DFI Servicing Precautions

- Replace the fuel hose [A] if it has been sharply bent or kinked.
- The motorcycle is not properly handled, the high pressure inside the fuel line can cause fuel to leak or the hose to burst. Bend and twist the fuel hose while examining it.
- ★ Replace the hose if any cracks or bulges are noticed.

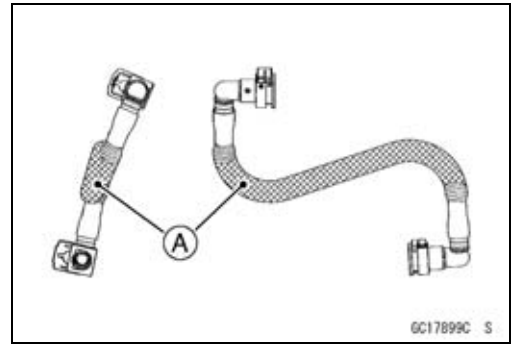

- To maintain the correct fuel/air mixture (F/A), there must be no inlet air leaks in the DFI system. Be sure to install the oil filler plug [A] after filling the engine oil.

**Torque - Oil Filler Plug: 1.5 N·m (0.15 kgf·m, 13 in·lb)**

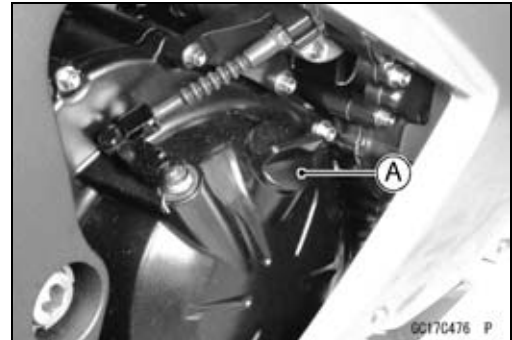



**Troubleshooting the DFI System**

The warning indicator light (LED) [A] is used for the FI indicator, immobilizer indicator (immobilizer models) and oil pressure warning indicator.

**Outline**

When a problem occurs with DFI system, the warning indicator light (LED) [A] and FI warning symbol [B] blinks to alert the rider. In addition, the condition of the problem is stored in the memory of the ECU. For models equipped with an immobilizer system, the warning indicator light (LED) and immobilizer warning symbol [C] blinks, when a problem occurs in the system.

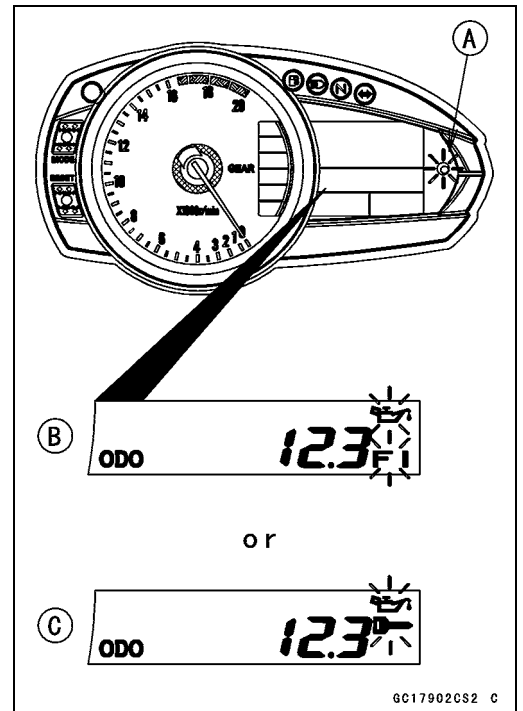
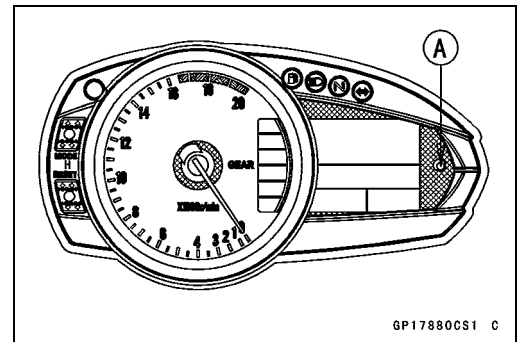

With the engine stopped and turned in the self-diagnosis mode, the service code [A] is displayed on the LCD (Liquid Crystal Display) by the number of two digits.

If the problem is with the following parts, the ECU can not recognize these problem. Therefore, the warning indicator light (LED), FI and/or immobilizer warning symbols do not blinks, and service code is not displayed.

- LCD for Meter Unit
- Fuel Pump
- Secondary Fuel Injectors
- Stick Coil Secondary Wiring and Ground Wiring
- ECU Power Source Wiring and Ground Wiring

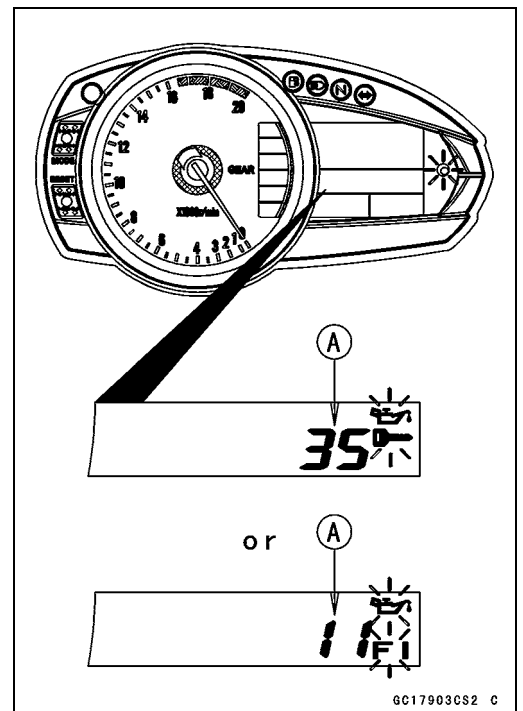

## 3-24 FUEL SYSTEM (DFI)

### Troubleshooting the DFI System

When the service code [A] is displayed, for first ask the rider about the conditions [B] of trouble, and then start to determine the cause [C] of problem.

As a pre-diagnosis inspection, check the ECU for ground and power supply, the fuel line for no fuel leaks, and for correct pressure. The pre-diagnosis items are not indicated by the warning indicator light (LED) and FI warning symbol.

Don't rely solely on the DFI self-diagnosis function, use common sense.

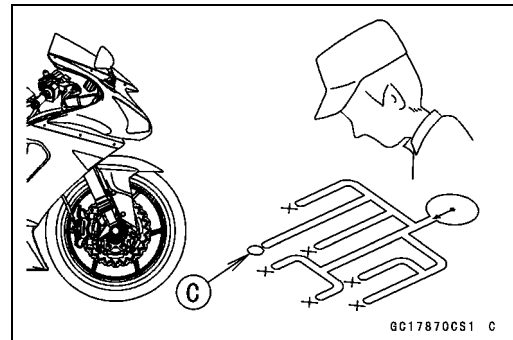
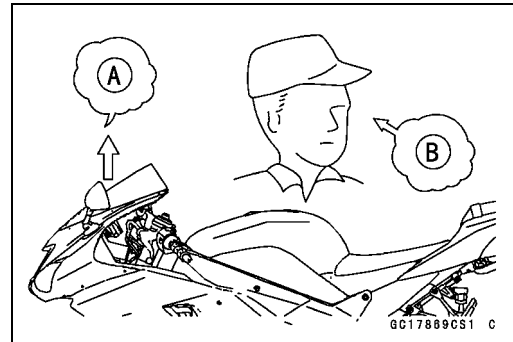

Even when the DFI system is operating normally, the warning indicator light (LED) and FI warning symbol may blink under strong electrical interference. Additional measures are not required. Turn the ignition switch OFF to stop the indicator light (LED) and symbol.

If the warning indicator light (LED) and FI warning symbol of the motorcycle brought in for repair still blinks, check the service code.

When the repair has been done, the FI warning symbol goes off. But the service codes stored in memory of the ECU are not erased to preserve the problem history. The problem history can be referred using the KDS (Kawasaki Diagnostic System) when solving unstable problems.

When the motorcycle is down, the vehicle-down sensor is turned OFF and the ECU shuts off the fuel pump relay, fuel injectors and ignition system. The ignition switch is left ON. If the starter button is pushed, the electric starter turns but the engine does not start. When the starter button is pushed, the warning indicator light (LED) and FI warning symbol blink but the service code is not displayed. To start the engine again, raise the motorcycle, turn the ignition switch OFF, and then ON.

Much of the DFI system troubleshooting work consists of confirming continuity of the wiring. The DFI parts are assembled and adjusted with precision, and it is impossible to disassemble or repair them.

**Troubleshooting the DFI System**

- When checking the DFI parts, use a digital meter which can be read two decimal place voltage or resistance.
- The DFI part connectors [A] have seals [B], including the ECU. When measuring the input or output voltage with the connector joined, use the needle adapter set [C]. Insert the needle adapter inside the seal until the needle adapter reaches the terminal.

**Special Tool - Needle Adapter Set: 57001-1457**

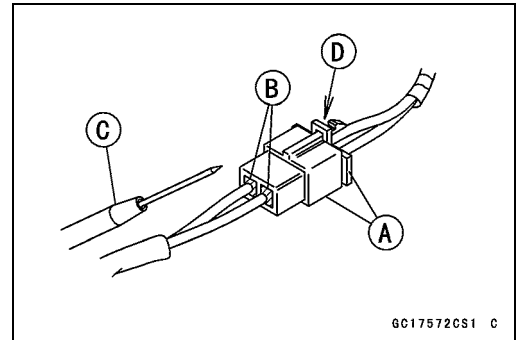

**CAUTION**

**Insert the needle adapter straight along the terminal in the connector to prevent short-circuit between terminals.**

- Make sure that measuring points are correct in the connector, noting the position of the lock [D] and the lead color before measurement. Do not reverse connections of a digital meter.
- Be careful not to short-circuit the leads of the DFI or electrical system parts by contact between adapters.
- Turn the ignition switch ON and measure the voltage with the connector joined.

**CAUTION**

**Incorrect, reverse connection or short circuit by needle adapters could damage the DFI or electrical system parts.**

- After measurement, remove the needle adapters and apply silicone sealant to the seals [A] of the connector [B] for waterproofing.

**Sealant - Kawasaki Bond (Silicone Sealant): 56019-120**

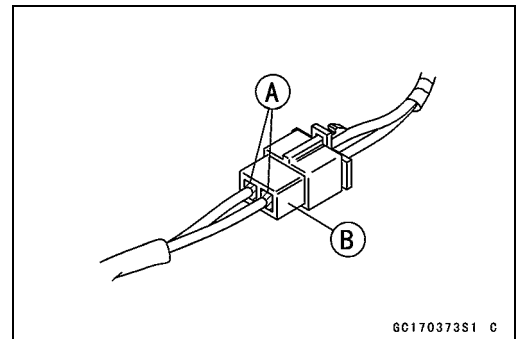

- Always check battery condition before replacing the DFI parts. A fully charged battery is a must for conducting accurate tests of the DFI system.
- Trouble may involve one or in some cases all items. Never replace a defective part without determining what CAUSED the problem. If the problem was caused by some other item or items, they too must be repaired or replaced, or the new replacement part will soon fail again.
- Measure coil winding resistance when the DFI part is cold (at room temperature).
- Make sure all connectors in the circuit are clean and tight, and examine wires for signs of burning, fraying, short, etc. Deteriorated wires and bad connections can cause reappearance of problems and unstable operation of the DFI system.
- ★ If any wiring is deteriorated, replace the wiring.

## 3-26 FUEL SYSTEM (DFI)

### Troubleshooting the DFI System

- Pull each connector [A] apart and inspect it for corrosion, dirt, and damage.
- ★ If the connector is corroded or dirty, clean it carefully. If it is damaged, replace it. Connect the connectors securely.
- Check the wiring for continuity.
- Use the wiring diagram to find the ends of the lead which is suspected of being a problem.
- Connect the hand tester between the ends of the leads.
- Set the tester to the  $\times 1 \Omega$  range, and read the tester.
- ★ If the tester does not read  $0 \Omega$ , the lead is defective. Replace the lead or the main harness or the sub harness.

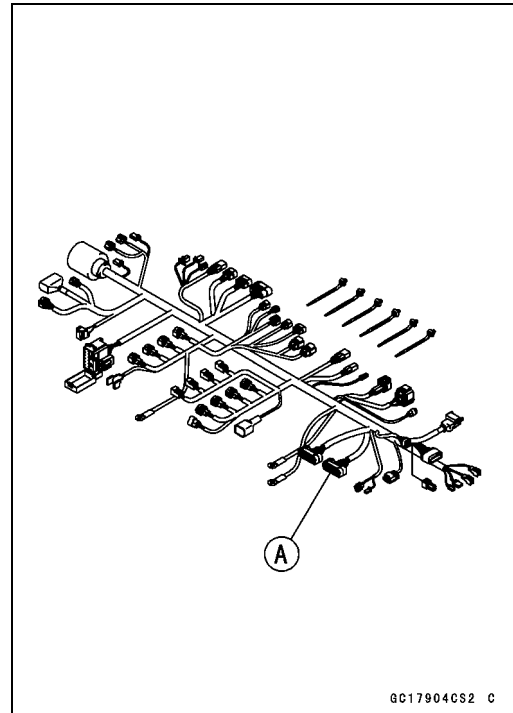

- If both ends of a harness [A] are far apart, ground [B] the one end [C], using a jumper lead [D] and check the continuity between the end [E] and the ground [F]. This enables to check a long harness for continuity. If the harness is open, repair or replace the harness.

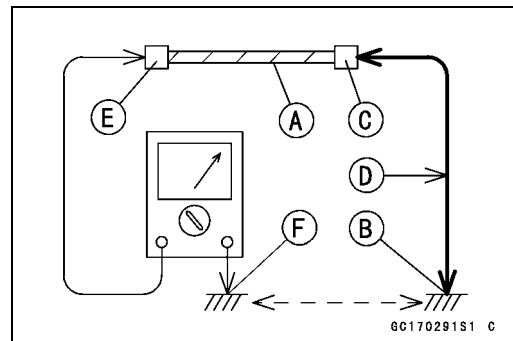

- When checking a harness [A] for short circuit, open one end [B] and check the continuity between the other end [C] and ground [D]. If there is continuity, the harness has a short circuit to ground, and it must be repaired or replaced.

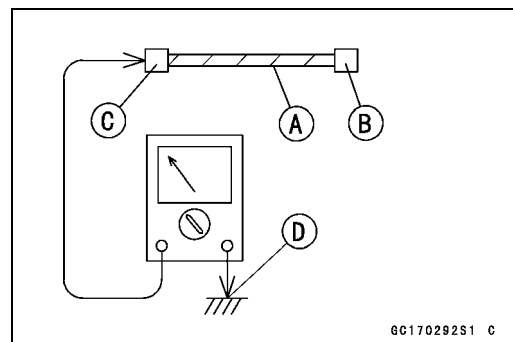

- Narrow down suspicious locations by repeating the continuity tests from the ECU connectors.
- ★ If no abnormality is found in the wiring or connectors, the DFI parts are the next likely suspects. Check the part, starting with input and output voltages. However, there is no way to check the ECU itself.
- ★ If an abnormality is found, replace the affected DFI part.
- ★ If no abnormality is found in the wiring, connectors, and DFI parts, replace the ECU.
- After inspection, be sure to connect all the DFI electrical connectors. Do not turn the ignition switch ON while the DFI electrical connectors and ignition system connectors are disconnected. Otherwise, the ECU memorizes service codes as open circuit.

**Troubleshooting the DFI System**

○Lead Color Codes:

BK: Black	G: Green	P: Pink
BL: Blue	GY: Gray	PU: Purple
BR: Brown	LB: Light Blue	R: Red
CH: Chocolate	LG: Light Green	W: White
DG: Dark Green	O: Orange	Y: Yellow

**DFI Diagnosis Flow Chart**

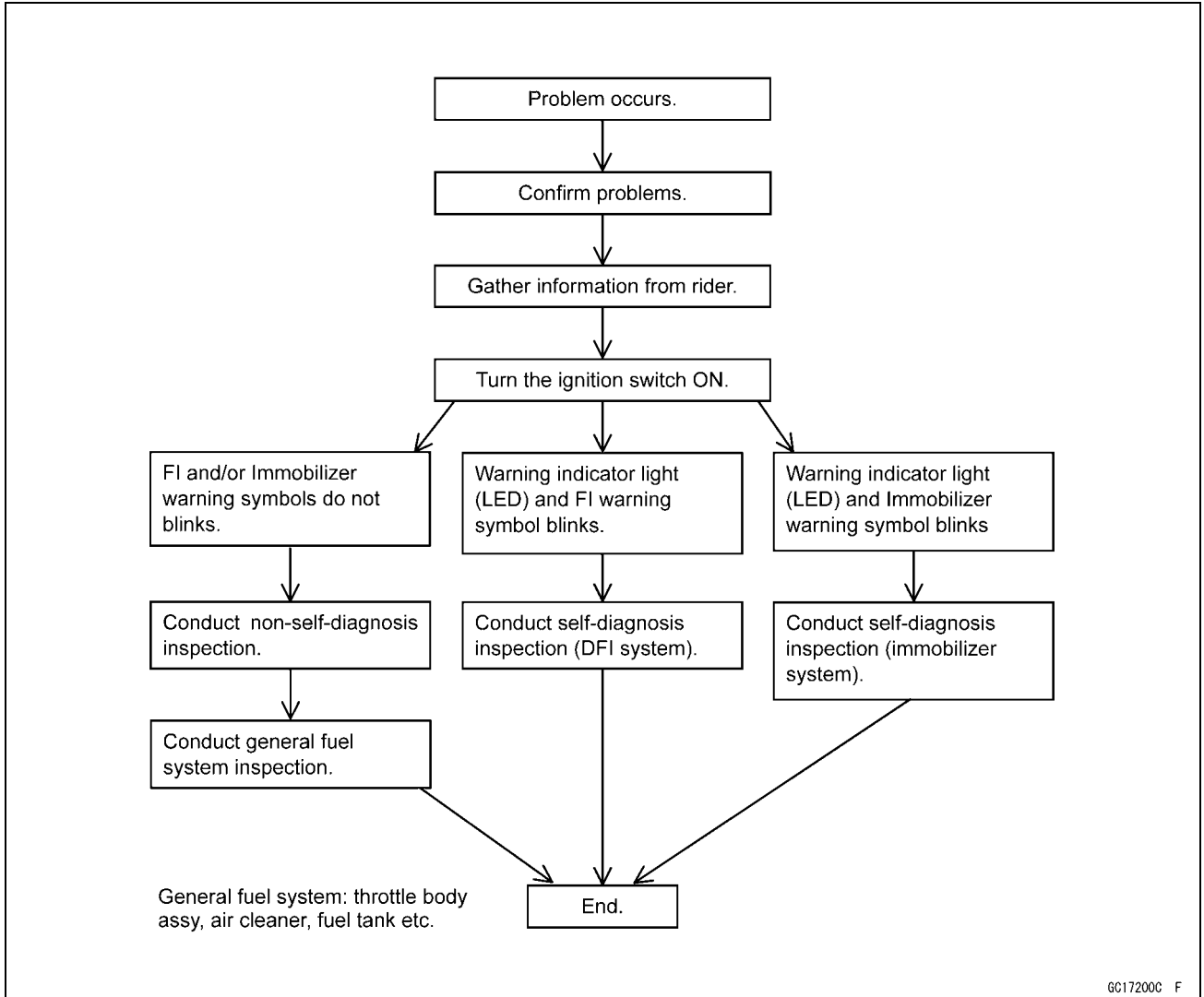

**Inquiries to Rider**

- Each rider reacts to problems in different ways, so it is important to confirm what kind of symptoms the rider has encountered.
- Try to find out exactly what problem occurred under exactly what conditions by asking the rider; knowing this information may help you reproduce the problem.
- The following sample diagnosis sheet will help prevent you from overlooking any areas, and will help you decide if it is a DFI system problem, or a general engine problem.

# 3-28 FUEL SYSTEM (DFI)

## Troubleshooting the DFI System

### Sample Diagnosis Sheet

Rider name:	Registration No. (license plate No.):	Year of initial registration:
Model:	Engine No.:	Frame No.:
Date problem occurred:	Mileage:	
<b>Environment when problem occurred.</b>		
Weather	<input type="checkbox"/> fine, <input type="checkbox"/> cloudy, <input type="checkbox"/> rain, <input type="checkbox"/> snow, <input type="checkbox"/> always, <input type="checkbox"/> other:	
Temperature	<input type="checkbox"/> hot, <input type="checkbox"/> warm, <input type="checkbox"/> cold, <input type="checkbox"/> very cold, <input type="checkbox"/> always, <input type="checkbox"/> other:	
Problem frequency	<input type="checkbox"/> chronic, <input type="checkbox"/> often, <input type="checkbox"/> once	
Road	<input type="checkbox"/> street, <input type="checkbox"/> highway, <input type="checkbox"/> mountain road ( <input type="checkbox"/> uphill, <input type="checkbox"/> downhill), <input type="checkbox"/> bumpy, <input type="checkbox"/> pebble	
Altitude	<input type="checkbox"/> normal, <input type="checkbox"/> high (about 1 000 m or more)	
<b>Motorcycle conditions when problem occurred.</b>		
FI indicator light (LED)	<input type="checkbox"/> lights up immediately after ignition switch ON, and goes off after 1 ~ 2 seconds (normal).	
	<input type="checkbox"/> lights up immediately after ignition switch ON, and stays on (DFI problem).	
	<input type="checkbox"/> lights up immediately after ignition switch ON, and blinks (immobilizer system problem).	
	<input type="checkbox"/> lights up immediately after ignition switch ON, but goes off after about 10 seconds (DFI problem).	
	<input type="checkbox"/> unlights (light (LED), ECU or its wiring fault).	
	<input type="checkbox"/> sometimes lights up (probably wiring fault).	
Starting difficulty	<input type="checkbox"/> starter motor not rotating.	
	<input type="checkbox"/> starter motor rotating but engine doesn't turn over.	
	<input type="checkbox"/> starter motor and engine don't turn over.	
	<input type="checkbox"/> no fuel flow ( <input type="checkbox"/> no fuel in tank, <input type="checkbox"/> no fuel pump sound).	
	<input type="checkbox"/> no spark.	
	<input type="checkbox"/> choke lever is not pulled fully when using the lever (pull it fully when using).	
	<input type="checkbox"/> other:	
Engine stalls	<input type="checkbox"/> right after starting.	
	<input type="checkbox"/> when opening throttle grip.	
	<input type="checkbox"/> when closing throttle grip.	
	<input type="checkbox"/> when moving off.	
	<input type="checkbox"/> when stopping the motorcycle.	
	<input type="checkbox"/> when cruising.	
	<input type="checkbox"/> other:	

**Troubleshooting the DFI System**

Poor running at low speed	<input type="checkbox"/> very low idle speed, <input type="checkbox"/> very high idle speed, <input type="checkbox"/> rough idle speed.
	<input type="checkbox"/> battery voltage is low (charge the battery).
	<input type="checkbox"/> spark plug loose (tighten it).
	<input type="checkbox"/> spark plug dirty, broken, or gap maladjusted (remedy it).
	<input type="checkbox"/> backfiring.
	<input type="checkbox"/> afterfiring.
	<input type="checkbox"/> hesitation when acceleration.
	<input type="checkbox"/> engine oil viscosity too high.
	<input type="checkbox"/> brake dragging.
	<input type="checkbox"/> engine overheating.
	<input type="checkbox"/> clutch slipping.
	<input type="checkbox"/> other:
Poor running or no power at high speed	<input type="checkbox"/> spark plug loose (tighten it).
	<input type="checkbox"/> spark plug dirty, broken, or gap maladjusted (remedy it).
	<input type="checkbox"/> spark plug incorrect (replace it).
	<input type="checkbox"/> knocking (fuel poor quality or incorrect, → use high-octane gasoline).
	<input type="checkbox"/> brake dragging.
	<input type="checkbox"/> clutch slipping.
	<input type="checkbox"/> engine overheating.
	<input type="checkbox"/> engine oil level too high.
	<input type="checkbox"/> engine oil viscosity too high.
<input type="checkbox"/> other:	

## 3-30 FUEL SYSTEM (DFI)

### DFI System Troubleshooting Guide

#### NOTE

- *This is not an exhaustive list, giving every possible cause for each problem listed. It is meant simply as a rough guide to assist the troubleshooting for some of the more common difficulties in DFI system.*
- *The ECU may be involved in the DFI electrical and ignition system troubles. If these parts and circuits are checked out good, be sure to check the ECU for ground and power supply. If the ground and power supply are checked good, replace the ECU.*

#### Engine Won't Turn Over

Symptoms or possible Causes	Actions (chapter)
Neutral, starter lockout or sidestand switch trouble	Inspect each switch (see chapter 16).
Immobilizer system trouble	Inspect (see chapter 3).
Vehicle-down sensor coming off	Reinstall (see chapter 3).
Vehicle-down sensor trouble	Inspect (see chapter 3).
Crankshaft sensor trouble	Inspect (see chapter 16).
Stick coil shorted or not in good contact	Inspect or Reinstall (see chapter 16).
Stick coil trouble	Inspect (see chapter 16).
Spark plug dirty, broken or gap maladjusted	Inspect and replace (see chapter 2).
Spark plug incorrect	Replace it with the correct plug (see chapter 2).
ECU ground and power supply trouble	Inspect (see chapter 3).
ECU trouble	Inspect (see chapter 3).
No or little fuel in tank	Supply fuel (see Owner's Manual).
Fuel Injector trouble	Inspect and replace (see chapter 3).
Fuel pump not operating	Inspect (see chapter 3).
Fuel pump relay trouble	Inspect and replace (see chapter 3).
Fuel filter or pump screen clogged	Inspect and replace fuel pump (see chapter 3).
Fuel pressure regulator trouble	Inspect fuel pressure and replace fuel pump (see chapter 3).
Fuel line clogged	Inspect and repair (see chapter 3).

#### Poor Running at Low Speed

Symptoms or Possible Causes	Actions (chapter)
<b>Spark weak:</b>	
Stick coil shorted or not in good contact	Inspect or Reinstall (see chapter 16).
Stick coil trouble	Inspect (see chapter 16).
Spark plug dirty, broken or gap maladjusted	Inspect and replace (see chapter 2).
Spark plug incorrect	Replace it with the correct plug (see chapter 2).
ECU trouble	Inspect (see chapter 3).
<b>Fuel/air mixture incorrect:</b>	
Little fuel in tank	Supply fuel (see Owner's Manual).
Air cleaner clogged, poorly sealed, or missing	Clean element or inspect sealing (see chapter 2).
Air duct loose	Reinstall (see chapter 3).
Throttle body assy holder loose	Reinstall (see chapter 3).
Throttle body assy dust seal damage	Replace (see chapter 3).
Fuel Injector O-ring damage	Replace (see chapter 3).
Fuel filter or pump screen clogged	Inspect and replace fuel pump (see chapter 3).



**DFI System Troubleshooting Guide**

Symptoms or Possible Causes	Actions (chapter)
Fuel pressure regulator trouble	Inspect fuel pressure and replace fuel pump (see chapter 3).
Fuel line clogged	Inspect and repair (see chapter 3).
Inlet air pressure sensor trouble	Inspect (see chapter 3).
Atmospheric pressure sensor trouble	Inspect (see chapter 3).
Water temperature sensor trouble	Inspect (see chapter 3).
Inlet air temperature sensor trouble	Inspect (see chapter 3).
Main throttle sensor trouble	Inspect (see chapter 3).
Subthrottle sensor trouble	Inspect (see chapter 3).
Subthrottle valve actuator trouble	Inspect (see chapter 3).
<b>Unstable (rough) idling:</b>	
Fuel pressure too low or too high	Inspect (see chapter 3).
Fuel Injector trouble	Inspect (see chapter 3).
Main throttle sensor trouble	Inspect (see chapter 3).
Subthrottle sensor trouble	Inspect (see chapter 3).
Subthrottle valve actuator trouble	Inspect (see chapter 3).
Engine vacuum not synchronizing	Inspect and adjust (see chapter 2).
Inlet air pressure sensor trouble	Inspect (see chapter 3).
Atmospheric pressure sensor trouble	Inspect (see chapter 3).
Water temperature sensor trouble	Inspect (see chapter 3).
Inlet air temperature sensor trouble	Inspect (see chapter 3).
<b>Engine stalls easily:</b>	
Spark plug dirty, broken or gap maladjusted	Inspect and replace (see chapter 2).
Stick coil trouble	Inspect (see chapter 16).
Camshaft position sensor trouble	Inspect (see chapter 16).
Main throttle sensor trouble	Inspect (see chapter 3).
Subthrottle sensor trouble	Inspect (see chapter 3).
Subthrottle valve actuator trouble	Inspect (see chapter 3).
Inlet air pressure sensor trouble	Inspect (see chapter 3).
Atmospheric pressure sensor trouble	Inspect (see chapter 3).
Water temperature sensor trouble	Inspect (see chapter 3).
Inlet air temperature sensor trouble	Inspect (see chapter 3).
Fuel pump trouble	Inspect (see chapter 3).
Fuel Injector trouble	Inspect (see chapter 3).
Fuel pressure too low or too high	Inspect (see chapter 3).
Fuel pressure regulator trouble	Inspect fuel pressure and replace fuel pump (see chapter 3).
Fuel line clogged	Inspect and repair (see chapter 3).
<b>Poor acceleration:</b>	
Fuel pressure too low	Inspect (see chapter 3).
Water or foreign matter in fuel	Change fuel. Inspect and clean fuel system (see chapter 3).
Fuel filter or pump screen clogged	Inspect and replace fuel pump (see chapter 3).
Fuel pump trouble	Inspect (see chapter 3).
Fuel Injector trouble	Inspect (see chapter 3).

## 3-32 FUEL SYSTEM (DFI)

### DFI System Troubleshooting Guide

Symptoms or Possible Causes	Actions (chapter)
Main throttle sensor trouble	Inspect (see chapter 3).
Subthrottle sensor trouble	Inspect (see chapter 3).
Subthrottle valve actuator trouble	Inspect (see chapter 3).
Inlet air pressure sensor trouble	Inspect (see chapter 3).
Atmospheric pressure sensor trouble	Inspect (see chapter 3).
Water temperature sensor trouble	Inspect (see chapter 3).
Inlet air temperature sensor trouble	Inspect (see chapter 3).
Spark plug dirty, broken or gap maladjusted	Inspect and replace (see chapter 2).
Stick coil trouble	Inspect (see chapter 16).
<b>Stumble:</b>	
Fuel pressure too low	Inspect (see chapter 3).
Fuel Injector trouble	Inspect (see chapter 3).
Main throttle sensor trouble	Inspect (see chapter 3).
Subthrottle sensor trouble	Inspect (see chapter 3).
Subthrottle valve actuator trouble	Inspect (see chapter 3).
Inlet air pressure sensor trouble	Inspect (see chapter 3).
Atmospheric pressure sensor trouble	Inspect (see chapter 3).
Water temperature sensor trouble	Inspect (see chapter 3).
Inlet air temperature sensor trouble	Inspect (see chapter 3).
<b>Surge:</b>	
Unstable fuel pressure	Fuel pressure regulator trouble (Inspect and replace fuel pump) or kinked fuel line (Inspect and replace fuel pump) (see chapter 3).
Fuel Injector trouble	Inspect (see chapter 3).
Water temperature sensor trouble	Inspect (see chapter 3).
<b>Backfiring when deceleration:</b>	
Spark plug dirty, broken or gap maladjusted	Inspect and replace (see chapter 2).
Fuel pressure too low	Inspect (see chapter 3).
Fuel pump trouble	Inspect (see chapter 3).
Main throttle sensor trouble	Inspect (see chapter 3).
Subthrottle sensor trouble	Inspect (see chapter 3).
Subthrottle valve actuator trouble	Inspect (see chapter 3).
Inlet air pressure sensor trouble	Inspect (see chapter 3).
Atmospheric pressure sensor trouble	Inspect (see chapter 3).
Water temperature sensor trouble	Inspect (see chapter 3).
Inlet air temperature sensor trouble	Inspect (see chapter 3).
Air switching valve trouble	Inspect and replace (see chapter 16).
Air suction valve trouble	Inspect and replace (see chapter 5).
<b>After fire:</b>	
Spark plug burned or gap maladjusted	Replace (see chapter 2).
Fuel Injector trouble	Inspect (see chapter 3).
Inlet air pressure sensor trouble	Inspect (see chapter 3).
Atmospheric pressure sensor trouble	Inspect (see chapter 3).
Water temperature sensor trouble	Inspect (see chapter 3).

**DFI System Troubleshooting Guide**

Symptoms or Possible Causes	Actions (chapter)
Inlet air temperature sensor trouble	Inspect (see chapter 3).
<b>Other:</b>	
Intermittent any DFI fault and its recovery	Check that DFI connectors are clean and tight, and examine leads for signs of burning or fraying (see chapter 3).

**Poor Running or No Power at High Speed:**

Symptoms or Possible Causes	Actions (chapter)
<b>Firing incorrect:</b>	
Stick coil shorted or not in good contact	Inspect or Reinstall (see chapter 16).
Stick coil trouble	Inspect (see chapter 16).
Spark plug dirty, broken or gap maladjusted	Inspect and replace (see chapter 2).
Spark plug incorrect	Replace it with the correct plug (see chapter 2).
ECU trouble	Inspect (see chapter 3).
<b>Fuel/air mixture incorrect:</b>	
Air cleaner clogged, poorly sealed, or missing	Clean element or inspect sealing (see chapter 2).
Air duct loose	Reinstall (see chapter 3).
Throttle body assy holder loose	Reinstall (see chapter 3).
Throttle body assy dust seal damage	Replace (see chapter 3).
Water or foreign matter in fuel	Change fuel. Inspect and clean fuel system (see chapter 3).
Fuel Injector O-ring damage	Replace (see chapter 3).
Fuel Injector clogged	Inspect and repair (see chapter 3).
Fuel line clogged	Inspect and repair (see chapter 3).
Fuel pump operates intermittently and often DFI fuse blows.	Fuel pump bearings may wear. Replace the fuel pump (see chapter 3).
Fuel pump trouble	Inspect (see chapter 3).
Inlet air pressure sensor trouble	Inspect (see chapter 3).
Cracked or obstructed inlet air pressure sensor hose	Inspect and repair or replace (see chapter 3).
Atmospheric pressure sensor trouble	Inspect (see chapter 3).
Water temperature sensor trouble	Inspect (see chapter 3).
Inlet air temperature sensor trouble	Inspect (see chapter 3).
Main throttle sensor trouble	Inspect (see chapter 3).
Subthrottle sensor trouble	Inspect (see chapter 3).
Subthrottle valve actuator trouble	Inspect (see chapter 3).
<b>Knocking:</b>	
Fuel poor quality or incorrect	Fuel charge (Use the gasoline recommended in the Owner's Manual).
Spark plug incorrect	Replace it with the correct plug (see chapter 2).
Stick coil trouble	Inspect (see chapter 16).
ECU trouble	Inspect (see chapter 3).
Engine vacuum not synchronizing	Inspect and adjust (see chapter 2).
Inlet air pressure sensor trouble	Inspect (see chapter 3).
Atmospheric pressure sensor trouble	Inspect (see chapter 3).

## 3-34 FUEL SYSTEM (DFI)

### DFI System Troubleshooting Guide

Symptoms or Possible Causes	Actions (chapter)
Water temperature sensor trouble	Inspect (see chapter 3).
Inlet air temperature sensor trouble	Inspect (see chapter 3).
<b>Miscellaneous:</b>	
Subthrottle sensor trouble	Inspect (see chapter 3).
Subthrottle valve actuator trouble	Inspect (see chapter 3).
Speed sensor trouble	Inspect (see chapter 3).
Throttle valves will not fully open	Inspect throttle cables and lever linkage (see chapter 3).
Engine overheating - Water temperature sensor, crankshaft sensor or speed sensor trouble	(see Overheating of Troubleshooting Guide in chapter 17)
Air switching valve trouble	Inspect and replace (see chapter 16).
Air suction valve trouble	Inspect and replace (see chapter 5).
<b>Exhaust Smokes Excessively:</b>	
<b>(Black smokes)</b>	
Air cleaner element clogged	Clean element (see chapter 2).
Fuel pressure too high	Inspect (see chapter 3).
Fuel Injector trouble	Inspect (see chapter 3).
Water temperature sensor trouble	Inspect (see chapter 3).
Inlet air temperature sensor trouble	Inspect (see chapter 3).
<b>(Brown smoke)</b>	
Air duct loose	Reinstall (see chapter 3).
Fuel pressure too low	Inspect (see chapter 3).
Water temperature sensor trouble	Inspect (see chapter 3).
Inlet air temperature sensor trouble	Inspect (see chapter 3).

**Self-Diagnosis**

The warning indicator light (LED) [A] is used for the FI indicator, immobilizer indicator (immobilizer models) and oil pressure warning indicator.

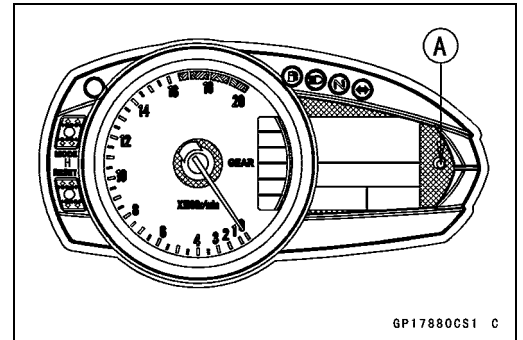

**Self-diagnosis Outline**

The self-diagnosis system has two modes and can be switched to another mode by operating the meter unit.

**User Mode**

The ECU notifies the rider of troubles in DFI system, ignition system and immobilizer system by blinking the warning indicator light (LED) [A], FI warning symbol [B] and immobilizer warning symbol [C] when DFI, ignition and immobilizer system parts are faulty, and initiates fail-safe function. In case of serious troubles ECU stops the injection/ignition/starter motor operation.

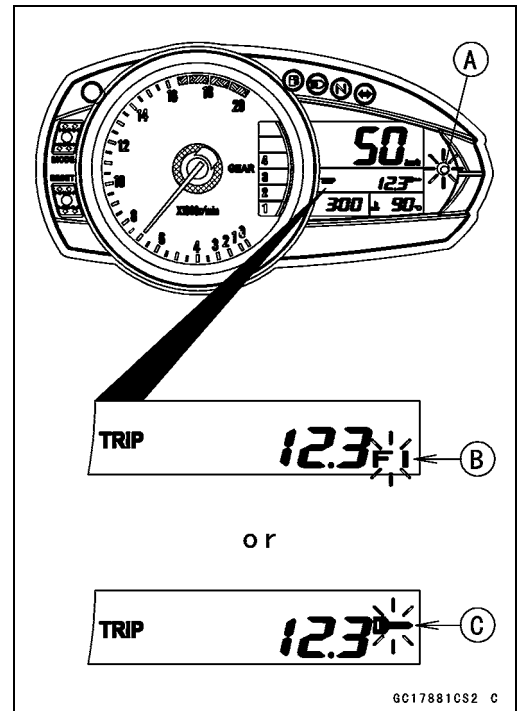

**Dealer Mode**

The LCD (Liquid Crystal Display) display the service code(s) [A] to show the problem(s) which the DFI system, ignition system and immobilizer system has at the moment of diagnosis.

Immobilizer Models [B]

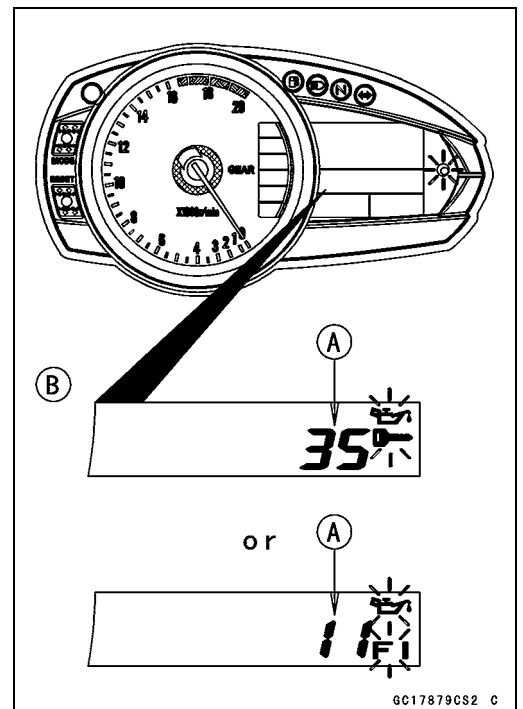

## 3-36 FUEL SYSTEM (DFI)

### Self-Diagnosis

#### Self-diagnosis Procedures

- When a problem occurs with the DFI system and ignition system, the warning indicator light (LED) [A] and FI warning symbol [B] blinks.
- For models equipped with an immobilizer system, when a problem occurs with the system, the warning indicator light (LED) and immobilizer warning symbol [C] blinks.

#### NOTE

- Use a fully charged battery when conducting self-diagnosis. Otherwise, the light (LED) and symbol blinks very slowly or do not blink.

- Turn the ignition switch ON.
- Push the MODE button [A] to display the odometer.  
Immobilizer Models [B]

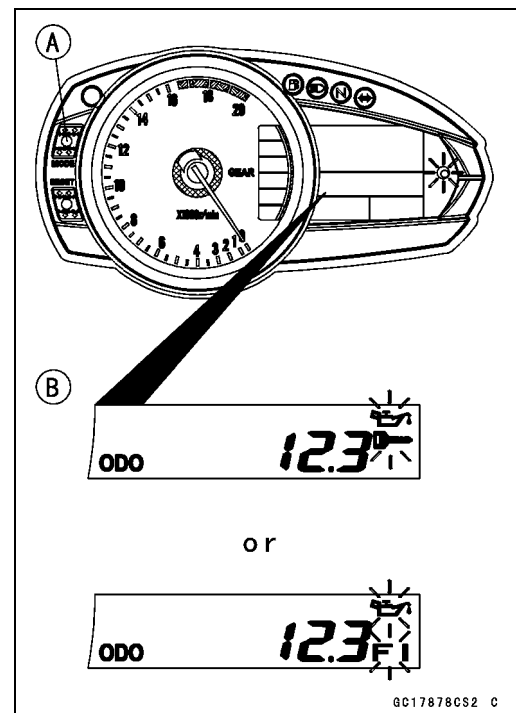
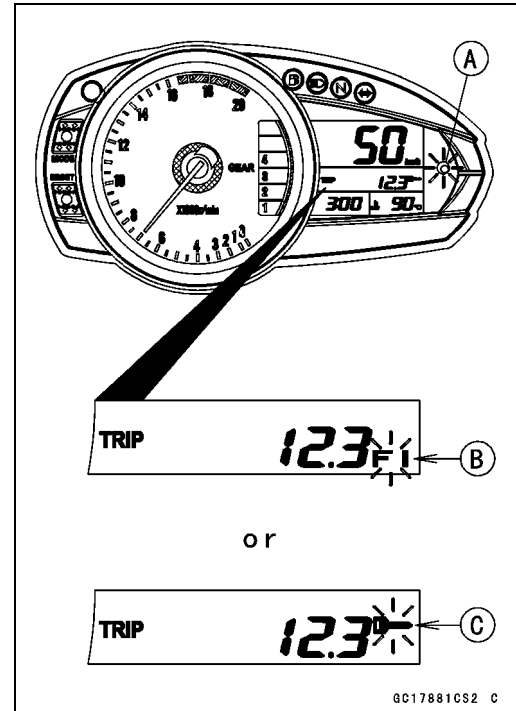

**Self-Diagnosis**

- Push the MODE button [A] for more than two seconds.
- The service code [B] is displayed on the LCD by the number of two digits.
- Immobilizer Models [C]
- Any of the following procedures ends self-diagnosis.
- When the service code is displayed on the LCD, push the MODE button for more than two seconds.
- When the ignition switch is turned OFF.

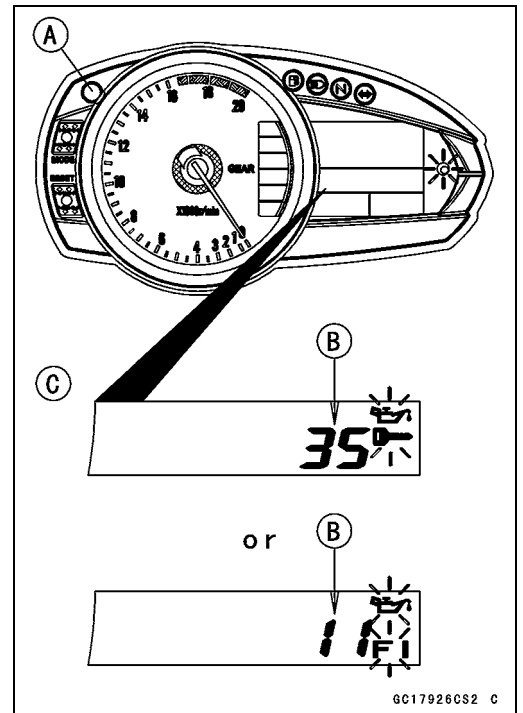

**Self-Diagnosis Flow Chart**

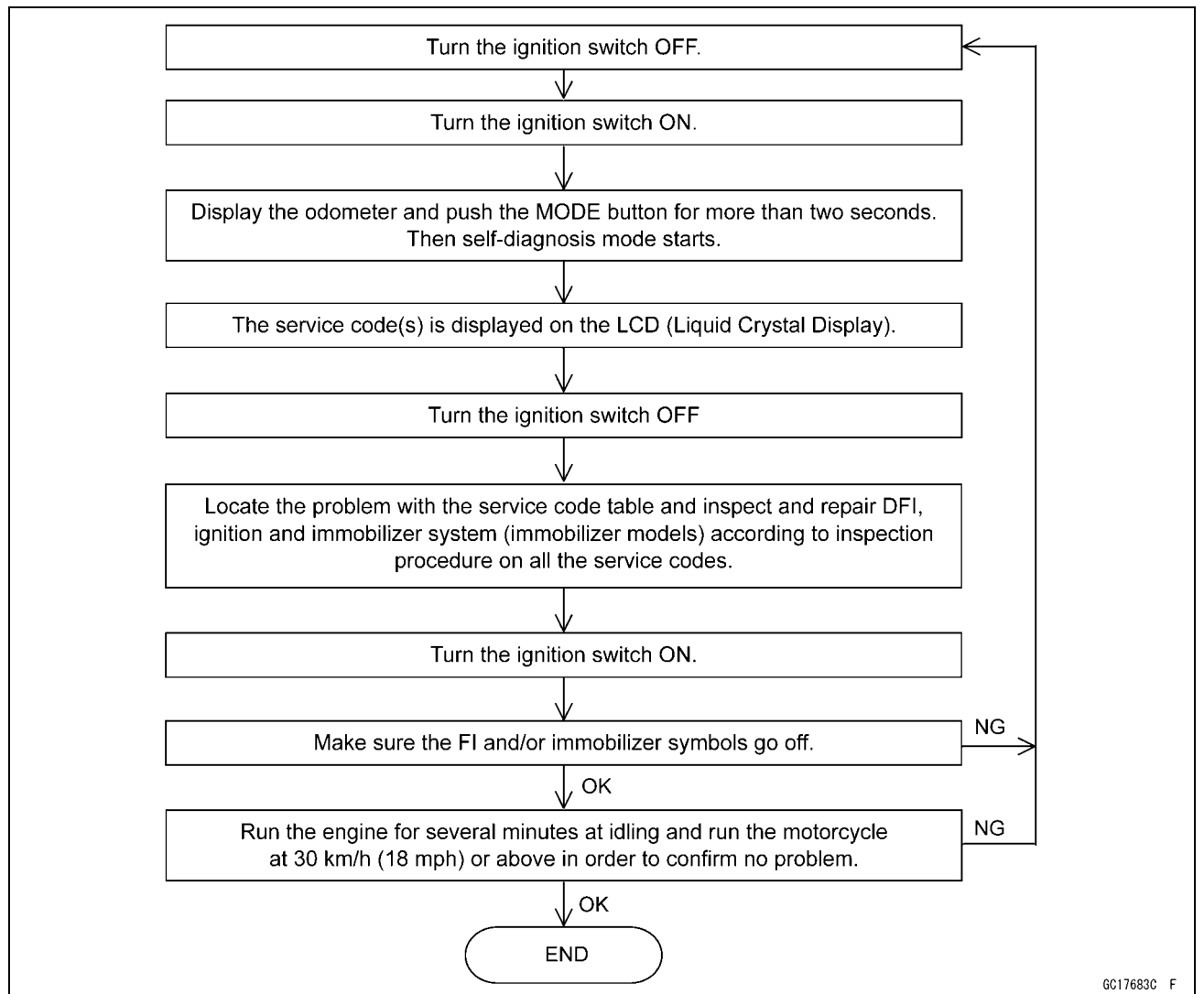

## 3-38 FUEL SYSTEM (DFI)

### Self-Diagnosis

#### Service Code Reading

- The service code(s) is displayed on the LCD by the number of two digits.
- When there are a number of problems, all the service codes can be stored and the display will begin starting from the lowest number service code in the numerical order.
- Then after completing all codes, the display is repeated until the ignition switch is turned OFF or MODE button is pushed for more than two seconds.
- For example, if three problems occurred in the order of 56, 15, 35, the service codes are displayed (each two seconds) from the lowest number in the order listed as shown below. (15→35→56)→(15→35→56)→. . .(repeated)

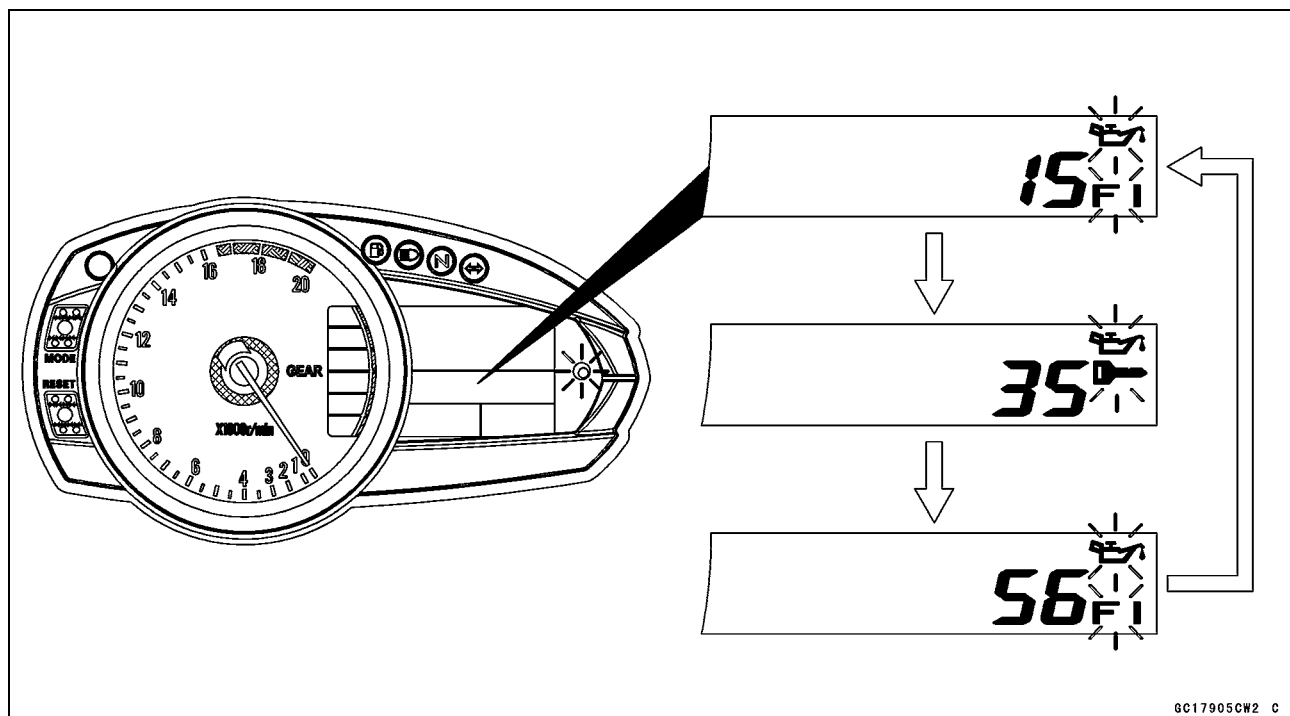

- If there is no problem or when the repair has been done, FI and/or immobilizer symbols go off and service code is not displayed.

#### Service Code Erasing

- When repair has been done, FI and/or immobilizer warning symbols go off and service code is not displayed.
- ★But the service codes stored in memory of the ECU are not erased to preserve the problem history. In this model, the problem history can not be erased.



**Self-Diagnosis**

**Service Code Table**

<b>Service Code</b>	<b>Problems</b>
11	Main throttle sensor malfunction, wiring open or short
12	Inlet air pressure sensor malfunction, wiring open or short
13	Inlet air temperature sensor malfunction, wiring open or short
14	Water temperature sensor malfunction, wiring open or short
15	Atmospheric pressure sensor malfunction, wiring open or short
21	Crankshaft sensor malfunction, wiring open or short
23	Camshaft position sensor malfunction, wiring open or short
24	Speed sensor malfunction, wiring open or short
25	Gear position switch malfunction, wiring open or short
31	Vehicle-down sensor malfunction, wiring open or short
32	Subthrottle sensor malfunction, wiring open or short
33	Oxygen sensor #1 inactivation, wiring open or short (Equipped Models)
34	Exhaust butterfly valve actuator sensor malfunction, wiring open or short
35	Immobilizer amplifier malfunction
36	Blank Key detection
39	ECU communication error
51	Stick coil #1 malfunction, wiring open or short
52	Stick coil #2 malfunction, wiring open or short
53	Stick coil #3 malfunction, wiring open or short
54	Stick coil #4 malfunction, wiring open or short
56	Radiator fan relay malfunction, wiring open or short
62	Subthrottle valve actuator malfunction, wiring open or short
63	Exhaust butterfly valve actuator malfunction, wiring open or short
64	Air switching valve malfunction, wiring open or short
67	Oxygen sensor heater malfunction, wiring open or short (Equipped Models)
83	Oxygen Sensor #2 inactivation, wiring open or shout (Equipped Models)
94	Oxygen sensor #1 malfunction, wiring open or short (Equipped Models)
95	Oxygen sensor #2 malfunction, wiring open or short (Equipped Models)

**Notes:**

- The ECU may be involved in these problems. If all the parts and circuits checked out good, be sure to check the ECU for ground and power supply. If the ground and power supply are checked good, replace the ECU.
- When no service code is displayed, the electrical parts of the DFI system has no fault, and the mechanical parts of the DFI system and the engine are suspect.

## 3-40 FUEL SYSTEM (DFI)

### Self-Diagnosis

#### Backups

○The ECU takes the following measures to prevent engine damage when the DFI, ignition or immobilizer system parts have troubles.

Service Codes	Parts	Output Signal Usable Range or Criteria	Backups by ECU
11	Main Throttle Sensor	Output Voltage 0.2 ~ 4.8 V	If the main throttle sensor system fails (the output voltage is out of the usable range, wiring short or open), the ECU locks ignition timing into the ignition timing at closed throttle position and sets the DFI in the D-J method.
12	Inlet Air Pressure Sensor	Inlet Air Pressure (Absolute) $P_v = 100 \sim 900$ mmHg	If the inlet air pressure sensor system fails (the signal is out of the usable range, wiring short or open), the ECU sets the DFI in the $\alpha$ -N method (1).
13	Inlet Air Temperature Sensor	Inlet Air Temperature $T_a = -47 \sim +178$ °C	If the inlet air temperature sensor system fails (the signal is out of the usable range, wiring short or open), the ECU sets $T_a$ at 30°C.
14	Water Temperature Sensor	Water Temperature $T_w = -30 \sim +120$ °C	If the water temperature sensor system fails (the signal is out of the usable range, wiring short or open), the ECU sets $T_w$ at 80°C. When an radiator fan is turning on, ECU sets $T_w$ at 110°C.
15	Atmospheric Pressure Sensor	Atmospheric Pressure (Absolute) $P_a = 100 \sim 900$ mmHg	If the atmospheric pressure sensor system fails (the signal is out of the usable range, wiring short or open), the ECU sets $P_a$ at 760 mmHg (the standard atmospheric pressure).
21	Crankshaft Sensor	Crankshaft sensor must send 22 signals to the ECU at the 1 cranking.	If the crankshaft sensor generates less than 22 or more signals, the engine stops by itself.
23	Camshaft Position Sensor	Camshaft position sensor must send 1 signal to the ECU at the 2 crankings.	If the camshaft position sensor system fails (the signal is missing, wiring short or open), the ECU continues to ignite cylinders in the same sequence following the last good signal.
24	Speed Sensor	Speed sensor must send 8 signals to the ECU at the one rotation of the drive shaft.	If the speed sensor system fails (no signal, wiring short or open), the speedometer shows 0.
25	Gear Position Switch	Gear Position Switch Output Voltage (signal) $V_d = 0.2 \text{ V} \sim 4.8 \text{ V}$	The ECU sets the top (6) gear position.
31	Vehicle-down Sensor	Output Voltage 0.65 ~ 4.45 V	If the vehicle-down sensor system has failures (the output voltage is out of the usable range, wiring short or open), the ECU shuts off the fuel pump relay, the fuel injectors and the ignition system.
32	Subthrottle Sensor	Output Voltage 0.15 ~ 4.85 V	If the subthrottle sensor system fails (the output voltage is out of the usable range, wiring short or open), the ECU drive the subthrottle valve to the full closed position, and it stops the current to the subthrottle valve actuator.

**Self-Diagnosis**

<b>Service Codes</b>	<b>Parts</b>	<b>Output Signal Usable Range or Criteria</b>	<b>Backups by ECU</b>
<b>33</b>	Oxygen Sensor #1 (Equipped Models)	The oxygen sensor #1 is active and sensor must send signals (output voltage) continuously to the ECU.	If the oxygen sensor is not activated, the ECU stops the feedback mode of the oxygen sensor.
<b>34</b>	Exhaust Butterfly Valve Actuator Sensor	Output Voltage 0.1 ~ 4.8 V	If the exhaust butterfly valve sensor system fails (the output voltage is out of the usable range, wiring short or open), the ECU locks the exhaust butterfly valve at full open position near, and it stops the current to the exhaust butterfly valve actuator.
<b>35</b>	Immobilizer Amplifier	–	If the immobilizer system fails (no signal, wiring short or open), the vehicle is no start and run.
<b>36</b>	Master or User Key	The user or master key must use register key.	If the blank key or broken key is used, the vehicle is no start and run.
<b>39</b>	ECU	The ECU send the data (for gear position service code and key registration) to the meter unit.	–
<b>51</b>	Stick Coil #1*	The stick coil primary winding must send signals 20 or more times continuously to the ECU.	If the stick coil #1 primary winding has failures (no signal, wiring short or open), the ECU shuts off the injector #1 to stop fuel to the cylinder #1, though the engine keeps running.
<b>52</b>	Stick Coil #2*	The stick coil primary winding must send signals 20 or more times continuously to the ECU.	If the stick coil #2 primary winding has failures (no signal, wiring short or open), the ECU shuts off the injector #2 to stop fuel to the cylinder #2, though the engine keeps running.
<b>53</b>	Stick Coil #3*	The stick coil primary winding must send signals 20 or more times continuously to the ECU.	If the stick coil #3 primary winding has failures (no signal, wiring short or open), the ECU shuts off the injector #3 to stop fuel to the cylinder #3, though the engine keeps running.
<b>54</b>	Stick Coil #4*	The stick coil primary winding must send signals 20 or more times continuously to the ECU.	If the stick coil #4 primary winding has failures (no signal, wiring short or open), the ECU shuts off the injector #4 to stop fuel to the cylinder #4, though the engine keeps running.
<b>56</b>	Radiator Fan Relay	When the relay OFF condition, the fan relay is open.	–
<b>62</b>	Subthrottle Valve Actuator	The actuator operates open and close of the subthrottle valve by the pulse signal from the ECU.	If the subthrottle actuator fails (the signal is out to the usable range, wiring short or open), the ECU stops the current to the actuator.

## 3-42 FUEL SYSTEM (DFI)

### Self-Diagnosis

Service Codes	Parts	Output Signal Usable Range or Criteria	Backups by ECU
63	Exhaust Butterfly Valve Actuator	The actuator operates open and close of the exhaust butterfly valve by the pulse signal from the ECU.	If the exhaust butterfly valve actuator fails (the signal is out to the usable range, wiring short or open), the ECU stops the current to the actuator.
64	Air Switching Valve	The air switching valve controls the flow of the secondary air by opening and shutting the solenoid valve.	—
67	Oxygen Sensor Heater (Equipped Models)	The oxygen sensor heater raise temperature of the sensor for its earlier activation. 12 V-3.6 W, 1.5 A	If the oxygen sensor heater fails (wiring short or open), the ECU stops the current to the heater, and it stops the feedback mode of the oxygen sensor.
83	Oxygen Sensor #2 (Equipped Models)	The oxygen sensor #1 is active and sensor must send signals (output voltage) continuously to the ECU.	If the oxygen sensor is not activated, the ECU stops the feedback mode of the oxygen sensor.
94	Oxygen Sensor #1 (Equipped Models)	The oxygen sensor #1 must signals (output voltage) continuously to the ECU.	If the oxygen sensor #1 output voltage is incorrect, the ECU stops oxygen sensor feed back mode, of the oxygen sensor.
95	Oxygen Sensor #2 (Equipped Models)	The oxygen sensor #1 must signals (output voltage) continuously to the ECU.	If the oxygen sensor #2 output voltage is incorrect, the ECU stops oxygen sensor feed back mode of the oxygen sensor

#### Note:

(1)  $\alpha$ -N Method: the DFI control method from medium to heavy engine load. When the engine load is light like at idling or low speed, the ECU determines the injection quantity by calculating from the throttle vacuum (inlet air pressure sensor output voltage) and engine speed (crankshaft sensor output voltage). This method is called D-J method. As the engine speed increases, and the engine load turns middle to heavy, the ECU determines the injection quantity by calculating from the throttle opening (throttle sensor output voltage) and the engine speed. This method is called  $\alpha$ -N method.

\*: This depends on the number of stopped cylinders.

## Main Throttle Sensor (Service Code 11)

The main throttle sensor is a rotating variable resistor that changes output voltage according to throttle operating. The ECU senses this voltage change and determines fuel injection quantity, and ignition timing according to engine rpm, and throttle opening.

Input Terminal [A]

Output Terminal [B]

Ground Terminal [C]

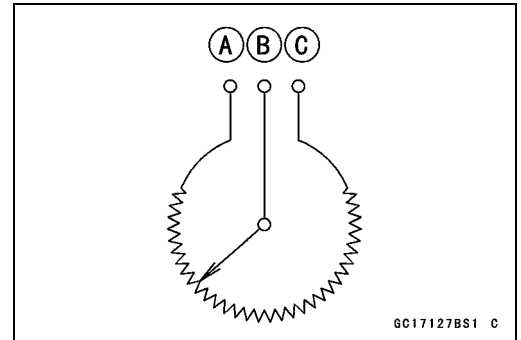

### Main Throttle Sensor Removal/Adjustment

#### CAUTION

**Do not remove or adjust the main throttle sensor since it has been adjusted and set with precision at the factory.**

**Never drop the throttle body assy, especially on a hard surface. Such a shock to the sensor can damage it.**

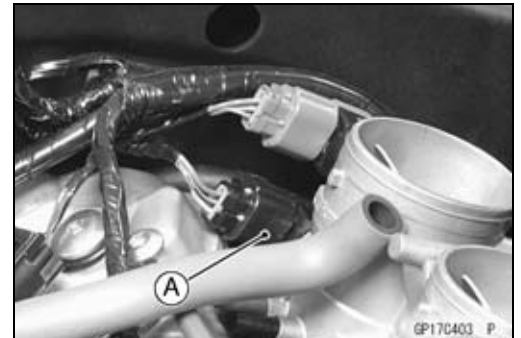

Main Throttle Sensor Connector [A]

### Main Throttle Sensor Input Voltage Inspection

#### NOTE

○Be sure the battery is fully charged.

- Turn the ignition switch OFF.
- Remove the ECU (see ECU Removal). Do not disconnect the ECU connectors.
- Connect a digital voltmeter [A] to the connectors [B], using the needle adapter set.

**Special Tool - Needle Adapter Set: 57001-1457**

#### Main Throttle Sensor Input Voltage

##### Connections to ECU Connector

Meter (+) → BL lead (terminal 10)

Meter (-) → BR/BK lead (terminal 28)

- Measure the input voltage with the engine stopped, and with the connectors joined.
- Turn the ignition switch ON.

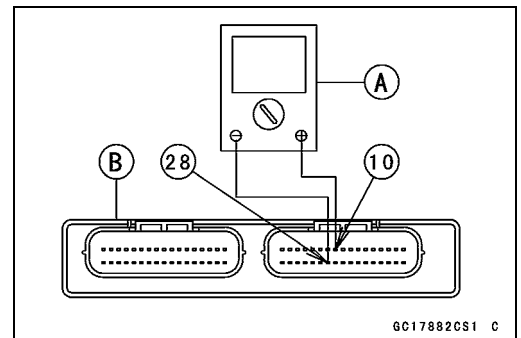

#### Input Voltage at ECU Connector

**Standard: DC 4.75 ~ 5.25 V**

- Turn the ignition switch OFF.
- ★ If the reading of input voltage is less than the standard, check the ECU for its ground, power supply and wiring shorted.
- ★ If the input voltage is within the standard range, check the input voltage at the main throttle sensor connector.
- Remove:
  - Air Cleaner Housing (see Air Cleaner Housing Removal)
  - Fuel Pump Lead Connector (see Fuel Tank Removal)

## 3-44 FUEL SYSTEM (DFI)

### Main Throttle Sensor (Service Code 11)

- Disconnect the main throttle sensor connector and connect the setting adapter [A] between the harness connector and main throttle sensor connector.

- Connect a digital meter [B] to the setting adapter leads.

**Special Tool - Throttle Sensor Setting Adapter: 57001-1538**

#### Main Throttle Sensor Input Voltage

##### Connections to Sensor

Meter (+) → BL lead

Meter (-) → BR/BK lead

- Install the throttle body assy (see Throttle Body Assy Installation).
- Measure the sensor input voltage with the engine stopped, and with the connector joined.
- Turn the ignition switch ON.

#### Input Voltage at Sensor

**Standard: DC 4.75 ~ 5.25 V**

- Turn the ignition switch OFF.
- ★ If the reading is out of the range, check the wiring (see wiring diagram).
- ★ If the reading is good, check the output voltage of the sensor.

#### Main Throttle Sensor Output Voltage Inspection

- Measure the output voltage at the ECU in the same way as input voltage inspection.

Digital Voltmeter [A]

Connectors [B]

**Special Tool - Needle Adapter Set: 57001-1457**

#### Main Throttle Sensor Output Voltage

##### Connections to ECU

Meter (+) → Y/W lead (terminal 7)

Meter (-) → BR/BK lead (terminal 28)

- Start the engine and warm it up thoroughly.
- Check idle speed to ensure throttle opening is correct.

#### Idle Speed

**Standard: 1 300 r/min (rpm)**

- ★ If the idle speed is out of the specified range, adjust the idle speed (see Idle Speed Adjustment in the Periodic Maintenance chapter).
- Turn the ignition switch OFF.
- Measure the output voltage with the engine stopped, and with the connector joined.
- Turn the ignition switch ON.
- Measure the output voltage when the throttle is fully opened or completely closed.

#### Output Voltage at ECU

**Standard: DC 1.025 ~ 1.055 V (at idle throttle opening)**

**Approximately DC 4.22 ~ 4.42 V (full throttle opening)**

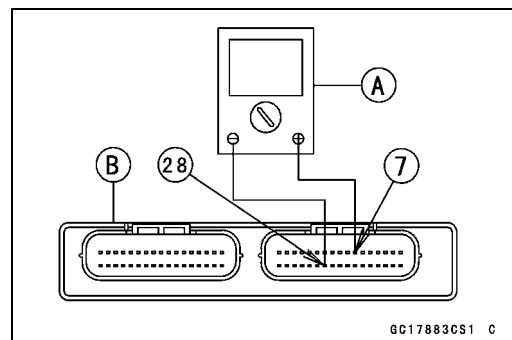

## Main Throttle Sensor (Service Code 11)

- ★ If the output voltage is within the standard range, check the ECU for a good ground, and power supply (see ECU Power Supply Inspection). If the ground and power supply are good, replace the ECU.
- ★ If the output voltage is far out of the standard range (e.g. when the wiring is open, the reading is 0 V), check the output voltage again at the sensor connector.

- Disconnect the main throttle sensor connector and connect the harness adapter [A] between the harness connector and main throttle sensor connector.
- Connect a digital meter [B] to the harness adapter leads.

**Special Tool - Throttle Sensor Setting Adapter: 57001-1538**

### Main Throttle Sensor Output Voltage

#### Connections to Sensor

Meter (+) → Y/W lead

Meter (-) → BR/BK lead

- Measure the sensor output voltage with the engine stopped, and with the connector joined.
- Turn the ignition switch ON.
- Measure the output voltage when the throttle is fully opened or completely closed.

#### Output Voltage at Sensor

**Standard: DC 1.025 ~ 1.055 V (at idle throttle opening)**

**Approximately DC 4.22 ~ 4.42 V (full throttle opening)**

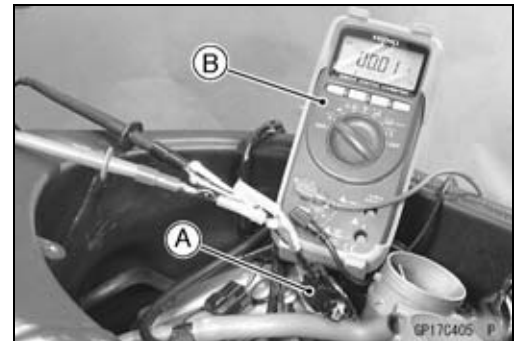

### CAUTION

**Do not remove or adjust the main throttle sensor. It has been adjusted and set with precision at the factory.**

- After throttle sensor voltage inspection, remove the harness adapter.
- ★ If the reading is out of the standard range, inspect the throttle sensor resistance.
- ★ If the output voltage is normal, check the wiring for continuity (see next diagram).

### Main Throttle Sensor Resistance Inspection

- Turn the ignition switch OFF.
- Disconnect the main throttle sensor connector.
- Connect a digital meter [A] to the main throttle sensor connector [B].
- Measure the main throttle sensor resistance.

#### Main Throttle Sensor Resistance

**Connections: BL lead [C] ↔ BR/BK lead [D]**

**Standard: Approximately 5 kΩ**

- ★ If the reading is out of the range, replace the throttle body assy (see Throttle Body Assy Removal/Installation).
- ★ If the reading is within the range, but the problem still exists, replace the ECU (see ECU Removal/Installation).

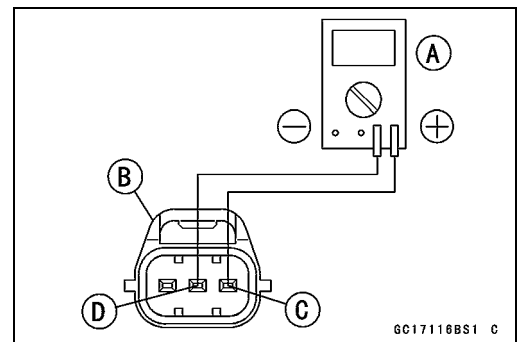

GC17116BS1 C

## 3-46 FUEL SYSTEM (DFI)

### Main Throttle Sensor (Service Code 11)

#### Main Throttle Sensor Circuit

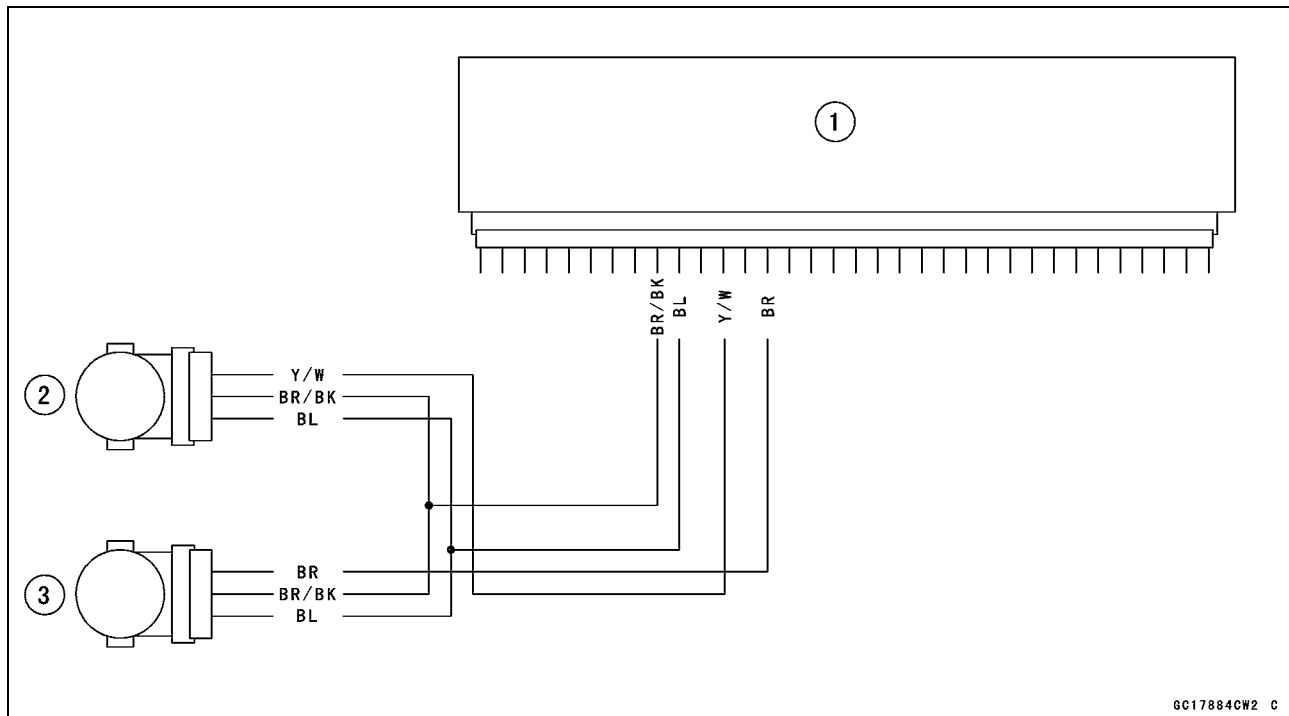

1. ECU
2. Main Throttle Sensor
3. Subthrottle Sensor



**Inlet Air Pressure Sensor (Service Code 12)**

**CAUTION**

Never drop the sensor, especially on a hard surface. Such a shock to the part can damage it.

**Inlet Air Pressure Sensor Removal**

- Turn the ignition switch OFF.
- Set up the fuel tank (see Air Cleaner Housing Removal).
- Remove:
  - Inlet Air Pressure Sensor Connector [A]
  - Inlet Air Pressure Sensor [B]
  - Vacuum Hose [C]

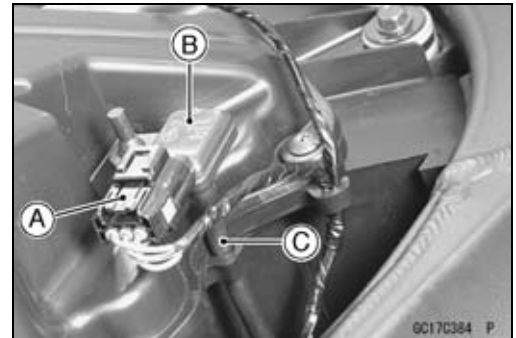

**Inlet Air Pressure Sensor Installation**

- Install:
  - Vacuum Hose [A]
- Put the rubber damper [B] of the inlet air pressure sensor [C] in the slot [D] of air cleaner housing.
- Connect the connector.

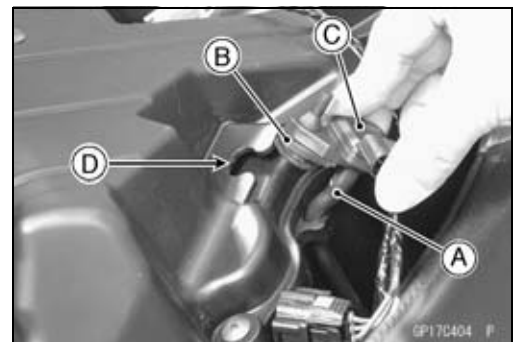

**Inlet Air Pressure Sensor Input Voltage Inspection**

**NOTE**

- Be sure the battery is fully charged.
- The inspection is the same as "Input Voltage Inspection" of the throttle sensor and the atmospheric pressure sensor.

- Turn the ignition switch OFF.
- Remove the ECU (see ECU Removal). Do not disconnect the ECU connectors.
- Connect a digital voltmeter [A] to the connector [B], with the needle adapter set.

**Special Tool - Needle Adapter Set: 57001-1457**

**Inlet Air Pressure Sensor Input Voltage**

**Connections to ECU**

- Meter (+) → BL lead (terminal 10)
- Meter (-) → BR/BK lead (terminal 28)

- Measure the input voltage with the engine stopped, and with the connectors joined.
- Turn the ignition switch ON.

**Input Voltage at ECU**

**Standard: DC 4.75 ~ 5.25 V**

- ★ If the reading is less than the standard range, check the ECU for its ground, and power supply (see ECU Power Supply Inspection). If the ground and power supply are good, replace the ECU (see ECU Removal/Installation).

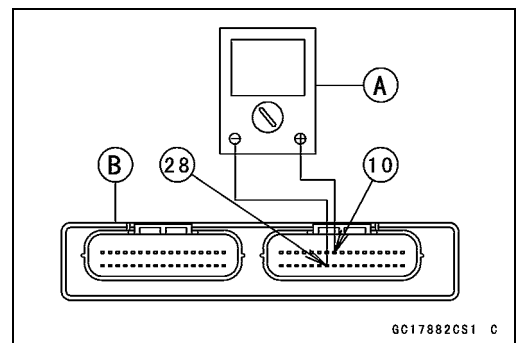

## 3-48 FUEL SYSTEM (DFI)

### Inlet Air Pressure Sensor (Service Code 12)

- ★ If the reading is within the standard range, and check the input voltage again at the sensor connector.
- Disconnect the inlet air pressure sensor connector and connect the harness adapter [A] between the sub harness connector and inlet air pressure sensor connector.
- Connect a digital meter [B] to the harness adapter leads.

**Special Tool - Sensor Harness Adapter: 57001-1561**

#### Inlet Air Pressure Sensor Input Voltage

##### Connections to Sensor

Meter (+) → BL lead [C]

Meter (-) → BR/BK lead [D]

- Measure the input voltage with the engine stopped.
- Turn the ignition switch ON.

##### Input Voltage at Sensor Connector

**Standard: DC 4.75 ~ 5.25 V**

- ★ If the reading is out of the standard range, check the wiring (see wiring diagram).
- ★ If the reading is good, the input voltage is normal. Check the output voltage.
- Turn the ignition switch OFF.

#### Inlet Air Pressure Sensor Output Voltage Inspection

- Measure the output voltage at the ECU in the same way as input voltage inspection.

##### Inlet Air Pressure Sensor Output Voltage

##### Connections to ECU

Meter (+) → Y/BL lead (terminal 8)

Meter (-) → BR/BK lead (terminal 28)

##### Output Voltage at ECU

**Usable Range: DC 3.80 ~ 4.20 V at the standard atmospheric pressure (101.32 kPa, 76 cmHg abs.)**

#### NOTE

- The output voltage changes according to the local atmospheric pressure.
  - The inlet air pressure sensor output voltage is based on a nearly perfect vacuum in the small chamber of the sensor. So, the sensor indicates absolute vacuum pressure.
- ★ If the output voltage is within the usable range, check the ECU for its ground, and power supply (see ECU Power Supply Inspection). If the ground and power supply are good, replace the ECU (see ECU Removal/Installation).

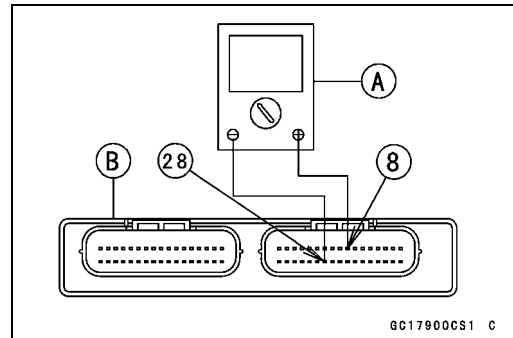
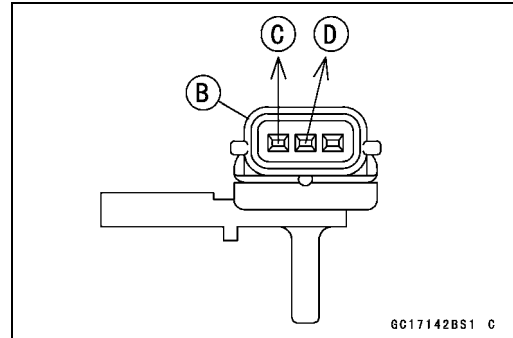
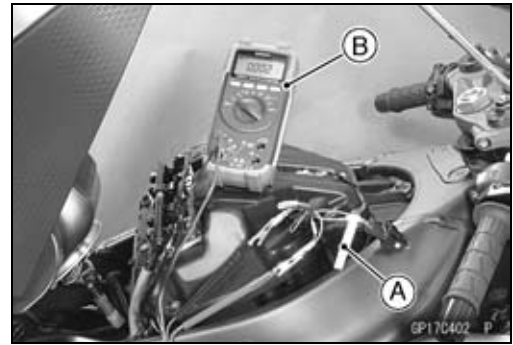

**Inlet Air Pressure Sensor (Service Code 12)**

★If the output voltage is far out of the usable range, check the output voltage again at the sensor connector [A] (when the lead is open, the output voltage is about 1.8 V.).

- Connect a digital meter to the harness adapter leads.  
Inlet Air Pressure Sensor [B]

**Special Tool - Sensor Harness Adapter: 57001-1561**

**Inlet Air Pressure Sensor Output Voltage**

**Connections to Sensor**

Meter (+) → Y/BL lead [C]

Meter (-) → BR/BK lead [D]

**Output Voltage at Sensor Connector**

**Usable Range: DC 3.80 ~ 4.20 V at the standard atmospheric pressure (101.32 kPa or 76 cmHg abs.)**

★If the output voltage is normal, check the wiring for continuity.

★If the output voltage is out of the usable range, replace the sensor.

- Turn the ignition switch OFF.
- Remove the sensor harness adapter.

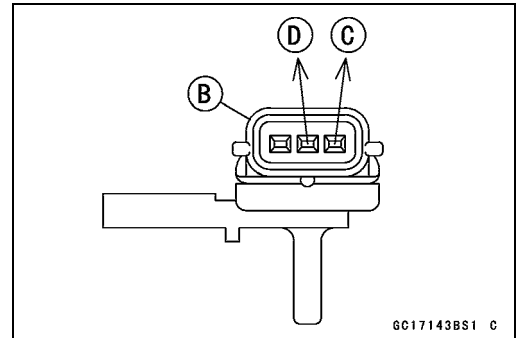
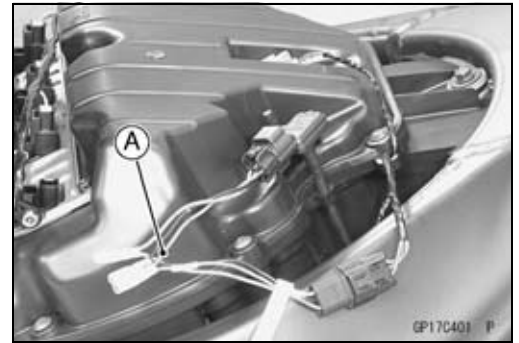

**Inlet Air Pressure Sensor Circuit**

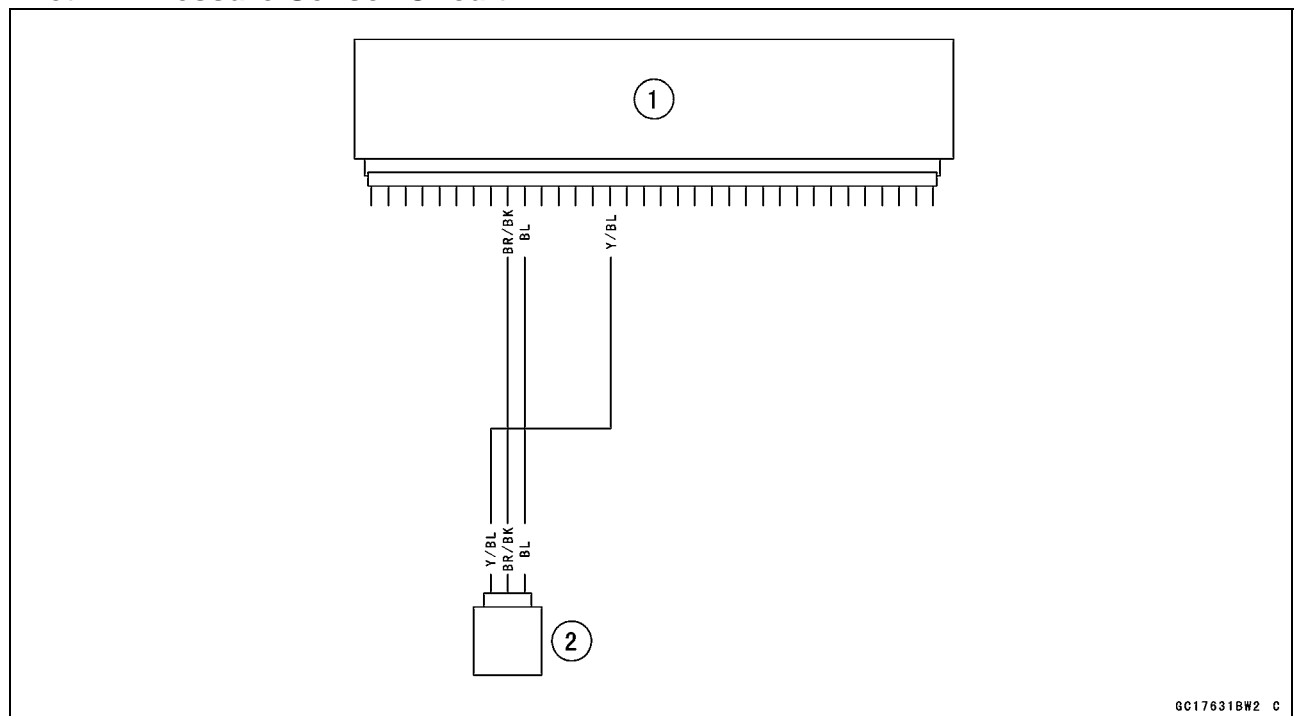

1. ECU
2. Inlet Air Pressure Sensor

★If you need to check the inlet air pressure sensor for vacuum other than 76 cmHg (abs.), check the output voltage as follows:



Inlet Air Pressure Sensor (Service Code 12)

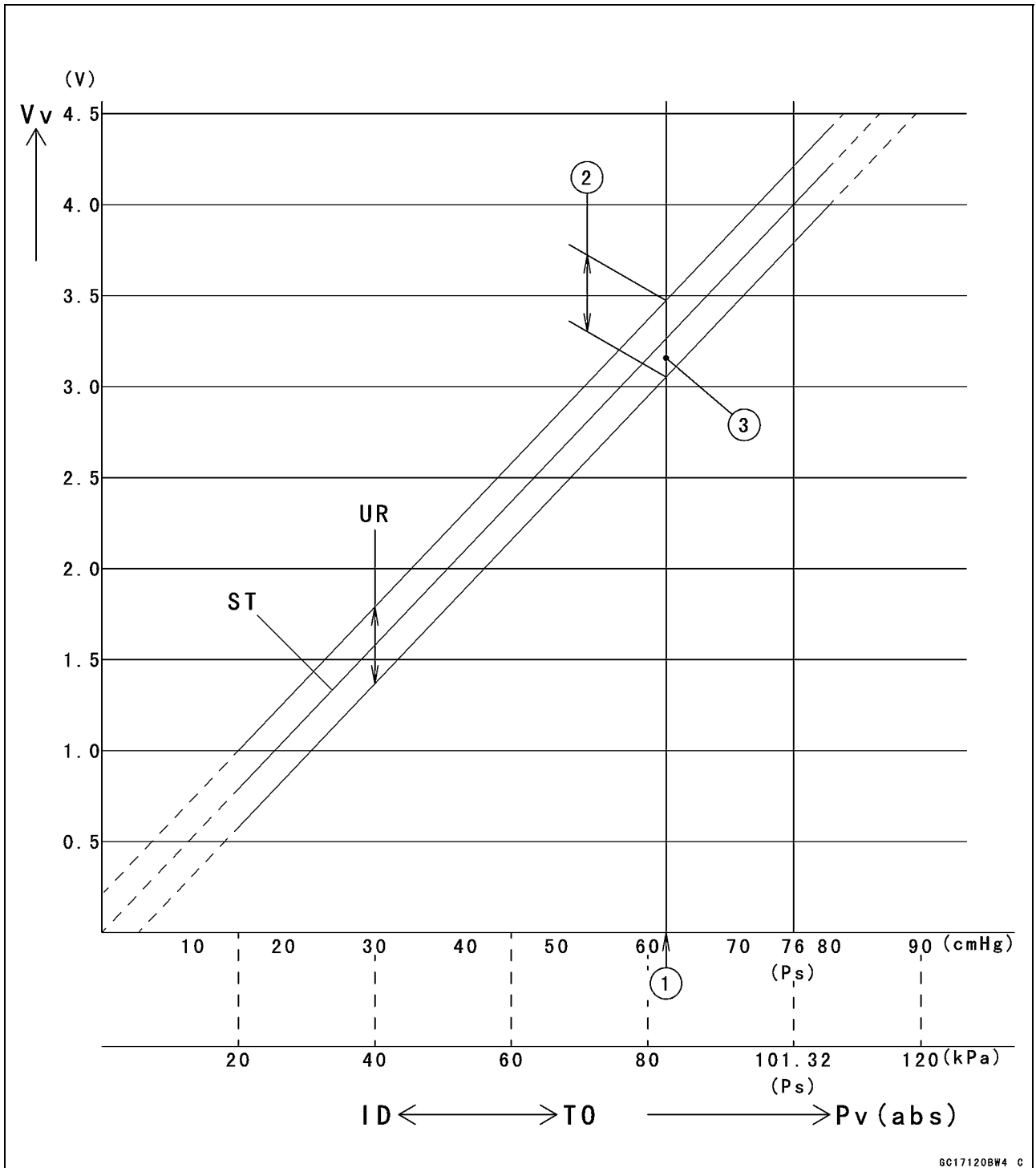

ID: Idling

Ps: Standard Atmospheric Pressure (Absolute)

Pv: Throttle Vacuum Pressure (Absolute)

ST: Standard of Sensor Output Voltage (V)

TO: Throttle Full Open

UR: Usable Range of Sensor Output Voltage (V)

Vv: Inlet Air Pressure Sensor Output Voltage (V) (Digital Meter Reading)

## 3-52 FUEL SYSTEM (DFI)

### Inlet Air Temperature Sensor (Service Code 13)

#### Inlet Air Temperature Sensor Removal/Installation

##### CAUTION

Never drop the sensor, especially on a hard surface. Such a shock to the sensor can damage it.

- Set up the fuel tank (see Air Cleaner Housing Removal).
- Disconnect the connector [A] from the inlet air temperature sensor.
- Pull out the inlet air temperature sensor [B].
- Install the inlet air temperature sensor [A] in the grommet [B].

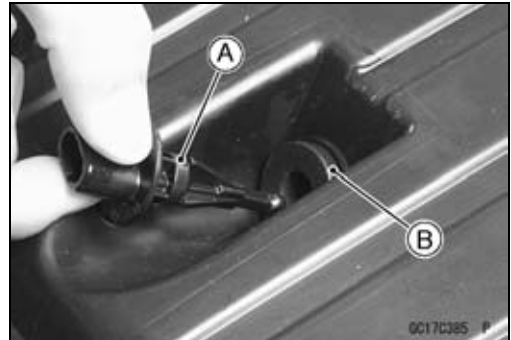
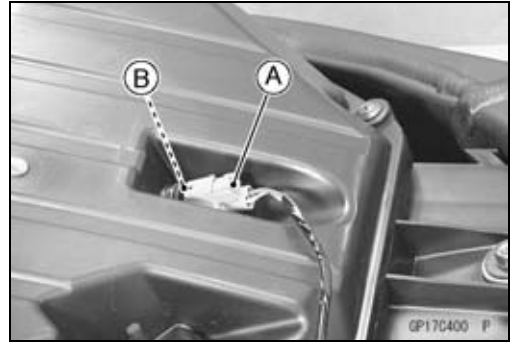

#### Inlet Air Temperature Sensor Output Voltage Inspection

##### NOTE

○ Be sure the battery is fully charged.

- Remove the ECU (see ECU Removal). Do not disconnect the ECU connectors.
- Connect a digital voltmeter [A] to the ECU connector, using needle adapter set [B].

**Special Tool - Needle Adapter Set: 57001-1457**

#### Inlet Air Temperature Sensor Output Voltage Connections to ECU Connector

Meter (+) → Y lead (terminal 26)

Meter (-) → BR/BK lead (terminal 28)

- Measure the sensor output voltage with the engine stopped and the connector joined.
- Turn the ignition switch ON.

#### Output Voltage at ECU

Standard: About 2.25 ~ 2.50 V at inlet air temperature 20°C (68°F)

##### NOTE

○ The output voltage changes according to the inlet air temperature.

- Turn the ignition switch OFF.

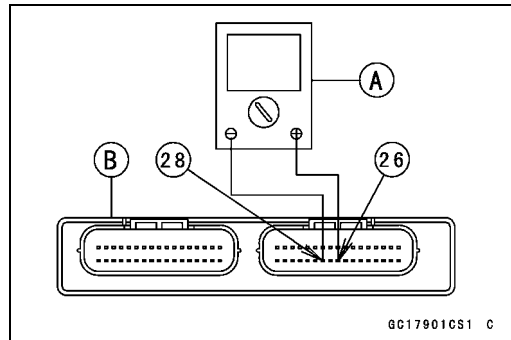

## Inlet Air Temperature Sensor (Service Code 13)

- ★ If the output voltage is out of the specified, check the ECU for its ground, and power supply (see ECU Power Supply Inspection). If the ground and power supply are good, replace the ECU (see ECU Removal/Installation).
- ★ If the output voltage is far out of the specified (e.g. when the wiring is open, the voltage is about DC 5.0 V.), check the wiring.
- Remove the needle adapter set, and apply silicone sealant to the seals of the connector for waterproofing.  
**Sealant - Kawasaki Bond (Silicone Sealant): 56019-120**
- ★ If the wiring is good, check the sensor resistance.

### Inlet Air Temperature Sensor Resistance Inspection

- Remove the inlet air temperature sensor (see Inlet Air Temperature Sensor Removal).
- Suspend the sensor [A] in a container of machine oil so that the heat-sensitive portion is submerged.
- Suspend a thermometer [B] with the heat-sensitive portion [C] located in almost the same depth with the sensor.

#### NOTE

- The sensor and thermometer must not touch the container side or bottom.
- Place the container over a source of heat and gradually raise the temperature of the oil while stirring the oil gently for even temperature.
- Using a digital meter, measure the internal resistance of the sensor across the terminals at the temperatures shown in the table.

#### Inlet Air Temperature Sensor Resistance

Standard: 2.09 ~ 2.81 kΩ at 20°C (68°F)

About 0.322 kΩ at 80°C (176°F) (reference valve)

- ★ If the measurement is out of the range, replace the sensor.
- ★ If the measurement is within the specified, replace the ECU (see ECU Removal/Installation).

### Inlet Air Temperature Sensor Circuit

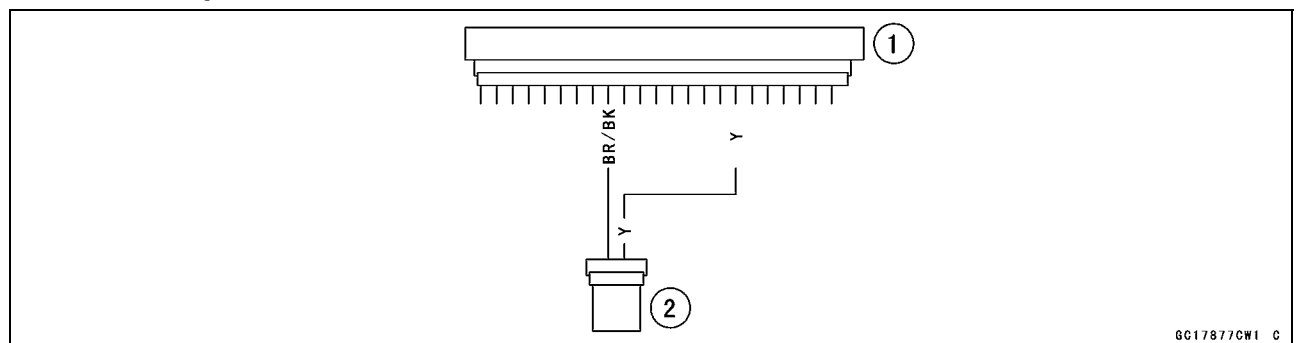

1. ECU
2. Inlet Air Temperature Sensor

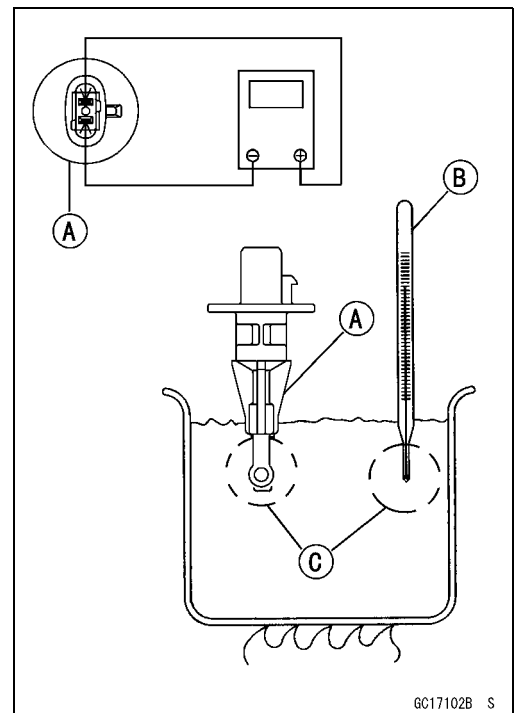

GC17102B S

GC17877CW1 C

## 3-54 FUEL SYSTEM (DFI)

### Water Temperature Sensor (Service Code 14)

#### Water Temperature Sensor Removal/Installation

##### CAUTION

**Never drop the sensor, especially on a hard surface. Such a shock to the sensor can damage it.**

- Drain the coolant (see Coolant Change in the Periodic Maintenance chapter).
- Remove the throttle body assy (see Throttle Body Assy Removal).
- Remove:
  - Connector
  - Heat Insulation Rubber Plate
  - Water Temperature Sensor [A]
- Replace the gasket with new one.
- Apply silicone sealant to the threads of the water temperature sensor and tighten it.

**Sealant - Kawasaki Bond (Silicone Sealant): 56019-120**

**Torque - Water Temperature Sensor: 25 N·m (2.5 kgf·m, 18 ft·lb)**

- Fill the engine with coolant and bleed the air from the cooling system (see Coolant Filling in the Cooling System chapter).

#### Water Temperature Sensor Output Voltage Inspection

##### NOTE

○ Be sure the battery is fully charged.

- Remove the ECU (see ECU Removal). Do not disconnect the connectors.
- Connect a digital voltmeter [A] to the ECU connectors [B], with the needle adapter set.

**Special Tool - Needle Adapter Set: 57001-1457**

#### Water Temperature Sensor Output Voltage

##### Connections to ECU

Meter (+) → O lead (terminal 9)

Meter (-) → BR/BK lead (terminal 28)

- Measure the sensor output voltage with the engine stopped and the connector joined.
- Turn the ignition switch ON.

#### Output Voltage at ECU

**Standard: About 2.80 ~ 2.97 V at 20°C (68°F)**

##### NOTE

○ The output voltage changes according to the coolant temperature in the engine.

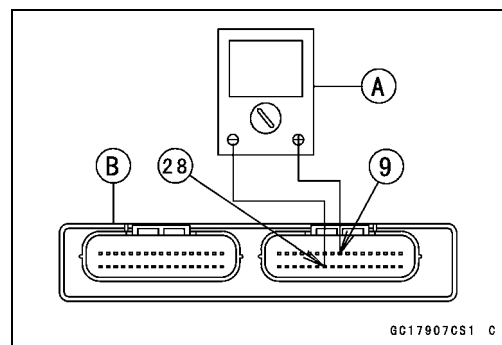



## Water Temperature Sensor (Service Code 14)

- Turn the ignition switch OFF.
  - ★ If the output voltage is out of the specified, check the ECU for its ground, and power supply (see ECU Power Supply Inspection). If the ground and power supply are good, replace the ECU (see ECU Removal/Installation).
  - ★ If the output voltage is far out of the specified (e.g. when the wiring is open, the voltage is about 5 V.), check the wiring.
  - ★ If the wiring is good, check the water temperature sensor resistance.
  - Remove the needle adapter set, and apply silicone sealant to the seals of the connector for waterproofing.
- Sealant - Kawasaki Bond (Silicone Sealant): 56019-120**

### Water Temperature Sensor Circuit

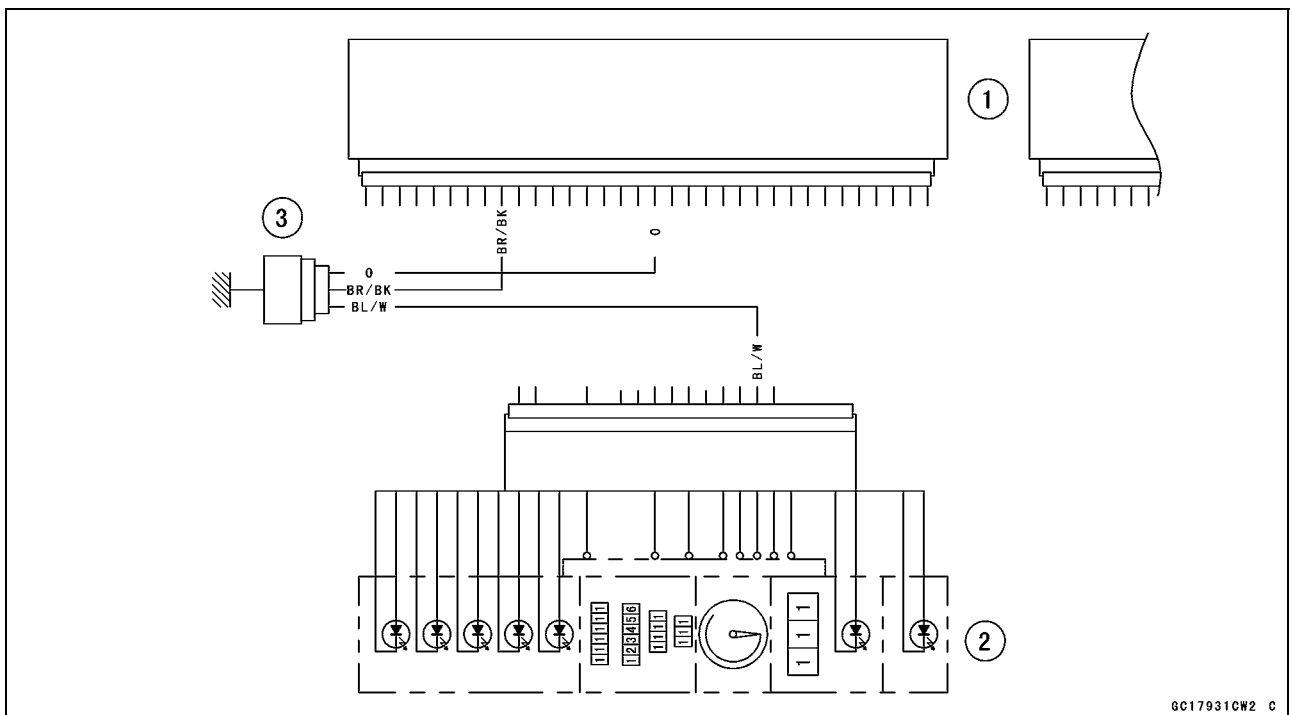

1. ECU
2. Meter Unit
3. Water Temperature Sensor

### **Water Temperature Sensor Resistance Inspection**

- Remove the water temperature sensor (see Water Temperature Sensor Removal/Installation).
- Refer to the Electrical System chapter for water temperature sensor inspection.

## 3-56 FUEL SYSTEM (DFI)

### Atmospheric Pressure Sensor (Service Code 15)

#### CAUTION

Never drop the sensor, especially on a hard surface. Such a shock to the sensor can damage it.

#### Atmospheric Pressure Sensor Removal

- Turn the ignition switch OFF.
- Remove:
  - Seat (see Seat Removal in the Frame chapter)
  - Atmospheric Pressure Sensor Connector [A]
  - Atmospheric Pressure Sensor [B] with Damper

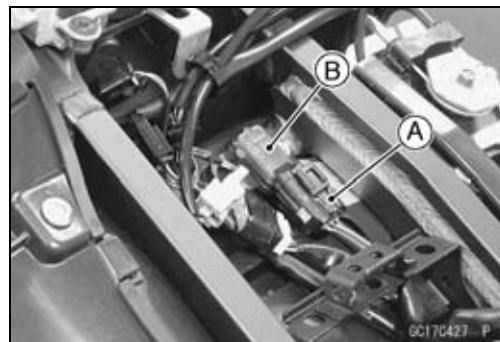

#### Atmospheric Pressure Sensor Installation

- Put the damper [A] of the atmospheric pressure sensor in the hole [B] of the stay plate.

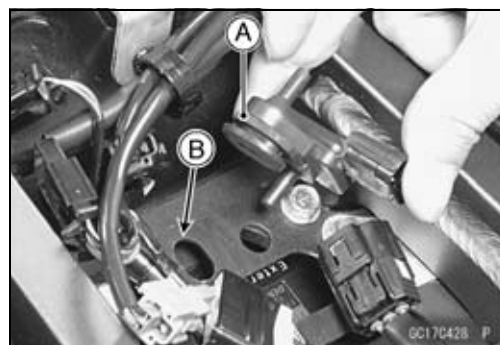

#### Atmospheric Pressure Sensor Input Voltage Inspection

##### NOTE

- Be sure the battery is fully charged.
- The inspection is the same as "Input Voltage Inspection" of the throttle sensor and the inlet air pressure sensor.

- Turn the ignition switch OFF.
- Remove the ECU (see ECU Removal). Do not disconnect the ECU connectors.
- Connect a digital voltmeter [A] to the connector [B], with the needle adapter set.

**Special Tool - Needle Adapter Set: 57001-1457**

#### Atmospheric Pressure Sensor Input Voltage Connections to ECU

Meter (+) → BL lead (terminal 10)

Meter (-) → BR/BK lead (terminal 28)

- Measure the input voltage with the engine stopped, and with the connectors joined.
- Turn the ignition switch ON.

#### Input Voltage at ECU

**Standard: DC 4.75 ~ 5.25 V**

- ★ If the reading of input voltage is less than the standard range, check the ECU for its ground, and power supply (see ECU Power Supply Inspection). If the ground and power supply are good, replace the ECU (see ECU Removal/Installation).

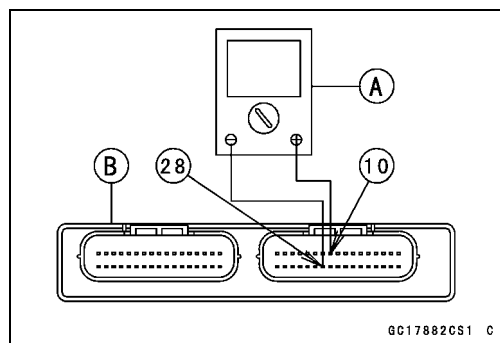

**Atmospheric Pressure Sensor (Service Code 15)**

- ★ If the reading is within the standard range, check the input voltage again at the sensor connector.
- Remove the seat cover (see Seat Cover Removal in the Frame chapter).
- Disconnect the atmospheric pressure sensor connector and connect the harness adapter [A] between the main harness connector and atmospheric pressure sensor connector.
- Connect a digital meter to the harness adapter leads.

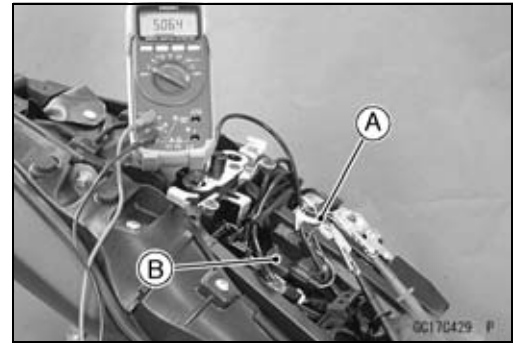

**Special Tool - Sensor Harness Adapter: 57001-1561**

**Atmospheric Pressure Sensor Input Voltage**

**Connections to Sensor**

Meter (+) → BL lead [C]

Meter (-) → BR/BK lead [D]

- Measure the input voltage with the engine stopped, and with the connector joined.
- Turn the ignition switch ON.

**Input Voltage at Sensor Connector**

**Standard: DC 4.75 ~ 5.25 V**

- ★ If the reading is out of the standard range, check the wiring (see wiring diagram).
- ★ If the reading is good, the input voltage is normal. Check the output voltage.
- Turn the ignition switch OFF.

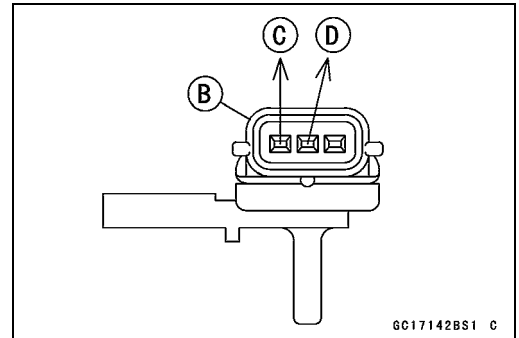

**Atmospheric Pressure Sensor Output Voltage Inspection**

- Measure the output voltage at the ECU in the same way as input voltage inspection.

Digital Meter [A]

ECU Connector [B]

**Atmospheric Pressure Sensor Output Voltage**

**Connections to ECU**

Meter (+) → G/W lead (terminal 25)

Meter (-) → BR/BK lead (terminal 28)

**Output Voltage**

**Usable Range: DC 3.80 ~ 4.20 V at the standard atmospheric pressure (101.32 kPa, 76 cmHg abs.)**

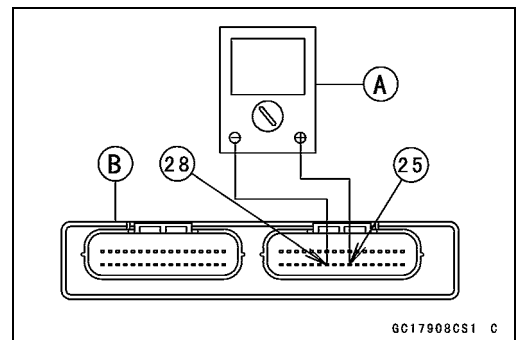

**NOTE**

- The output voltage changes according to the local atmospheric pressure.
  - The atmospheric sensor output voltage is based on a nearly perfect vacuum in the small chamber of the sensor. So, the sensor indicates absolute atmospheric pressure.
- ★ If the output voltage is within the usable range, check the ECU for its ground, and power supply (see ECU Power Supply Inspection). If the ground and power supply are good, replace the ECU (see ECU Removal/Installation).

## 3-58 FUEL SYSTEM (DFI)

### Atmospheric Pressure Sensor (Service Code 15)

★ If the output voltage is far out of the usable range, check the output voltage at the sensor connector [A] (when the wiring is open, the output voltage is about 1.8 V.).

- Connect a digital meter to the harness adapter leads.  
Atmospheric Pressure Sensor [B]

**Special Tool - Sensor Harness Adapter: 57001-1561**

#### Atmospheric Pressure Sensor Output Voltage

##### Connections to Sensor

Meter (+) → G/W lead [C]

Meter (-) → BR/BK lead [D]

##### Output Voltage at Sensor

**Usable Range: DC 3.80 ~ 4.20 V at the standard atmospheric pressure (101.32 kPa, 76 cmHg abs.)**

★ If the output voltage is normal, check the wiring for continuity.

★ If the output voltage is out of the usable range, replace the sensor.

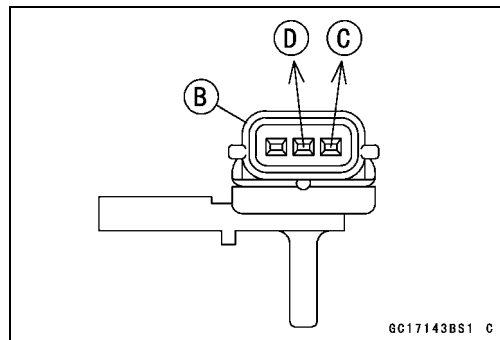
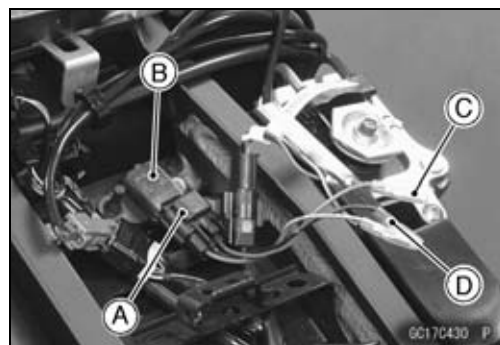

### Atmospheric Pressure Sensor Circuit

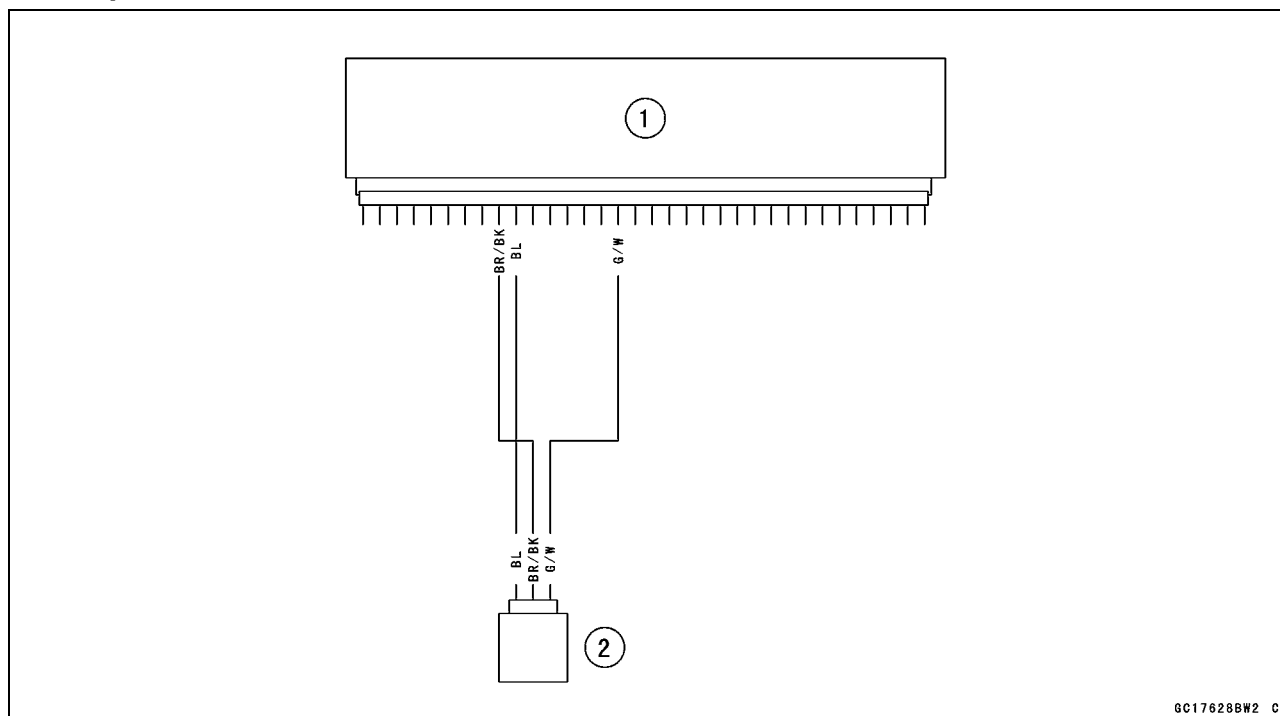

1. ECU

2. Atmospheric Pressure Sensor

★ If you need to check the atmospheric pressure sensor for various altitudes other than sea level, check the output voltage as follows:

- Determine the local altitude (Elevation).

**Atmospheric Pressure Sensor (Service Code 15)**

★If you know the local atmospheric pressure using a barometer, substitute the atmospheric pressure for throttle vacuum pressure in the inlet air pressure sensor chart (see Inlet Air Pressure Sensor section). And get the usable range of the atmospheric pressure sensor output voltage and check if output voltage is within the standard or not in the same way as Output Voltage Inspection of the inlet air pressure sensor.

★If you know the local altitude, use the following chart.

**Atmospheric Pressure/Altitude Relationship**

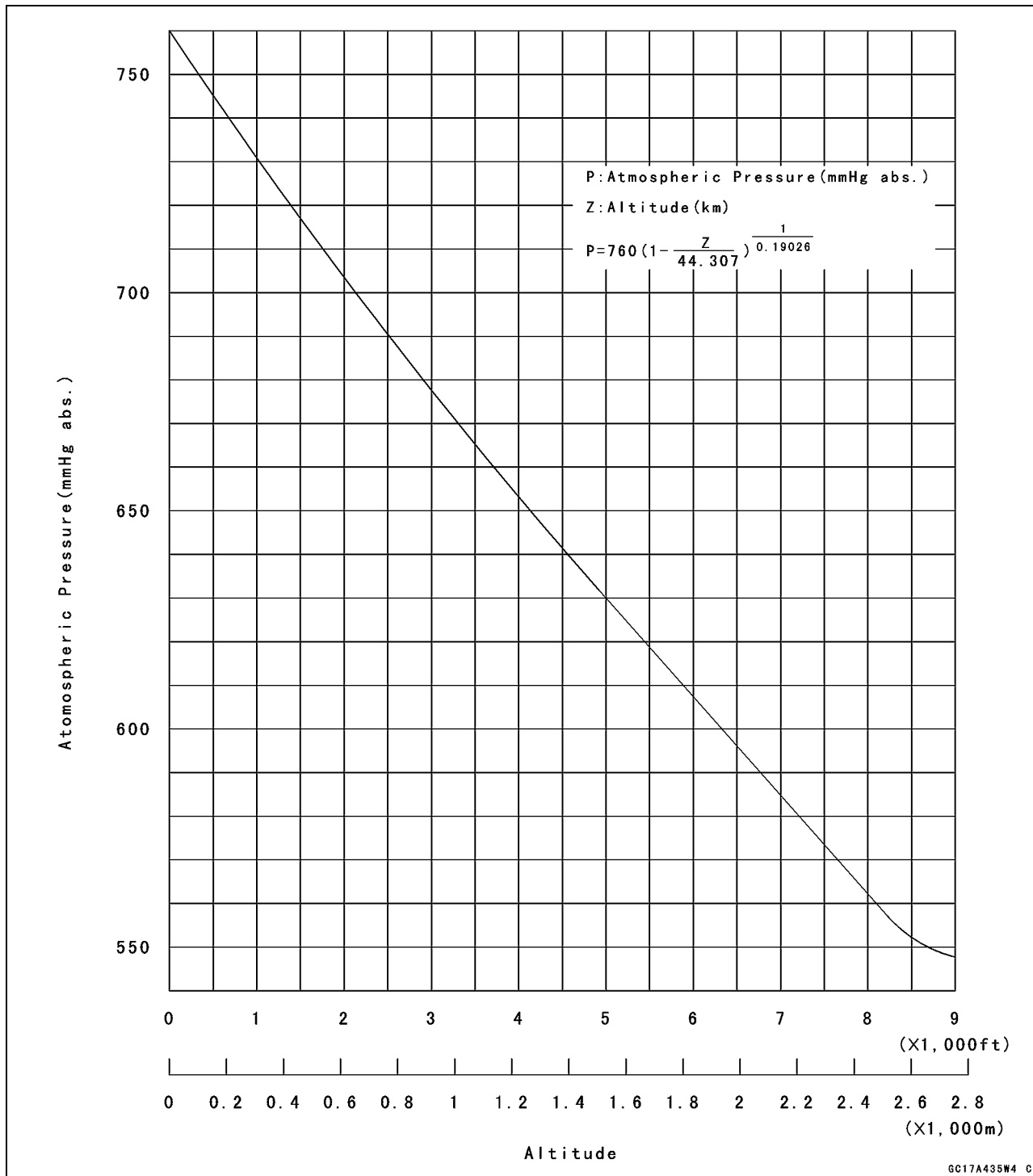

## 3-60 FUEL SYSTEM (DFI)

### Crankshaft Sensor (Service Code 21)

#### **Crankshaft Sensor Removal/Installation**

- Refer to the Crankshaft Sensor Removal/Installation in the Electrical System chapter (see Crankshaft Sensor Removal/Installation in the Electrical System chapter).

#### **Crankshaft Sensor Inspection**

- The crankshaft has no power source, and when the engine stops, the crankshaft generates no signals.
- Crank the engine and measure the peak voltage of the crankshaft sensor (see Crankshaft Sensor Peak Voltage Inspection in the Electrical System chapter) in order to check the sensor.
- Check the wiring for continuity.

#### **Crankshaft Sensor Circuit**

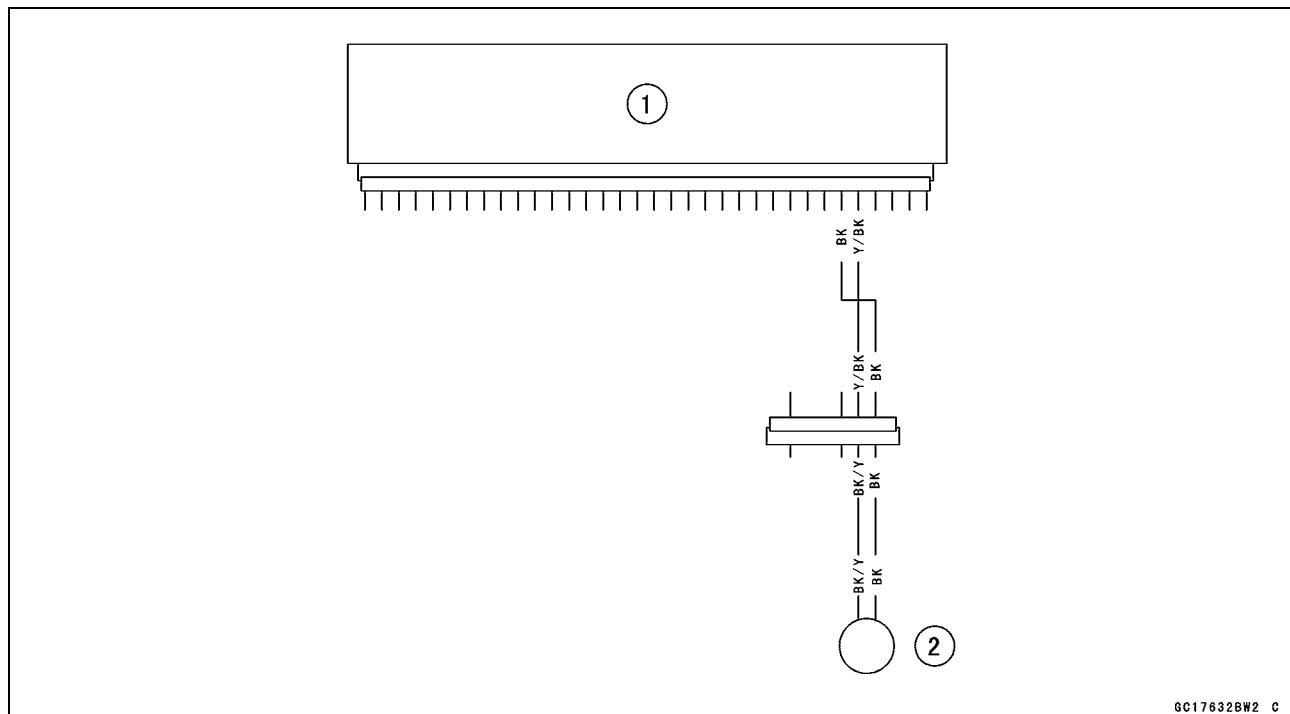

1. ECU
2. Crankshaft Sensor

**Camshaft Position Sensor (Service Code 23)**

**Camshaft Position Sensor Removal/Installation**

The camshaft position sensor detects the position of the camshaft, and distinguishes the cylinder.

- Refer to the Camshaft Position Sensor Removal/Installation in the Electrical System chapter (see Camshaft Position Sensor Removal/Installation in the Electrical System chapter).

**Camshaft Position Sensor Inspection**

- The camshaft position sensor have no power source, and when the engine stops, the camshaft position sensor generates no signal.
- Crank the engine and measure the peak voltage of the camshaft position sensor (see Camshaft Position Sensor Peak Voltage Inspection in the Electrical System chapter) in order to check the sensor.
- Check the wiring for continuity.

**Camshaft Position Sensor Circuit**

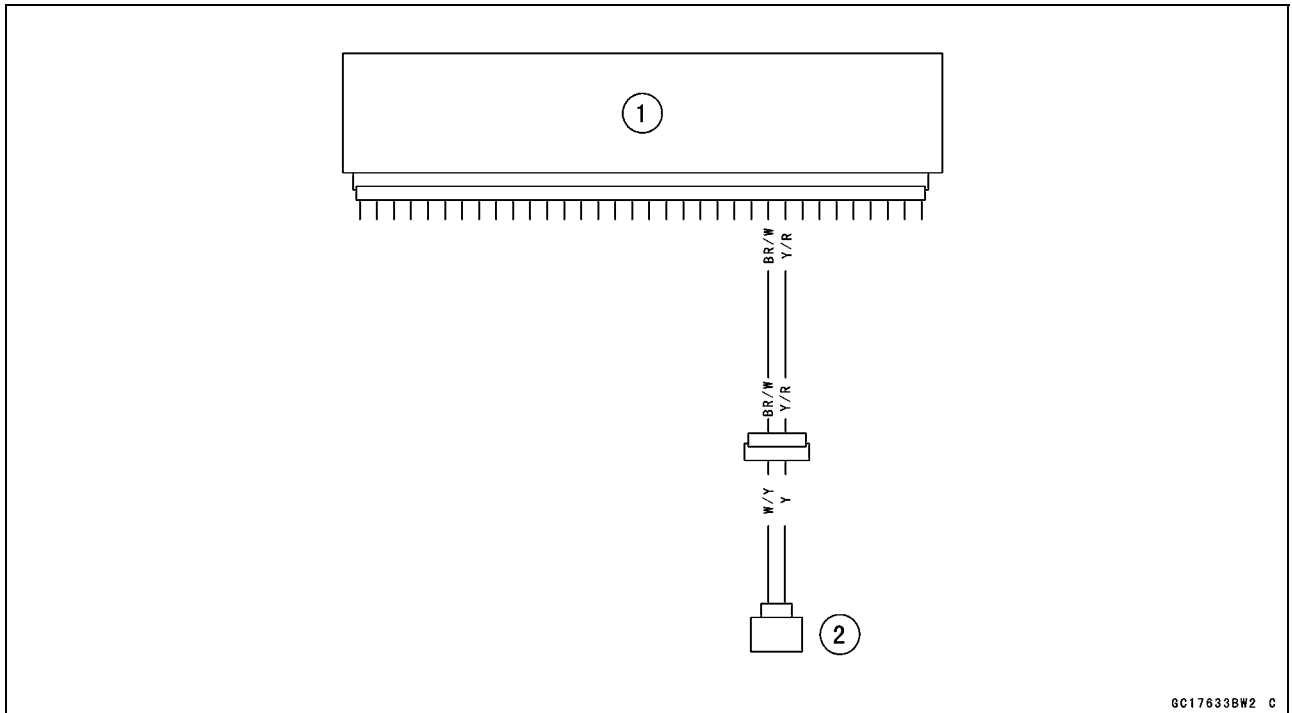

1. ECU
2. Camshaft Position Sensor

## 3-62 FUEL SYSTEM (DFI)

### Speed Sensor (Service Code 24)

#### **Speed Sensor Removal/Installation**

- See the Speed Sensor Removal/Installation in the Electrical System chapter.

#### **Speed Sensor Inspection**

- See the Speed Sensor Inspection in the Electrical System chapter.

#### **Speed Sensor Input Voltage Inspection**

##### **NOTE**

○ Be sure the battery is fully charged.

- Turn the ignition switch OFF.
- Set up the fuel tank (see Air Cleaner Housing Removal).
- Disconnect the speed sensor connector, and connect the setting adapter [A] between the harness connector [B] and speed sensor connector [C].
- Connect a digital meter to the setting adapter leads.

**Special Tool - Throttle Sensor Setting Adapter #1: 57001-1400**

##### **Speed Sensor Input Voltage**

##### **Connector to Sensor**

**Meter (+) → P lead [C]**

**Meter (-) → BK/Y lead [D]**

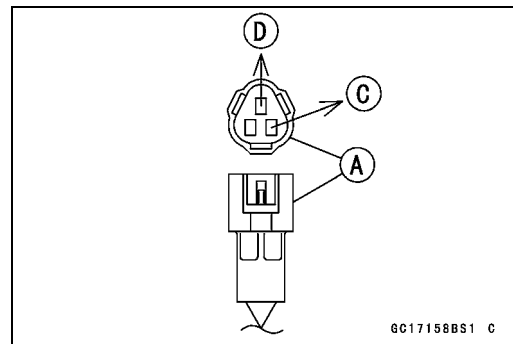
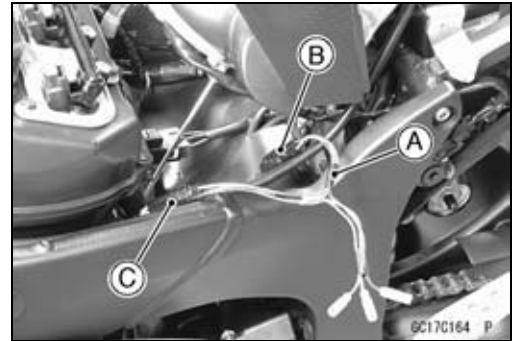

- Measure the sensor input voltage with the engine stopped, and with the connector joined.
- Turn the ignition switch ON.

##### **Input Voltage at Sensor**

**Standard: About DC 9 ~ 11 V**

- ★ If the reading is out of the range, check the wiring (see wiring diagram), and meter unit (see Meter Unit (Electronic Combination) Inspection in the Electrical System chapter).
- ★ If the reading is good, check the output voltage.
- Turn the ignition switch OFF.

#### **Speed Sensor Output Voltage Inspection**

- Before this inspection, inspect the input voltage (see Input Voltage Inspection).

##### **NOTE**

○ Be sure the battery is fully charged.

- Turn the ignition switch OFF.



### Speed Sensor (Service Code 24)

- Disconnect the speed sensor connector, and connect the setting adapter [A] between the harness connector [B] and speed sensor connector [C].
- Connect a digital meter to the setting adapter leads.

**Special Tool - Throttle Sensor Setting Adapter #1: 57001-1400**

**Speed Sensor Output Voltage**

**Connections to Sensor**

**Meter (+) → Y lead [C]**

**Meter (-) → BK/Y lead [D]**

- Measure the sensor output voltage with the engine stopped, and with the connector joined.
- Turn the ignition switch ON.

**Output Voltage at Sensor**

**Standard: About DC 0.05 ~ 0.07 V**

**NOTE**

○ If you can rotate the drive shaft, the output voltage will be raise.

- ★ If the reading is out of the range, check the speed sensor (see Speed Sensor Inspection in the Electrical System chapter) and the wiring to ECU (see wiring diagram).
- ★ If the reading, speed sensor and wiring are good, replace the ECU (see ECU Removal/Installation).

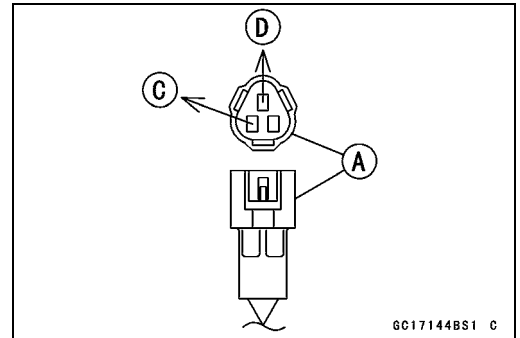
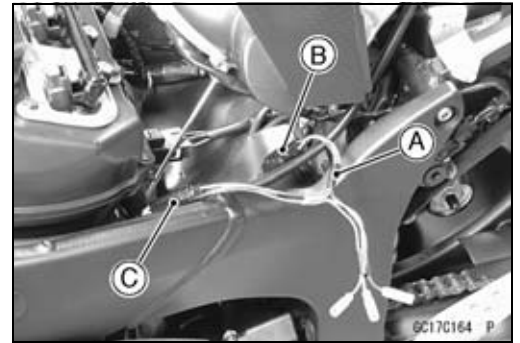

### Speed Sensor Circuit

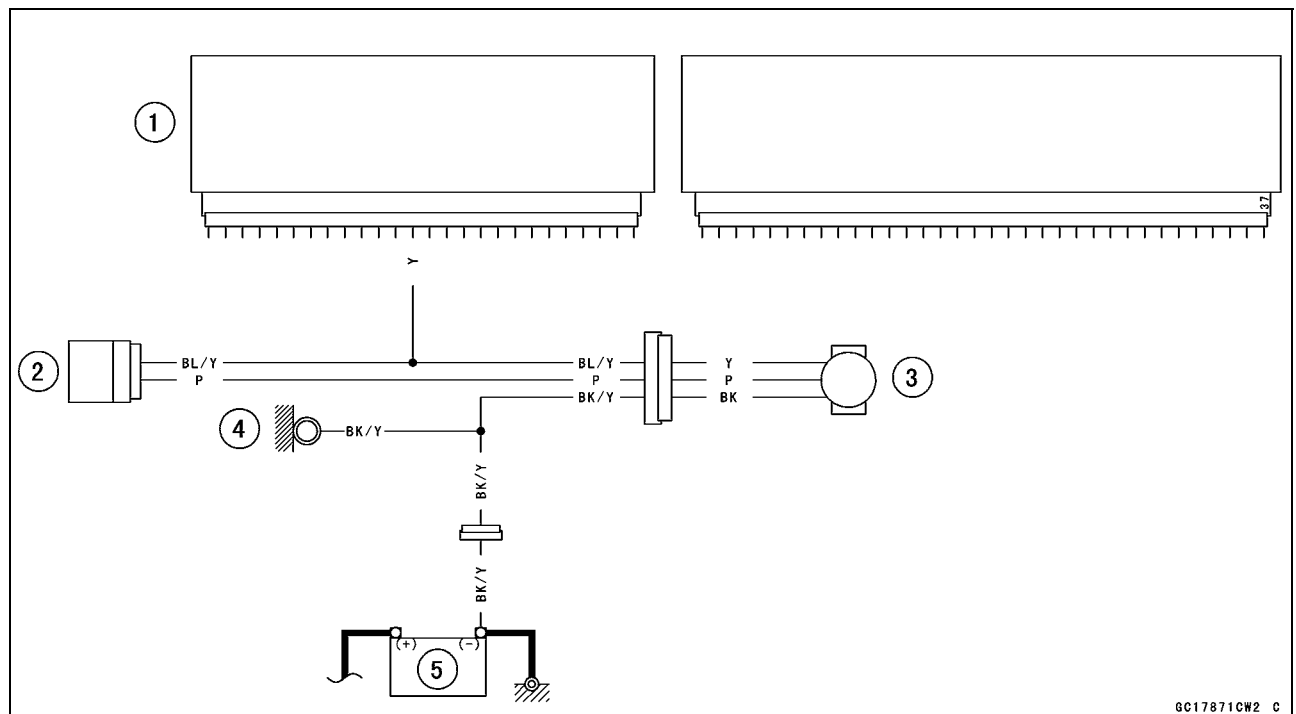

1. ECU
2. Meter Unit
3. Speed Sensor
4. Frame Ground
5. Battery 12 V 8 Ah

## 3-64 FUEL SYSTEM (DFI)

### Gear Position Switch (Service Code 25)

#### **Gear Position Switch Removal/Installation**

- Refer to the Gear Position Switch Removal/Installation in the Electrical System chapter (see Gear Position Switch Removal/Installation in the Electrical System chapter).

#### **Gear Position Switch Inspection**

- Refer to the Gear Position Switch Inspection in the Electrical System chapter (see Gear Position Switch Inspection in the Electrical System chapter).

#### **Gear Position Switch Input Voltage Inspection**

##### **NOTE**

○ Be sure the battery is fully charged.

- Turn the ignition switch OFF.
- Remove the ECU (see ECU Removal).
- Do not disconnect the ECU connectors.
- Connect a digital meter [A] to the connector [B], with the needle adapter set.

**Special Tool - Needle Adapter Set: 57001-1457**

#### **Gear Position Switch Input Voltage at 1 ~ 6 Gear Positions Connections to ECU Connector**

**Meter (+) → W/Y lead (terminal 53)**

**Meter (–) → Engine Ground**

- Measure the switch input voltage with the engine stopped, and with the connector joined.
- Turn the ignition switch ON.

#### **Input Voltage at 1 ~ 6 Gear Positions**

##### **Standard:**

<b>1st</b>	<b>About 3.0 V</b>
<b>2nd</b>	<b>About 2.5 V</b>
<b>3rd</b>	<b>About 2.0 V</b>
<b>4th</b>	<b>About 1.5 V</b>
<b>5th</b>	<b>About 1.1 V</b>
<b>6th</b>	<b>About 0.7 V</b>

- Turn the ignition switch OFF.
- ★ If the reading is out of the range, check the gear position switch (see Gear Position Switch Inspection in the Electrical System chapter).
- ★ If the switch is good, check the ECU for its ground and power supply (see ECU Power Supply Inspection).
- ★ If the ground and power supply are good, replace the ECU (see ECU Removal).

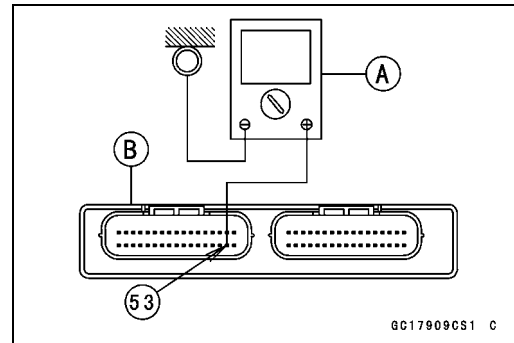

Gear Position Switch (Service Code 25)

Gear Position Switch Circuit

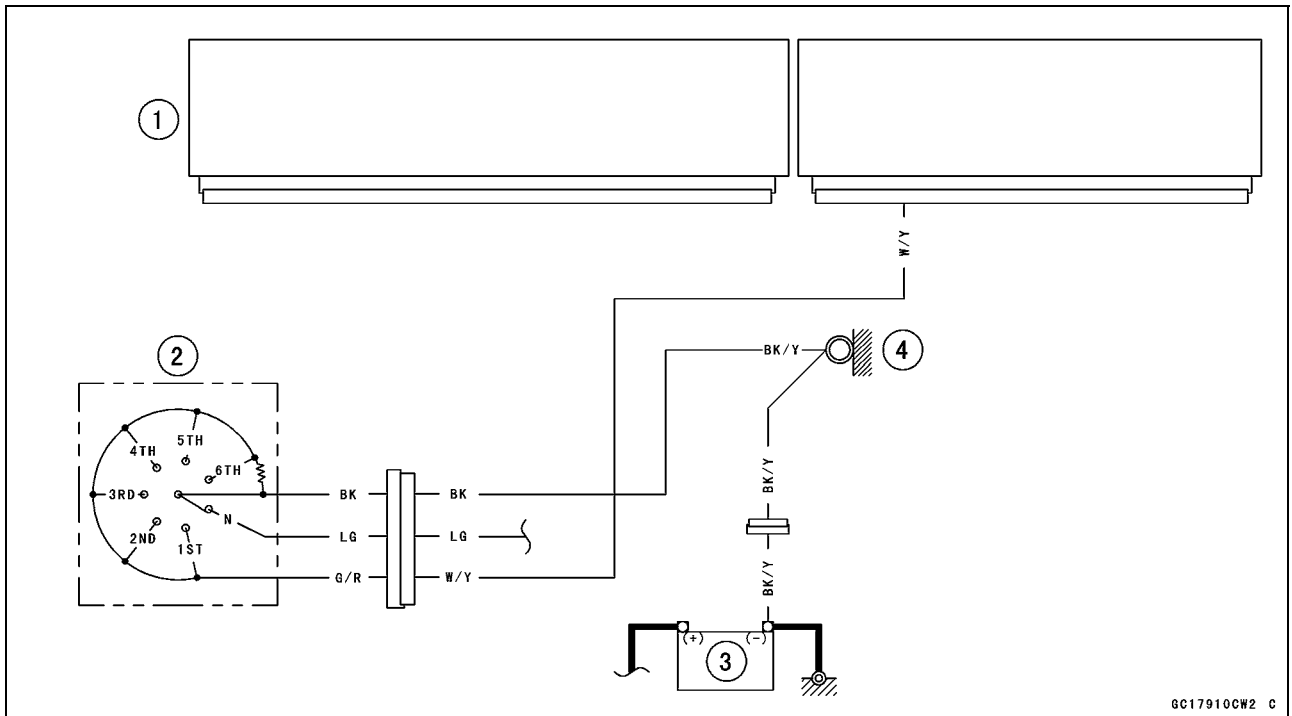

GC17910CW2 C

1. ECU
2. Gear Position Switch
3. Battery 12 V 8 Ah
4. Frame Ground

## 3-66 FUEL SYSTEM (DFI)

### Vehicle-down Sensor (Service Code 31)

This sensor has a weight [A] with two magnets inside, and sends a signal to the ECU. But when the motorcycle banks 60 ~ 70° or more to either side (in fact falls down), the weight turns and shuts off the signal. The ECU senses this change, and stops the fuel pump, the fuel injectors, and the ignition system.

Hall IC [B]

When the motorcycle is down, the ignition switch is left ON. If the starter button is pushed, the electric starter turns but the engine doesn't start. To start the engine again, raise the motorcycle, turn the ignition switch OFF, and then ON. When the ignition switch is turned ON, current flows through the latch-up circuit and the transistor in the circuit is turned ON to unlock the latch-up circuit.

Vehicle-down Sensor [A]

Ground Terminal BR/BK [B]

Output Terminal Y/G [C]

Power Source Terminal BL [D]

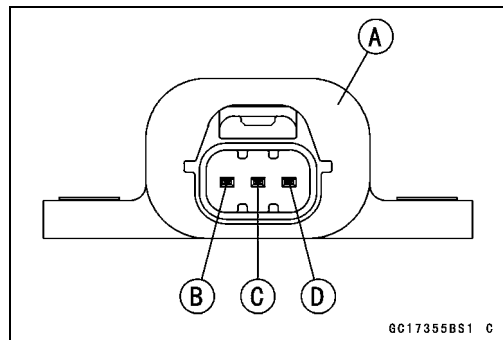
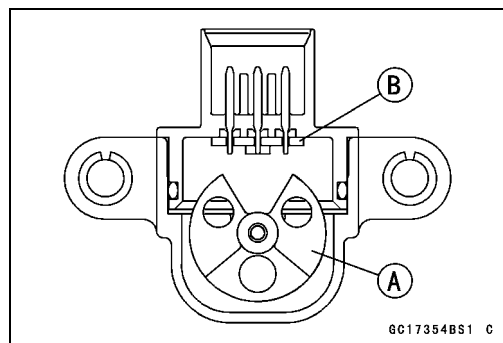

### Vehicle-down Sensor Removal

#### CAUTION

**Never drop the vehicle-down sensor, especially on a hard surface. Such a shock to the sensor can damage it.**

- Remove:
  - Windshield (see Windshield Removal in the Frame chapter)
  - Rubber Cover [A]
  - Connector [B]
  - Bolts [C]
  - Vehicle-down Sensor [D] and collars

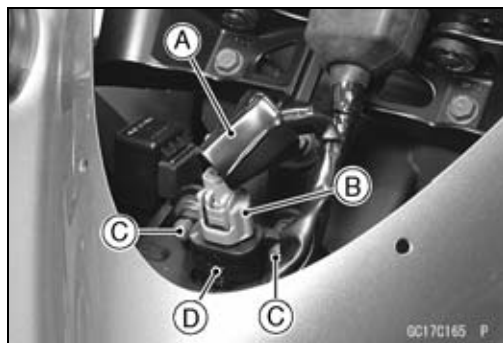

### Vehicle-down Sensor Installation

- The UP mark [A] of the sensor should face upward.
- Tighten:
  - Torque - Vehicle-down Sensor Bolts: 5.9 N·m (0.60 kgf·m, 52 in·lb)

#### ⚠ WARNING

**Incorrect installation of the vehicle-down sensor could cause sudden loss of engine power. The rider could lose balance during certain riding situations, like leaning over in a turn, with the potential for an accident resulting in injury or death. Ensure that the sensor is held in place by the fuel tank bracket.**

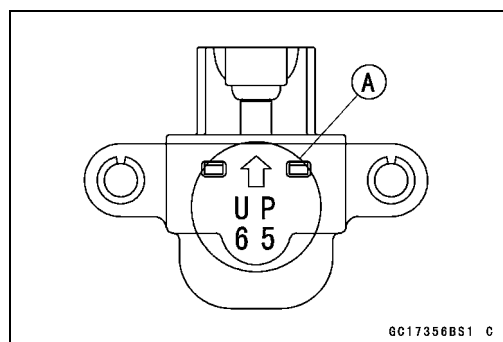

**Vehicle-down Sensor (Service Code 31)**

**Vehicle-down Sensor Inspection**

**NOTE**

○Be sure the battery is fully charged.

- Remove:
    - Windshield (see Windshield Removal in the Frame chapter)
    - Rubber Cover (pry open)
  - Connect a digital volt meter [A] to the connector of the vehicle-down sensor [B], with the needle adapter set [C].
- Special Tool - Needle Adapter Set: 57001-1457**

**Vehicle-down Sensor Power Source Voltage**

**Connections to Sensor**

**Meter (+) → BL lead [D]**

**Meter (-) → BR/BK lead [E]**

- Turn the ignition switch ON, and measure the power source voltage with the connector joined.

**Power Source Voltage at Sensor**

**Standard: DC 4.75 ~ 5.25 V**

- Turn the ignition switch OFF.
- ★ If there is no voltage, check the following:
  - Battery (see Charging Condition Inspection in the Electrical System chapter)
  - ECU Main Relay (see Relay Circuit Inspection in the Electrical System chapter)
  - ECU Fuse 10 A (see Fuse Inspection in the Electrical System chapter)
- ★ If the power source is normal, check the output voltage.

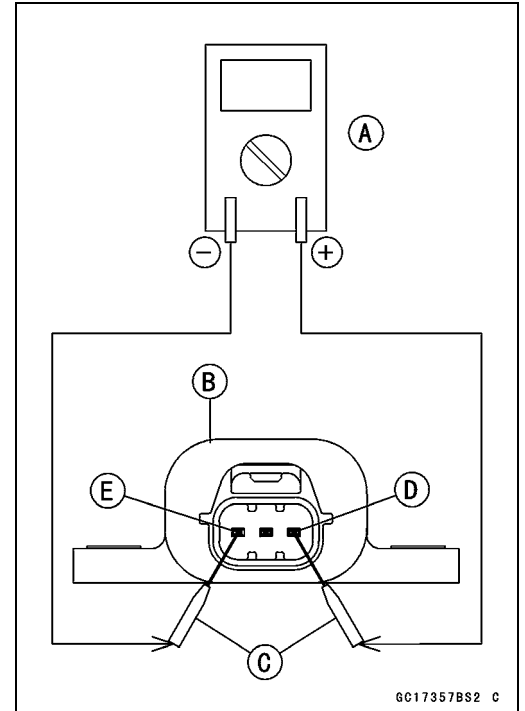

GC17357BS2 C

## 3-68 FUEL SYSTEM (DFI)

### Vehicle-down Sensor (Service Code 31)

- Turn the ignition switch OFF.
- Remove the sensor (see Vehicle-down Sensor Removal).
- Do not disconnect the connector.
- Connect a digital volt meter [A] to the connector, with needle adapter set [B].

**Special Tool - Needle Adapter Set: 57001-1457**

#### Vehicle-down Sensor Output Voltage

##### Connections to Sensor

Meter (+) → Y/G lead [C]

Meter (-) → BR/BK lead [D]

- Hold the sensor vertically.
- Turn the ignition switch ON, and measure the output voltage with the connector joined.
- Tilt the sensor 60 ~ 70° or more [E] right or left, then hold the sensor almost vertical with the arrow mark pointed up, and measure the output voltage.

#### Output Voltage at Sensor

**Standard: with sensor arrow mark pointed up: 3.55 ~ 4.45 V**

**with sensor tilted 60 ~ 70° or more right or left: 0.65 ~ 1.35 V**

#### NOTE

- If you need to test again, turn the ignition switch OFF, and then ON.

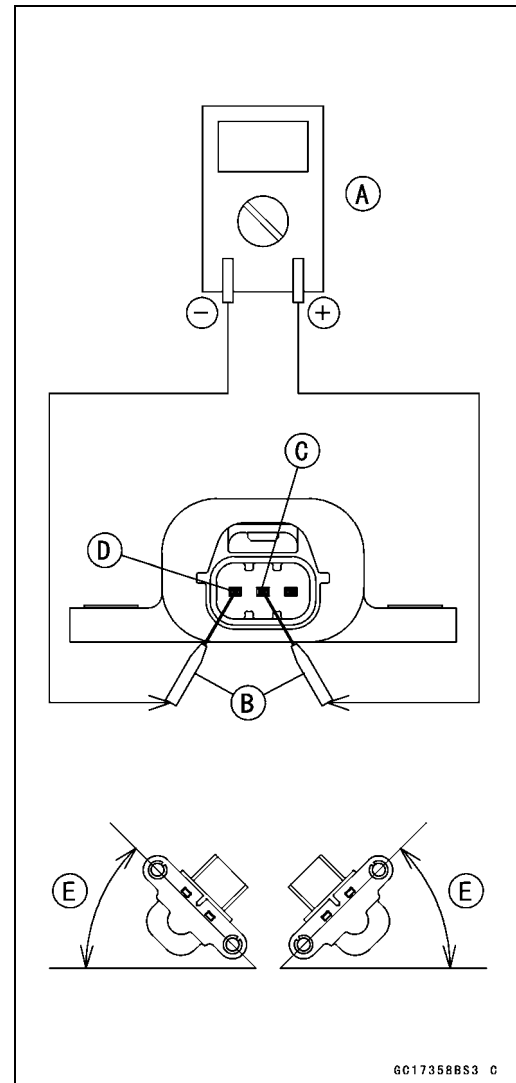

GC17358BS3 C

- Turn the ignition switch OFF.
- Remove the needle adapter set, and apply silicone sealant to the seals of the connector for waterproofing.
- Sealant - Kawasaki Bond (Silicone Sealant): 56019-120**
- ★ If the output voltage is out of the specified, replace the vehicle-down sensor.

Vehicle-down Sensor (Service Code 31)

Vehicle-down Sensor Circuit

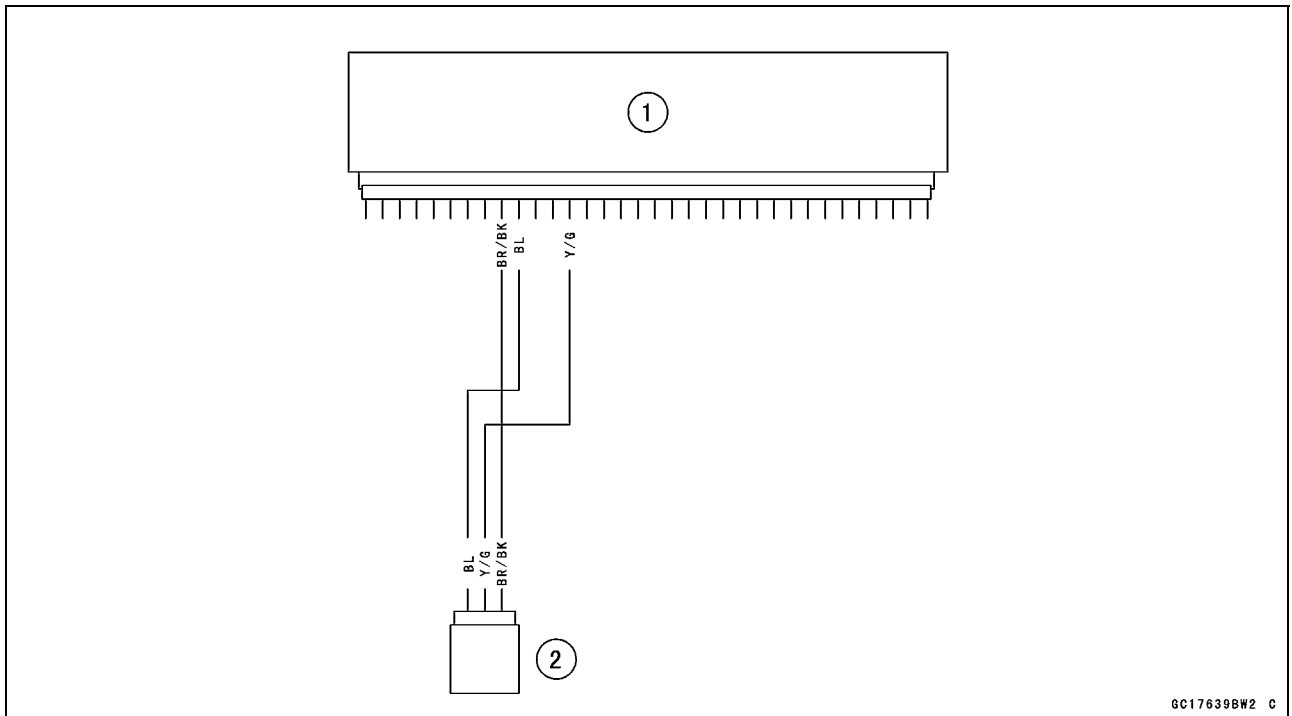

- 1. ECU
- 2. Vehicle-down Sensor

## 3-70 FUEL SYSTEM (DFI)

### Subthrottle Sensor (Service Code 32)

#### Subthrottle Sensor Removal/Adjustment

##### CAUTION

Do not remove or adjust the subthrottle sensor [A] since it has been adjusted and set with precision at the factory.

Never drop the throttle body assy, especially on a hard surface. Such a shock to the sensor can damage it.

Subthrottle Sensor Connector [B]

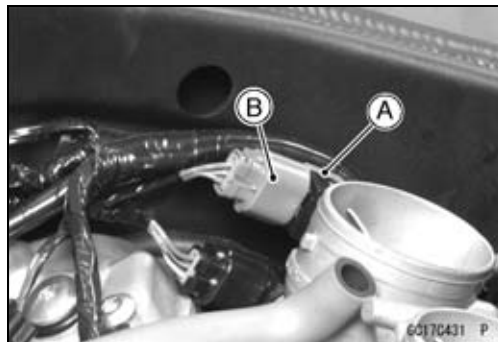

#### Subthrottle Sensor Input Voltage Inspection

##### NOTE

○ Be sure the battery is fully charged.

- Turn the ignition switch OFF.
- Remove the ECU (see ECU Removal). Do not disconnect the ECU connectors.
- Connect a digital voltmeter [A] to the connector [B], using the needle adapter set.

**Special Tool - Needle Adapter Set: 57001-1457**

##### Subthrottle Sensor Input Voltage

###### Connections to ECU Connector

Meter (+) → BL lead (terminal 10)

Meter (-) → BR/BK lead (terminal 28)

- Measure the input voltage with the engine stopped, and with the connectors joined.
- Turn the ignition switch ON.

##### Input Voltage at ECU Connector

**Standard: DC 4.75 ~ 5.25 V**

- Turn the ignition switch OFF.
- ★ If the reading of input voltage is less than the standard, check the ECU for its ground, power supply and wiring shorted.
- ★ If the input voltage is within the standard range, check the input voltage at the subthrottle sensor connector.
- Remove:
  - Air Cleaner Housing (see Air Cleaner Housing Removal)
  - Fuel Pump Lead Connector (see Fuel Tank Removal)

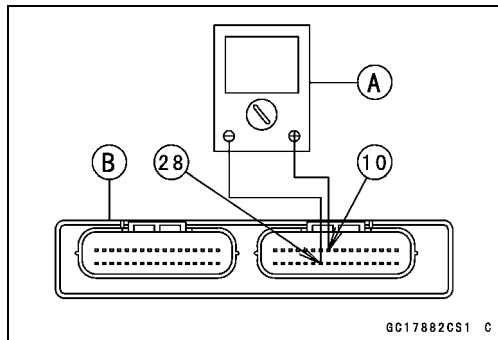



**Subthrottle Sensor (Service Code 32)**

- Disconnect the subthrottle sensor connector [A] and connect the setting adapter [B] between the harness connector and sub throttle sensor connector.
- Connect a digital meter to the setting adapter leads.

**Special Tool - Throttle Sensor Setting Adapter: 57001-1538**

**Subthrottle Sensor Input Voltage**

**Connections to Sensor**

- Meter (+) → BL lead
- Meter (-) → BR/BK lead

- Install the throttle body assy (see Throttle Body Assy Installation).
- Measure the sensor input voltage with the engine stopped, and with the connector joined.
- Turn the ignition switch ON.

**Input Voltage at Sensor**

**Standard: DC 4.75 ~ 5.25 V**

- Turn the ignition switch OFF.
- ★ If the reading is out of the range, check the wiring (see wiring diagram).
- ★ If the reading is good, check the output voltage of the sensor.

**Subthrottle Sensor Output Voltage Inspection**

- Measure the output voltage at the ECU in the same way as input voltage inspection.
- Digital Voltmeter [A]
- Connectors [B]

**Special Tool - Needle Adapter Set: 57001-1457**

**Subthrottle Sensor Output Voltage**

**Connections to ECU**

- Meter (+) → BR lead (terminal 24)
- Meter (-) → BR/BK lead (terminal 28)

- Turn the ignition switch ON.
- Measure the output voltage when the subthrottle valve is fully opened or completely closed.

**Output Voltage at ECU**

**Standard: DC 1.08 ~ 4.60 V (at subthrottle valve full opening to closing)**

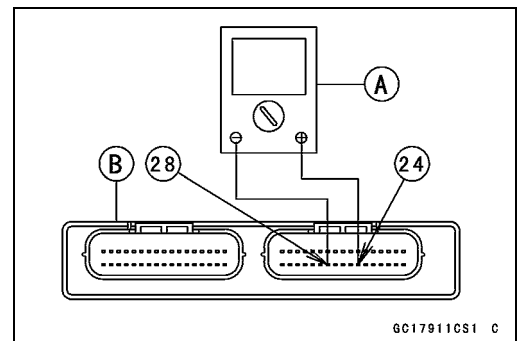
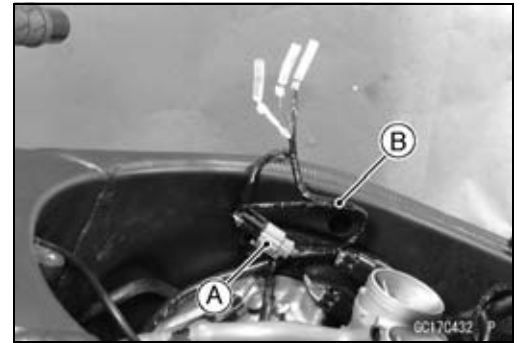

**CAUTION**

**Do not remove or adjust the subthrottle sensor. It has been adjusted and set with precision at the factory.**

**Never drop the throttle body assy can especially on a hard surface. A shock to the sensor can damage it.**

## 3-72 FUEL SYSTEM (DFI)

### Subthrottle Sensor (Service Code 32)

- ★ If the output voltage is within the standard range, check the ECU for a good ground, and power supply (see ECU Power Supply Inspection). If the ground and power supply are good, replace the ECU (see ECU Removal/Installation).
- ★ If the output voltage is far out of the standard range (e.g. when the wiring is open, the reading is 0 V.), check the output voltage again at the sensor connector.
- Disconnect the subthrottle sensor connector [A] and connect the setting adapter [B] between the harness connector and subthrottle sensor connector.
- Connect a digital meter to the setting adapter leads.

**Special Tool - Throttle Sensor Setting Adapter: 57001-1538**

#### Subthrottle Sensor Output Voltage

##### Connections to Sensor

Meter (+) → BR lead

Meter (-) → BR/BK lead

- Measure the sensor output voltage with the engine stopped, and with the connector joined.
- Turn the ignition switch ON.
- Measure the output voltage when the subthrottle valve is fully opened or completely closed.

#### Output Voltage at Sensor

**Standard: DC 1.08 ~ 4.60 V (at subthrottle valve full opening to closing)**

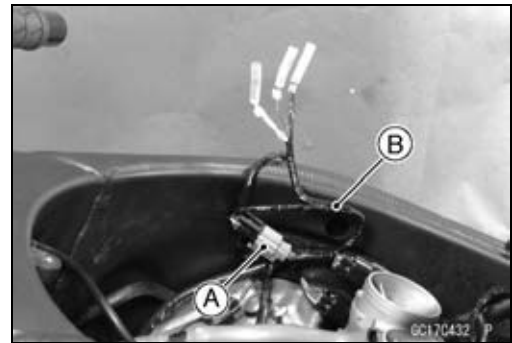

#### CAUTION

**Do not remove or adjust the subthrottle sensor. It has been adjusted and set with precision at the factory.**

**Never drop the throttle body assy, especially on a hard surface. A shock to the sensor can damage it.**

- After subthrottle sensor voltage inspection, remove the harness adapter.
- ★ If the reading is out of the standard range, inspect the throttle sensor resistance.
- ★ If the output voltage is normal, check the wiring for continuity (see wiring diagram).

**Subthrottle Sensor (Service Code 32)**

**Resistance Inspection**

- Turn the ignition switch OFF.
- Disconnect the subthrottle sensor connector.
- Connect a digital meter [A] to the subthrottle sensor connector [B].
- Measure the subthrottle sensor resistance.

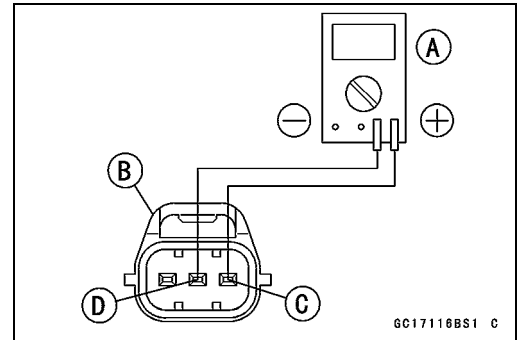

**Subthrottle Sensor Resistance**

**Connections:** BL lead [C] ↔ BR/BK lead [D]

**Standard:** 4 ~ 6 kΩ

- ★ If the reading is out of the range, replace the throttle body assy (see Throttle Body Assy Removal/Installation).
- ★ If the reading is within the range, but the problem still exists, replace the ECU (see ECU Removal/Installation).

**Subthrottle Sensor Circuit**

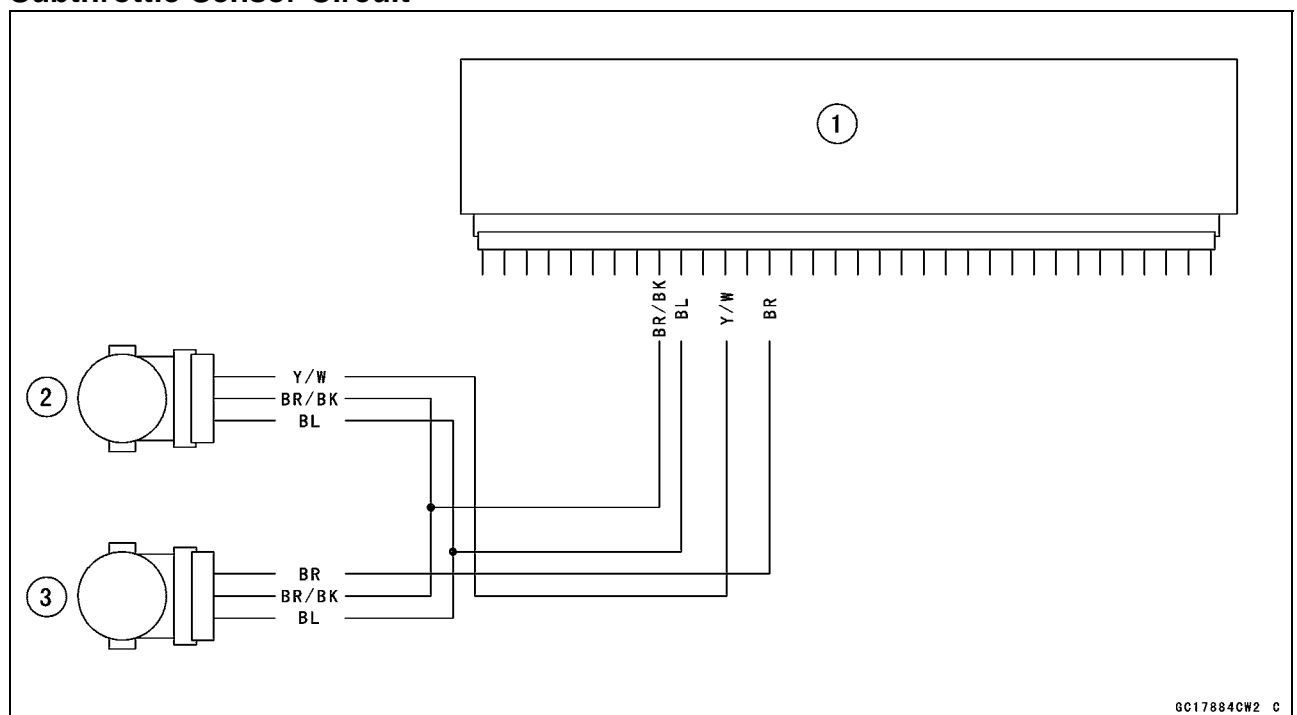

1. ECU
2. Main Throttle Sensor
3. Subthrottle Sensor

## 3-74 FUEL SYSTEM (DFI)

### Oxygen Sensor-not activated (#1, #2: Service Code 33, 83)-Equipped Models

Oxygen Sensor #1: Service Code 33

Oxygen Sensor #2: Service Code 83

#### Oxygen Sensor Removal/Installation

- Refer to Oxygen Sensor Removal and Installation in the Electrical System chapter (see Oxygen Sensor Removal in the Electrical System chapter).

#### Oxygen Sensor Inspection

##### NOTE

- The oxygen sensor itself is the same for #1 [A] and #2 [B], but wiring of the main harness side is different.

- Warm up the engine thoroughly.
- Turn the ignition switch OFF.
- Remove the right middle fairing (see Right Middle Fairing Removal in the Frame chapter).
- Connect a digital voltmeter [A] to the each oxygen sensor connector [B] (sensor side), using the needle adapter set.

**Special Tool - Needle Adapter Set: 57001-1457**

#### Oxygen Sensor Output Voltage

##### Connections to Oxygen Sensor Connector

**Meter (+) → BK lead**

**Meter (-) → GY lead**

- Remove the air cleaner housing (see Air Cleaner Housing Removal).
- Remove the air switching valve hoses [A] (both sides) from the air suction valve cover.

- Insert the suitable plugs [A] (both sides) in the holes and shut off the secondary air.
- Reinstall the air cleaner housing (see Air Cleaner Housing Installation).
- Turn the ignition switch ON.
- Start the engine, and let it idle.
- Measure the output voltage of the sensor with the connector joined.

#### Oxygen Sensor Output Voltage (with Plugs)

**Standard: 0.45 ~ 2.5 V**

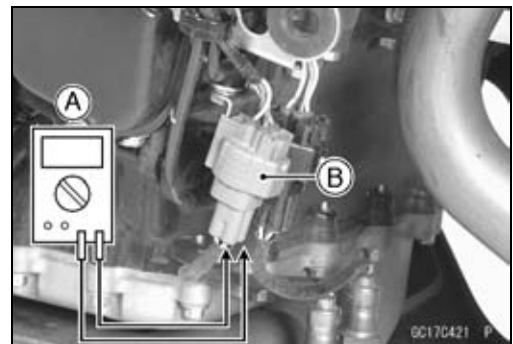
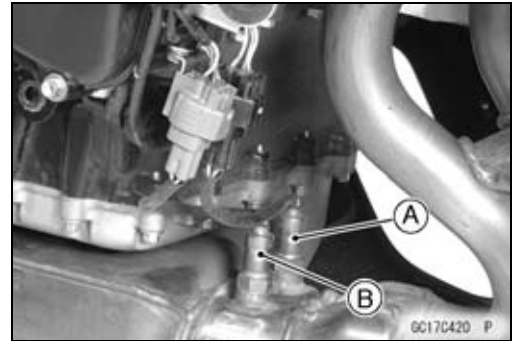

## Oxygen Sensor-not activated (#1, #2: Service Code 33, 83)-Equipped Models

- Next, remove the plugs [A] (both sides) from the fittings with idling.
- Measure the output voltage of the sensor with the connector joined.

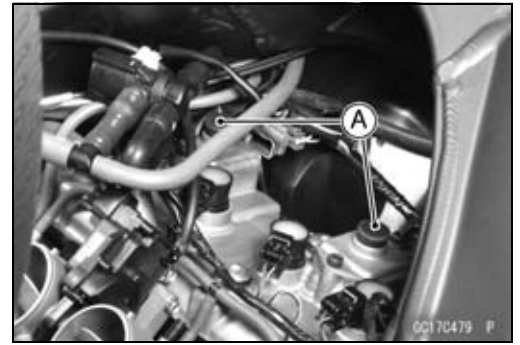

### Oxygen Sensor Output Voltage (without Plugs)

Standard: 0.05 ~ 0.45 V

- ★ If the reading is within range (with plugs: 0.45 ~ 2.5 V, without plugs: 0.05 ~ 0.45 V), the oxygen sensor is good.
- ★ If the reading is without range, replace the oxygen sensor.
- Remove the needle adapter set, and apply silicone sealant to the seals of the connector for waterproofing.

Sealant - Kawasaki Bond (Silicone Sealant): 56019-120

### Oxygen Sensor Circuit

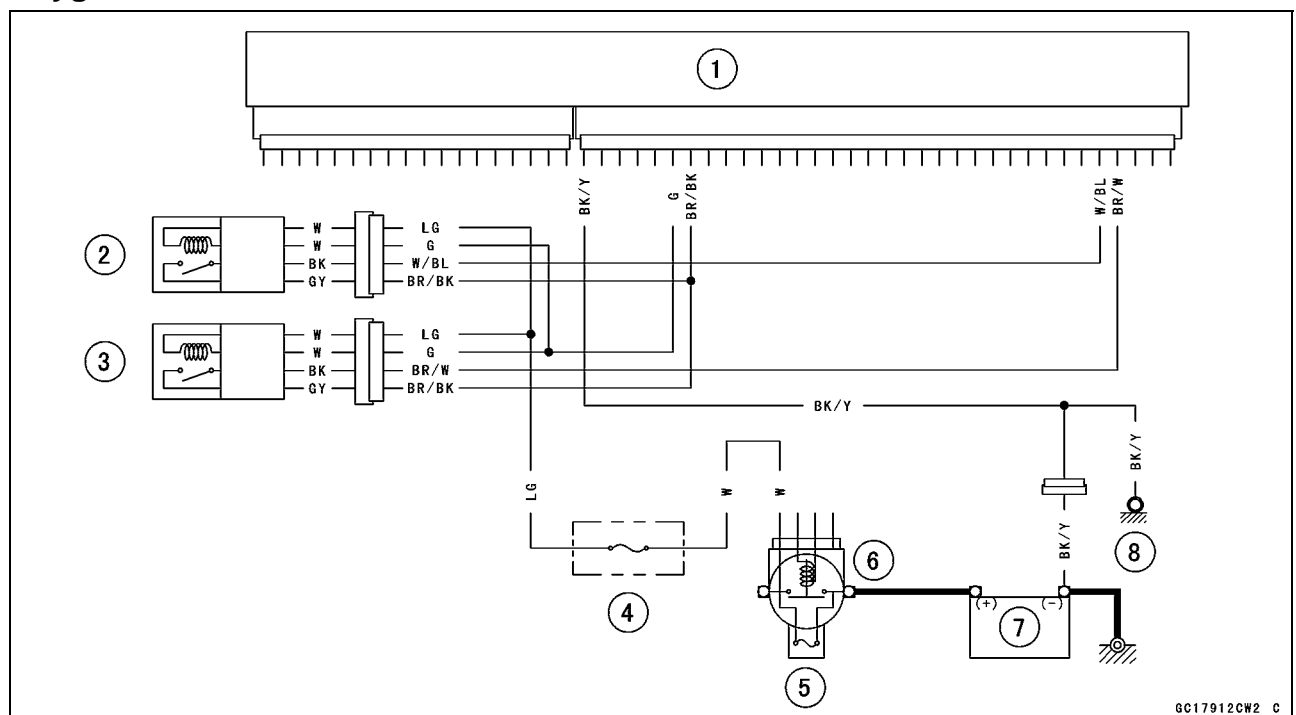

1. ECU
2. Oxygen Sensor #1
3. Oxygen Sensor #2
4. Oxygen Sensor Heater Fuse 10 A
5. Main Fuse 30 A
6. Starter Relay
7. Battery 12 V 8 Ah
8. Frame Ground

## 3-76 FUEL SYSTEM (DFI)

### Exhaust Butterfly Valve Actuator Sensor (Service Code 34)

#### Exhaust Butterfly Valve Actuator Sensor Removal/Installation

The exhaust butterfly valve actuator sensor is built in the exhaust butterfly valve actuator. So, the sensor itself can not be removed. Remove the exhaust butterfly valve actuator (see Exhaust Butterfly Valve Actuator Removal).

#### Exhaust Butterfly Valve Actuator Sensor Input Voltage Inspection

##### NOTE

○Be sure the battery is fully charged.

- Turn the ignition switch OFF.
- Remove:
  - Seat Cover (see Seat Cover Removal in the Frame chapter)
  - Exhaust Butterfly Valve Actuator (see Exhaust Butterfly Valve Actuator Removal)
- Disconnect the exhaust butterfly valve actuator sensor lead connector (3 pins connector) [A] and connect the setting adapter [B] between these connector.

**Special Tool - Throttle Sensor Setting Adapter #1: 57001-1400**

- Connect a digital meter to the setting adapter leads.

#### Exhaust Butterfly Valve Actuator Sensor Input Voltage Connections to Adapter:

**Digital Meter (+)** → Y/W (actuator W) lead

**Digital Meter (-)** → BK/BL (actuator BK) lead

- Measure the input voltage with the engine stopped and with the connector joined.
- Turn the ignition switch ON.

#### Input Voltage at Actuator

**Standard: DC 4.75 ~ 5.25 V**

- Turn the ignition switch OFF.
- ★ If the reading is within the standard, check the output voltage (see Exhaust Butterfly Valve Actuator Sensor Output Voltage Inspection).
- ★ If the reading is out of the standard, remove the ECU and check the wiring between these connectors.
- Disconnect the ECU and sensor connectors.

#### Wiring Connections

**ECU Connector [A]** ←→

**Exhaust Butterfly Valve Actuator Sensor Connector [B]**

**BL lead (ECU terminal 10) [C]**

**BR/BK lead (ECU terminal 28) [D]**

- ★ If the wiring is good, check the ECU for its ground and power supply (see ECU Power Supply Inspection).
- ★ If the ground and power supply are good, replace the ECU (see ECU Removal/Installation).

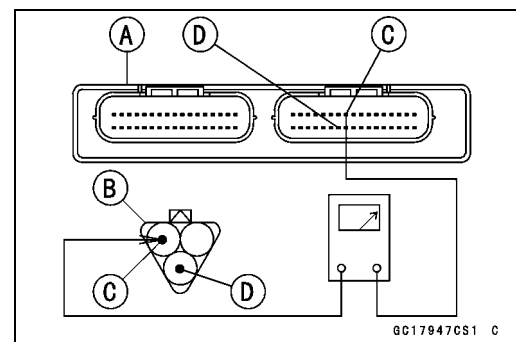

Exhaust Butterfly Valve Actuator Sensor (Service Code 34)

**Exhaust Butterfly Valve Actuator Sensor Output Voltage Inspection**

**NOTE**

○ Before this inspection, confirm the pulley [A] is original position (see Exhaust Butterfly Valve Actuator Installation).

- Remove:  
Exhaust Butterfly Valve Actuator (see Exhaust Butterfly Valve Actuator Removal)
- Disconnect:  
2 pins Connector [B]  
3 pins Connector [C]
- Connect the setting adapter [A] between the 3 pins connectors.  
**Special Tool - Throttle Sensor Setting Adapter #1: 57001-1400**
- Connect a digital meter to the setting adapter leads.

**Exhaust Butterfly Valve Actuator Sensor Output Voltage Connections to Adapter:**

- Digital Meter (+) → BL (actuator Y) lead**
- Digital Meter (-) → BK/BL (actuator BK) lead**

- Measure the output voltage at the 3 pins connector of the exhaust butterfly valve actuator when the pulley is original position.
- Turn the ignition switch ON.

**Output Voltage at Actuator**  
**Standard: DC 3.46 ~ 3.76 V at pulley original position**

- Turn the ignition switch OFF.
- ★ If the reading is out of the standard, check the exhaust butterfly valve actuator sensor resistance (see Exhaust Butterfly Valve Actuator Sensor Resistance Inspection).
- ★ If the reading is within the standard, remove the ECU and check the wiring between these connectors.
- Disconnect the ECU and sensor connectors.

**Wiring Connections**

- ECU Connector [A] ↔**
- Exhaust Butterfly Valve Actuator Sensor Connector [B]**
- R/BK lead (ECU terminal 5) [C]**
- BR/BK lead (ECU terminal 28) [D]**

- ★ If the wiring is good, check the ECU for its ground and power supply (see ECU Power Supply Inspection).
- ★ If the ground and power supply are good, replace the ECU (see ECU Removal/Installation).

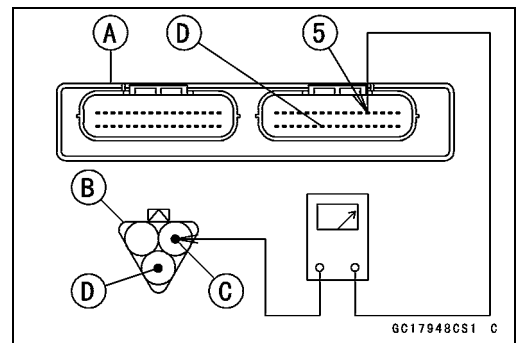
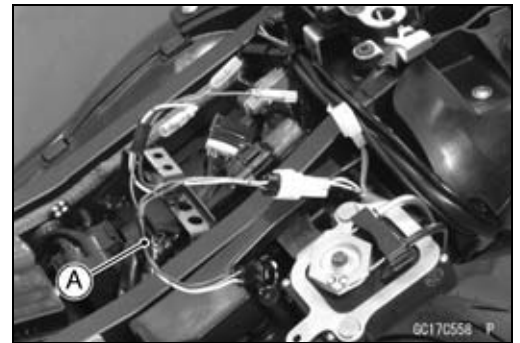
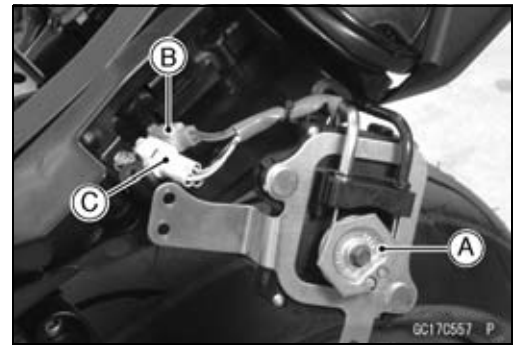

## 3-78 FUEL SYSTEM (DFI)

### Exhaust Butterfly Valve Actuator Sensor (Service Code 34)

#### Exhaust Butterfly Valve Actuator Sensor Inspection

- Remove:
  - Seat Cover (see Seat Cover Removal in the Frame chapter)
  - Bolts [A]
  - Screw [B]
- Pull out the exhaust butterfly valve actuator [C].

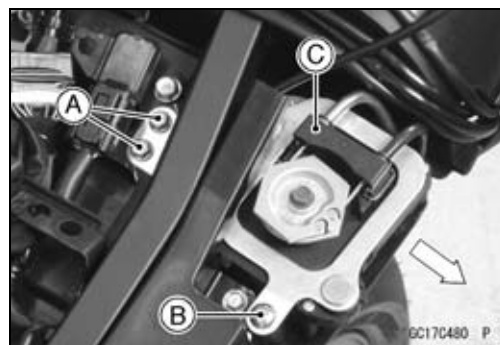

- Turn the ignition switch OFF.
- Disconnect the exhaust butterfly valve actuator sensor connector [A].
- Connect a digital meter [B] to the exhaust butterfly valve actuator sensor connector.
- Measure the exhaust butterfly valve actuator sensor resistance.

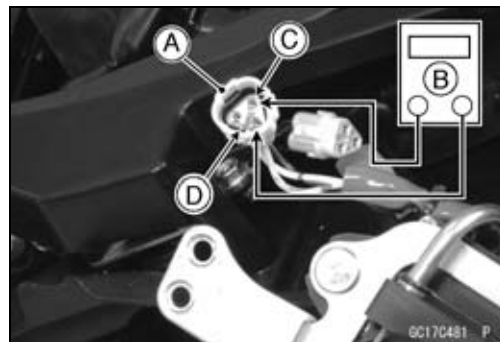

#### Exhaust Butterfly Valve Actuator Sensor Resistance

Connections: W lead [C] ↔ BK lead [D]

Standard: 4 ~ 6 kΩ

- ★ If the reading is out of the range, replace the exhaust butterfly valve actuator (see Exhaust Butterfly Valve Actuator Removal).

#### Exhaust Butterfly Valve Actuator Sensor Circuit

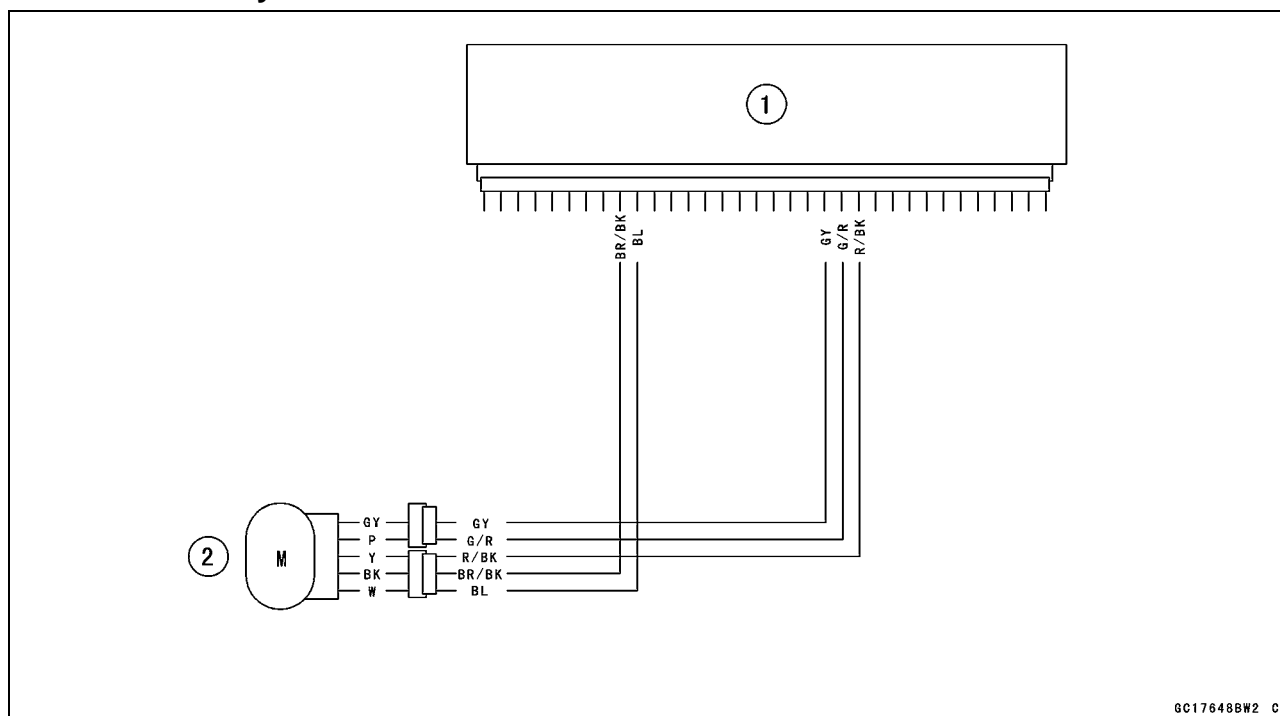

1. ECU

2. Exhaust Butterfly Valve Actuator



**Immobilizer Amplifier (Service Code 35)-Equipped Models**

**Antenna Resistance Inspection**

- Remove:
  - Left Inner Cover (see Inner Cove Removal in the Frame chapter)
- Disconnect:
  - Antenna Lead Connector [A]
- Measure the resistance of the antenna coil in the ignition switch as follows.

**Antenna Resistance**

**Connections to Antenna**

Meter (+) → R Lead

Meter (-) → R Lead

**Standard: About 0.6 ~ 0.9 Ω**

★If the resistance is out of the standard range, replace the ignition switch.

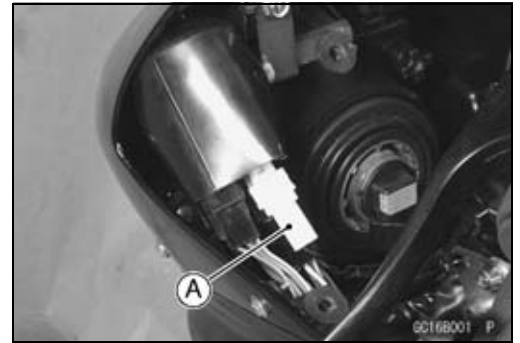

**Amplifier Input Voltage Inspection**

**NOTE**

○Be sure the battery is fully charged.

- Turn the ignition switch OFF.
- Remove:
  - Windshield (see Windshield Removal in the Frame chapter)
  - Immobilizer Amplifier (see Immobilizer System Parts Replacement in the Electrical System chapter)
- Connect a digital voltmeter to the connectors, using the needle adapter set.

**Special Tool - Needle Adapter Set: 57001-1457**

**Amplifier Input Voltage**

**Connections to Connectors**

Meter (+) → BR/W Lead [A]

Meter (-) → BK/Y Lead [B]

- Measure the input voltage DC with the connectors joined.
- Turn the ignition switch ON.

**Input Voltage**

**Standard: Battery Voltage (12.8 V or more)**

- Turn the ignition switch OFF.
- ★If the reading is out of the range, check the wiring (see Blank Key Detection Section).
- ★If the reading and antenna resistance are good, replace the amplifier (see Immobilizer System Parts Replacement in the Electrical System chapter).

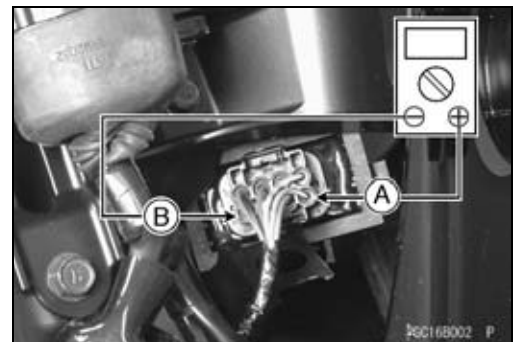

## 3-80 FUEL SYSTEM (DFI)

### Blank Key Detection (Service Code 36)

This code appears in the following conditions.

- The transponder [A] in the master and/or user key is malfunction.
- When the spare key of unregistration is used.
- When the master key is registered in the registered ECU. Therefore, the service code 36 will disappear when the above issue is solved.

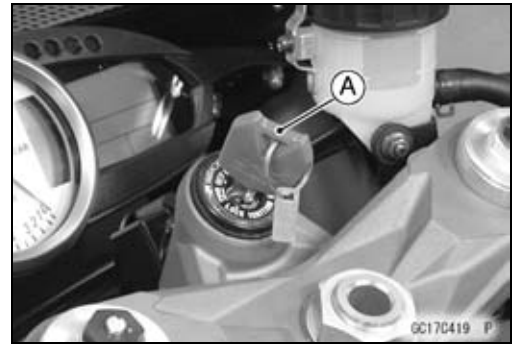

#### ***User Key Inspection***

- Register the user key correctly (see Key Registration in the Electrical System chapter).
- ★ If the service code 36 appears again, the transponder in the key is malfunction, replace it.

Blank Key Detection (Service Code 36)

Immobilizer System Circuit

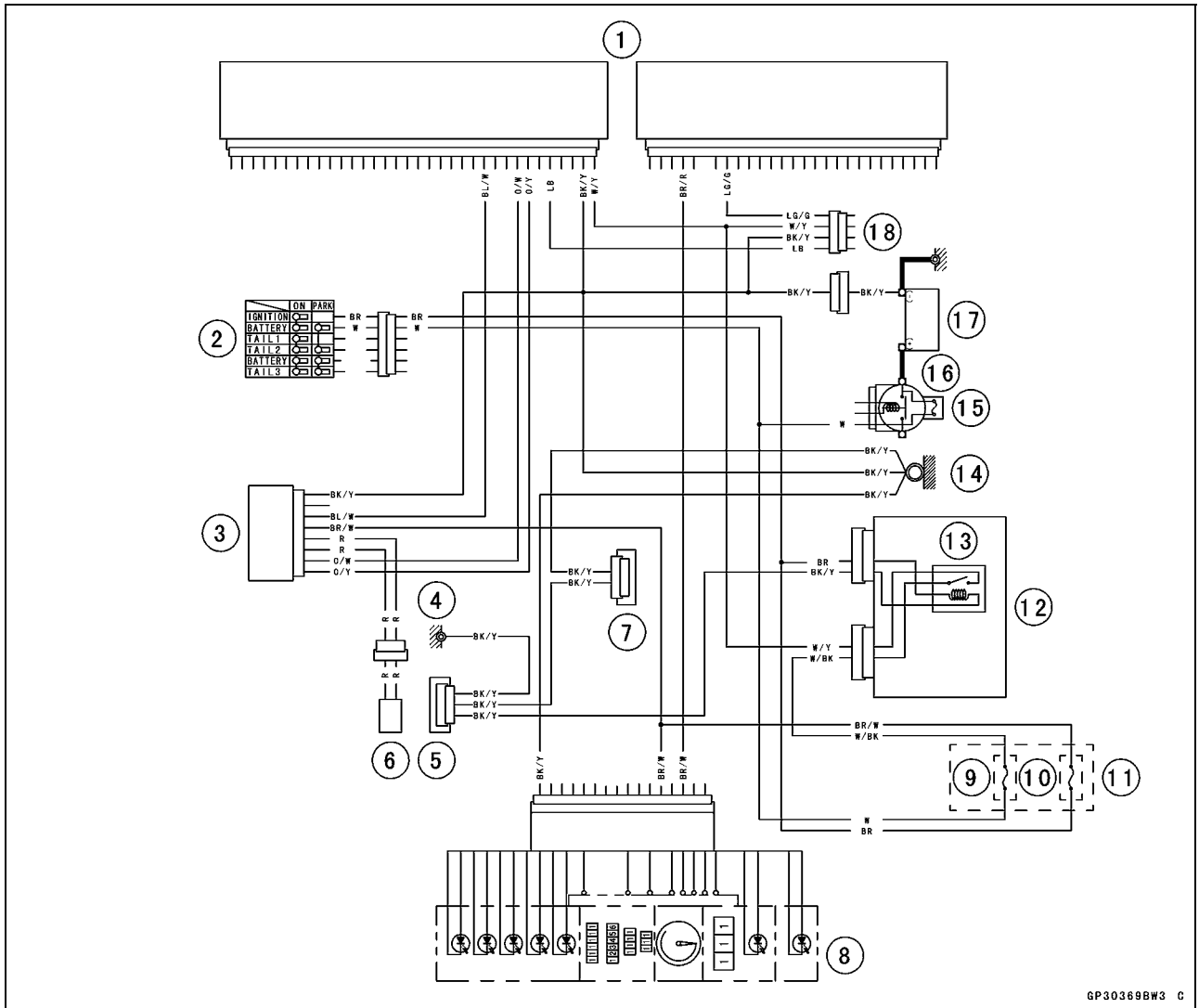

GP30369BW3 C

1. ECU
2. Ignition Switch
3. Immobilizer Amplifier
4. Cylinder Head Cover Ground
5. Joint Connector C
6. Immobilizer Antenna
7. Joint Connector B
8. Meter Unit
9. ECU Fuse 10 A
10. Ignition Fuse 10 A
11. Fuse Box
12. Relay Box
13. ECU Main Relay
14. Frame Ground
15. Main Fuse 30 A
16. Starter Relay
17. Battery 12 V 8 Ah
18. Immobilizer/Kawasaki Diagnostic System Connector

## 3-82 FUEL SYSTEM (DFI)

### ECU Communication Error (Service Code 39)

#### ECU Communication Line Inspection

- When the data is not sent from the ECU to the meter unit for more than about 10 seconds, the service code 39 is displayed.
- The service code 39 is detected with meter unit.
- Remove the ECU and meter unit, check the wiring between these connector.
- Disconnect the ECU and meter unit connectors.

#### Wiring Connections

ECU Connector [A] ↔ Meter Unit Connector [B]

BR/R lead [C]

- ★ If the wiring is good, check the meter unit (see Electrical Combination Meter Unit Inspection in the Electrical System chapter).
- ★ If the meter unit is normal, replace the ECU (see ECU Removal/Installation).

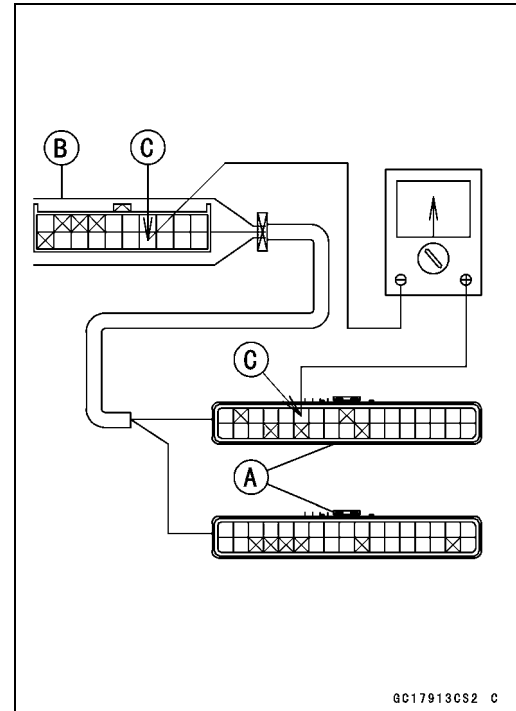

#### ECU Communication Line Circuit

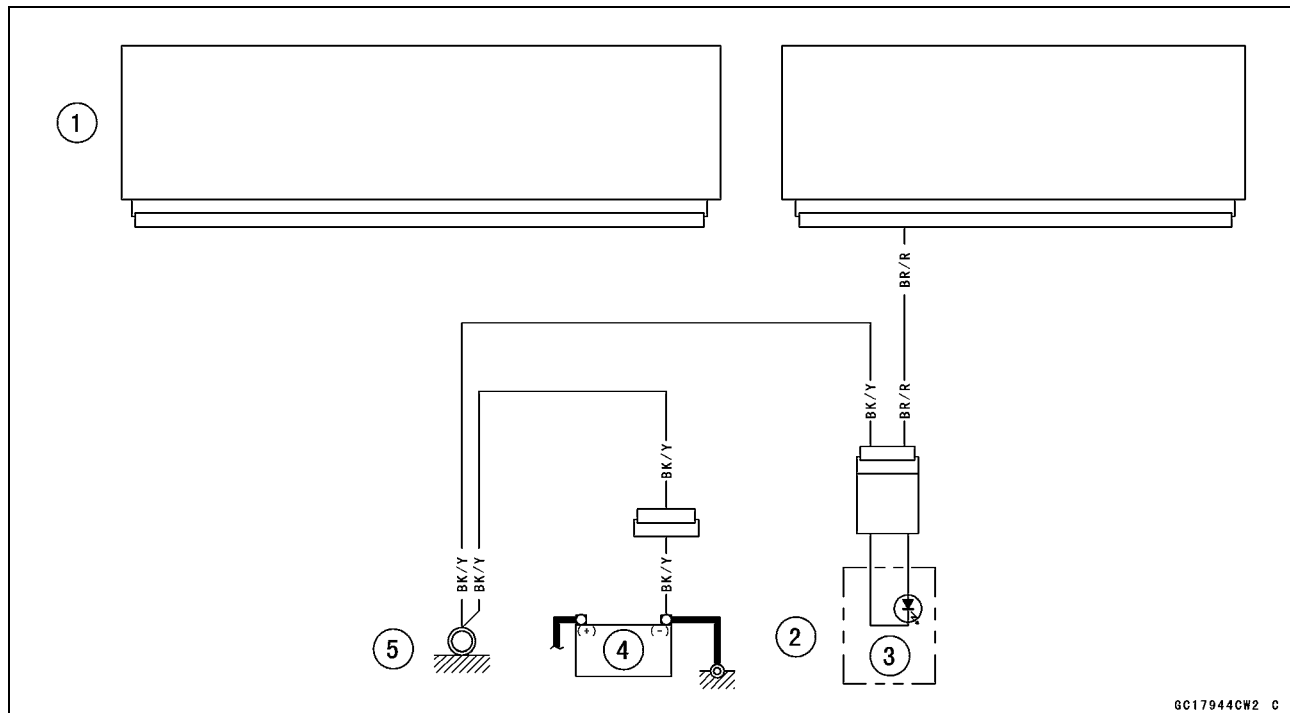

1. ECU
2. Meter Unit
3. Warning Indicator Light (LED)
4. Battery 12 V 8 Ah
5. Frame Ground

**Stick Coils #1, #2, #3, #4: (Service Code 51, 52, 53, 54)**

- Stick Coil #1: Service Code 51
- Stick Coil #2: Service Code 52
- Stick Coil #3: Service Code 53
- Stick Coil #4: Service Code 54

**Stick Coil Removal/Installation**

**CAUTION**

**Never drop the stick coils, especially on a hard surface. Such a shock to the stick coil can damage it.**

- Refer to the Stick Coil Removal/Installation in the Electrical System chapter.

**Stick Coil Input Voltage Inspection**

**NOTE**

○ Be sure the battery is fully charged.

- Turn the ignition switch OFF.
- Remove the ECU (see ECU Removal). Do not disconnect the ECU connector.
- Connect a digital voltmeter [A] to the connector of the ECU [B], with the needle adapter set.

**Special Tool - Needle Adapter Set: 57001-1457**

- Measure the input voltage to each primary winding of the ignition coils with the engine stopped, and with the connectors joined.
- Turn the ignition switch ON.

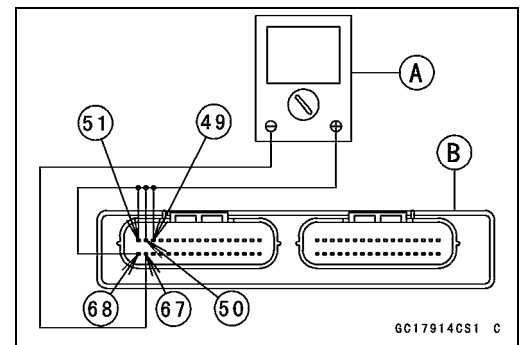

**Stick Coil Input Voltage at ECU**

**Connections for Stick Coil #1**

- Meter (+) → BK lead (terminal 51)
- Meter (-) → BK/Y lead (terminal 67)

**Connections for Stick Coil #2**

- Meter (+) → BK/G lead (terminal 50)
- Meter (-) → BK/Y lead (terminal 67)

**Connections for Stick Coil #3**

- Meter (+) → BK/W lead (terminal 49)
- Meter (-) → BK/Y lead (terminal 67)

**Connections for Stick Coil #4**

- Meter (+) → BK/O lead (terminal 68)
- Meter (-) → BK/Y lead (terminal 67)

**Input Voltage at ECU**

**Standard: Battery Voltage (12.8 V or more)**

- ★ If the reading is out of the standard, check the wiring (see wiring diagram).
- ★ If the reading is good, the input voltage is normal. Crank the engine, and check the peak voltage of the stick coils (see Stick Coil Primary Peak Voltage Inspection in the Electrical System chapter) in order to check the primary coils.

# 3-84 FUEL SYSTEM (DFI)

## Stick Coils #1, #2, #3, #4: (Service Code 51, 52, 53, 54)

### Stick Coil Circuit

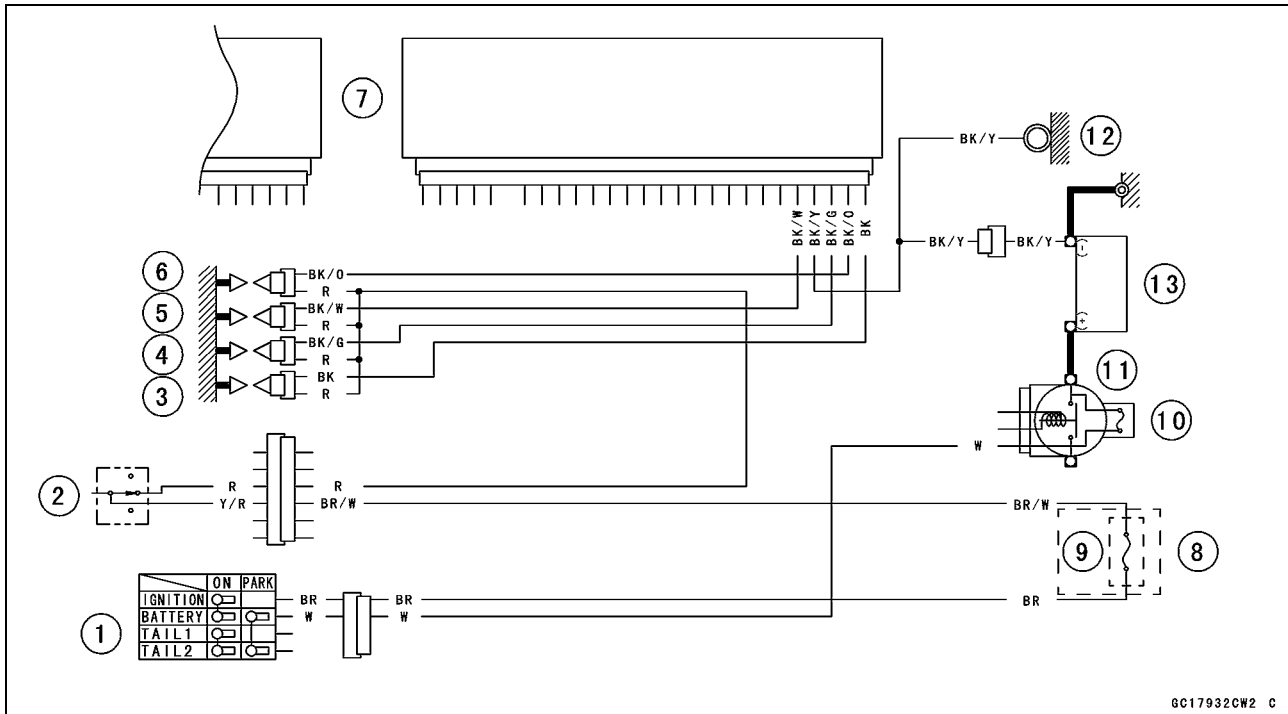

1. Ignition Switch
2. Engine Stop Switch
3. Stick Coil #1
4. Stick Coil #2
5. Stick Coil #3
6. Stick Coil #4
7. ECU
8. Fuse Box
9. Ignition Fuse 10 A
10. Starter Relay
11. Main Fuse 30 A
12. Frame Ground
13. Battery 12 V 8 Ah

---

**Radiator Fan Relay (Service Code 56)**

---

***Radiator Fan Relay Removal/Installation***

- The radiator fan relay is built in the relay box [A].
- Refer to the Relay Box Removal in the Electrical System chapter.

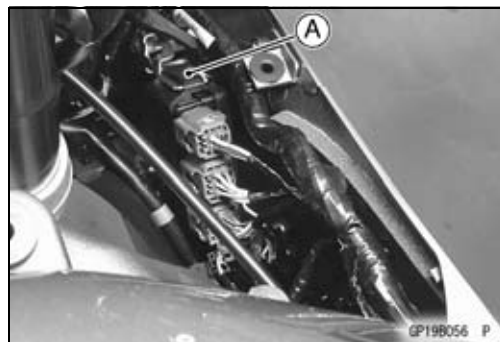
***Radiator Fan Relay Inspection***

- Refer to the Relay Circuit Inspection in the Electrical System chapter.
- ★If the radiator fan relay is normal, check the wiring for continuity.
- ★If the wiring is good, check the ECU for its ground and power supply (see ECU Power Supply Inspection).
- ★If the ground and power supply are good, replace the ECU (see ECU Removal/Installation).

# 3-86 FUEL SYSTEM (DFI)

## Radiator Fan Relay (Service Code 56)

### Radiator Fan Relay Circuit

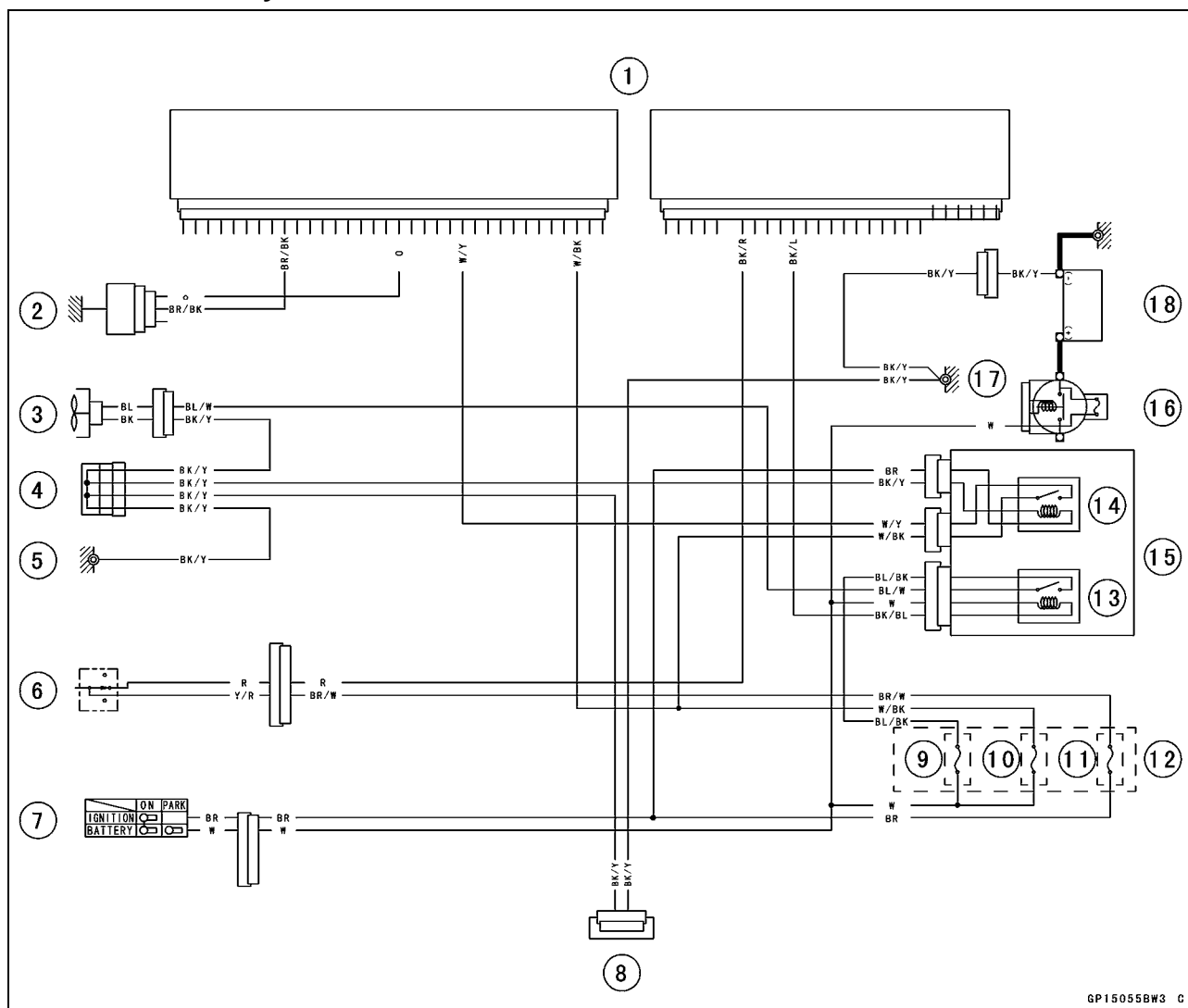

GP15055BW3 C

- |                               |                        |
|-------------------------------|------------------------|
| 1. ECU                        | 10. ECU Fuse 10 A      |
| 2. Water Temperature Sensor   | 11. Ignition Fuse 10 A |
| 3. Radiator Fan               | 12. Fuse Box           |
| 4. Joint Connector C          | 13. Radiator Fan Relay |
| 5. Cylinder Head Cover Ground | 14. ECU Main Relay     |
| 6. Engine Stop Switch         | 15. Relay Box          |
| 7. Ignition Switch            | 16. Main Fuse 30 A     |
| 8. Joint Connector B          | 17. Frame Ground       |
| 9. Radiator Fan Fuse 15 A     | 18. Battery 12 V 8 Ah  |



**Subthrottle Valve Actuator (Service Code 62)**

**Subthrottle Valve Actuator Removal**

**CAUTION**

Do not remove the subthrottle valve actuator [A] since it has been adjusted and set with precision at the factory.  
 Never drop the throttle body assy, especially on a hard surface. Such a shock to the actuator can damage it.

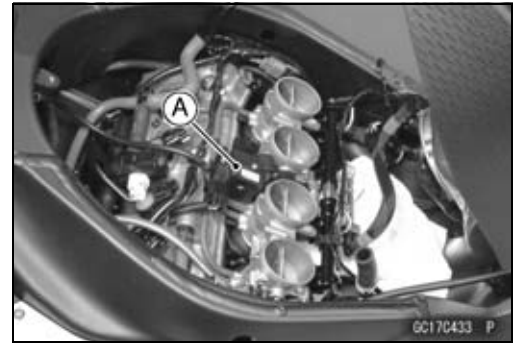

**Subthrottle Valve Actuator Inspection**

- Remove:
  - Air Cleaner Housing (see Air Cleaner Housing Removal)
  - Fuel Pump Lead Connector (see Fuel Tank Removal)
- Turn the ignition switch ON.
- Check to see that all subthrottle valves [A] open and close smoothly.
- ★ If the subthrottle valves do not operate, check the actuator internal resistance (see Resistance Inspection).



**Subthrottle Valve Actuator Resistance Inspection**

- Turn the ignition switch OFF.
- Remove the subthrottle valve actuator connector [A].



- Connect a digital meter to the connector [A].
- Measure the subthrottle valve actuator resistance.

**Subthrottle Valve Actuator Resistance**

Connections: G lead [1] ↔ W/BL lead [3]  
 BK/BL lead [2] ↔ P/BL lead [4]

Standard: About 5 ~ 7 Ω

- ★ If the reading is out of the range, replace the throttle body assy (see Throttle Body Assy Removal).
- ★ If the reading is within the range, check the input voltage (see Input Voltage Inspection).

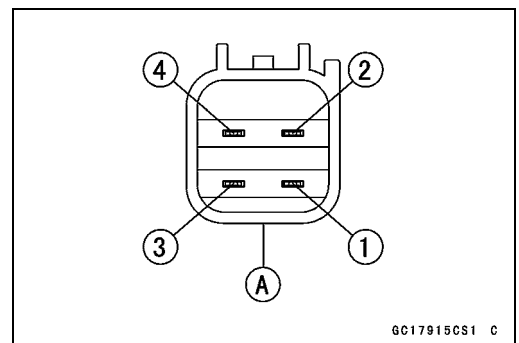

GC17915CS1 C

## 3-88 FUEL SYSTEM (DFI)

### Subthrottle Valve Actuator (Service Code 62)

#### Subthrottle Valve Actuator Input Voltage Inspection

##### NOTE

○Be sure the battery is fully charged.

- Turn the ignition switch OFF.
- Connect the peak voltage adapter [A] and a digital meter [B] to the connector [C], using the needle adapter set [D].

**Special Tools - Peak Voltage Adapter: 57001-1415**  
**Type: KEK-54-9-B**  
**Needle Adapter Set: 57001-1457**

#### Subthrottle Valve Actuator Input Voltage Connections to Harness Connector

- (I) Meter (+) → G lead [1]  
Meter (-) → W/BL lead [3]
- (II) Meter (+) → BK/BL lead [2]  
Meter (-) → P/BL lead [4]

- Measure the actuator input voltage with the engine stopped, and with the connector joined.
- Turn the ignition switch ON.

#### Input Voltage at Sensor

**Standard: About DC 8.5 ~ 10.5 V**

- ★ If the reading is out of the range, check the wiring to ECU.
- ★ If the wiring is good, replace the ECU (see ECU Removal).

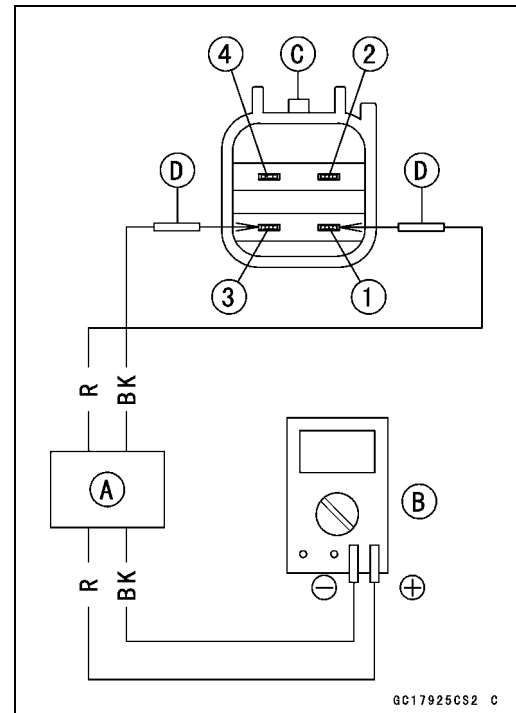

#### Subthrottle Valve Actuator Circuit

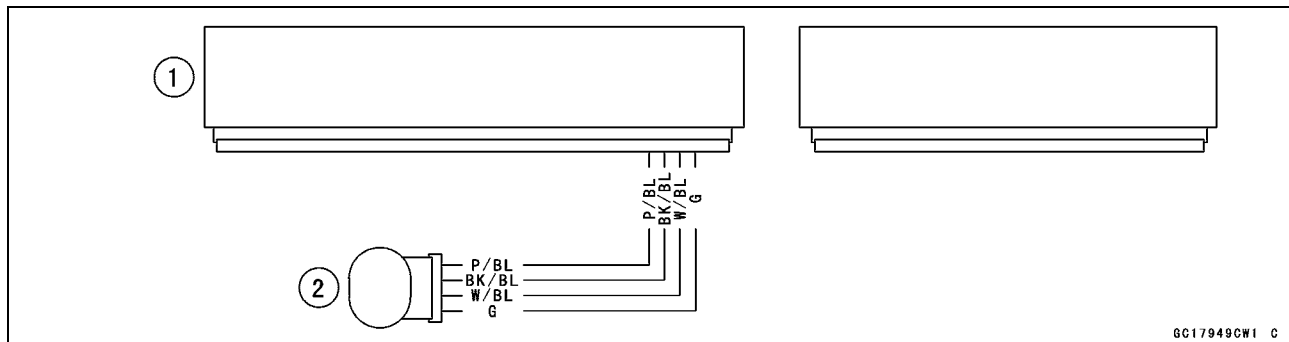

1. ECU
2. Subthrottle Valve Actuator

**Exhaust Butterfly Valve Actuator (Service Code 63)**

**Exhaust Butterfly Valve Actuator Removal**

- Remove:
  - Seat Cover (see Seat Cover Removal in the Frame chapter)
- Put off the rubber boots of exhaust butterfly valve cables.
- Loosen the locknuts [A] and adjuster nut [B].
- Screw in both adjusters until no adjusting the adjuster.

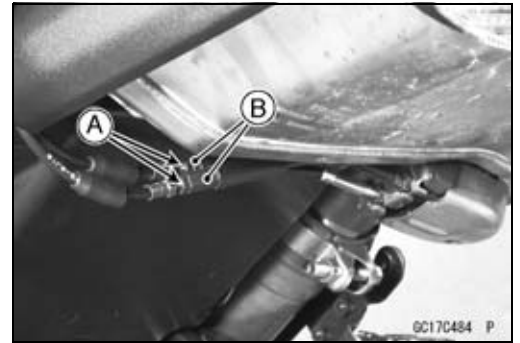

- Remove:
  - Bolts [A]
  - Screw [B]
- Pull out the exhaust butterfly valve actuator [C].

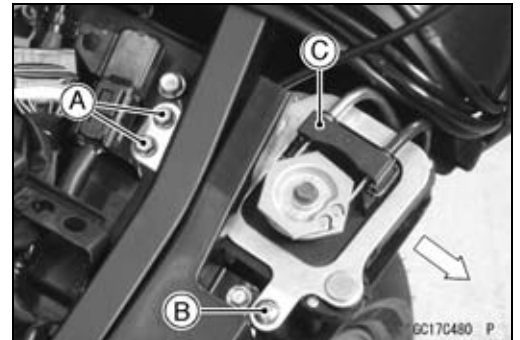

- Remove:
  - Clamp [A]
  - Exhaust Butterfly Valve Cables [B]
  - Connectors [C]
- Remove the exhaust butterfly valve actuator [D] with bracket [E].

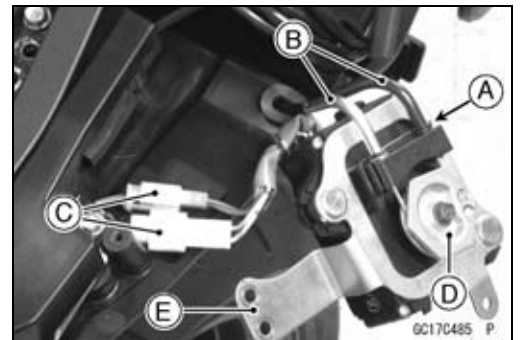

- Remove:
  - Exhaust Butterfly Valve Actuator Pulley [A].
  - Hold the pulley with a suitable tool [B].

**CAUTION**

**If the pulley bolt is removed without holding, the actuator damage will occur.**

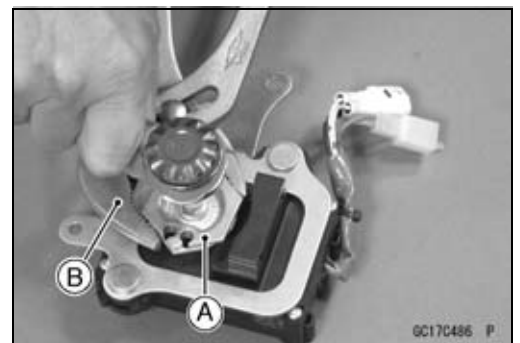

**Exhaust Butterfly Valve Actuator Installation**

- Install the bracket [A] on the actuator [B].
  - Washers [C]
  - Nuts [D]
- Tighten:
  - Torque - Exhaust Butterfly Valve Actuator mounting Nuts: 6.9 N·m (0.70 kgf·m, 61 in·lb)

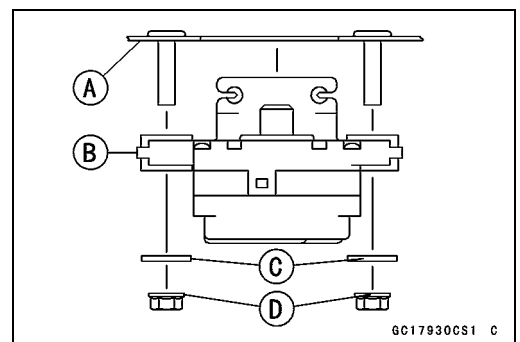

## 3-90 FUEL SYSTEM (DFI)

### Exhaust Butterfly Valve Actuator (Service Code 63)

- Fit the hole side [A] of the pulley to the groove side [B] of the actuator.

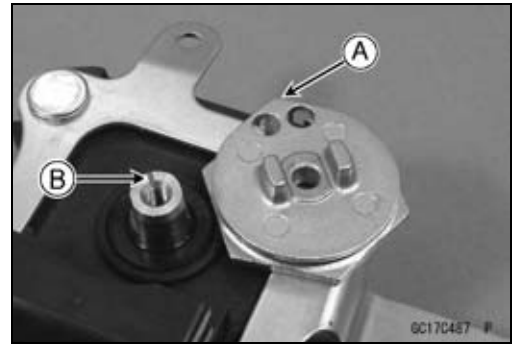

- Install the pulley [A] on the actuator.
- Hold the pulley with a suitable tool [B] and tighten the bolt.  
Torque - Exhaust Butterfly Valve Actuator Pulley Bolt: 4.9 N·m (0.50 kgf·m, 43 in·lb)

#### CAUTION

If the pulley bolt is tightened without holding, the actuator damage will occur.

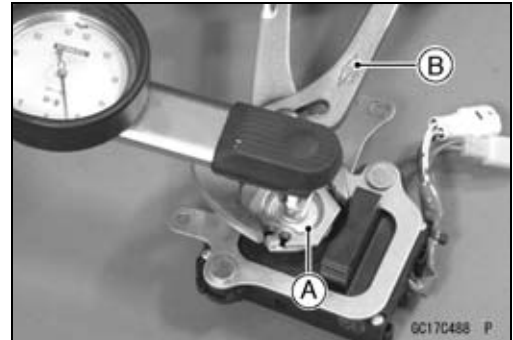

- Confirm the pulley angle [A] ( $41.7^\circ \pm 7^\circ$ ) as shown. It is original position of the pulley.

#### NOTE

○Correct the position electrically after confirming the use is discontinued, and there is no damage when differing from the angle of shown in the figure.

#### CAUTION

Do not correct the pulley position with the tool, forcibly. The actuator damage will occur.

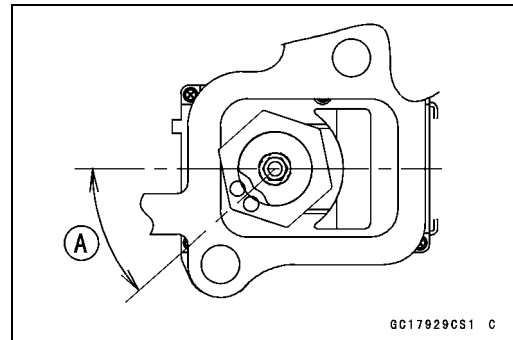

- ★If the angle is not within the specified angle, adjust the actuator as follows.
  - Connect the actuator connectors.
  - Turn the ignition switch ON.
  - Confirm the pulley turns clockwise and then counterclockwise.
  - The position is original position of the pulley.
  - Turn the ignition switch OFF.
- ★If the position is not within the specified angle above, replace the exhaust butterfly valve actuator.
- Tighten the exhaust butterfly valve actuator mounting bolts.
- Install the open cable first and then close cable (see Exhaust Butterfly Valve Cable Installation in the Engine Top End chapter).

**Exhaust Butterfly Valve Actuator (Service Code 63)**

**Exhaust Butterfly Valve Actuator Inspection**

**NOTE**

○Be sure to the battery in fully charged.

- Remove:
  - Seat Cover (see Seat Cover Removal in the Frame chapter)
- Turn the ignition switch ON.
- Check to see the pulley [A] clockwise [B] and counter-clockwise [C] smoothly.
- The pulley turns clockwise and then counterclockwise, and clockwise again.
- ★ If the pulley does not operate, check the exhaust butterfly valve actuator output voltage.

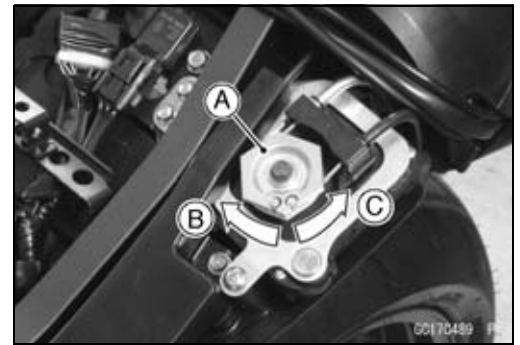

**Exhaust Butterfly Valve Actuator Output Voltage Inspection**

- Remove:
  - Seat Cover (see Seat Cover Removal in the Frame chapter)
  - Exhaust Butterfly Valve Actuator
- Measure the output voltage at the 3 pins connector of the exhaust butterfly valve actuator [A] when the pulley is original position as follows.
- Disconnect:
  - 2 pins Connector [B]
  - 3 pins Connector [C]
- Connect the adapter [D] between the 3 pins connectors and digital voltmeter [E].
  - Main Harness [F]

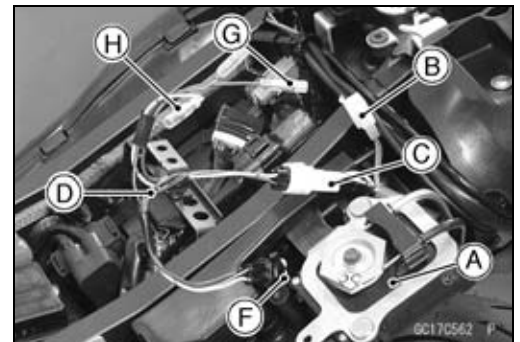

**Special Tool - Throttle Sensor Setting Adapter #1: 57001-1400**

**Connections**

**Meter (+) → BL Lead [G] in Adapter (Y Lead of Actuator)**

**Meter (-) → BK/BL Lead [H] in Adapter (BK Lead of Actuator)**

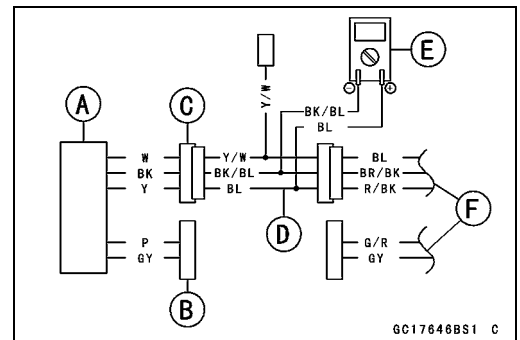

**Actuator Output Voltage (Pulley Original Position)**

**Standard: 3.46 ~ 3.76 V**

- ★ If the output voltage is out of the standard, remove the actuator and check the original position of pulley (see Exhaust Butterfly Valve Actuator Installation).

## 3-92 FUEL SYSTEM (DFI)

### Exhaust Butterfly Valve Actuator (Service Code 63)

#### Exhaust Butterfly Valve Actuator Circuit

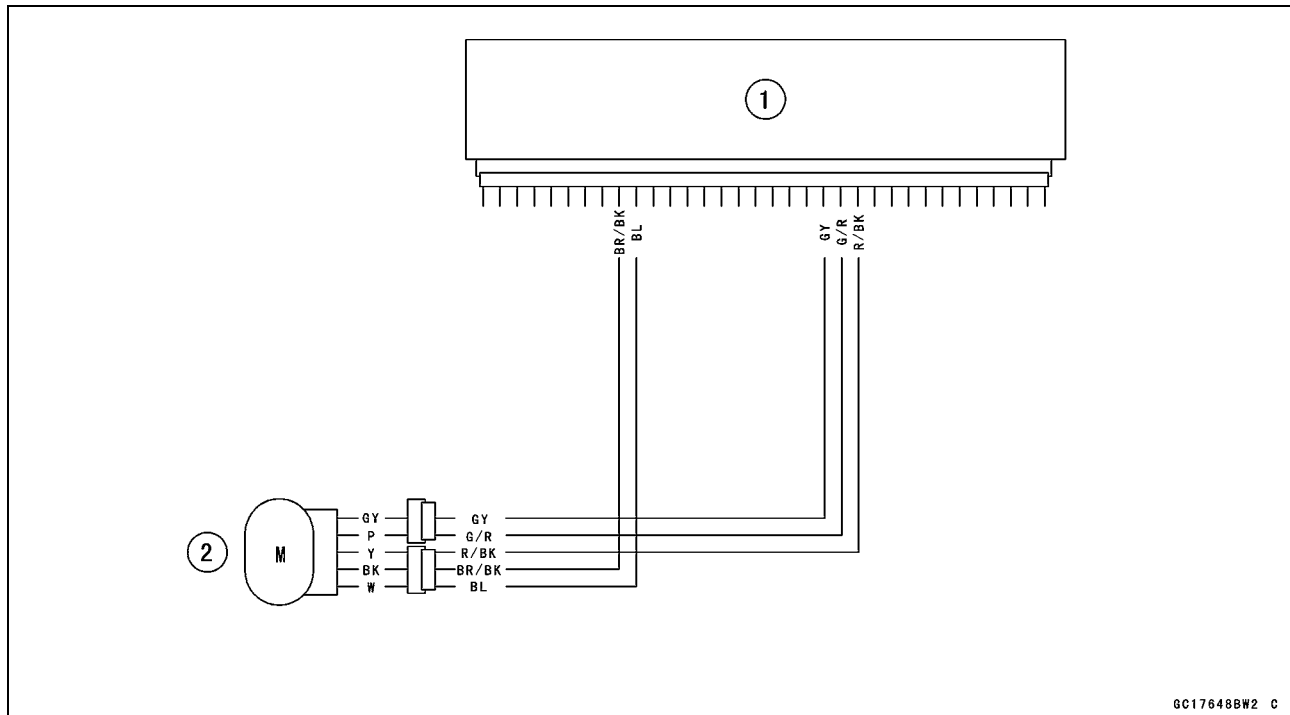

GC17648BW2 C

1. ECU

2. Exhaust Butterfly Valve Actuator

**Air Switching Valve (Service Code 64)**

**Air Switching Valve Removal/Installation**

- Refer to Clean Air System section in the Engine Top End chapter.

**Air Switching Valve Inspection**

- Refer to Air Switching Valve Unit Test in the Electrical System chapter.
- Check the wiring continuity, using the following diagram.

**Air Switching Valve Circuit (Other than Europe Models)**

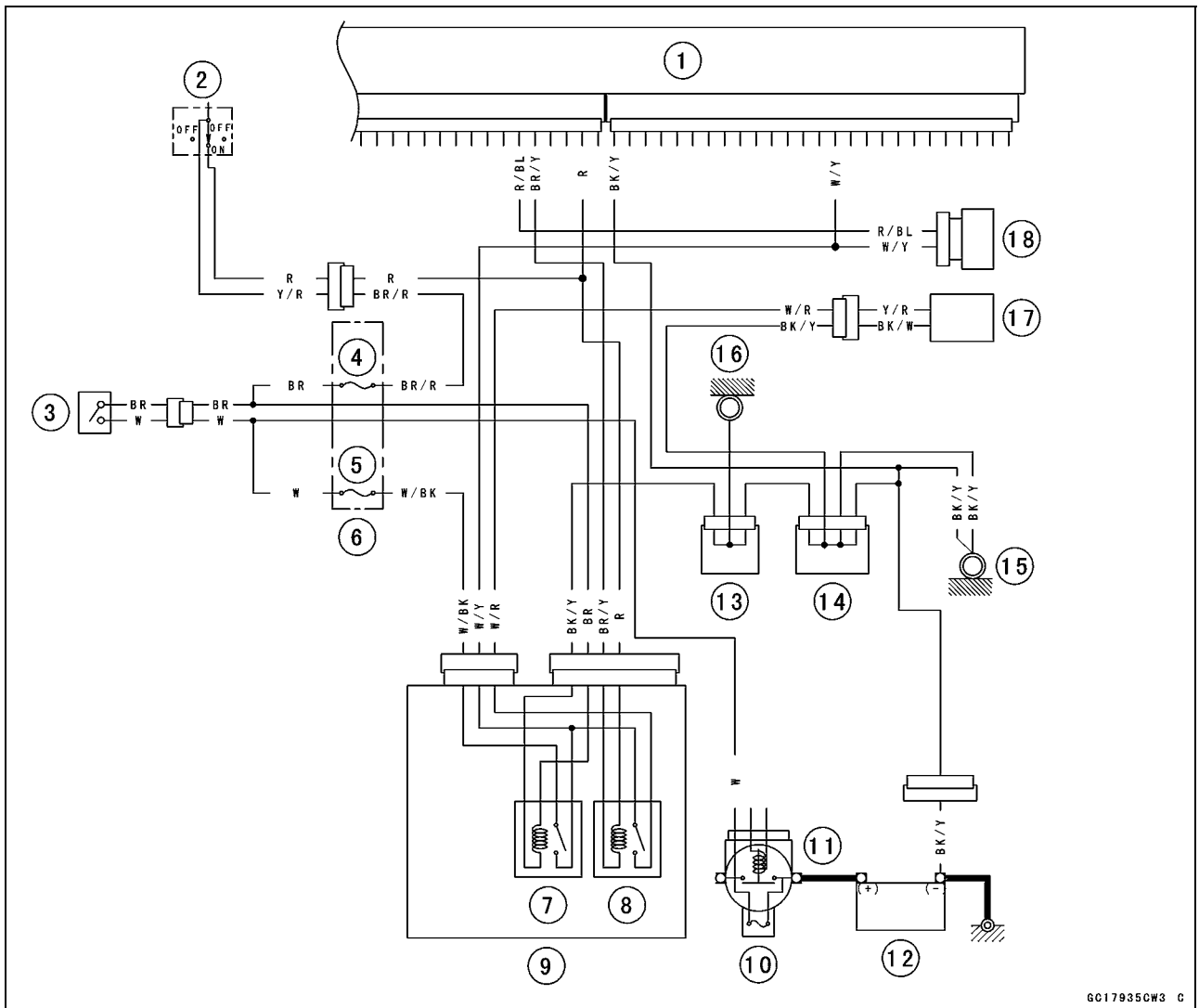

GC17935CW3 C

- |                       |                                |
|-----------------------|--------------------------------|
| 1. ECU                | 10. Main Fuse 30 A             |
| 2. Engine Stop Switch | 11. Starter Relay              |
| 3. Ignition Switch    | 12. Battery 12 V 8 Ah          |
| 4. Ignition Fuse 10 A | 13. Joint Connector C          |
| 5. ECU Fuse 10 A      | 14. Joint Connector B          |
| 6. Fuse Box           | 15. Frame Ground               |
| 7. ECU Main Relay     | 16. Cylinder Head Cover Ground |
| 8. Fuel Pump Relay    | 17. Fuel Pump                  |
| 9. Relay Box          | 18. Air Switching Valve        |

## 3-94 FUEL SYSTEM (DFI)

### Oxygen Sensor Heaters (#1, #2: Service Code 67)-Equipped Models

#### Oxygen Sensor Heater Removal/Installation

The oxygen sensor heater is built in the oxygen sensor. So, the heater itself can not be removed. Remove the oxygen sensor (see Oxygen Sensor Removal in the Electrical System chapter).

#### Oxygen Sensor Heater Inspection

- Remove:
  - Right Middle Fairing (see Right Middle Fairing Removal in the Frame chapter)
- Disconnect the each oxygen sensor lead connectors [A].



- Set the hand tester [A] to the  $\times 1 \Omega$  range and connect it to the terminals in the oxygen sensor lead connector [B].
  - White Lead Terminal [C]
  - White Lead Terminal [D]

**Special Tool - Hand Tester: 57001-1394**

#### Oxygen Sensor Resistance

**Standard: about  $8 \Omega$  at  $20^\circ\text{C}$  ( $68^\circ\text{F}$ )**

- ★ If the tester reading is not as specified, replace the oxygen sensor with a new one.
- ★ If the tester reading is specified, check the power source voltage Inspection.

#### NOTE

○ Be sure the battery is fully charged.

- Connect a digital meter [A] to each oxygen sensor connector [B], using the needle adapter [C].

**Special Tool - Needle Adapter Set: 57001-1457**

#### Oxygen Sensor Heaters Power Source Voltage

##### Connections to Oxygen Sensor Connector

Tester (+) → W (main harness side P/BK) lead [D]

Tester (-) → Battery (-) Terminal [E]

Oxygen Sensor #1 [F]

Oxygen Sensor #2 [G]

- Measure the power source voltage with the engine stopped, and with the oxygen sensor connector joined.
- Turn the ignition switch ON.

#### Power Source Voltage at Sensor Connector

**Standard: Battery Voltage**

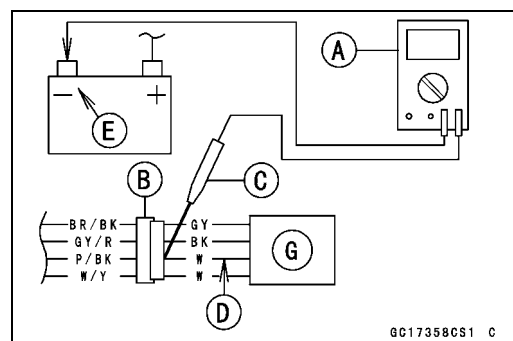
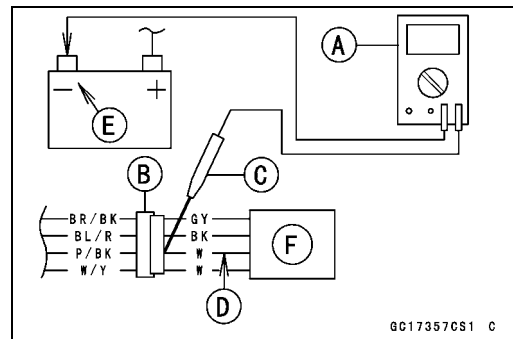
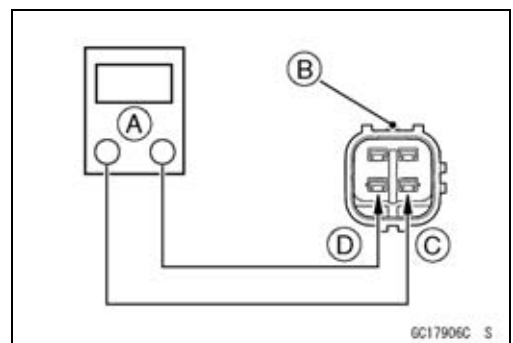



Oxygen Sensor Heaters (#1, #2: Service Code 67)-Equipped Models

- ★ If the reading is incorrect, check the following.
  - Battery (see Charging Condition Inspection in the Electrical System chapter)
  - Main Fuse 30 A (see Fuse Inspection in the Electrical System chapter)
  - Oxygen Sensor Heater Fuse 10 A (see Fuse Inspection in the Electrical System chapter)
- ★ If the reading is good, the power source voltage is normal, inspect the Green lead between the oxygen sensor connector and the ECU for continuity, using the following diagram.
- ★ If the wiring is good, inspect the ECU for its ground, and power supply (see ECU Power Supply Inspection). If the ground and power supply are good, replace the ECU (see ECU section).
- Remove the needle adapter set, and apply silicone sealant to the connector for water proofing.

Sealant - Kawasaki Bond (Silicone Sealant): 56019-120

Oxygen Sensor Circuit

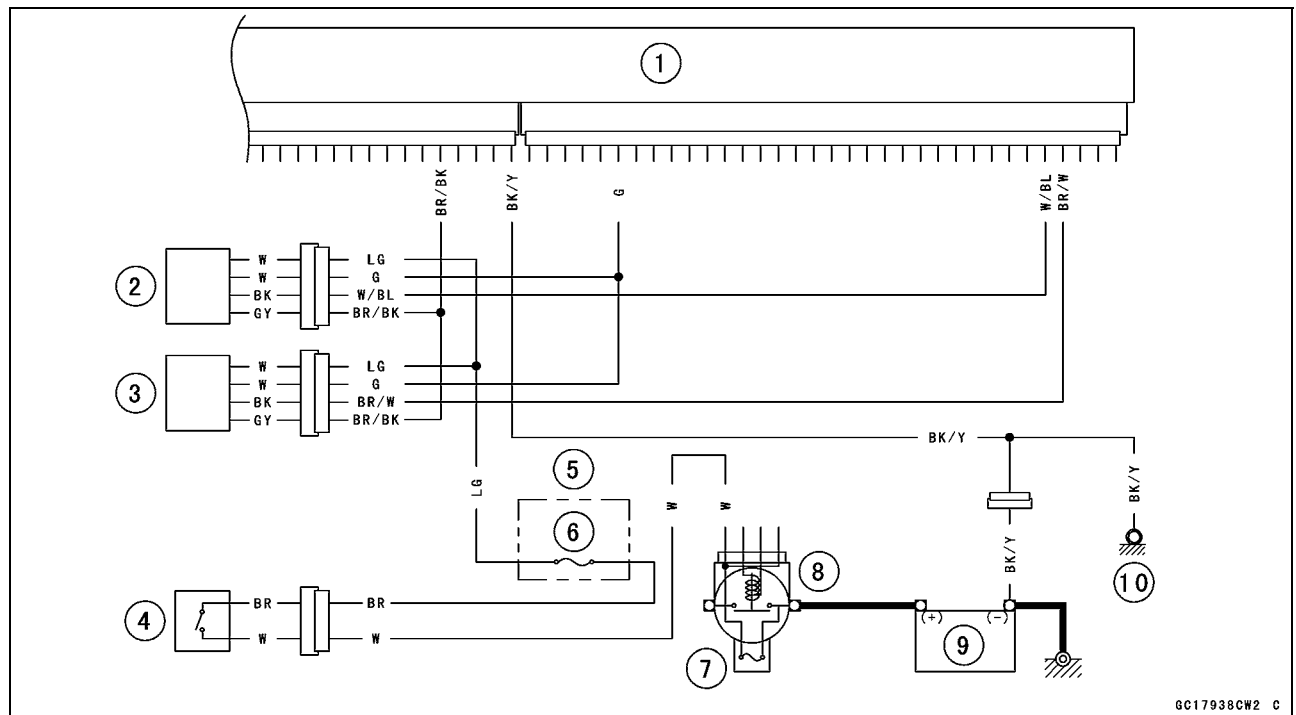

1. ECU
2. Oxygen Sensor #1
3. Oxygen Sensor #2
4. Ignition Switch
5. Fuse Box
6. Oxygen Sensor Fuse 10 A
7. Main Fuse 30 A
8. Starter Relay
9. Battery
10. Frame Ground

## 3-96 FUEL SYSTEM (DFI)

### Oxygen Sensors-Incorrect Output Voltage (#1, #2: Service Code 94, 95)-Equipped Models

Oxygen Sensor #1: Service Code 94  
Oxygen Sensor #2: Service Code 95

#### Oxygen Sensor Removal/Installation

- Refer to Oxygen Sensor Removal and Installation in the Electrical System chapter.

#### Oxygen Sensor Inspection

##### NOTE

- The oxygen sensor itself is the same for #1 [A] and #2 [B], but wiring of the main harness side is different.

- Warm up the engine thoroughly.
- Turn the ignition switch OFF.
- Remove the right side cover (see Right Side Cover Removal in the Frame chapter).
- Connect a digital voltmeter [A] to the each oxygen sensor connector [B] (sensor side), using the needle adapter set.

**Special Tool - Needle Adapter Set: 57001-1457**

#### Oxygen Sensor Output Voltage

##### Connections to Oxygen Sensor Connector

Meter (+) → BK lead

Meter (-) → GY lead

- Remove the air switching valve hoses [A] (both sides) from the fittings.

- Install the suitable plugs [A] (both sides) on the fittings and shut off the secondary air.
- Turn the ignition switch ON.
- Start the engine, and let it idle.
- Measure the output voltage of the sensor with the connector joined.

#### Oxygen Sensor Output Voltage (with Plugs)

Standard: 0.45 ~ 2.5 V

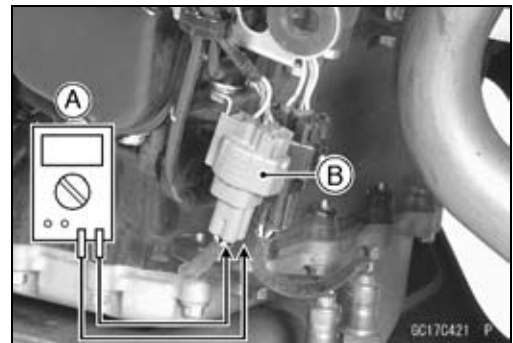
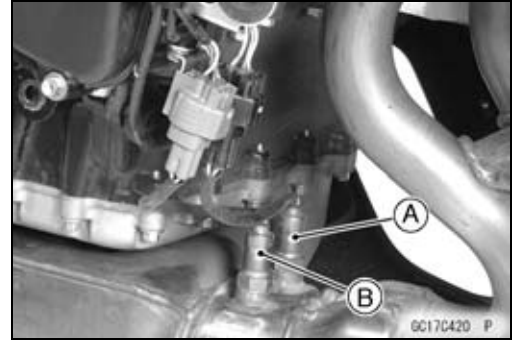

**Oxygen Sensors-Incorrect Output Voltage (#1, #2: Service Code 94, 95)-Equipped Models**

- Next, remove the plugs [A] (both sides) from the fittings with idling.
- Measure the output voltage of the sensor with the connector joined.



**Oxygen Sensor Output Voltage (without Plugs)**

**Standard: 0.05 ~ 0.45 V**

- ★ If the reading is within range (with plugs: 0.45 ~ 2.5 V, without plugs: 0.05 ~ 0.45 V), the oxygen sensor is good.
- ★ If the reading is without range, inspect the engine and fuel supply system.
- ★ If the engine and fuel supply system good, replace the oxygen sensor.
- Remove the needle adapter set, and apply silicone sealant to the seals of the connector for waterproofing.

**Sealant - Kawasaki Bond (Silicone Sealant): 56019-120**

**Oxygen Sensor Circuit**

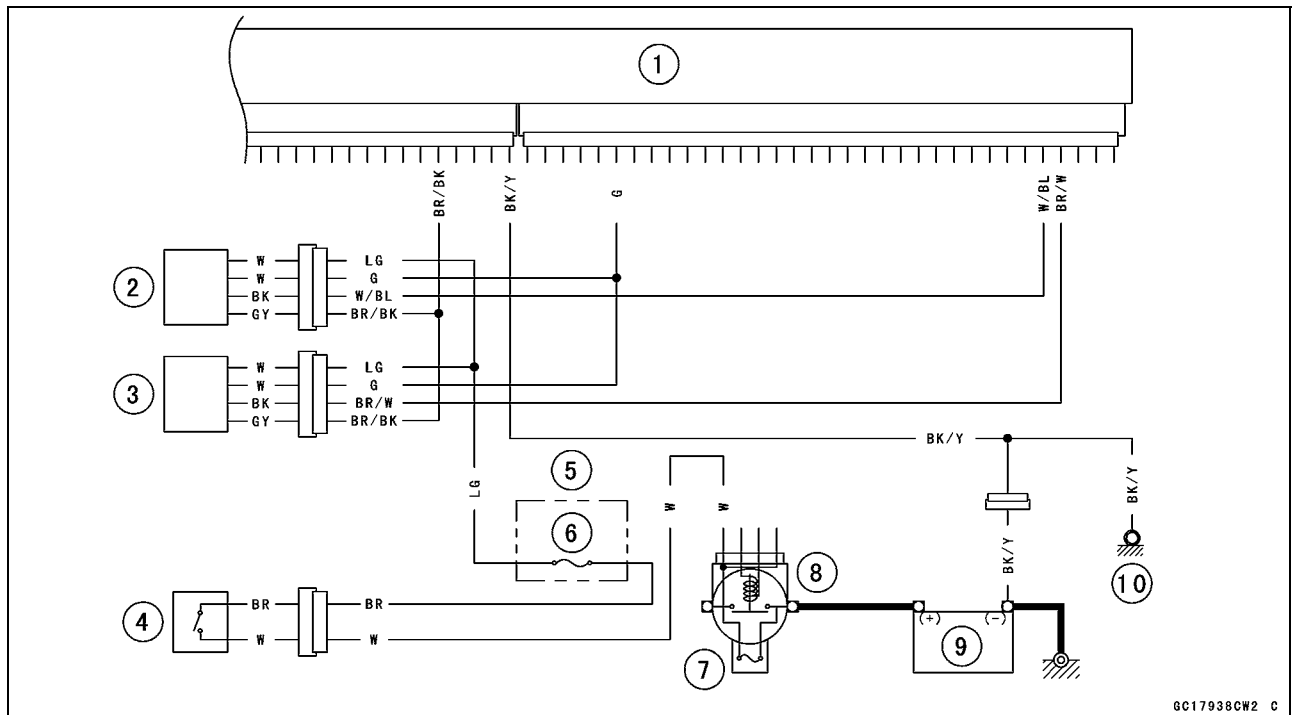

1. ECU
2. Oxygen Sensor #1
3. Oxygen Sensor #2
4. Ignition Switch
5. Fuse Box
6. Oxygen Sensor Fuse 10 A
7. Main Fuse 30 A
8. Starter Relay
9. Battery
10. Frame Ground

## 3-98 FUEL SYSTEM (DFI)

### ECU

#### CAUTION

Never drop the ECU, especially on a hard surface. Such a shock to the ECU can damage it.

#### ECU Identification

○ Most countries have their own regulations, so each ECU has different characteristics. So, do not confuse ECU with each other and use only the ECU for your model. Otherwise, the motorcycle cannot clear the regulation.

#### ECU Identification

Part Number [A]	Specification
21175-0111	U.S.A., without Immobilizer
	U.S.A. (California), without Immobilizer
	Canada, without Immobilizer
21175-0109	Other than U.S.A., U.S.A. (California), Canada, Malaysia and Australia with Immobilizer
21175-0114	Malaysia, with Immobilizer
21175-0113	Australia, with Immobilizer

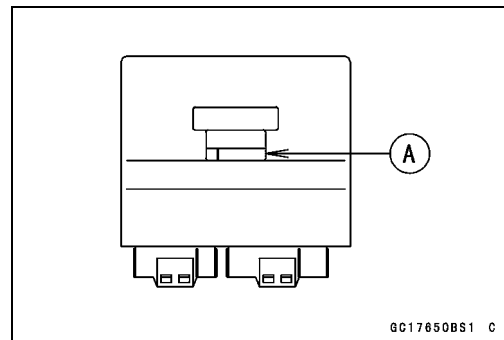

#### ECU Removal

- Remove:
  - Muffler Body
  - Seat Cover (see Muffler Body Removal in the Engine Top End chapter)
  - Battery (see Battery Removal in the Electrical System chapter)
  - Rear Fender [A] (see Flap and Rear Fender Removal in the Frame chapter)
- Pull out ECU [B] with rubber protector.
- Remove:
  - ECU Lead Connectors [A]
  - Rubber Protector [B]
  - ECU [C]

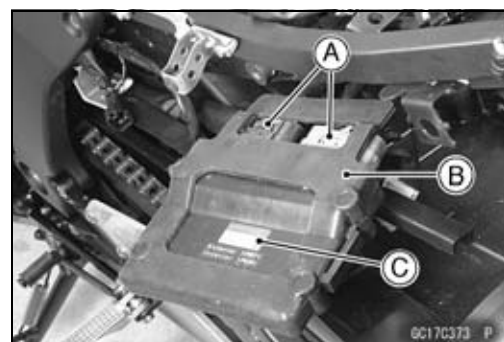

ECU

**ECU Installation**

- Install:
  - ECU [A] (In rubber protector [B])
  - ECU Lead Connectors [C]

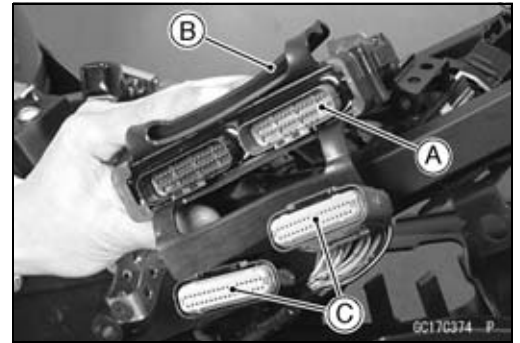

- Insert the slots [A] of the protector onto the brackets [B].

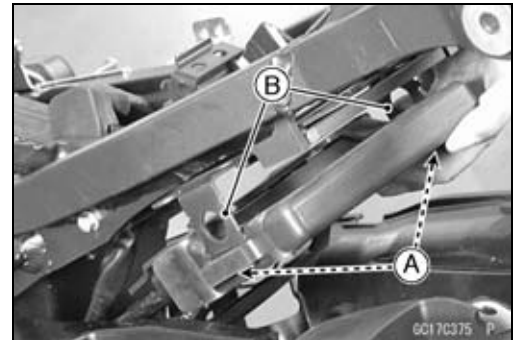

**ECU Power Supply Inspection**

- Visually inspect the terminals [A] of the ECU connectors.
- ★ If the connector is clogged with mud or dust, blow it off with compressed air.
- ★ Replace the main harness if the terminals of the main harness connectors are cracked, bent, or otherwise damaged.
- ★ Replace the ECU if the terminals of the ECU connectors are cracked, bent, or otherwise damaged.

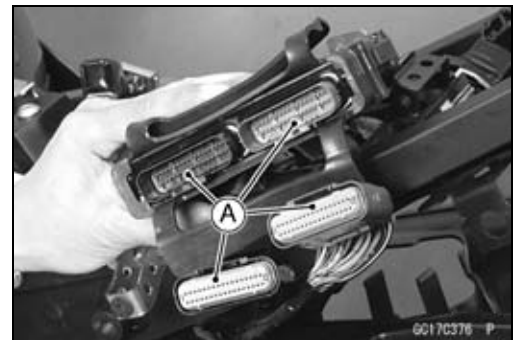

- With the ECU connectors connected, check the following ground lead for continuity with the ignition switch OFF, using a tester and needle adapter set.

**Special Tool - Needle Adapter Set: 57001-1457**

**ECU Grounding Inspection**

- 34, 66, or 67 Terminal (BK/Y) ↔ Battery (-) Terminal: 0 Ω
- Engine Ground ↔ Battery (-) Terminal: 0 Ω

- ★ If no continuity, check the connector, the engine ground lead, or main harness, and repair or replace them if necessary.

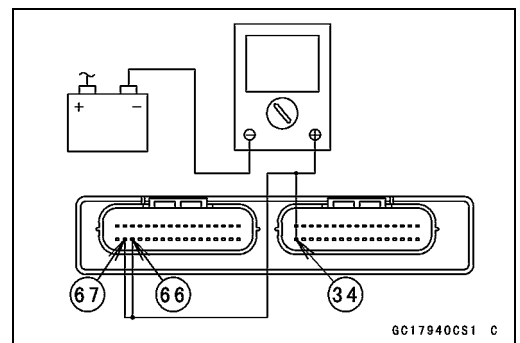

# 3-100 FUEL SYSTEM (DFI)

## ECU

- Check the ECU power source voltage with a tester [A].
- Position the terminal in accordance with terminal numbers of ECU connectors in this chapter figure.  
Battery [B]

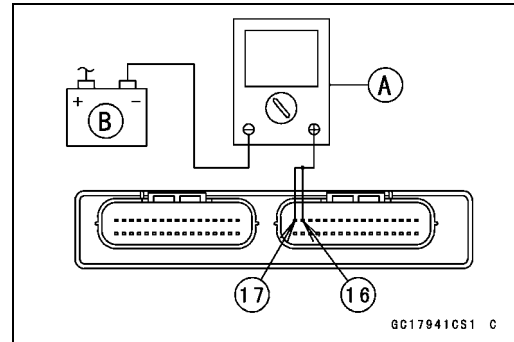

GC17941CS1 C

### ECU Power Source Inspection

#### Tester Connections:

- between 16 (W/Y) Terminal and Battery (-) Terminal
- between 17 (W/BK) Terminal and Battery (-) Terminal

#### Ignition Switch OFF:

- 16 (W/Y) Terminal 0 V,
- 17 (W/BK) Terminal Battery Voltage (12.8 V or more)

#### Ignition Switch ON:

- Battery Voltage (12.8 V or more)

- ★ If the tester does not read as specified, check the following:

- Power Source Wiring (see wiring diagram below)
- Main Fuse 30 A (see Fuse Inspection in the Electrical System chapter)
- ECU Fuse 10 A (see Fuse Inspection in Electrical System chapter)
- ECU Main Relay (see Relay Circuit Inspection in Electrical System chapter)

### ECU Power Source Circuit

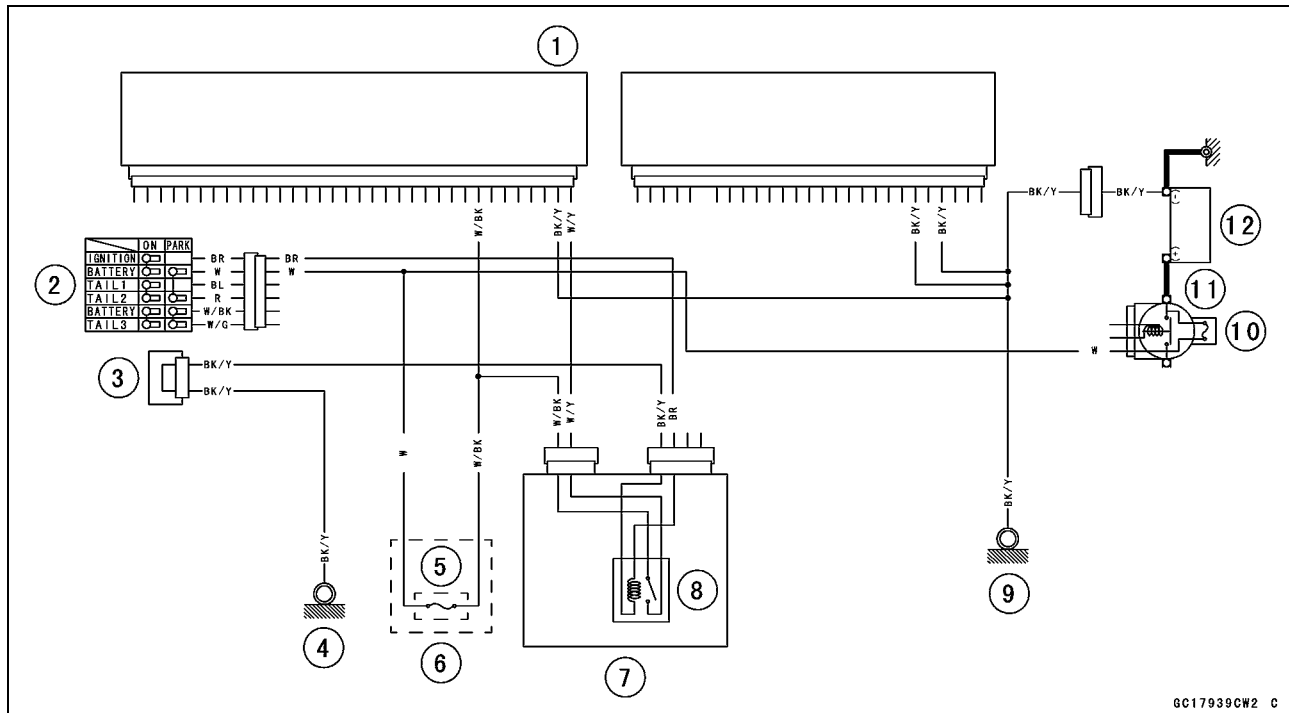

GC17939CW2 C

1. ECU
2. Ignition Switch
3. Joint Connector C
4. Cylinder Head Cover Ground
5. ECU Fuse 10 A
6. Fuse Box
7. Relay Box
8. ECU Main Relay
9. Frame Ground
10. Main Fuse 30 A
11. Starter Relay
12. Battery, 12 V 8 Ah

### DFI Power Source

---

#### ***ECU Fuse Removal***

- Refer to the Electrical System chapter for the 10 A ECU Fuse Removal.

#### ***ECU Fuse Installation***

- ★ If a fuse fails during operation, inspect the DFI system to determine the cause, and then replace it with a new fuse of proper amperage.
- Refer to the Electrical System chapter for the Fuse Installation.

#### ***ECU Fuse Inspection***

- Refer to the Electrical System chapter for the Fuse Inspection.

## 3-102 FUEL SYSTEM (DFI)

### Warning Indicator Light (LED)

#### Warning Indicator Light (LED) Inspection

- The warning indicator light (LED) [A] is used for the FI indicator, immobilizer indicator (immobilizer models) and oil pressure warning indicator.
- In this model, the warning indicator light (LED) (FI/immobilizer) blink by the data sent from the ECU.
- Refer to the Meter Unit (Electrical Combination) Inspection in the Electrical System chapter for the warning indicator light (LED) (FI/immobilizer) inspection.

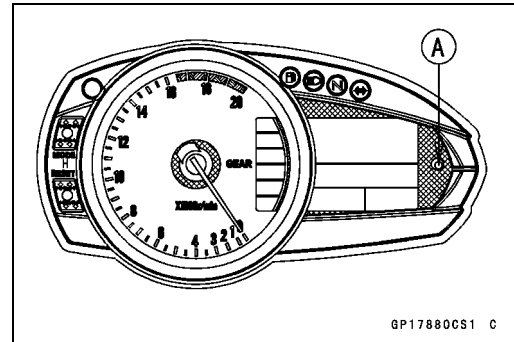

#### Warning Indicator Light (LED) (FI/Immobilizer) Circuit

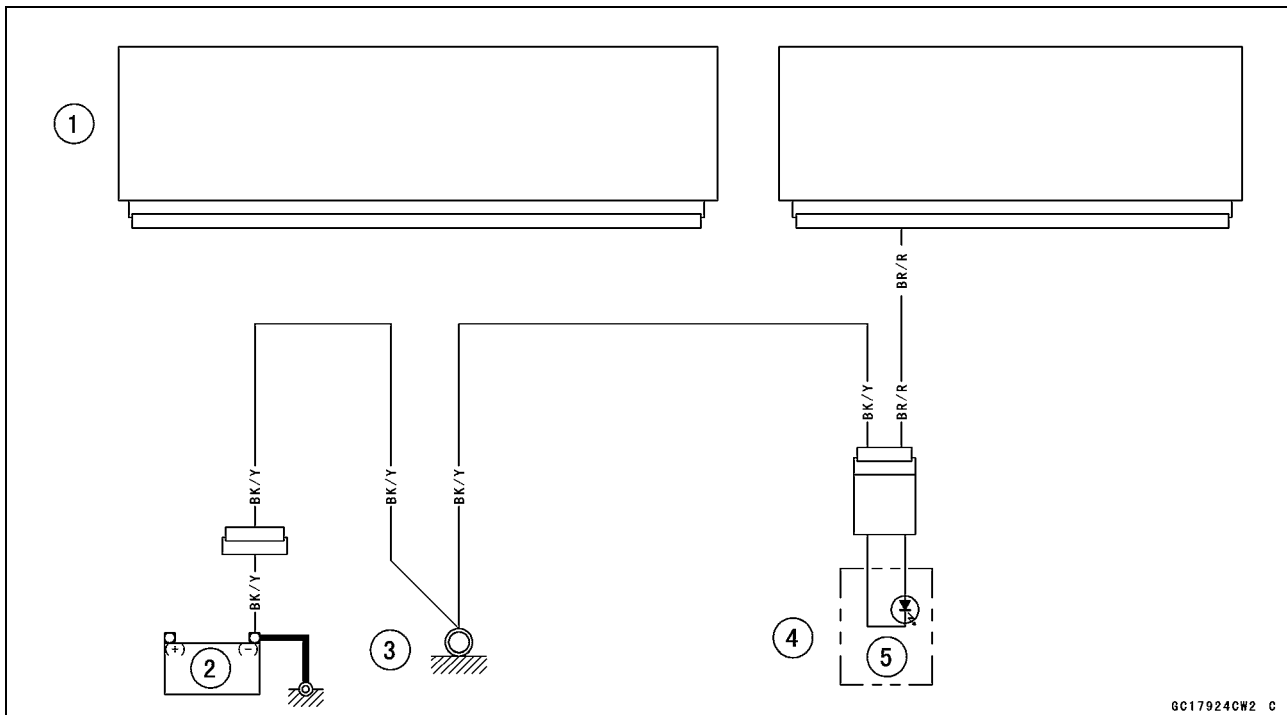

1. ECU
2. Battery 12 V 8 Ah
3. Frame Ground
4. Meter Unit
5. Warning Indicator Light (LED)



Fuel Line

**Fuel Pressure Inspection**

**NOTE**

○ Be sure the battery is fully charged.

- Remove:
  - Front Seat (see Front Seat Removal in the Frame chapter)
- Set up the fuel tank (see Air Cleaner Housing Removal).
- Be sure to place a piece of cloth around the fuel supply pipe of the throttle body assembly and fuel pump.
- Remove the fuel hose (see Fuel Tank Removal).

**⚠ WARNING**

**Be prepared for fuel spillage; any spilled fuel must be completely wiped up immediately. When the fuel hose is disconnected, fuel spills out from the hose and the pipe because of residual pressure. Cover the hose connection with a piece of clean cloth to prevent fuel spillage.**

- Install the fuel pressure gauge adapter [A] and fuel hoses [B] between the fuel supply pipes of the fuel pump and throttle body assy.
- Connect the pressure gauge [C] to the fuel pressure gauge adapter.

**Special Tools - Oil Pressure Gauge, 5 kgf/cm<sup>2</sup>: 57001-125  
 Fuel Pressure Gauge Adapter: 57001-1593  
 Fuel Hose: 57001-1607**

**⚠ WARNING**

**Do not try to start the engine with the fuel hoses disconnected.**

- Turn the ignition switch ON. The fuel pump will turn for 3 seconds, and then stop.

**NOTE**

○ Turn the ignition switch ON and inspect the fuel line leakage after installing the special tools.

**CAUTION**

**Do not drive the fuel pump 3 seconds or more without the fuel in the fuel tank. If the fuel pump is driven without the fuel, it may be damaged.**

- Start the engine, and let it idle.
- Measure the fuel pressure with the engine idling.

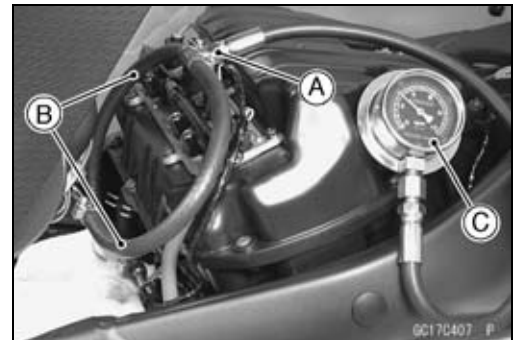

## 3-104 FUEL SYSTEM (DFI)

### Fuel Line

---

#### Fuel Pressure (Idling)

Standard: 294 kPa (3.0 kgf/cm<sup>2</sup>, 43 psi)

#### NOTE

○ *The gauge hand will fluctuate. Read the pressure at the average of the maximum and minimum indications.*

- ★ If the fuel pressure is much higher than the specified, the fuel pressure regulator in the fuel pump have been clogged or stuck. Replace the fuel pump (see Fuel Pump section).
- ★ If the fuel pressure is much lower than specified, check the following.
  - Fuel Line Leakage (see Fuel Injector Fuel Line Inspection)
  - Amount of Fuel Flow (see Fuel Flow Rate Inspection)
- After above checks, measure the fuel pressure again.
- Remove the fuel pressure gauge, hoses and adapter.
- Install:
  - Fuel Hose (see Fuel Hose Replacement in the Periodic Maintenance chapter)
  - Fuel Tank (see Fuel Tank Installation)
- Start the engine and check for fuel leakage.

#### Fuel Flow Rate Inspection

#### NOTE

○ *Be sure the battery is fully charged.*

#### WARNING

**Gasoline is extremely flammable and can be explosive under certain conditions. Make sure the area is well-ventilated and free from any source of flame or sparks; this includes any appliance with a pilot light. Do not smoke. Turn the ignition switch OFF. Be prepared for fuel spillage; any spilled fuel must be completely wiped up immediately.**

- Turn the ignition switch, and engine stop switch OFF.
- Wait until the engine cools down.
- Prepare a measuring cylinder.
- Remove:
  - Front Seat (see Front Seat Removal in the Frame chapter)
  - Fuel Tank Bolts (see Fuel Tank Removal)

## Fuel Line

- Open the fuel tank cap [A] to lower the pressure in the tank.
- Be sure to place a piece of cloth around the fuel supply pipe of the fuel pump.
- Remove the fuel hose from the fuel supply pipe of the fuel pump (see Fuel Tank Removal).

### **⚠ WARNING**

**Be prepared for fuel spillage; any spilled fuel must be completely wiped up immediately. When the fuel hose is disconnected, fuel spills out from the hose and the pipe because of residual pressure. Cover the hose connection with a piece of clean cloth to prevent fuel spillage.**

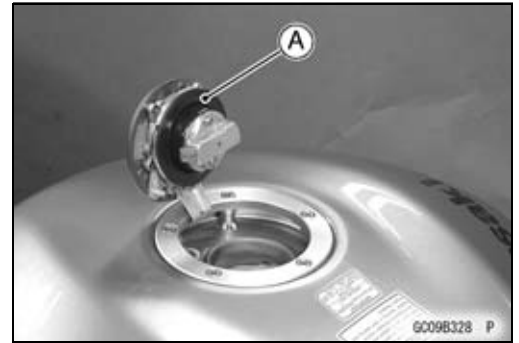

- Connect the fuel hose [A] to the fuel supply pipe of the fuel pump.

**Special Tool - Fuel Hose: 57001-1607**

- Secure the fuel hose with a clamp.
- Insert the fuel hose into the measuring cylinder [B].

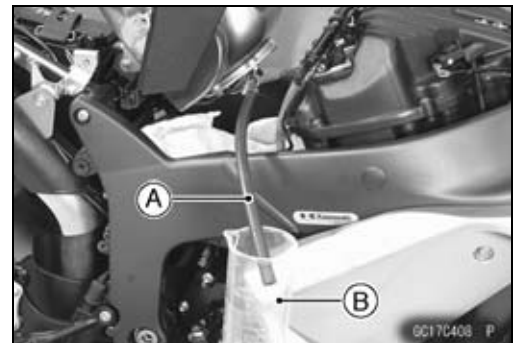

### **⚠ WARNING**

**Wipe off spilled out fuel immediately. Be sure to hold the measuring cylinder vertical.**

- Close the fuel tank cap.
- With the engine stopped, turn the ignition switch ON. The fuel pump should operate for 3 seconds, and then should stop.

### **CAUTION**

**Do not drive the fuel pump 3 seconds or more without the fuel in the fuel tank. If the fuel pump is driven without the fuel, it may be damaged.**

- Measure the discharge for 3 seconds.
- Repeat this operation several times.

#### **Amount of Fuel Flow**

**Standard: 67 mL (2.27 US oz) or more for 3 seconds**

- ★ If the fuel flow is much less than the specified, check the following:

Battery Condition (see Charging Condition Inspection in the Electrical System chapter)

- After inspection, connect the fuel hoses (see Fuel Tank Installation).
- Start the engine and check for fuel leakage.



## Fuel Pump

- Check that the fuel pump terminals [A], fuel reserve switch terminal [B] and band [C] are in place.  
Front [D]
- Apply a non-permanent locking agent to the threads of the fuel pump bolts.
- Tighten the fuel pump bolts to a snug fit following the tightening sequence shown.
- Following the tightening sequence, tighten the fuel pump bolts to the specified torque.

**Torque - Fuel Pump Bolts: 9.8 N·m (1.0 kgf·m, 87 in·lb)**

- Tighten the fuel pump bolts again to check the tightness in the order shown.

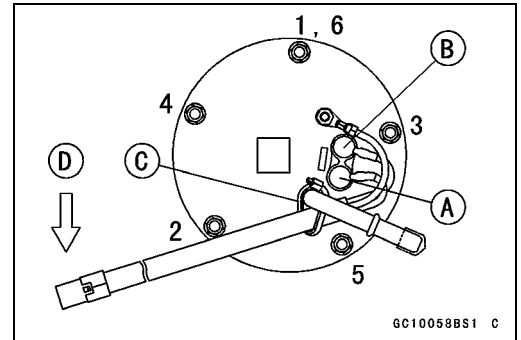

### Fuel Pump Operation Inspection

#### NOTE

○ Be sure the battery is fully charged.

- Turn the ignition switch ON and make sure that the fuel pump operates (make light sounds) for 3 seconds, and then stops.
- Turn the ignition switch OFF.
- ★ If the pump does not work as described above, inspect the operating voltage.

### Fuel Pump Operating Voltage Inspection

#### NOTE

○ Be sure the battery is fully charged.

- Turn the ignition switch OFF.
- Remove:  
Left Side Cover (see Side Cover Removal in the Frame chapter)
- Connect the hand tester (25 V DC) to the connector [A], with needle adapter set.

**Special Tools - Hand Tester: 57001-1394**

**Needle Adapter Set: 57001-1457**

- Measure the operating voltage with the engine stopped, and with the connector joined.
- Turn the ignition switch ON.
- The tester needle should indicate battery voltage for 3 seconds, and then 0 V.

#### Pump Operating Voltage at Pump

##### Connections to Pump Connectors

Tester (+) → Y/R Lead

Tester (-) → BK/W Lead

#### Operating Voltage at Pump Connector

Standard: Battery Voltage (12.8 V) for 3 seconds, and then 0 V



## 3-108 FUEL SYSTEM (DFI)

### Fuel Pump

- ★ If the reading stays on battery voltage, and never shows 0 V. Check the ECU and fuel pump relay.
- ★ If the voltage is in specification, but the pump doesn't work, replace the pump (see Fuel Pump Removal/Installation).
- ★ If there is still no battery voltage, check the pump relay (see Relay Circuit Inspection in the Electrical System chapter).

### Fuel Pump Circuit

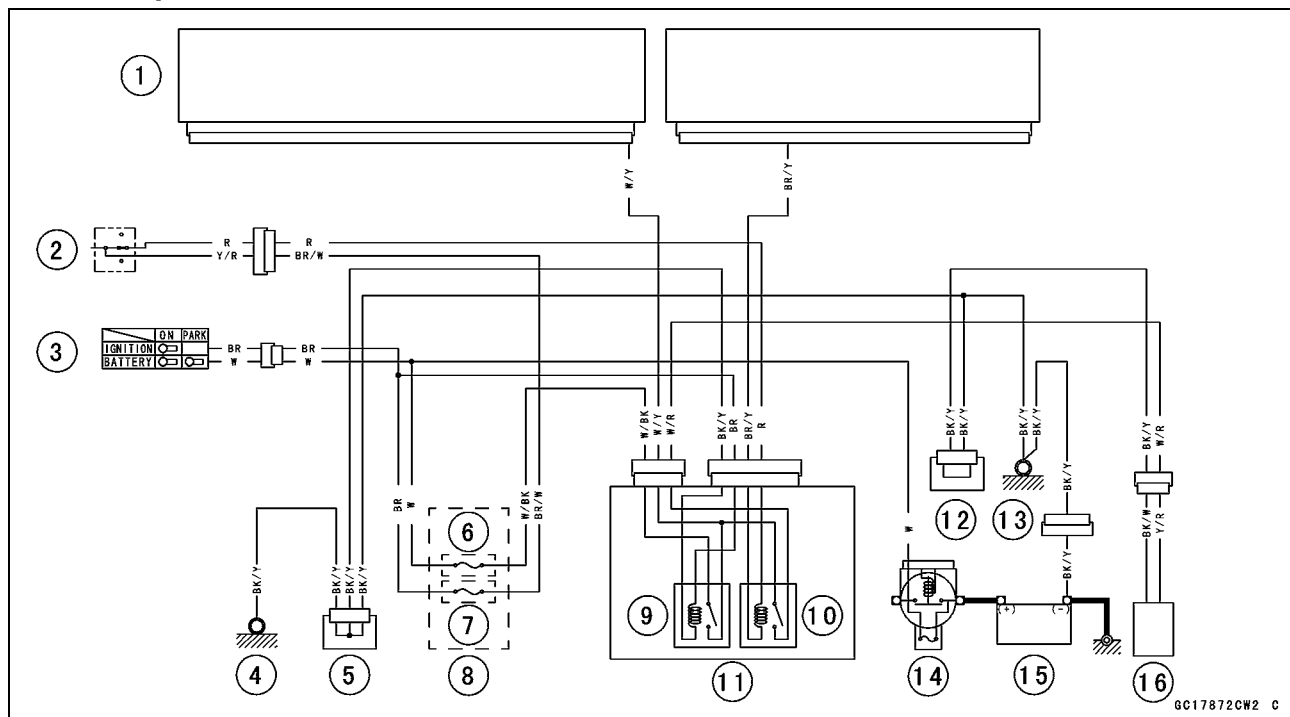

1. ECU
2. Engine Stop Switch
3. Ignition Switch
4. Cylinder Head Cover Ground
5. Joint Connector C
6. ECU Fuse 10 A
7. Ignition Fuse 10 A
8. Fuse Box
9. ECU Main Relay
10. Fuel Pump Relay
11. Relay Box
12. Joint Connector B
13. Frame Ground
14. Main Fuse 30 A
15. Battery 12 V 8 Ah
16. Fuel Pump

## Fuel Pump Relay

### Fuel Pump Relay Removal

#### CAUTION

**Never drop the relay, especially on a hard surface. Such a shock to the relay can damage it.**

- The fuel pump relay is included in the relay box.
- Remove:
  - Right Inner Cover (see Inner Cover Removal in the Frame chapter)
  - Fuse Box [A]
- Disconnect the connectors [B] and remove the relay box [A] from the bracket.

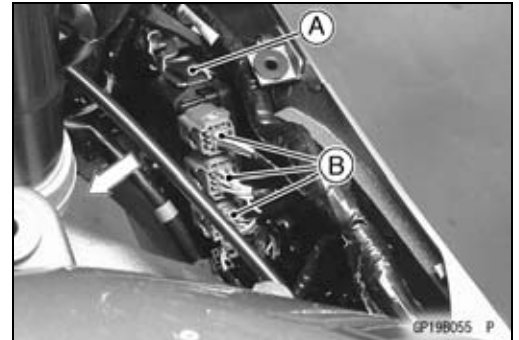

### Fuel Pump Relay Inspection

- Remove the relay box (see Fuel Pump Relay Removal).
- Connect the hand tester [A] and one 12 V battery to the relay connector as shown.

**Special Tool - Hand Tester: 57001-1394**

- Relay Coil Terminals [1] and [2]
- Relay Switch Terminals [3] and [4]

#### Testing Relay

**Tester range: 1  $\Omega$  range**

**Criteria: When battery is connected  $\rightarrow 0 \Omega$**

**When battery is disconnected  $\rightarrow \infty \Omega$**

- ★ If the relay does not work as specified, replace the relay box.

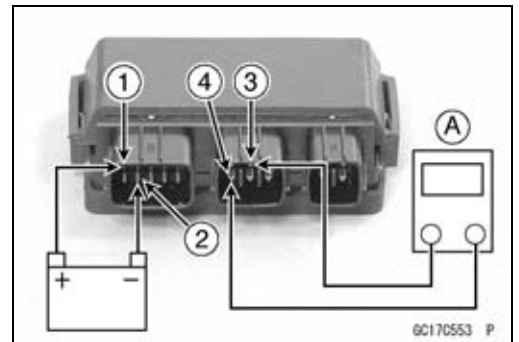

## 3-110 FUEL SYSTEM (DFI)

### Fuel Injectors

#### CAUTION

Never drop the injector, especially on a hard surface. Such a shock to the injector can damage it.

#### Audible Inspection

- Set up the fuel tank (see Air Cleaner Housing Removal).
- Start the engine.
- Apply the tip of a screwdriver [A] to the injector [B]. Put the grip end onto your ear, and listen whether the injector is clicking or not.
- A sound scope can also be used.
- Do the same for the other injector.
- ★ If all the injectors click at a regular intervals, the injectors are good.
- The click interval becomes shorter as the engine speed rises.
- ★ If either injector doesn't click, perform the "Injector Signal Test" for injector operation.

#### NOTE

○ The secondary fuel injectors operating with following conditions.

Engine speed is over 8 000 rpm (r/min)

Throttle opening is over 30°

#### Injector Signal Test

- Prepare two test light sets with terminals as shown.
  - Rating of Bulb [A]: 12 V × 3 ~ 3.4 W
  - Terminal Width [B]: 1.8 mm (0.07 in.)
  - Terminal Thickness [C]: 0.8 mm (0.03 in.)

#### CAUTION

Do not use larger terminals than specified above. A larger terminal could damage the injector main harness connector, leading to harness repair or replacement.

Be sure to connect bulbs in series. The bulb works as a current limiter to protect the solenoid in the injector from excessive current.

- Remove connectors for injector [A].
- Connect each test light set [B] to the injector sub harness connector [C].
- Turn the ignition switch ON.
- While cranking the engine with the starter motor, watch the test lights.
- ★ If the test lights flicker at regular intervals, the injector circuit in the ECU, and the wiring are good. Perform the "Injector Resistance Inspection" in this chapter.

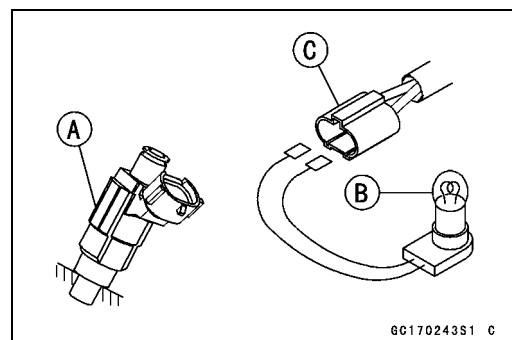
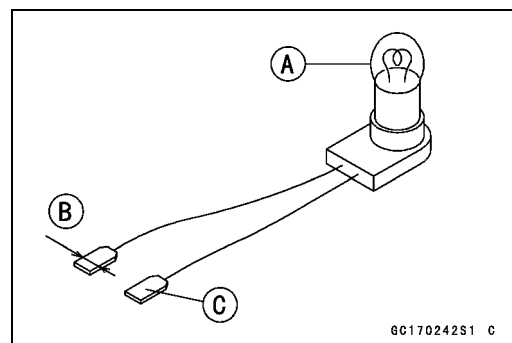
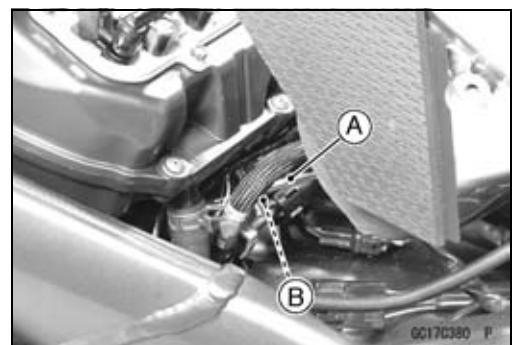
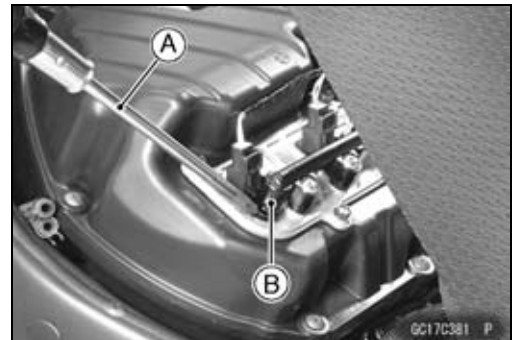



## Fuel Injectors

○Injector signals can be also confirmed by connecting the hand tester (AC 10 V) instead of the test light set to the injector main harness connector. Crank the engine with the starter motor, and check to see if the hand oscillates at regular intervals.

**Special Tool - Hand Tester: 57001-1394**

★If the test light doesn't flicker (or the test hand doesn't oscillates), check the wiring and connectors again. If the wiring is good, check the injector voltage (see Injector Voltage Inspection).

### Injector Resistance Inspection

- Set up the fuel tank (see Air Cleaner Housing Removal).
- Disconnect the connector from the injectors [A].
- For the primary fuel injector #3 [B], remove the hose joint of the nozzle assy (see Nozzle Assy Removal).
- Measure the injector resistance with the hand tester.

**Special Tool - Hand Tester: 57001-1394**

#### Secondary Fuel Injector Resistance Connections to Injectors

Meter (+)		Meter (-)
#1: W/R	↔	O/R Terminal
#2: W/R	↔	O/G Terminal
#3: W/R	↔	O/BK Terminal
#4: W/R	↔	O/Y Terminal

**Standard: About 10.5 Ω at 20°C (68°F)**

#### Primary Injector Resistance Connections to Injector

Meter (+)		Meter (-)
#1: W/R	↔	BL/R Terminal
#2: W/R	↔	BL/G Terminal
#3: W/R	↔	BL/BK Terminal
#4: W/R	↔	BL/Y Terminal

**Standard: about 11.7 ~ 12.3 Ω @20°C (68°F)**

★If the reading is out of the range, perform the "Injector Unit Test" in this chapter.

★If the reading is normal, perform the "Injector Unit Test" for confirmation.

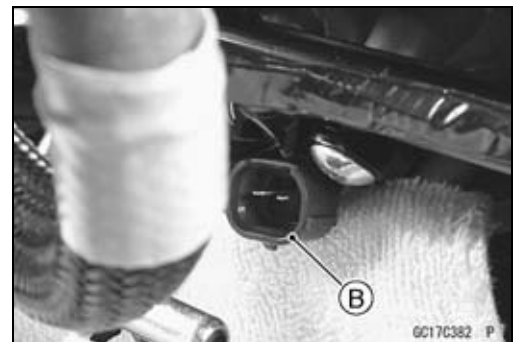
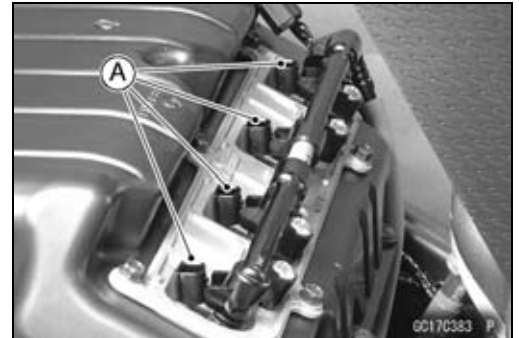

## 3-112 FUEL SYSTEM (DFI)

### Fuel Injectors

#### Injector Unit Test

- Use two leads [A] and the same test light set [B] as in "Injector Signal Test".  
Rating of Bulb [C]: 12 V × (3 ~ 3.4) W  
12 V Battery [D]

#### CAUTION

**Be sure to connect the bulb in series. The bulb works as a current limiter to protect the solenoid in the injector from excessive current.**

- Connect the test light set to the injector [E] as shown.
- Open and connect [F] the end of the lead to the battery (-) terminal repeatedly. The injector should click.
- ★ If the injector does not click, replace the injector.
- ★ If the injector clicks, check the wiring again. If the wiring is good, replace the ECU.

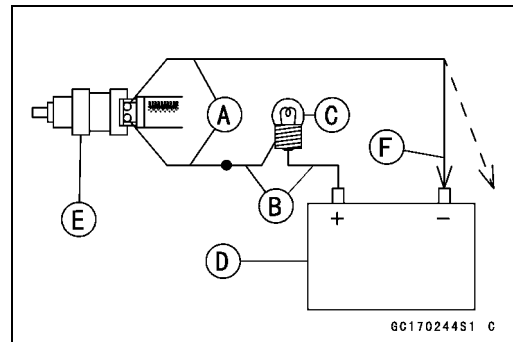

#### Injector Voltage Inspection

##### NOTE

○ Be sure the battery is fully charged.

- Turn the ignition switch OFF.
- Set up the fuel tank (see Air Cleaner Housing Removal)
- Connect a digital voltmeter [A] to the connector [B], with the needle adapter set.

**Special Tool - Needle Adapter Set: 57001-1457**

##### Secondary Fuel Injector Power Source Voltage

Connector to Injector #1, #2, #3, #4

Meter (+) → W/R lead

Meter (-) → Battery (-) Terminal

##### Primary Fuel Injector Power Source Voltage

Connector to Injector #1, #2, #3, #4

Meter (+) → W/R lead

Meter (-) → Battery (-) Terminal

- Install the fuel tank (see Fuel Tank Installation).
- Turn the ignition switch ON.

##### Power Source Voltage at Injector Connector

Standard: Battery Voltage (12.8 V or more)

- ★ If the power source voltage is less than standard, check the wiring (see wiring diagram), fuel pump relay (see Fuel Pump Relay Inspection) and ECU power source (see ECU Power Supply Inspection).

- Turn the ignition switch OFF.
- Set up the fuel tank (see Air Cleaner Housing Removal)
- Connect a digital voltmeter [A] to the connector [B], with the needle adapter set [C].

**Special Tool - Needle Adapter Set: 57001-1457**

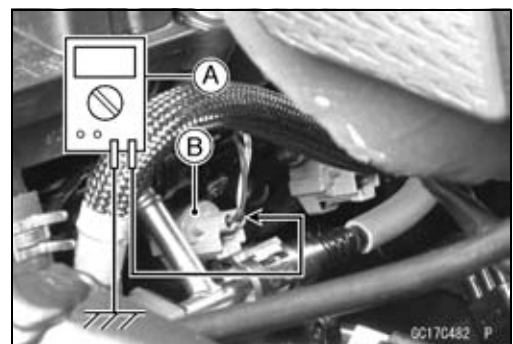
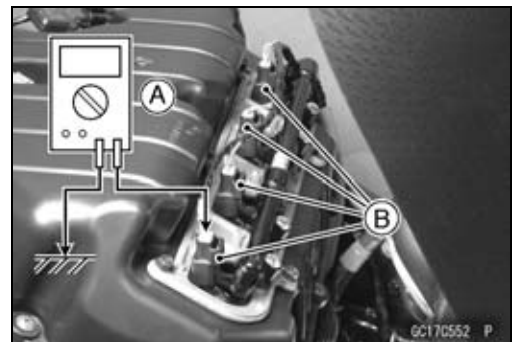

## Fuel Injectors

### Secondary Fuel Injector Output Voltage

#### Connections to Injector #1

Meter (+) → O/R lead

Meter (-) → Battery (-) Terminal

#### Connections to Injector #2

Meter (+) → O/G lead

Meter (-) → Battery (-) Terminal

#### Connections to Injector #3

Meter (+) → O/BK lead

Meter (-) → Battery (-) Terminal

#### Connections to Injector #4

Meter (+) → O/Y lead

Meter (-) → Battery (-) Terminal

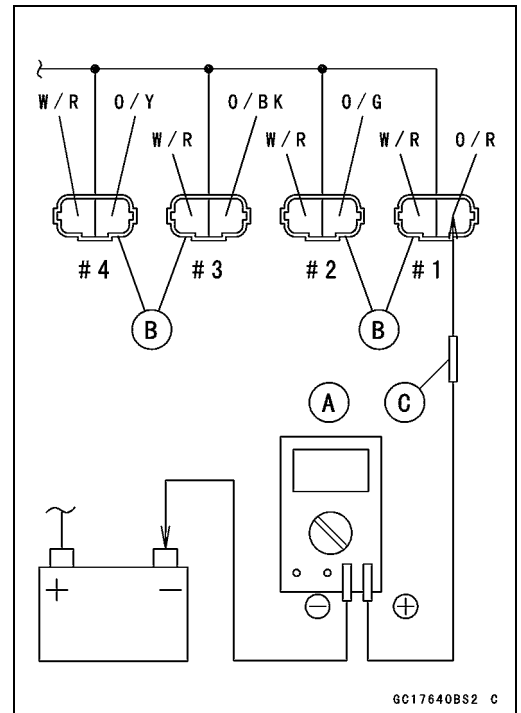

### Primary Fuel Injector Output Voltage

#### Connections to Injector #1

Meter (+) → BL/R lead

Meter (-) → Battery (-) Terminal

#### Connections to Injector #2

Meter (+) → BL/G lead

Meter (-) → Battery (-) Terminal

#### Connections to Injector #3

Meter (+) → BL/BK lead

Meter (-) → Battery (-) Terminal

#### Connections to Injector #4

Meter (+) → BL/Y lead

Meter (-) → Battery (-) Terminal

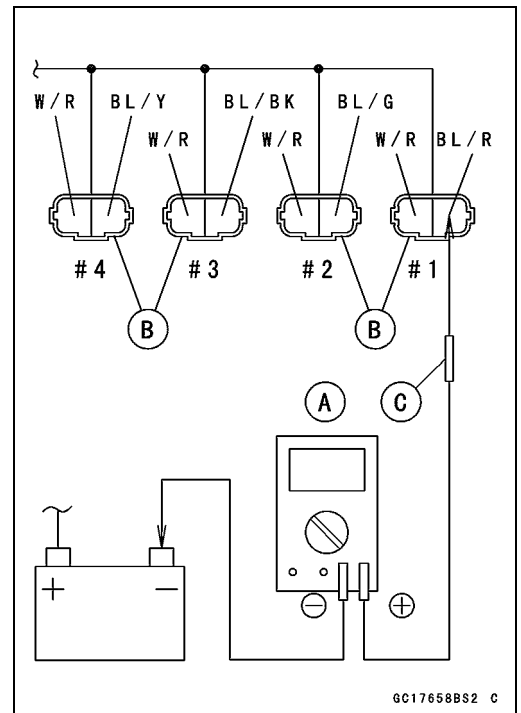

- Install the fuel tank (see Fuel Tank Installation).
- Turn the ignition switch ON.

### Output Voltage at Injector Connector

Standard: Battery Voltage (12.8 V or more)

### NOTE

○ The secondary fuel injectors operating with following conditions.

Engine speeds is over 8 000 rpm (r/min)

Throttle opening is over 30°

- ★ If the output voltage is out of the standard, replace the ECU (see ECU Removal/Installation).

## 3-114 FUEL SYSTEM (DFI)

### Fuel Injectors

#### **Injector Fuel Line Inspection**

- Remove the nozzle assy (see Nozzle Assy Removal).
- Remove the throttle body assy (see Throttle Body Assy).
- Check the injector fuel line for leakage as follows:
  - Connect a commercially available vacuum/pressure pump [A] to the nipple of the delivery pipe [B] with the fuel hose [C] (both ends connected with the clamps [D]) as shown.
  - Apply soap and water solution to the areas [E] as shown.
  - Watching the pressure gauge, squeeze the pump lever [F], and build up the pressure until the pressure reaches the maximum pressure.

#### **Fuel Line Maximum Pressure**

Standard: 300 kPa (3.06 kgf/cm<sup>2</sup>, 43 psi)

#### **CAUTION**

**During pressure testing, do not exceed the maximum pressure for which the system is designed.**

- Watch the gauge for at least 6 seconds.
- ★ If the pressure holds steady, the system is good.
- ★ If the pressure drops at once, or if bubbles are found in the area, the line is leaking. Replace the delivery pipe, injectors and related parts (see appropriate sections).
- Repeat the leak test, and check the fuel line for no leakage.
- Install the throttle body assy (see Throttle Body Assy Installation).
- Install the nozzle assy (see Nozzle Assy Installation).
- Run the hoses correctly (see Cable, Wire, and Hose Routing section in the Appendix chapter).

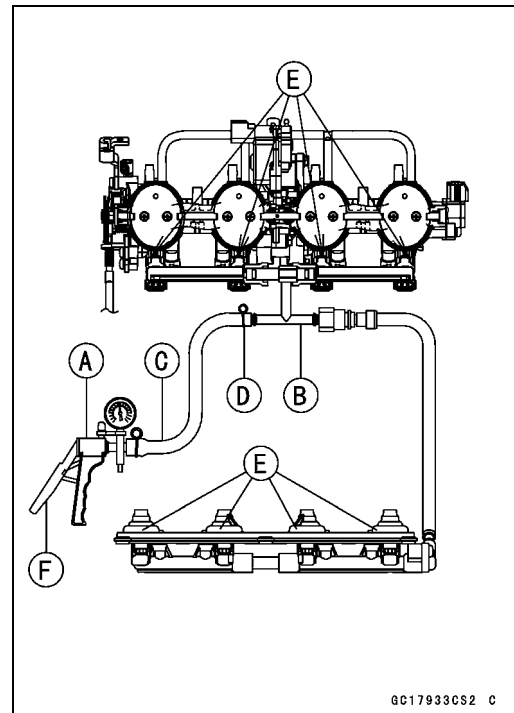

Fuel Injectors

Fuel Injector Circuit

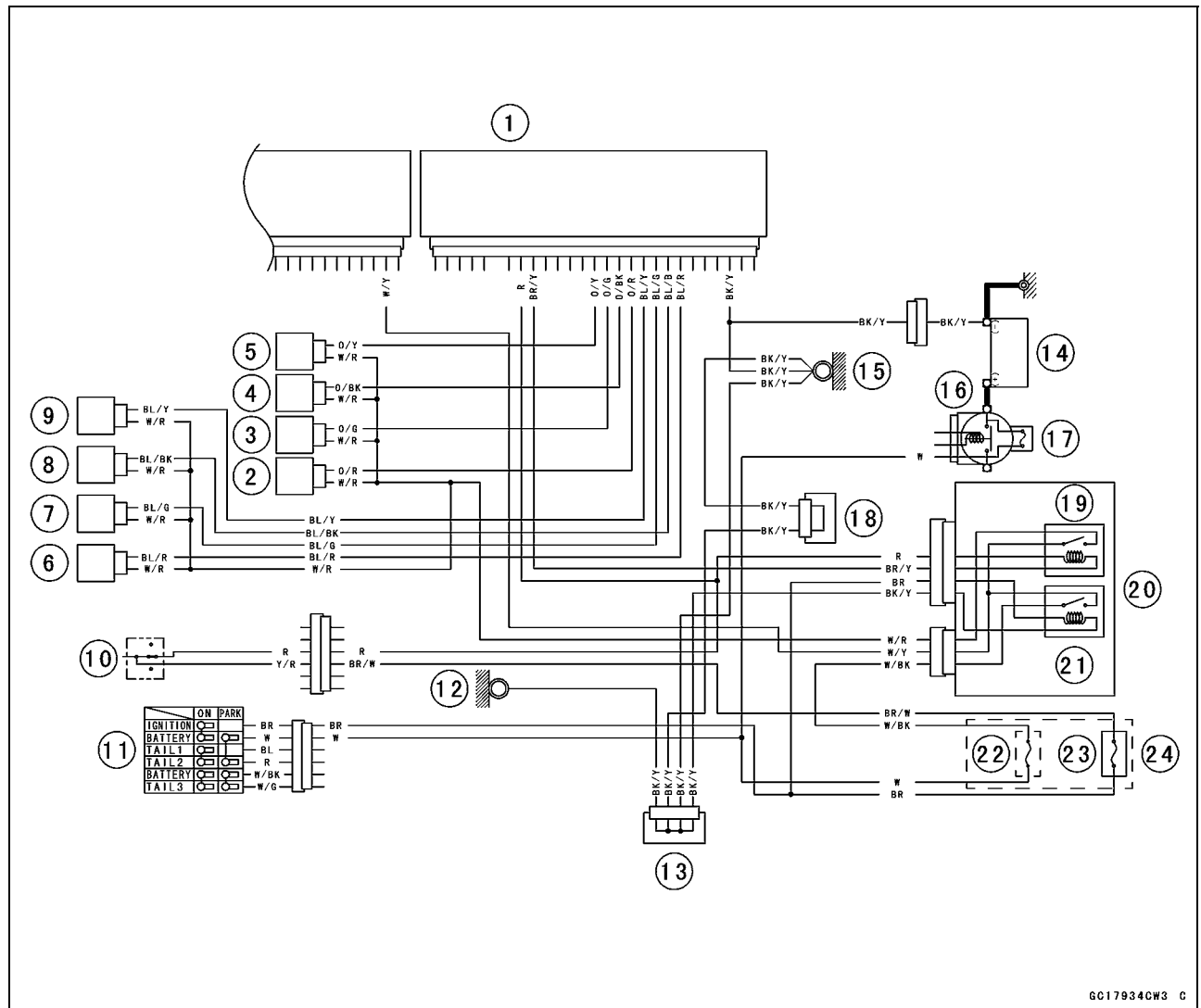

GC17934CW3 C

1. ECU
2. Secondary Fuel Injector #1
3. Secondary Fuel Injector #2
4. Secondary Fuel Injector #3
5. Secondary Fuel Injector #4
6. Primary Fuel Injector #1
7. Primary Fuel Injector #2
8. Primary Fuel Injector #3
9. Primary Fuel Injector #4
10. Engine Stop Switch
11. Ignition Switch
12. Cylinder Head Cover Ground
13. Joint Connector C
14. Battery 12 V 8 Ah
15. Frame Ground
16. Starter Relay
17. Main Fuse 30 A
18. Joint Connector B
19. Fuel Pump Relay
20. Relay Box
21. ECU Main Relay
22. ECU Fuse 10 A
23. Ignition Fuse 10 A
24. Fuse Box

## 3-116 FUEL SYSTEM (DFI)

---

### Throttle Grip and Cables

---

#### ***Free Play Inspection***

- Refer to the Throttle Control System Inspection in the Periodic Maintenance chapter (see Throttle Control System Inspection in the Periodic Maintenance chapter).

#### ***Free Play Adjustment***

- Refer to the Throttle Control System Inspection in the Periodic Maintenance chapter (see Throttle Control System Inspection in the Periodic Maintenance chapter).

#### ***Cable Installation***

- Install the throttle cables in accordance with the Cable, Wire, and Hose Routing section in the Appendix chapter.
- Install the lower ends of the throttle cables in the cable bracket on the throttle body assy after installing the upper ends of the throttle cables in the grip.
- After installation, adjust each cable properly (see Throttle Control System Inspection in the Periodic Maintenance chapter).

#### **⚠ WARNING**

**Operation with incorrectly routed or improperly adjusted cables could result in an unsafe riding condition.**

#### ***Cable Lubrication***

- Refer to the Chassis Parts Lubrication in the Periodic Maintenance chapter (see Chassis Parts Lubrication in the Periodic Maintenance chapter).

## Throttle Body Assy

### Idle Speed Inspection

- Refer to the Idle Speed Inspection in the Periodic Maintenance chapter .

### Synchronization Inspection

- Refer to the Engine Vacuum Synchronization Inspection in the Periodic Maintenance chapter.

### Synchronization Adjustment

- Refer to the Engine Vacuum Synchronization Inspection in the Periodic Maintenance chapter.

### Throttle Body Assy Removal

#### **⚠ WARNING**

**Gasoline is extremely flammable and can be explosive under certain conditions. Turn the ignition switch OFF. Disconnect the battery (–) cable terminal. Do not smoke. Make sure the area is well-ventilated and free from any source of flame or sparks; this includes any appliance with a pilot light.**

**Be prepared for fuel spillage: any spilled fuel must be completely wiped up immediately.**

- Remove:
  - Fuel Tank (see Fuel Tank Removal)
  - Air Cleaner Housing (see Air Cleaner Housing Removal in this chapter)
- Be sure to place a piece of cloth around the fuel supply pipe of the throttle body assy.
- Disconnect:
  - Subthrottle Valve Actuator Connector [A]
  - Subthrottle Sensor Connector [B]
  - Main Throttle Sensor Connector [C]
  - Primary Injector Connectors [D]
  - Water Temperature Sensor Connector [E]
  - Clamp [F]
- Remove:
  - Vacuum Switch Valve Vacuum Hose
  - Vacuum Hose (California Model)
- Loosen:
  - Clamp Bolts [A]

**Special Tool - Carburetor Drain Plug Wrench, Hex: 57001-1269 [B]**
- Insert the wrench from the outside of the frame.
- Remove the throttle body assy from the holder.

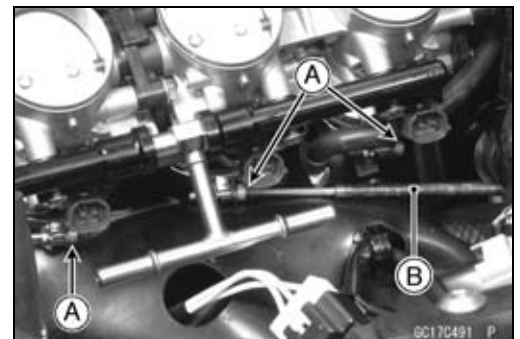
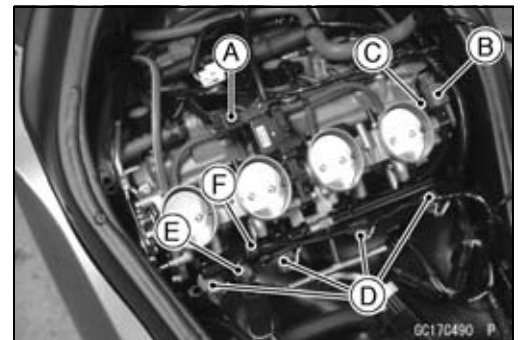

#### **CAUTION**

**When removing the throttle body assy, put the main throttle valves in the throttle bore, be careful not to damage to valves.**

## 3-118 FUEL SYSTEM (DFI)

### Throttle Body Assy

- Remove the throttle case [A] to make a throttle cable slack.



- Remove:
  - Bolt [A]
  - Holding Plate [B]
  - Throttle Cables [C]

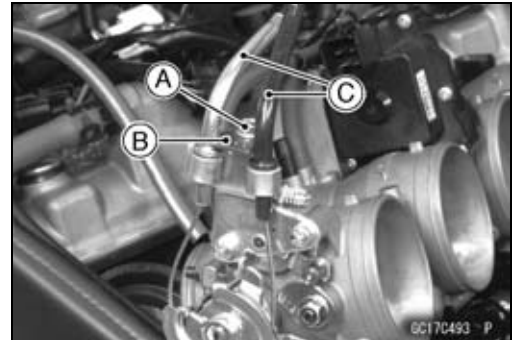

- After removing the throttle body assy, stuff pieces of lint-free, clean cloths into the throttle body holders.

#### CAUTION

If dirt gets into the engine, excessive engine wear and possible engine damage will occur.

#### Throttle Body Assy Installation

- Install the holder clamp bolts in the direction as shown.
  - Heat Insulation Rubber Plate [A]
  - Bolt Heads [B]
- Put the hole [C] of the clamp on the projection [D] of the holder.
- Install the lower ends of the throttle cables in the throttle body assy.
- Apply a non-permanent locking agent.

**Torque - Throttle Cable Holder Plate Bolt: 3.9 N·m (0.40 kgf·m, 35 in·lb)**

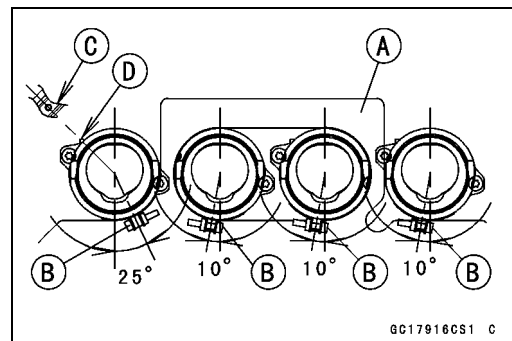

#### CAUTION

When installing the throttle body assy, put the main throttle valves in the throttle bore, be careful not to damage to valves.

- Tighten:
  - Torque - Throttle Body Assembly Holder Clamp Bolts: 3.0 N·m (0.30 kgf·m, 27 in·lb)**
- Install the removed connectors.
- Run the vacuum hoses as shown in the Cable, Wire, and Hose Routing section in the Appendix chapter.
- When installing the fuel hose, refer to Fuel Tank Installation in this chapter.



## Throttle Body Assy

● Adjust:

Throttle Grip Free Play (see Throttle Control System Inspection in the Periodic Maintenance chapter)

Idle Speed (see Idle Speed Adjustment in the Periodic Maintenance chapter)

### Throttle Body Assy Disassembly

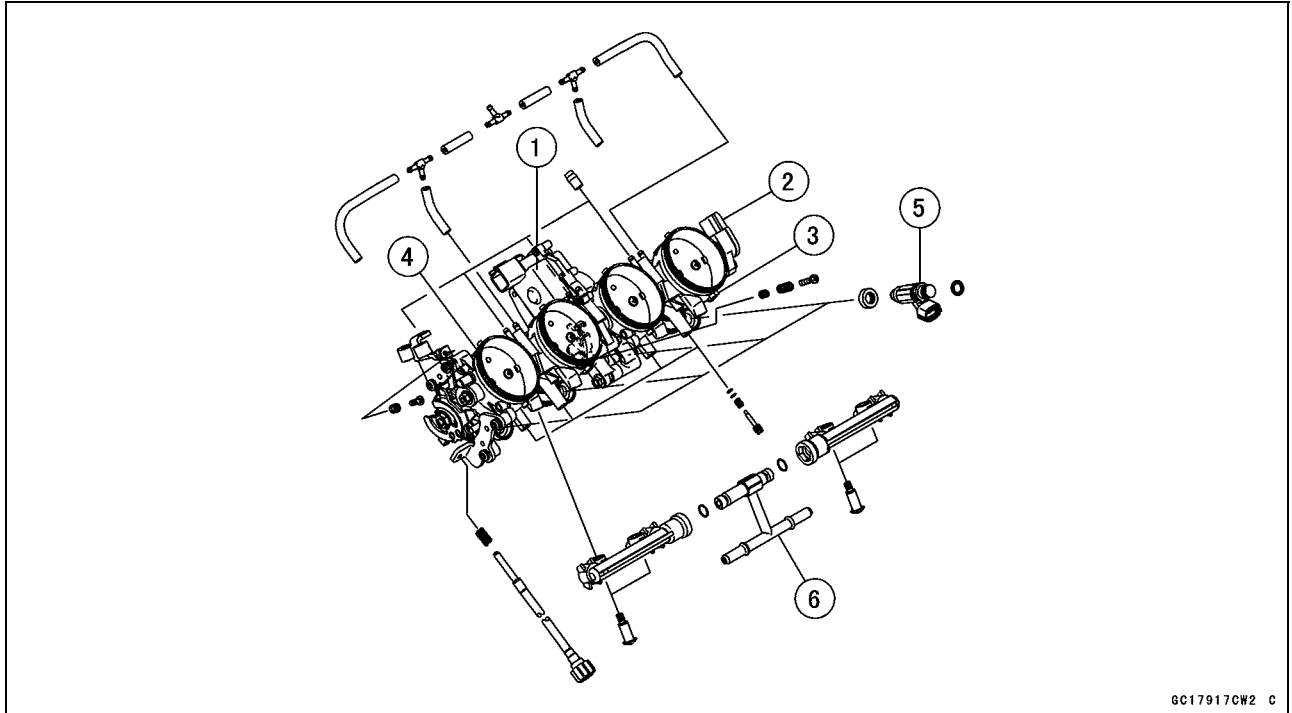

GC17917CW2 C

1. Subthrottle Valve Actuator
2. Subthrottle Sensor
3. Main Throttle Sensor
4. Throttle Body Assy
5. Injector
6. Delivery Pipe Assy

### CAUTION

**Do not remove, disassemble or adjust the main throttle sensor, subthrottle sensor, subthrottle valve actuator, throttle link mechanism and throttle body assy, because they are adjust or set surely at the manufacturer. Adjustment of these parts could result in poor performance, requiring replacement of the throttle body assy.**

- Remove the throttle body assy (see Throttle Body Assy Removal).
- Remove the injector connectors.
- Remove the screws [A] to pull out the injector assys from the throttle body assy together with the delivery pipe [B].

### NOTE

○ Do not damage the part of insert of the injectors when they are pulled out from the throttle body.

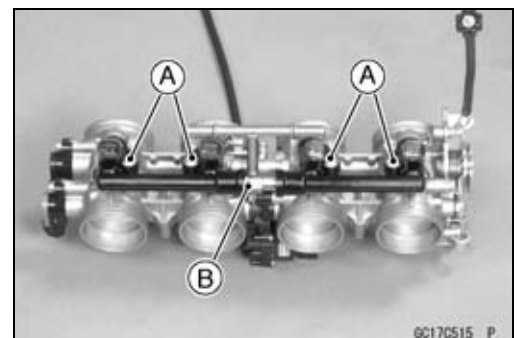

GC17C515 P

## 3-120 FUEL SYSTEM (DFI)

### Throttle Body Assy

- Pull out the injectors [A] from the delivery pipe [B].

#### NOTE

○ Do not damage the part of insert of the injectors when they are pulled out from the delivery pipe.

- Separate the delivery pipes.

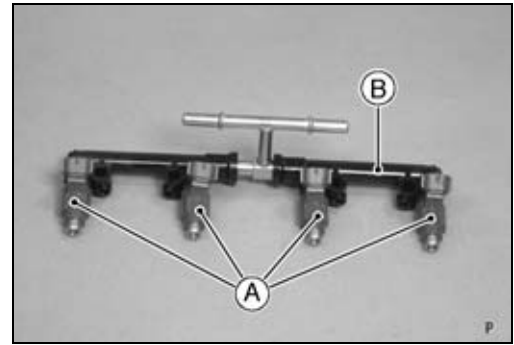

### Throttle Body Assy Assembly

- Before assembling, blow away dirt or dust from the throttle body and delivery pipes by applying compressed air.
- Apply engine oil to the new O-rings [A] of each injector, insert them to the delivery pipe [B] and confirm whether the injectors turn smoothly or not.

#### NOTE

○ Replace the O-ring of injectors and the dust seals of delivery pipe to new one.

- Apply engine oil to the new dust seals [A], insert the injectors installed to the delivery pipe to the throttle body.

#### NOTE

○ Replace the dust seals of the throttle body to new one.

- Install the delivery pipe assy to the throttle body.
- Tighten:  
**Torque - Delivery Pipe Mounting Screws: 3.4 N-m (0.35 kgf-m, 30 in-lb)**

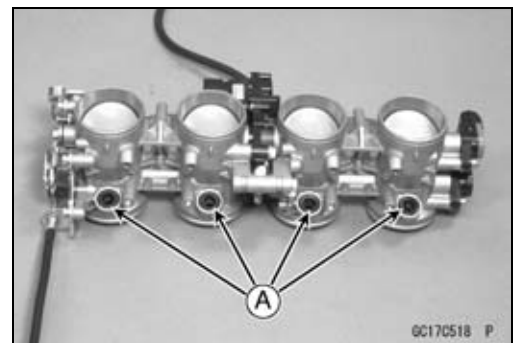
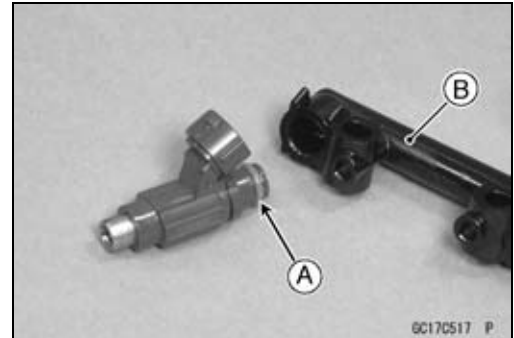

- Insert the each hoses to the throttle body fittings.
- Install the throttle body assy (see Throttle Body Assy Installation).

## Nozzle Assy

### Nozzle Assy Removal

- Set up the fuel tank (see Air Cleaner Housing Removal).
- Be sure to place a piece of cloth [A] around the fuel hose joint [B].
- Push the joint lock claws [C].

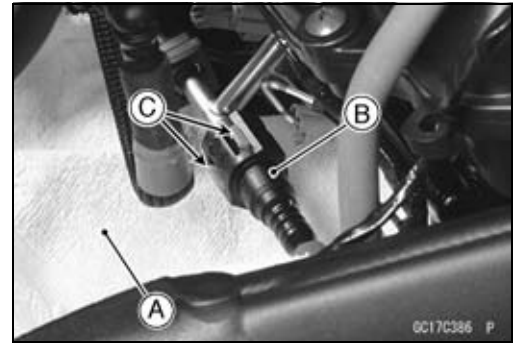

- Pull the joint lock [A] as shown.
- Pull the fuel hose joint [B] out of the delivery pipe [C].

### **⚠ WARNING**

**Be prepared for fuel spillage; any spilled fuel must be completely wiped up immediately. When the fuel hose is disconnected, fuel spills out from the hose and the pipe because of residual pressure. Cover the hose connection with a piece of clean cloth to prevent fuel spillage.**

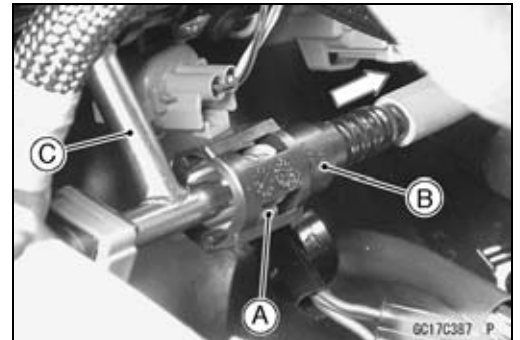

- Remove:
  - Nozzle Assy Lead Connectors [A]
  - Nozzle Assy Mounting Bolts [B]
  - Nozzle Assy [C]

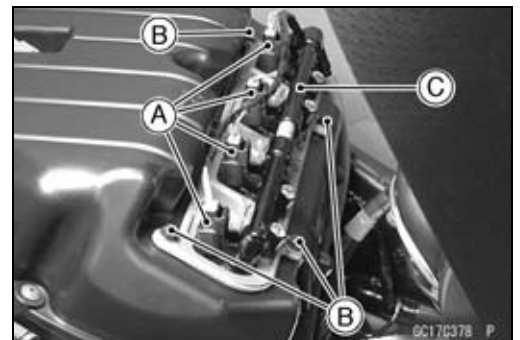

### Nozzle Assy Installation

- Install the nozzle assy and tighten the bolts.
  - Torque - Nozzle Assy Mounting Bolts: 6.9 N·m (0.70 kgf·m, 61 in·lb)**
- Install:
  - Nozzle Assy Lead Connectors
- Insert the fuel hose joint [A] straight onto the delivery pipe until the hose joint clicks.
- Push [B] the joint lock [C] until the hose joint clicks.

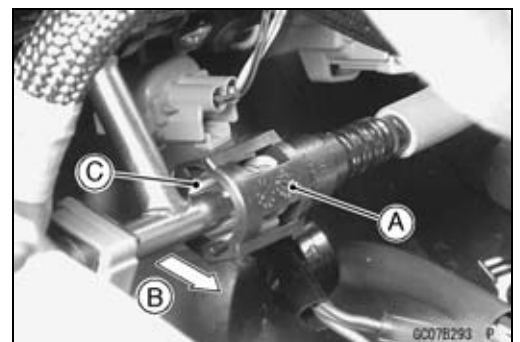

### **⚠ WARNING**

**Make sure the hose joint is installed correctly on the delivery pipe by sliding the joint, or the fuel could leak.**

## 3-122 FUEL SYSTEM (DFI)

### Nozzle Assy

#### Nozzle Assy Disassembly

- Remove the nozzle assy (see Nozzle Assy Removal).
- Remove the screws [A] to pull out the injector assys from the stay plate comp together with the delivery pipe assy.

#### NOTE

○ Do not damage the part of insert of the injectors when they are pulled out from the stay plate comp.

- Remove the fuel hose.
- Pull out the injectors from the delivery pipe assy.

#### NOTE

○ Do not damage the part of insert of the injectors when they are pulled out from the delivery pipe assy.

#### Nozzle Assy Assembly

- Before assembling, blow away dirt or dust from the nozzle and delivery pipes [A] by applying compressed air [B].

- Apply engine oil to the new O-rings [A] and the dust seals [B] of each injector.

#### NOTE

○ Replace the O-ring and the dust seals of injectors to new one.

- Apply engine oil to the new O-rings [A].
- Install the joint pipe [B] to the delivery pipe.

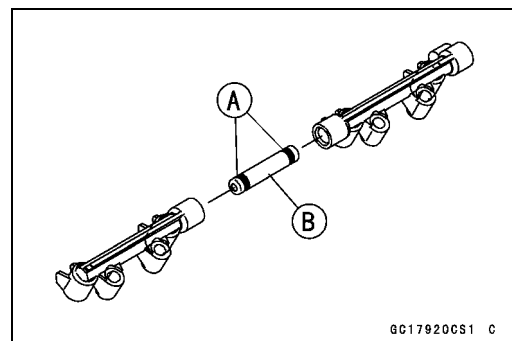
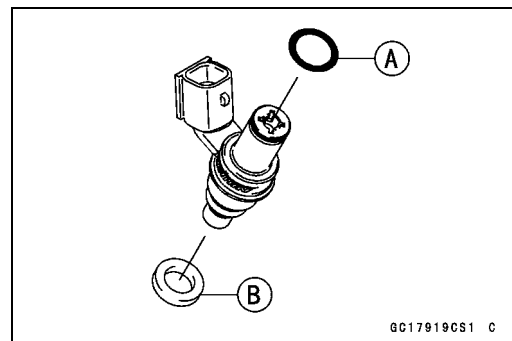
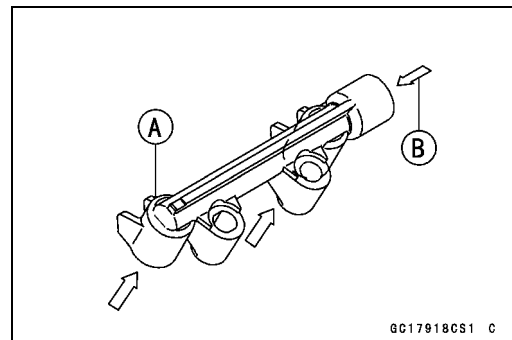
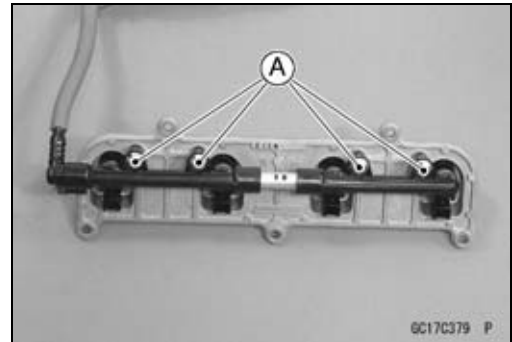

**Nozzle Assy**

- Apply engine oil to the new O-rings [A].
- Fit the connector portion [B] of the injector to the slot [C] of delivery pipe.

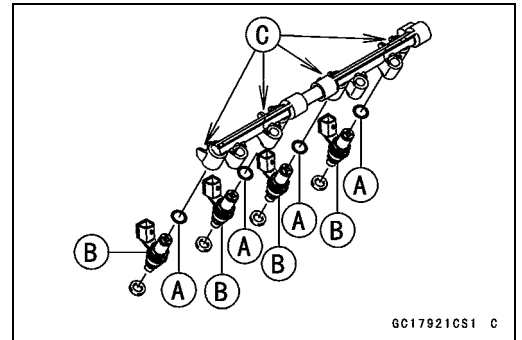

- Apply engine oil to the new dust seals [A].
- Insert the delivery pipe assy in the stay plate.

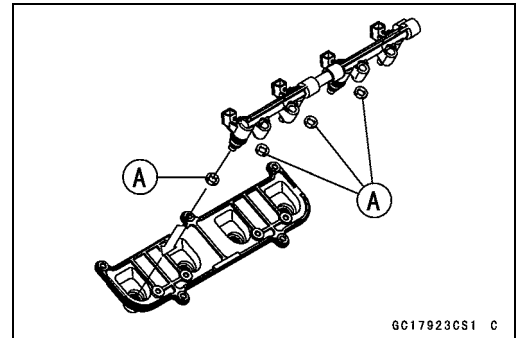

- Tighten the screws [A].  
**Torque - Delivery Pipe Mounting Screws: 3.4 N·m (0.35 kgf·m, 30 in·lb)**

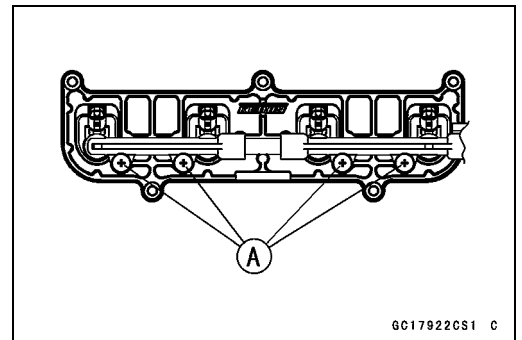

- Apply engine oil to the new O-ring [A].
- Tighten:  
**Torque - Fuel Hose Mounting Screw [B]: 4.9 N·m (0.50 kgf·m, 43 in·lb)**
- Check the injector fuel line for leakage (see Injector Fuel Line Inspection).

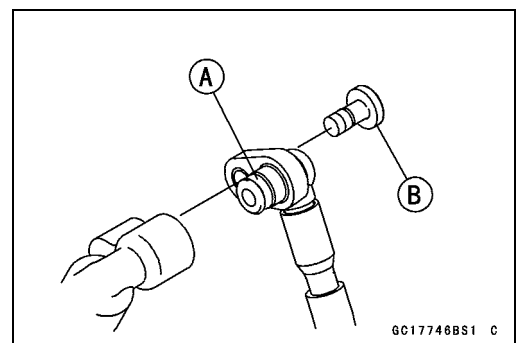

## 3-124 FUEL SYSTEM (DFI)

### Air Cleaner

#### **Air Cleaner Element Removal**

- Refer to the Air Cleaner Element Replacement in the Periodic Maintenance chapter (see Air Cleaner Element Replacement in the Periodic Maintenance chapter).

#### **Air Cleaner Element Installation**

- Refer to the Air Cleaner Element Replacement in the Periodic Maintenance chapter (see Air Cleaner Element Replacement in the Periodic Maintenance chapter).

#### **Air Cleaner Element Inspection**

- Remove the air cleaner element (see Air Cleaner Element Replacement in the Periodic Maintenance chapter).
- Visually check the element [A] for tears or breaks.
- ★ If the element has any tears or breaks, replace the element.

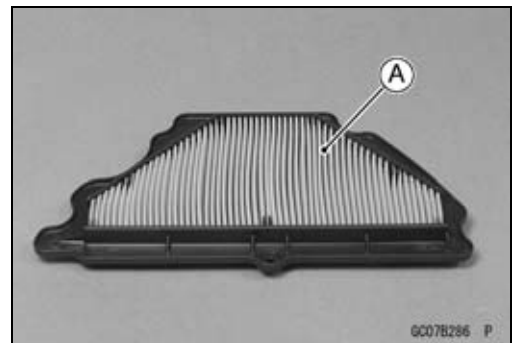

#### **Air Cleaner Housing Removal**

- Remove the front side bolt of the fuel tank.
- Set up the fuel tank [A] using the suitable tool or bar [A].
- Position the steering straight.

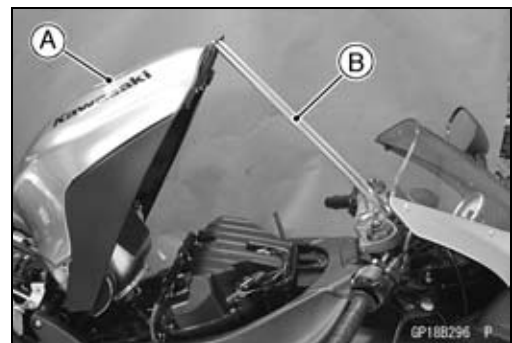

- Remove:
  - Hose Joint (see Nozzle Assy Removal)
  - Inlet Air Temperature Sensor Connector [A]
  - Inlet Air Pressure Sensor [B]
  - Nozzle Assy Lead Connectors [C]

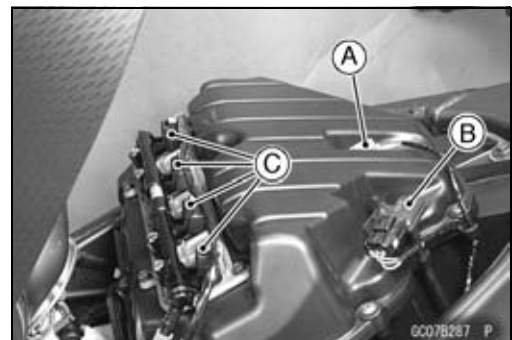

- Remove:
  - Air Cleaner Housing Bolt [A]
  - Plugs [B]

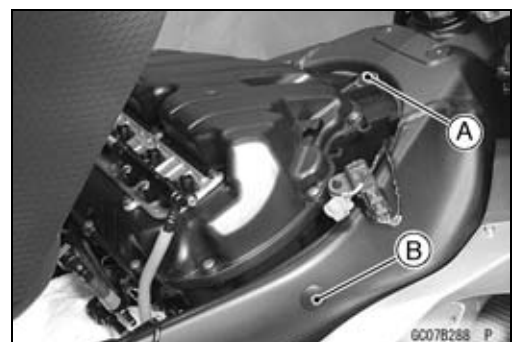

## Air Cleaner

- Loosen:  
Air Cleaner Housing Clamp Bolts [A]

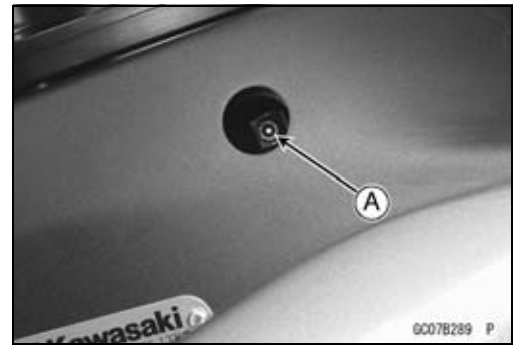

- Remove:  
Clamp [A]  
Engine Breather Hose [B]  
Clamp [C]  
Drain Hose [D]

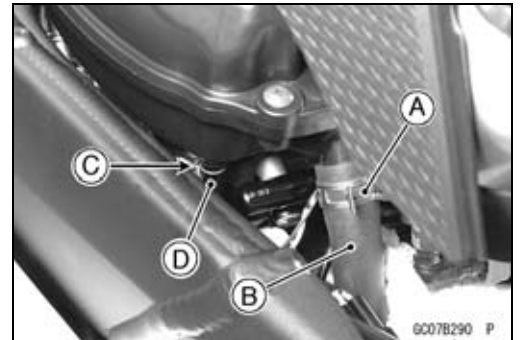

- Remove the air switching valve hose [A].



### ***Air Cleaner Housing Installation***

- Install the vacuum switch valve hose to the air cleaner housing.
- Install the air cleaner housing on the throttle body assy.
- Install the clamp bolt heads [A] outside as shown.
- Push in the ducts [B] touch the stopper [C] of the throttle body.
- Tighten:  
  - Torque - Air Cleaner Housing Clamp Bolts: 2.0 N·m (0.20 kgf·m, 17 in·lb)**
  - Air Cleaner Housing Mounting Bolt: 6.9 N·m (0.70 kgf·m, 61 in·lb)**

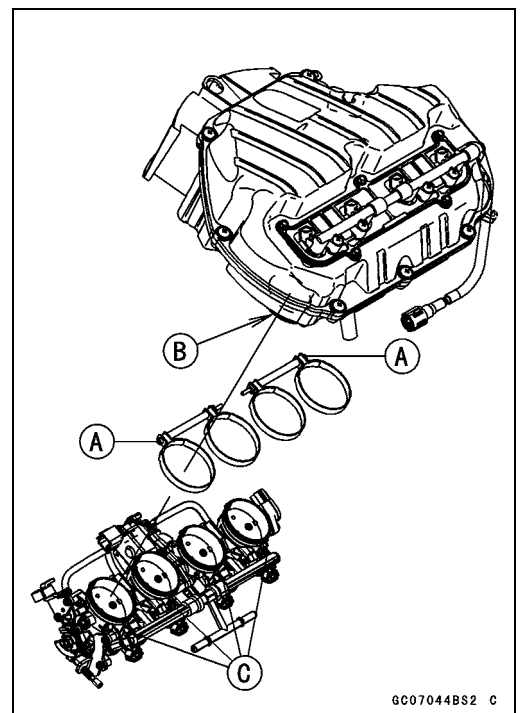

- Install:  
Drain and Engine Breather Hoses  
Hose Joint (see Nozzle Assy Installation)

## 3-126 FUEL SYSTEM (DFI)

### Air Cleaner

- Install:
  - Inlet Air Temperature Sensor [A]
  - Inlet Air Pressure Sensor [B]
  - Hooks [C]
- Run the harness and hose as shown.

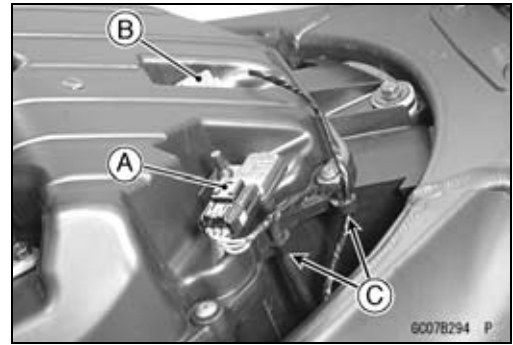

### Air Cleaner Housing Disassembly

- Remove:
  - Air Cleaner Housing (see Air Cleaner Housing Removal)
  - Inlet Air Temperature Sensor
  - Nozzle Assy [A] (see Nozzle Assy Removal)
  - Clamps [B]
  - Ducts [C]
- Remove the air cleaner element (see Air Cleaner Element Replacement in the Periodic Maintenance chapter).

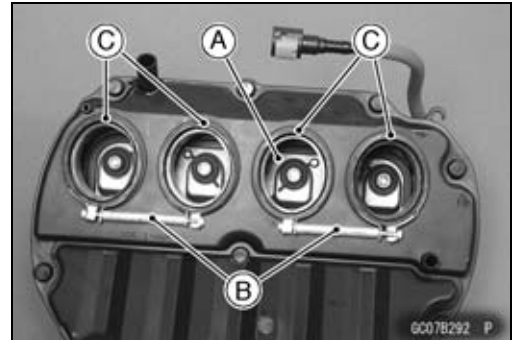

### Air Cleaner Housing Assembly

- Fit the projections [A] of the duct into the slits [B] on the air cleaner housing.
- Do not twist the ducts [C].

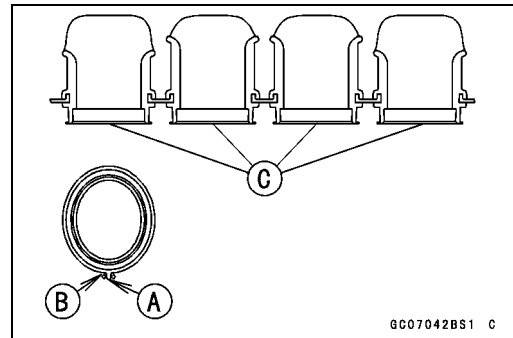

- Install:
  - Air Cleaner Frame Gasket [A]
  - Air Cleaner Case Gasket [B]
  - Air Cleaner Air Element Gasket [C]
  - Air Element [D]
  - Upper Air Cleaner Housing [E]
  - Screws [F]
- Tighten:
  - Torque - Air Cleaner Housing Screws: 1.1 N·m (0.11 kgf·m, 9.7 in·lb)**
- Install:
  - Air Cleaner Housing (see Air Cleaner Housing Installation)

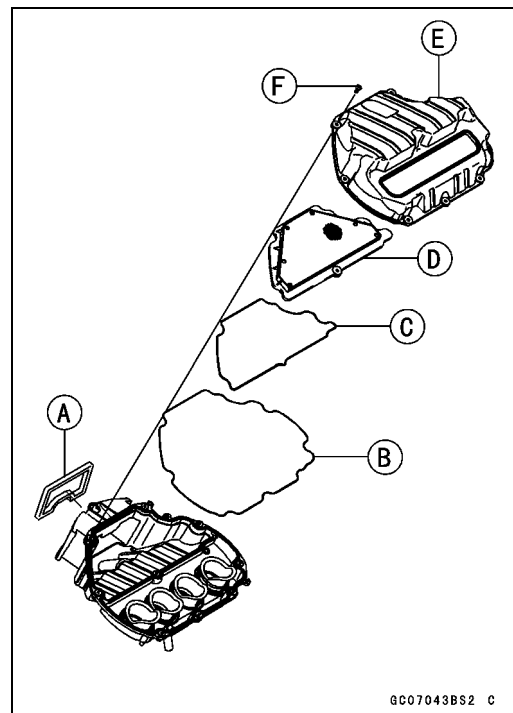



---

**Air Cleaner**

---

**Oil Draining**

A drain hose is connected to the bottom of the air cleaner part to drain water or oil accumulated in the cleaner part.

- Visually check the catch tank end, if the water or oil accumulates in the tank.

- ★ If any water or oil accumulates in the hose, remove the catch tank [A] from the drain hose and drain it.

**⚠ WARNING**

**Be sure reinstall the catch tank in the drain hose after draining. Oil on tires will make them slippery and can cause an accident and injury.**

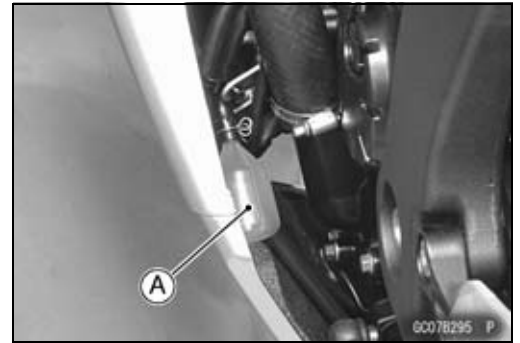

## 3-128 FUEL SYSTEM (DFI)

### Fuel Tank

#### Fuel Tank Removal

#### **⚠ WARNING**

Gasoline is extremely flammable and can be explosive under certain conditions. Make sure the area is well-ventilated and free from any source of flame or sparks; this includes any appliance with a pilot light. Do not smoke. Turn the ignition switch OFF. Be prepared for fuel spillage; any spilled fuel must be completely wiped up immediately.

- Turn the ignition switch OFF.
- Wait until the engine cools down.
- Remove:
  - Fuel Tank Bolts [A]
  
- Remove:
  - Front Seat (see Front Seat Removal in the Frame chapter)
  - Battery (-) Terminal [A]
  - Fuel Tank Bolt [B]
  - Drain Hose [C]
  - Fuel Pump Connector [D]
  - Fuel Return Hose (Red, California model only)
  - Fuel Tank Breather Hose (Blue, California model only)
  
- Open the fuel tank cap [A] to lower the pressure in the tank.
  
  
- Draw the fuel out from the fuel tank with a commercially available pump [A].
  - Use a soft plastic hose [B] as a pump inlet hose in order to insert the hose smoothly.
  - Put the hose through the fill opening [C] into the tank and draw the fuel out.
    - Front [D]

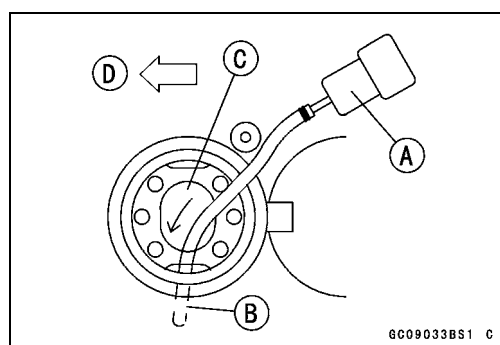
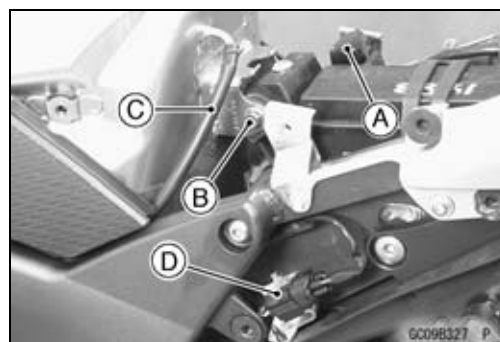

#### **⚠ WARNING**

The fuel could not be removed completely from the fuel tank. Be careful for remained fuel spillage.

**Fuel Tank**

- Be sure to place a piece of cloth [A] around the fuel hose joint [B].
- Insert the (-) screw driver into the slot [C] of the joint lock.

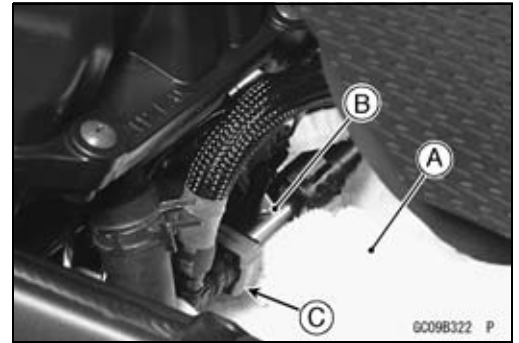

- Pull the joint lock [A] as shown.
- Pull the fuel hose joint [B] out of the delivery pipe.

**⚠ WARNING**

**Be prepared for fuel spillage; any spilled fuel must be completely wiped up immediately. When the fuel hose is disconnected, fuel spills out from the hose and the pipe because of residual pressure. Cover the hose connection with a piece of clean cloth to prevent fuel spillage.**

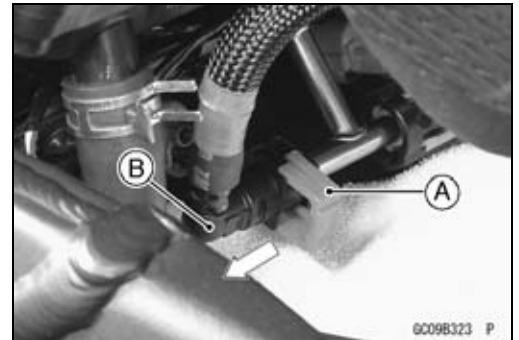

- Close the fuel tank cap.
- Remove the fuel tank, and place it on a flat surface.
- For California Model, note the following.

**CAUTION**

**For California model, if gasoline, solvent, water or any other liquid enters the canister, the canister's vapor absorbing capacity is greatly reduced. If the canister does become contaminated, replace it with a new one.**

- Be sure to plug the evaporative fuel return hose to prevent fuel spilling before fuel tank removal.

**⚠ WARNING**

**For California model, be careful not to spill the gasoline through the return hose. Spilled fuel is hazardous.**

- ★ If liquid or gasoline flows into the breather hose, remove the hose and blow it clean with compressed air.
- Be careful of fuel spillage from the fuel tank since fuel still remains in the fuel tank and fuel pump.

**⚠ WARNING**

**Store the fuel tank in an area which is well-ventilated and free from any source of flame or sparks. Do not smoke in this area. Place the fuel tank on a flat surface and plug the fuel pipes to prevent fuel leakage.**

## 3-130 FUEL SYSTEM (DFI)

### Fuel Tank

#### **Fuel Tank Installation**

- Note the above WARNING (see Fuel Tank Removal).
- Route the hoses correctly (see Cable, Wire, and Hose Routing section in the Appendix chapter).
- For California Model, note the following.
  - To prevent the gasoline from flowing into or out of the canister, hold the separator perpendicular to the ground.
  - Connect the hoses according to the diagram of the system (see Cable, Wire, and Hose Routing section in the Appendix chapter). Make sure they do not get pinched or kinked.
  - Route hoses with a minimum of bending so that the air or vapor will not be obstructed.
- Set [A] the joint lock as shown.



- Insert the fuel hose joint [A] straight onto the delivery pipe [B] until the hose joint clicks.
- Push the joint lock [C] until the hose joint clicks.

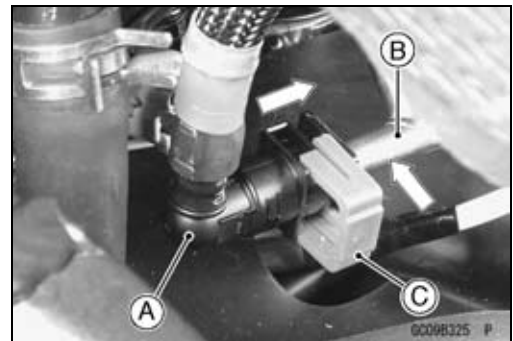

- Connect the fuel pump connector and the battery (–) cable terminal.

#### **Fuel Tank and Cap Inspection**

- Visually inspect the gasket [A] on the tank cap for any damage.
- ★ Replace the gasket if it is damaged.
- Check to see if the water drain pipe [B] and fuel breather pipe [C] (California Model) in the tank are not clogged. Check the tank cap breather also.
- ★ If they are clogged, remove the tank and drain it, and then blow the breather free with compressed air.

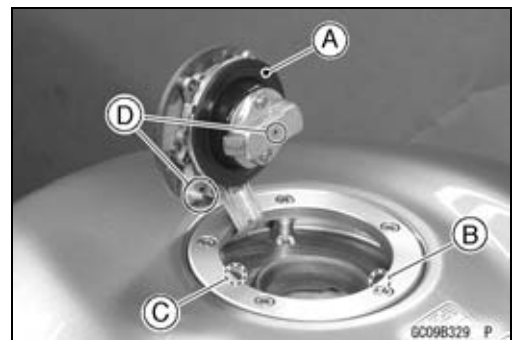

#### **CAUTION**

**Do not apply compressed air to the air vent holes [D] in the tank cap. This could cause damage and clogging of the labyrinth in the cap.**

---

**Fuel Tank**

---

***Fuel Tank Cleaning*****⚠ WARNING**

**Clean the tank in a well-ventilated area, and take care that there are no sparks or flame anywhere near the working area. Because of the danger or highly flammable liquids, do not use gasoline or low-flash point solvents to clean the tank.**

- Remove the fuel tank (see Fuel Tank Removal).
- Remove the fuel pump (see Fuel Pump Removal).
- Pour some high-flash point solvent into the fuel tank and shake the tank to remove dirt and fuel deposits.
- Draw the solvent out of the fuel tank.
- Dry the tank with compressed air.
- Install the fuel pump (see Fuel Pump Installation).
- Install the fuel tank (see Fuel Tank Installation).

## 3-132 FUEL SYSTEM (DFI)

### Evaporative Emission Control System (California Model)

The Evaporative Emission Control System routes fuel vapors from the fuel system into the running engine or stores the vapors in a canister when the engine is stopped. Although no adjustments are required, a thorough visual inspection must be made at the intervals specified by the Periodic Maintenance Chart.

#### **Parts Removal/Installation**

#### **⚠ WARNING**

**Gasoline is extremely flammable and can be explosive under certain conditions. Turn the ignition switch OFF. Do not smoke. Make sure the area is well-ventilated and free from any source of flame or sparks; this includes any appliance with a pilot light.**

#### **CAUTION**

**If gasoline, solvent, water or any other liquid enters the canister, the canister's vapor absorbing capacity is greatly reduced. If the canister does become contaminated, replace it with a new one.**

- To prevent the gasoline from flowing into or out of the canister, hold the separator perpendicular to the ground.
- Connect the hoses according to the diagram of the system (see Cable, Wire, and Hose Routing section in the Appendix chapter). Make sure they do not get pinched or kinked.

#### **Hose Inspection**

- Refer to the Evaporative Emission Control System Inspection in the Periodic Maintenance chapter.

#### **Separator Inspection**

- Refer to the Evaporative Emission Control System Inspection in the Periodic Maintenance chapter.  
Separator [A]



Evaporative Emission Control System (California Model)

Separator Operation Test

**⚠ WARNING**

Gasoline is extremely flammable and can be explosive under certain conditions. Turn the ignition switch OFF. Do not smoke. Make sure the area is well-ventilated and free from any source of flame or sparks; this includes any appliance with a pilot light.

- Connect the hoses to the separator, and install the separator on the motorcycle.
- Disconnect the breather hose from the separator, and inject about 20 mL (0.68 US oz.) of gasoline [A] into the separator [B] through the hose fitting.
- Disconnect the fuel return hose [C] from the fuel tank [D].
- Run the open end of the return hose into the container and hold it level with the tank top [E].
- Start the engine, and let it idle.
- ★ If the gasoline in the separator comes out of the hose, the separator works well. If it does not, replace the separator with a new one.

**Canister Inspection**

- Refer to the Evaporative Emission Control System Inspection in the Periodic Maintenance chapter.

**NOTE**

○ The canister [A] is designed to work well through the motorcycle's life without any maintenance if it is used under normal conditions.

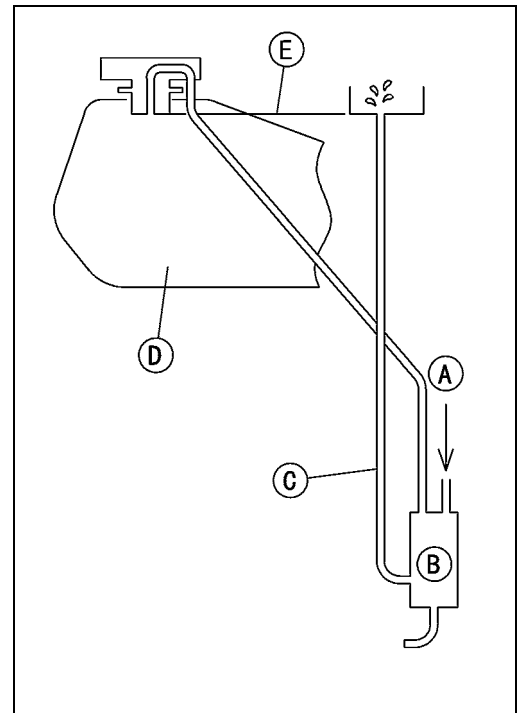





# Cooling System

## Table of Contents

Exploded View .....	4-2
Specifications .....	4-4
Special Tools .....	4-5
Coolant Flow Chart.....	4-6
Coolant .....	4-8
Coolant Deterioration Inspection.....	4-8
Coolant Level Inspection.....	4-8
Coolant Draining .....	4-8
Coolant Filling .....	4-8
Pressure Testing .....	4-8
Cooling System Flushing .....	4-9
Coolant Reserve Tank Removal .....	4-9
Coolant Reserve Tank Installation .....	4-10
Water Pump.....	4-11
Water Pump Removal.....	4-11
Water Pump Installation .....	4-11
Water Pump Impeller Disassembly/Assembly .....	4-11
Water Pump Impeller Inspection.....	4-11
Water Pump Housing Disassembly .....	4-11
Water Pump Housing Assembly .....	4-12
Mechanical Seal Inspection .....	4-12
Radiator.....	4-13
Radiator and Radiator Fan Removal .....	4-13
Radiator and Radiator Fan Installation .....	4-14
Radiator Inspection .....	4-16
Radiator Cap Inspection .....	4-16
Radiator Filler Neck Inspection.....	4-17
Thermostat .....	4-18
Thermostat Removal.....	4-18
Thermostat Installation.....	4-18
Thermostat Inspection .....	4-19
Hoses and Pipes .....	4-20
Hose Installation .....	4-20
Hose Inspection .....	4-20
Water Temperature Sensor .....	4-21
Water Temperature Sensor Removal.....	4-21
Water Temperature Sensor Inspection .....	4-21

# 4-2 COOLING SYSTEM

## Exploded View

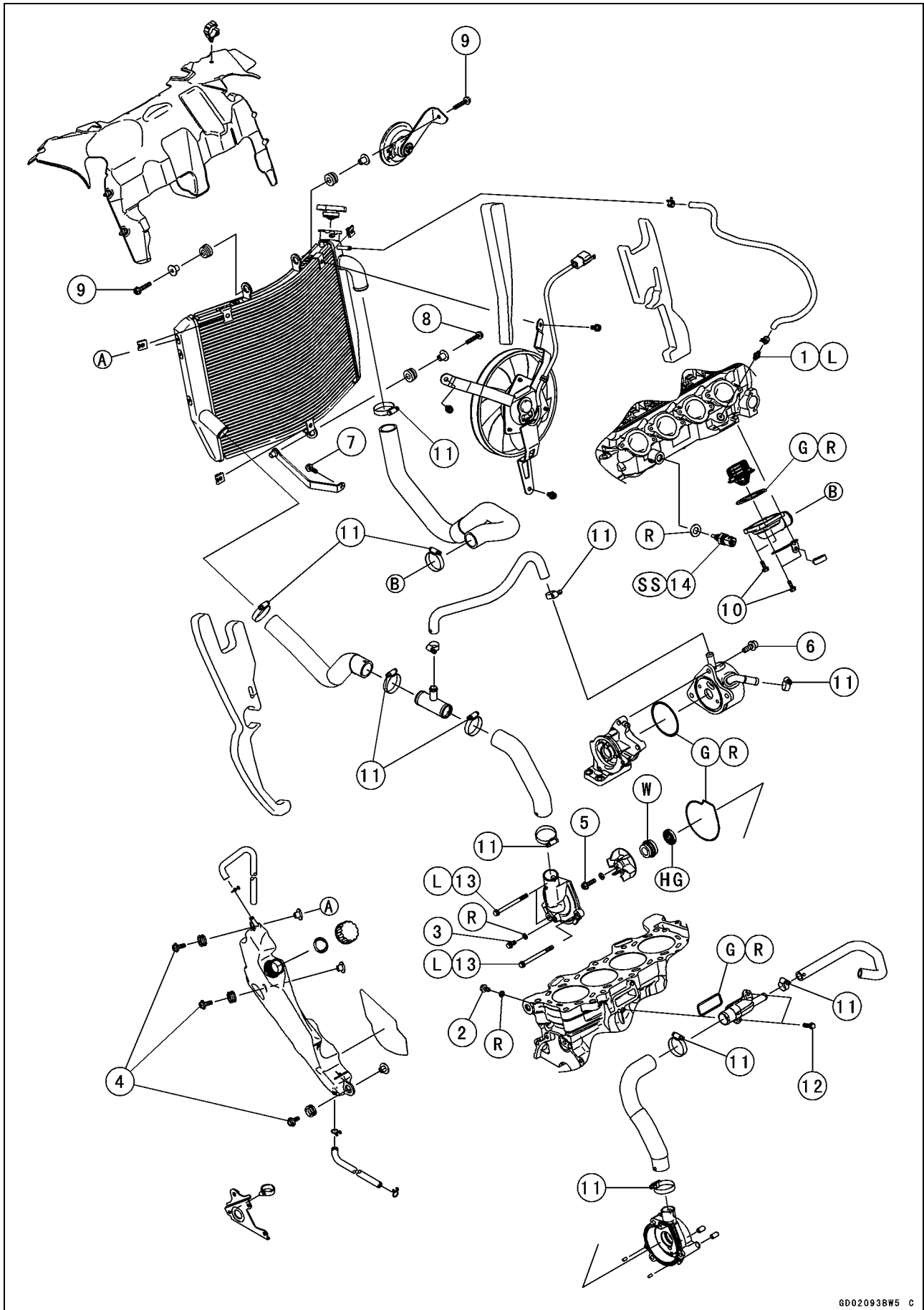

**Exploded View**

No.	Fastener	Torque			Remarks
		N-m	kgf-m	ft-lb	
1	Coolant By-pass Fitting Bolt	8.8	0.90	78 in-lb	L
2	Coolant Drain Bolt (Cylinder)	9.8	1.0	87 in-lb	
3	Coolant Drain Bolt (Water Pump)	8.8	0.90	78 in-lb	
4	Coolant Reserve Tank Mounting Bolts	7.0	0.70	61 in-lb	
5	Impeller Bolt	9.8	1.0	87 in-lb	
6	Oil Cooler Mounting Bolts	20	2.0	15	
7	Radiator Bracket Mounting Bolt	9.8	1.0	87 in-lb	
8	Radiator Lower Bolt	6.9	0.70	61 in-lb	
9	Radiator Upper Bolts	9.8	1.0	87 in-lb	
10	Thermostat Housing Cover Bolts	5.9	0.60	52 in-lb	
11	Water Hose Clamp Screws	2.0	0.20	17 in-lb	
12	Water Hose Fitting Bolts (Cylinder)	9.8	1.0	87 in-lb	
13	Water Pump Cover Bolts	12	1.2	106 in-lb	L
14	Water Temperature Sensor	25	2.5	18	SS

G: Apply grease.

HG: Apply high-temperature grease.

L: Apply a non-permanent locking agent.

R: Replacement Parts

S: Follow the specified tightening sequence.

SS: Apply silicone sealant.

W: Apply coolant.

## 4-4 COOLING SYSTEM

### Specifications

Item	Standard
<b>Coolant Provided when Shipping</b> Type (Recommended) Color Mixed Ratio Freezing Point Total Amount	Permanent type of antifreeze (soft water and ethylene glycol plus corrosion and rust inhibitor chemicals for aluminum engines and radiators) Green Soft water 50%, coolant 50% -35°C (-31°F) 2.6 L (2.7 US qt) (Reserve tank full level, including radiator and engine)
<b>Radiator Cap</b> Relief Pressure	93 ~ 123 kPa (0.95 ~ 1.25 kgf/cm <sup>2</sup> , 13 ~ 18 psi)
<b>Thermostat</b> Valve Opening Temperature Valve Full Opening Lift	58 ~ 62°C (136 ~ 144°F) 8 mm (0.31 in.) or more @75°C (167°F)

**Special Tools**

**Bearing Driver,  $\phi$ 32:  
57001-382**

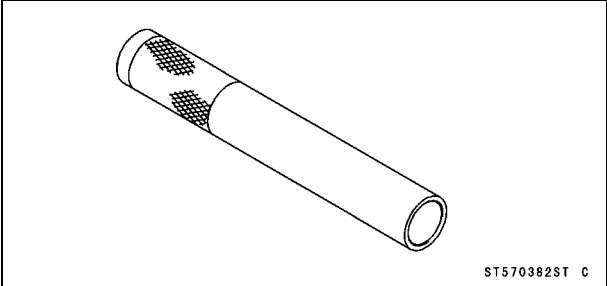

**Bearing Driver Set:  
57001-1129**

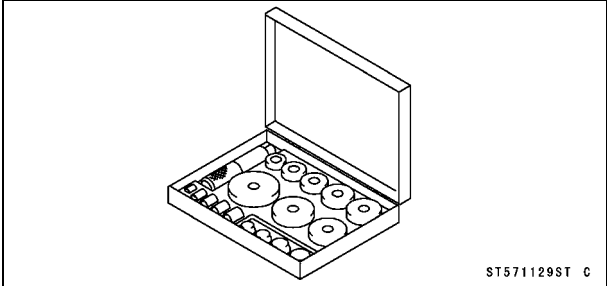

# 4-6 COOLING SYSTEM

## Coolant Flow Chart

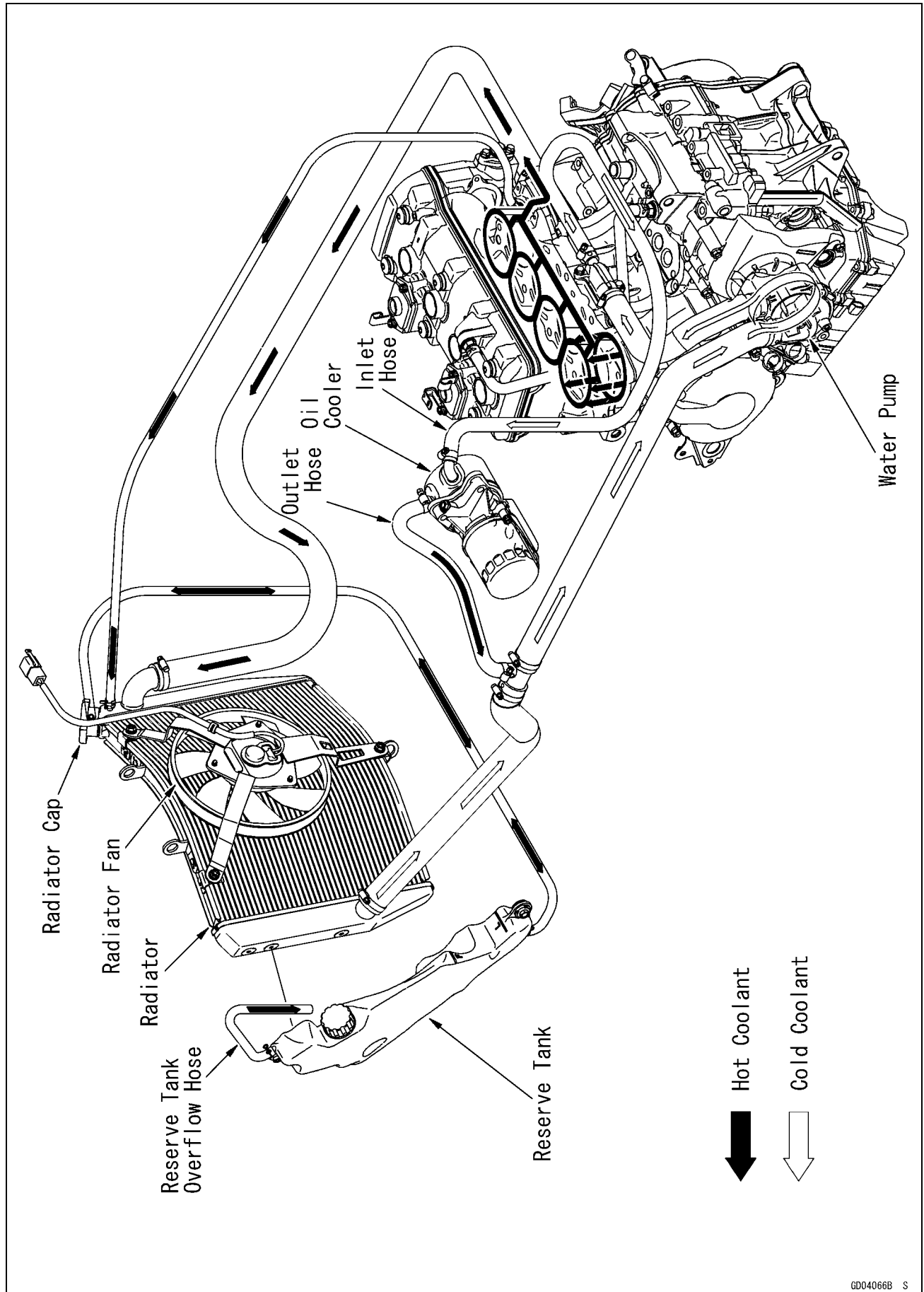

---

**Coolant Flow Chart**

---

Permanent type antifreeze is used as a coolant to protect the cooling system from rust and corrosion. When the engine starts, the water pump turns and the coolant circulates.

The thermostat is a wax pellet type which opens or closes with coolant temperature changes. The thermostat continuously changes its valve opening to keep the coolant temperature at the proper level. When coolant temperature is less than 55°C (131°F), the thermostat closes so that the coolant flow is restricted through the air bleeder hole, causing the engine to warm up more quickly. When coolant temperature is more than 58 ~ 62°C (136 ~ 144°F), the thermostat opens and the coolant flows.

When the coolant temperature goes up beyond 100°C (212°F), the radiator fan relay conducts to operate the radiator fan. The radiator fan draws air through the radiator core when there is not sufficient air flow such as at low speeds. This increases up the cooling action of the radiator. When the coolant temperature is below 97°C (207°F), the fan relay opens and the radiator fan stops.

In this way, this system controls the engine temperature within narrow limits where the engine operates most efficiently even if the engine load varies.

The system is pressurized by the radiator cap to suppress boiling and the resultant air bubbles which can cause engine overheating. As the engine warms up, the coolant in the radiator and the water jacket expands. The excess coolant flows through the radiator cap and hose to the reserve tank to be stored there temporarily. Conversely, as the engine cools down, the coolant in the radiator and the water jacket contracts, and the stored coolant flows back to the radiator from the reserve tank.

The radiator cap has two valves. One is a pressure valve which holds the pressure in the system when the engine is running. When the pressure exceeds 93 ~ 123 kPa (0.95 ~ 1.25 kgf/cm<sup>2</sup>, 13 ~ 18 psi), the pressure valve opens and releases the pressure to the reserve tank. As soon as pressure escapes, the valve closes, and keeps the pressure at 93 ~ 123 kPa (0.95 ~ 1.25 kgf/cm<sup>2</sup>, 13 ~ 18 psi). When the engine cools down, another small valve (vacuum valve) in the cap opens. As the coolant cools, the coolant contracts to form a vacuum in the system. The vacuum valve opens and allows the coolant from the reserve tank to enter the radiator.

## 4-8 COOLING SYSTEM

### Coolant

#### **Coolant Deterioration Inspection**

- Visually inspect the coolant in the reserve tank.
- ★ If whitish cotton-like wafts are observed, aluminum parts in the cooling system are corroded. If the coolant is brown, iron or steel parts are rusting. In either case, flush the cooling system.
- ★ If the coolant gives off an abnormal smell, check for a cooling system leak. It may be caused by exhaust gas leaking into the cooling system.

#### **Coolant Level Inspection**

- Refer to the Coolant Level Inspection in the Periodic Maintenance chapter.

#### **Coolant Draining**

- Refer to the Coolant Change in the Periodic Maintenance chapter.

#### **Coolant Filling**

- Refer to the Coolant Change in the Periodic Maintenance chapter.

#### **Pressure Testing**

- Remove:
  - Right Inner Cover (see Inner Cover Removal in the Frame chapter)
  - Radiator Cap [A]
- Remove the radiator cap in two steps. First turn the cap counterclockwise to the first stop. Then push and turn it further in the same direction and remove the cap.

- Install the cooling system pressure tester [A] on the filler neck.

#### **NOTE**

- Wet the cap sealing surfaces with water or coolant to prevent pressure leaks.

- Build up pressure in the system carefully until the pressure reaches 123 kPa (1.25 kgf/cm<sup>2</sup>, 18 psi).

#### **CAUTION**

**During pressure testing, do not exceed the pressure for which the system is designed. The maximum pressure is 123 kPa (1.25 kgf/cm<sup>2</sup>, 18 psi).**

- Watch the gauge for at least 6 seconds.
- ★ If the pressure holds steady, the system is all right.
- ★ If the pressure drops and no external source is found, check for internal leaks. Droplets in the engine oil indicate internal leakage. Check the cylinder head gasket and the water pump.
- Remove the pressure tester, replenish the coolant, and install the radiator cap.

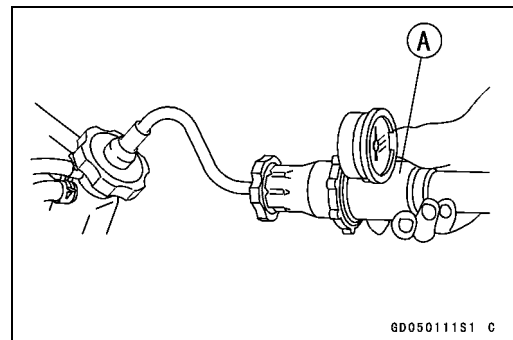



## Coolant

### Cooling System Flushing

Over a period of time, the cooling system accumulates rust, scale, and lime in the water jacket and radiator. When this accumulation is suspected or observed, flush the cooling system. If this accumulation is not removed, it will clog up the water passage and considerably reduce the efficiency of the cooling system.

- Drain the coolant (see Coolant Change in the Periodic Maintenance chapter).
- Fill the cooling system with fresh water mixed with a flushing compound.

#### CAUTION

**Do not use a flushing compound which is harmful to the aluminum engine and radiator. Carefully follow the instructions supplied by the manufacturer of the cleaning product.**

- Warm up the engine, and run it at normal operating temperature for about ten minutes.
- Stop the engine, and drain the cooling system.
- Fill the system with fresh water.
- Warm up the engine and drain the system.
- Repeat the previous two steps once more.
- Fill the system with a permanent type coolant and bleed the air from the system (see Coolant Change in the Periodic Maintenance chapter).

### Coolant Reserve Tank Removal

- Remove:
  - Left Middle Fairing (see Middle Fairing Removal in the Frame chapter)
  - Coolant Reserve Tank Mounting Bolts [A]
- Remove the cap [B] and pour the coolant into a container.
- Remove:
  - Radiator Overflow Hose [C]
  - Reserve Tank Overflow Hose [D]
  - Coolant Reserve Tank [E]

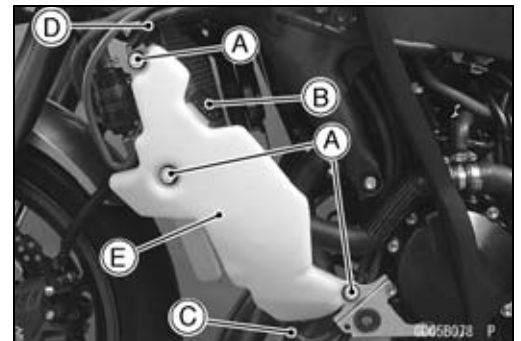

## 4-10 COOLING SYSTEM

### Coolant

#### **Coolant Reserve Tank Installation**

- Be sure that the pad [A] is in position on the coolant reserve tank [B].
- Install the following to the coolant reserve tank.
  - Rubber Dampers [C]
  - Collars [D]
  - Gasket [E]
  - Cap [F]
- Tighten:
  - Torque - Coolant Reserve Tank Mounting Bolts [G]: 7.0 N·m (0.70 kgf·m, 61 in·lb)**
- Run the hoses correctly (see Cable, Wire, and Hose Routing section in the Appendix chapter).
- Fill the coolant reserve tank with coolant (see Coolant Change in the Periodic Maintenance chapter).

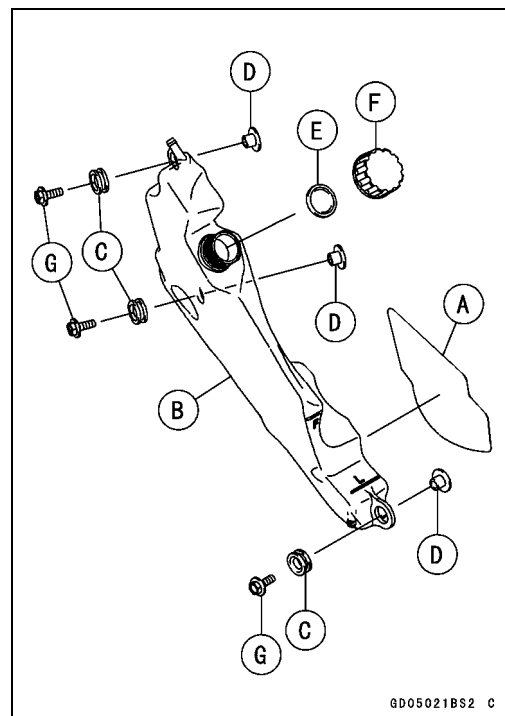

## Water Pump

### Water Pump Removal

- Refer to the Oil Pump Removal in the Engine Lubrication System chapter.

### Water Pump Installation

- Refer to the Oil Pump Installation in the Engine Lubrication System chapter.

### Water Pump Impeller Disassembly/Assembly

- Remove the impeller (see Oil Pump Removal in the Engine Lubrication System chapter).
- The sealing seat and rubber seal may be removed easily by hand.
- Apply coolant around the surfaces of the rubber seal and sealing seat.
- Install the rubber seal [A] and sealing seat [B] into the impeller by pressing them by hand until the seat stops at the bottom of the hole.
- Tighten the impeller bolt with the specified torque.

**Torque - Impeller Bolt: 9.8 N·m (1.0 kgf·m, 87 in·lb)**

### Water Pump Impeller Inspection

- Remove the left lower fairing (see Lower Fairing Removal in the Frame chapter).
- Check the drainage outlet passage [A] at the bottom of the water pump body for coolant leaks.
- ★ If the mechanical seal is damaged, the coolant leaks through the seal and drains through the passage. Replace the mechanical seal unit (see Water Pump Housing Disassembly/Assembly).

- Remove the water pump cover (see Oil Pump Removal in the Engine Lubrication chapter).
- Visually inspect the impeller [A].
- ★ If the surface is corroded, or if the blades are damaged, replace the impeller.

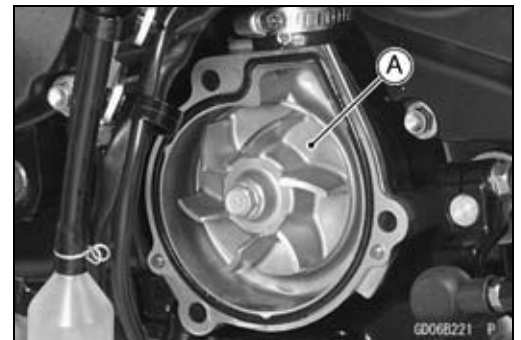
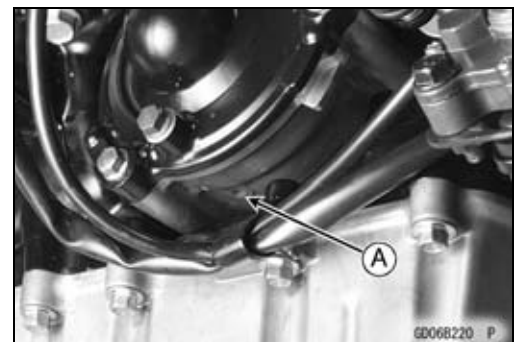
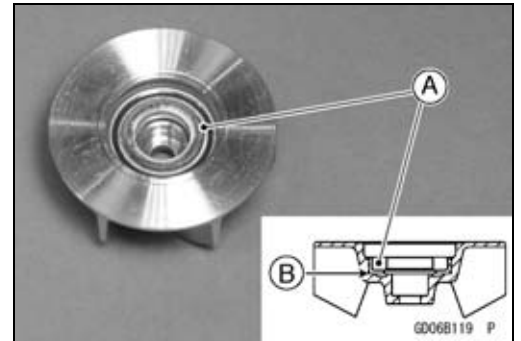

### Water Pump Housing Disassembly

**CAUTION**

**Do not damage the hole wall of the water pump housing.**

- Insert a bar [A] into the pump housing [B], and hammer evenly around the circumference of the mechanical seal bottom [C].

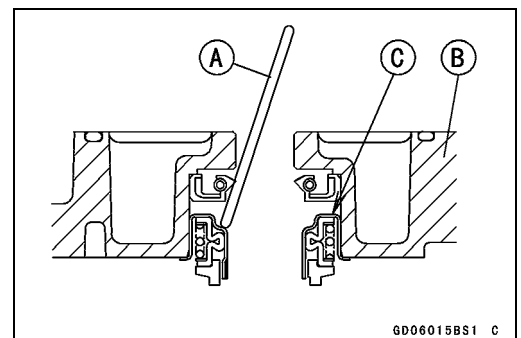

## 4-12 COOLING SYSTEM

### Water Pump

- Take the oil seal [A] out of the housing [B] with a hook [C].

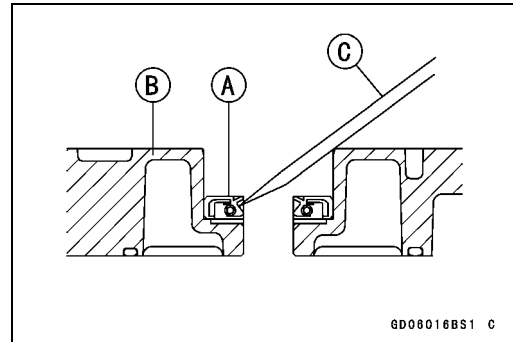

### Water Pump Housing Assembly

#### CAUTION

**Do not reuse the mechanical seal and oil seal.**

- Apply high-temperature grease to the oil seal lips [A].
- Press the new oil seal into the housing with a bearing driver [B] until it stops at the bottom surface [C] of the housing.

**Special Tool - Bearing Driver Set: 57001-1129**

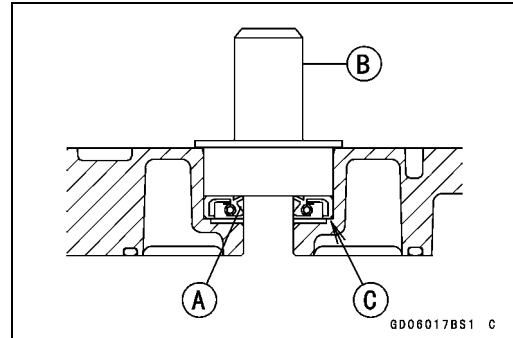

#### CAUTION

**Be careful not to damage the sealing surface of the mechanical seal.**

- Press the new mechanical seal into the housing with stem bearing driver [A] until its flange [B] touches the surface [C] of the housing.

**Special Tool - Bearing Driver,  $\phi 32$ : 57001-382**

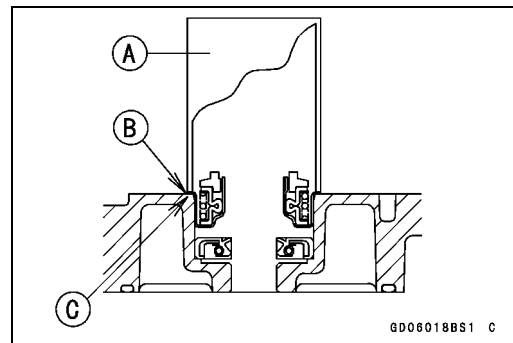

### Mechanical Seal Inspection

- Remove the impeller (see Oil Pump Removal in the Engine Lubrication System chapter).
- Visually inspect the mechanical seal.
- ★ If any one of the parts is damaged, replace the mechanical seal as a unit.

Impeller Sealing Seat Surface [A]

Rubber Seal [B]

Mechanical Seal [C]

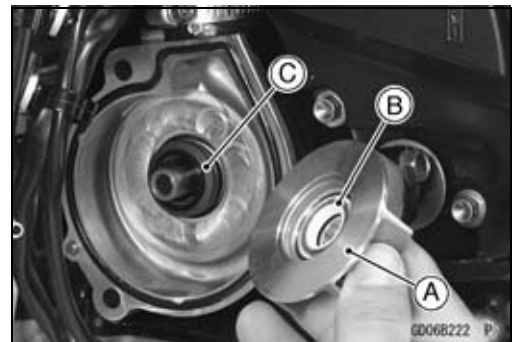

**Radiator**

**Radiator and Radiator Fan Removal**

- Drain the coolant (see Coolant Change in the Periodic Maintenance chapter).
- Remove:
  - Right Middle Fairing (see Middle Fairing Removal in the Frame chapter)
  - Water Hoses [A]
  - Radiator Fan Lead Connector [B]

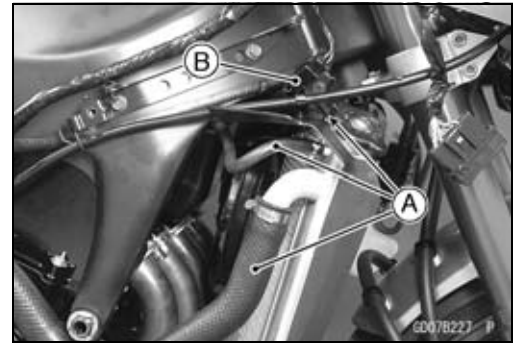

- Remove:
  - Coolant Reserve Tank (see Coolant Reserve Tank Removal)
  - Separator (California Model) [A]
  - Water Hose [B]

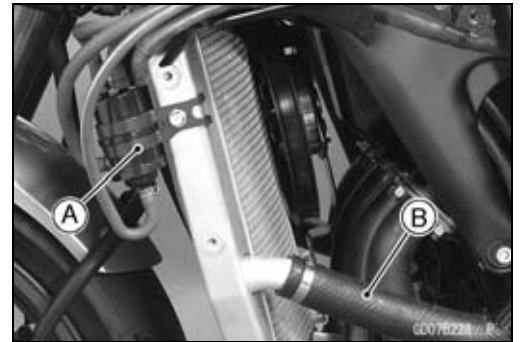

- Remove the radiator lower bolt [A].



- Remove:
  - Right Radiator Upper Bolt [A]
  - Horn [B]

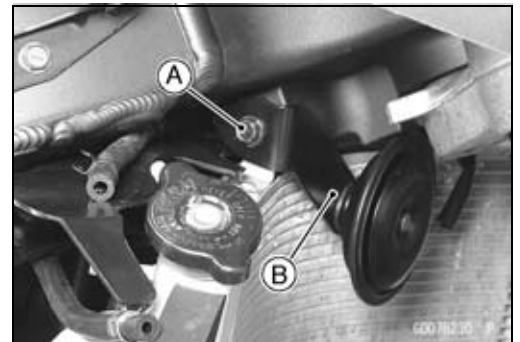

- Remove:
  - Left Radiator Upper Bolt [A]
  - Radiator [B]

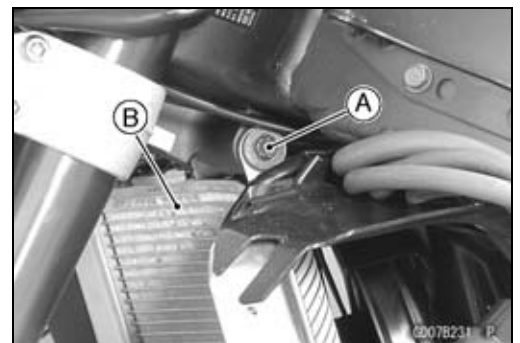

**CAUTION**

**Do not touch the radiator core. This could damage the radiator fins, resulting in loss of cooling efficiency.**

## 4-14 COOLING SYSTEM

### Radiator

○ Remove the bolt [A] and radiator bracket [B] as necessary.

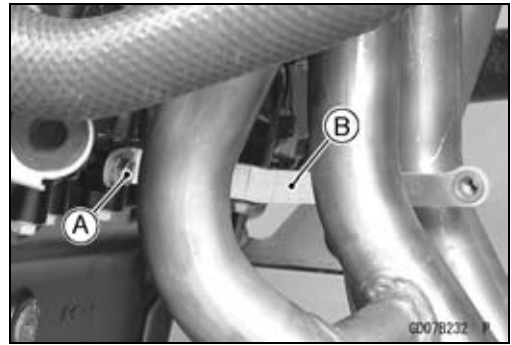

- Remove:
  - Radiator Fan Mounting Bolts [A]
  - Radiator Fan [B]

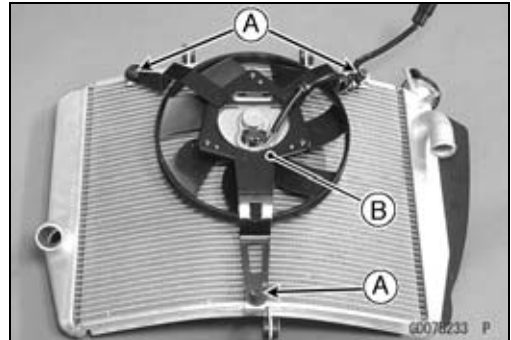

### ***Radiator and Radiator Fan Installation***

- Install the radiator fan [A].
- Install the rubber dampers [B] and collars [C] as shown.

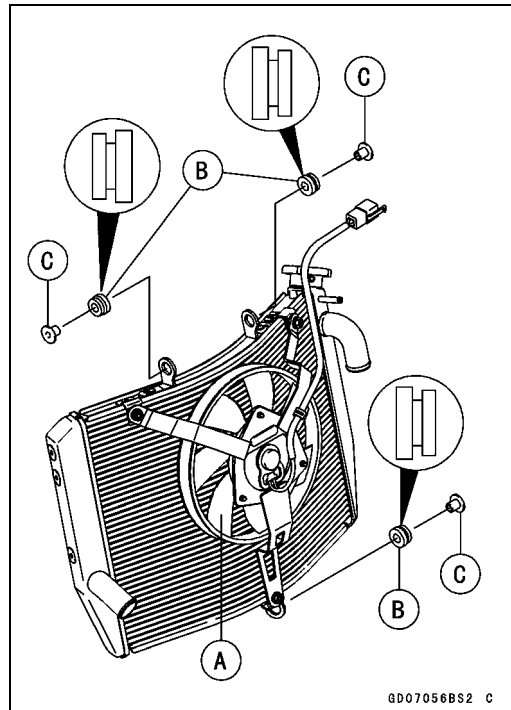

## Radiator

★If the radiator bracket [A] was removed, install it.

**Torque - Radiator Bracket Mounting Bolt [B]: 9.8 N-m (1.0 kgf-m, 87 in-lb)**

● Install the horn [C].

● Tighten:

**Torque - Radiator Upper Bolts [D]: 9.8 N-m (1.0 kgf-m, 87 in-lb)**

**Radiator Lower Bolt [E]: 6.9 N-m (0.70 kgf-m, 61 in-lb)**

● Route the radiator fan lead [F] over the clutch cable [G].

● Face the white marks [H] of the radiator hoses [I] direction as shown.

● Install the water hose clamps [J] as shown.

Upside View [K]

**Torque - Water Hose Clamp Screws : 2.0 N-m (0.20 kgf-m, 17 in-lb)**

● For the California Model, install the separator [L].

**Torque - Separator Bracket Mounting Bolt [M]: 0.8 N-m (0.08 kgf-m, 7 in-lb)**

○Route the canister and separator hoses according to Cable, Wire, and Hose Routing section in the Appendix chapter.

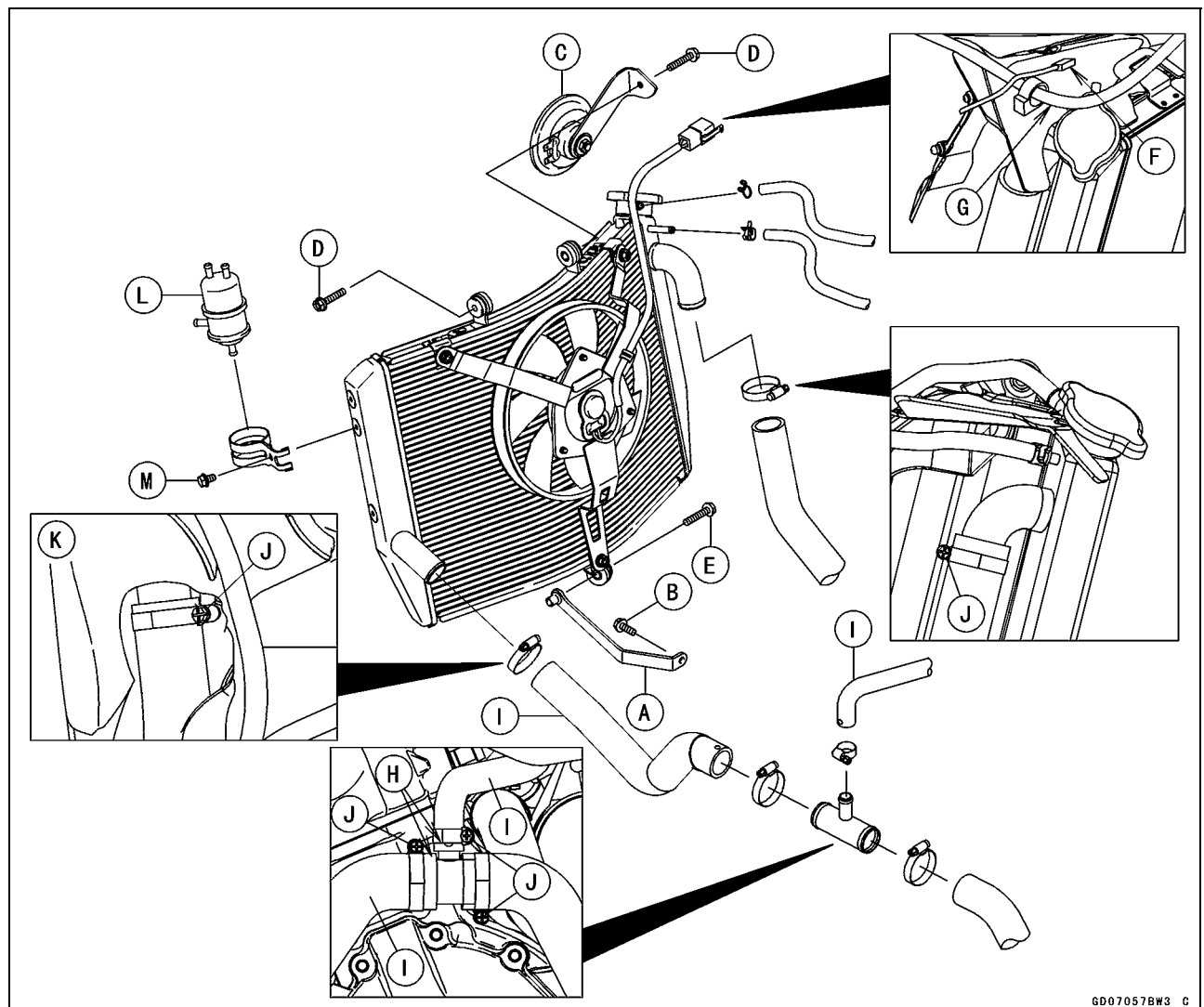

## 4-16 COOLING SYSTEM

### Radiator

#### Radiator Inspection

- Remove the radiator (see Radiator and Radiator Fan Removal).
- Check the radiator core.
- ★ If there are obstructions to air flow, remove them.
- ★ If the corrugated fins [A] are deformed, carefully straighten them.
- ★ If the air passages of the radiator core are blocked more than 20% by unremovable obstructions or irreparably deformed fins, replace the radiator with a new one.

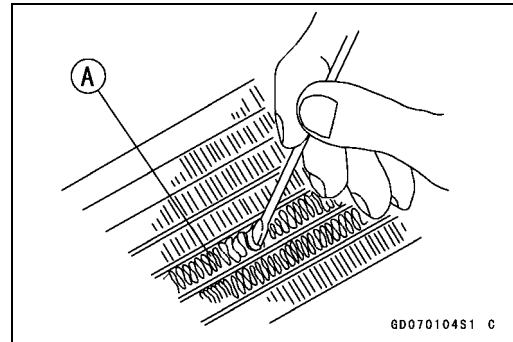

#### CAUTION

When cleaning the radiator with steam cleaner, be careful of the following to prevent radiator damage: Keep the steam gun [A] away more than 0.5 m (1.6 ft) [B] from the radiator core. Hold the steam gun perpendicular [C] (not oblique [D]) to the core surface. Run the steam gun, following the core fin direction.

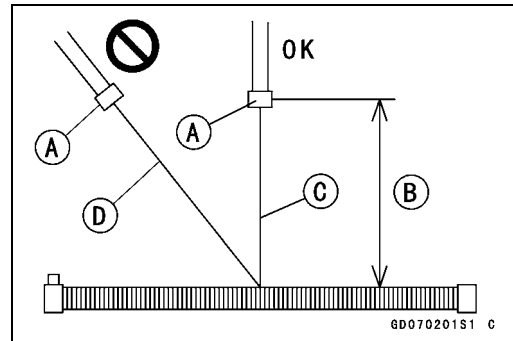

#### Radiator Cap Inspection

- Remove the radiator cap (see Pressure Testing).
- Check the condition of the bottom [A] and top [B] valve seals and valve spring [C].
- ★ If any one of them shows visible damage, replace the cap with a new one.

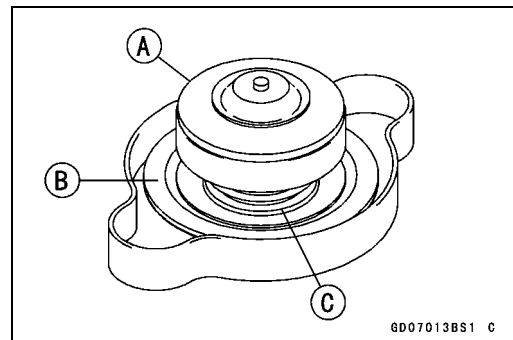

- Install the cap [A] on a cooling system pressure tester [B].

#### NOTE

○ Wet the cap sealing surfaces with water or coolant to prevent pressure leaks.

- Watching the pressure gauge, pump the pressure tester to build up the pressure until the relief valve opens: the gauge needle flicks downward. Stop pumping and measure leak time at once. The relief valve must open within the specified range in the table below and the gauge hand must remain within the same range at least 6 seconds.

#### Radiator Cap Relief Pressure

Standard: 93 ~ 123 kPa (0.95 ~ 1.25 kgf/cm<sup>2</sup>, 13 ~ 18 psi)

- ★ If the cap can not hold the specified pressure or if it holds too much pressure, replace it with a new one.

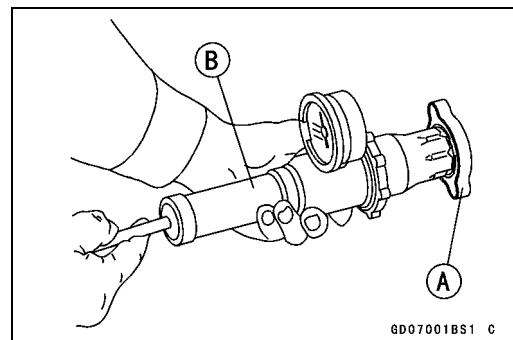



### Radiator

#### ***Radiator Filler Neck Inspection***

- Remove the radiator cap (see Pressure Testing).
- Check the radiator filler neck for signs of damage.
- Check the condition of the top and bottom sealing seats [A] in the filler neck. They must be smooth and clean for the radiator cap to function properly.



## 4-18 COOLING SYSTEM

### Thermostat

#### Thermostat Removal

- Remove:
  - Oil Cooler (see Oil Cooler Removal in the Engine Lubrication System chapter)
  - Water Hose [A]

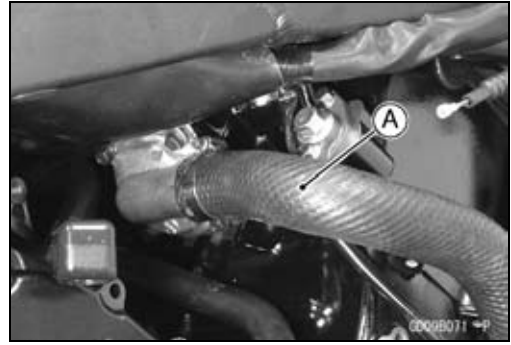

- Remove:
  - Thermostat Housing Cover Bolts [A]
  - Bracket [B]
  - Thermostat Housing Cover [C]
  - Thermostat

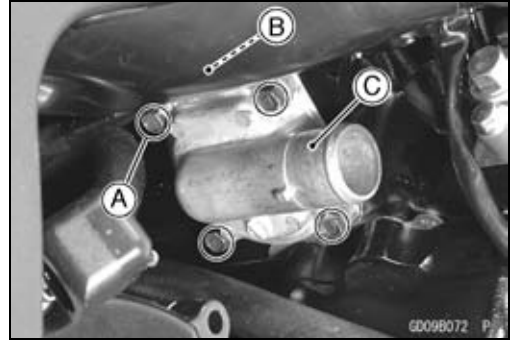

#### Thermostat Installation

- Install the thermostat [A] in the housing so that the air bleeder hole [B] is on top.

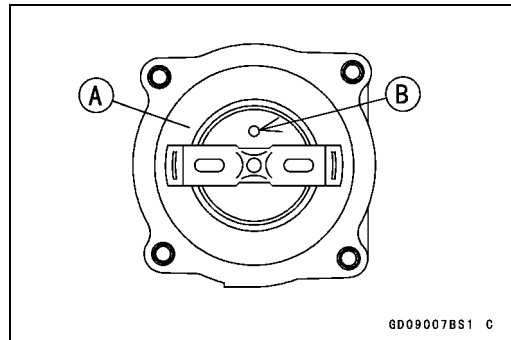

- Install the water hose [A] so that the white mark [B] and the mating surface [C] of thermostat housing cover become parallel.

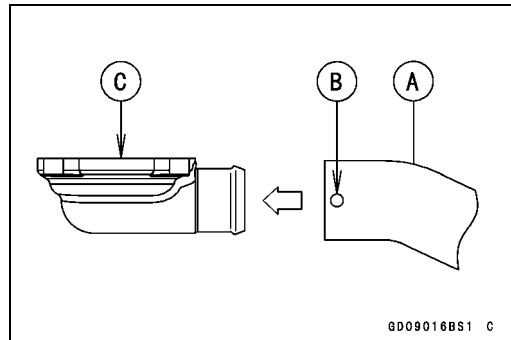

- Replace the O-ring [A] with a new one.
- Apply grease to the new O-ring.
- Install a new O-ring into the thermostat housing cover [B].
- Install the bracket [C].
- Tighten:

**Torque - Thermostat Housing Cover Bolts [D]: 5.9 N·m  
(0.60 kgf·m, 52 in·lb)**

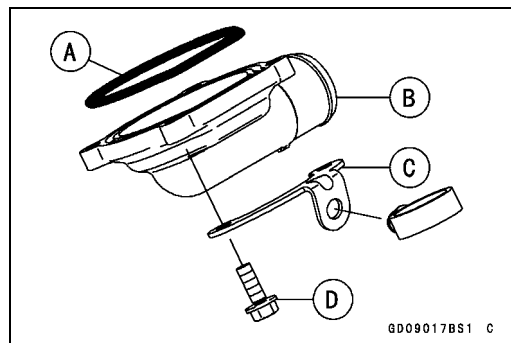

## Thermostat

- Install the water hose clamp [A] as shown.  
Upside View [B]
- Tighten:  
**Torque - Water Hose Clamp Screw: 2.0 N·m (0.20 kgf·m, 17 in·lb)**
- Install the oil cooler (see Oil Cooler Installation in the Engine Lubrication System chapter).
- Fill the radiator with coolant (see Coolant Change in the Periodic Maintenance chapter).

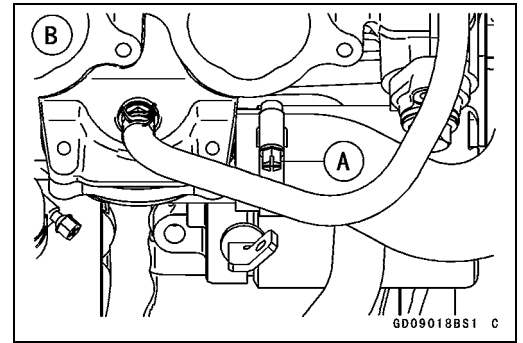

### Thermostat Inspection

- Remove the thermostat (see Thermostat Removal in this chapter).
- Inspect the thermostat valve [A] at room temperature.
- ★ If the valve is open, replace the thermostat with a new one.

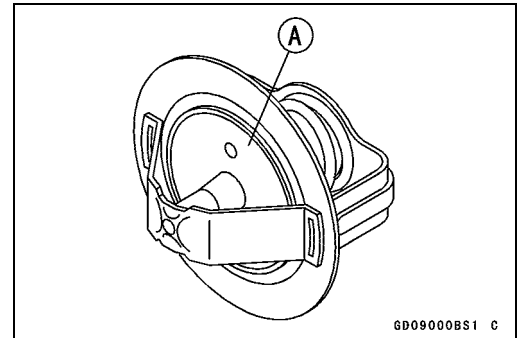

- To check valve opening temperature, suspend the thermostat [A] in a container of water and raise the temperature of the water.
- The thermostat must be completely submerged and must not touch the container sides or bottom. Suspend an accurate thermometer [B] in the water so that the heat sensitive portions [C] are located in almost the same depth. It must not touch the container, either.
- ★ If the measurement is out of the specified range, replace the thermostat with a new one.

### Thermostat Valve Opening Temperature

**Standard: 58 ~ 62°C (136 ~ 144°F)**

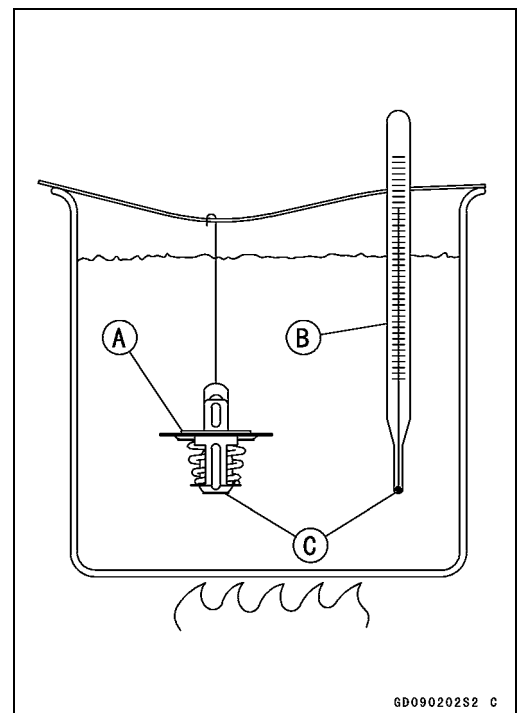

## 4-20 COOLING SYSTEM

### Hoses and Pipes

#### **Hose Installation**

- Install the hoses and pipes, being careful to follow bending direction. Avoid sharp bending, kinking, flattening or twisting.
- Run the hoses in accordance with the Cable, Wire, and Hose Routing section in the Appendix chapter.
- Install the clamp [A] as near as possible to the hose end to clear the raised rib of the fitting. This will prevent the hoses from working loose.
- The clamp screws should be positioned correctly to prevent the clamps from contacting the other parts.

**Torque - Water Hose Clamp Screws: 2.0 N·m (0.20 kgf·m, 17 in·lb)**

#### **Hose Inspection**

- Refer to the Radiator Hose Damage and Installation Condition Inspection in the Periodic Maintenance chapter.

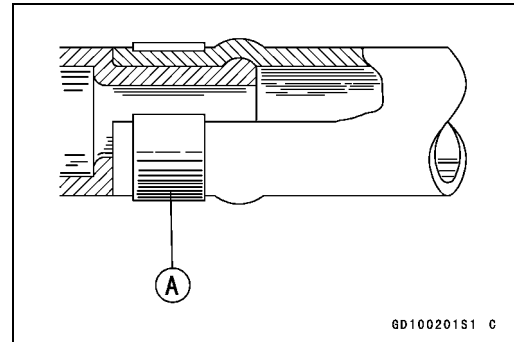

## **Water Temperature Sensor**

---

### ***Water Temperature Sensor Removal***

- Refer to the Water Temperature Sensor Removal in the Fuel System (DFI) chapter.

### ***Water Temperature Sensor Inspection***

- Refer to the Water Temperature Sensor Inspection in the Electrical System chapter.



# Engine Top End

## Table of Contents

Exploded View .....	5-2	Cylinder Head Removal .....	5-24
Exhaust System.....	5-6	Cylinder Head Installation .....	5-24
Specifications .....	5-8	Cylinder Head Warp.....	5-25
Special Tools and Sealant .....	5-9	Valves .....	5-26
Clean Air System.....	5-11	Valve Clearance Inspection .....	5-26
Air Suction Valve Removal.....	5-11	Valve Clearance Adjustment.....	5-26
Air Suction Valve Installation.....	5-11	Valve Removal .....	5-26
Air Suction Valve Inspection .....	5-11	Valve Installation .....	5-26
Air Switching Valve Removal .....	5-12	Valve Guide Removal .....	5-27
Air Switching Valve Installation ...	5-12	Valve Guide Installation .....	5-27
Air Switching Valve Operation		Valve-to-Guide Clearance	
Test.....	5-12	Measurement (Wobble	
Air Switching Valve Unit Test .....	5-12	Method) .....	5-28
Clean Air System Hose		Valve Seat Inspection .....	5-29
Inspection.....	5-12	Valve Seat Repair .....	5-29
Cylinder Head Cover .....	5-13	Throttle Body Assy Holder.....	5-34
Cylinder Head Cover Removal ....	5-13	Throttle Body Assy Holder	
Cylinder Head Cover Installation .	5-13	Removal .....	5-34
Camshaft Chain Tensioner .....	5-15	Throttle Body Assy Holder	
Camshaft Chain Tensioner		Installation .....	5-34
Removal .....	5-15	Muffler.....	5-35
Camshaft Chain Tensioner		Muffler Body Removal.....	5-35
Installation .....	5-15	Muffler Body Installation.....	5-36
Camshaft, Camshaft Chain .....	5-16	Rear Exhaust Pipe Removal.....	5-37
Camshaft Removal .....	5-16	Rear Exhaust Pipe Installation.....	5-38
Camshaft .....	5-18	Front Exhaust Pipe Removal .....	5-39
Camshaft Installation .....	5-18	Front Exhaust Pipe Installation ....	5-40
Camshaft, Camshaft Cap Wear ...	5-21	Exhaust Butterfly Valve Cable	
Camshaft Runout .....	5-22	Removal .....	5-41
Cam Wear .....	5-22	Exhaust Butterfly Valve Cable	
Camshaft Chain Removal .....	5-22	Installation .....	5-42
Cylinder Head.....	5-23		
Cylinder Compression			
Measurement .....	5-23		





**Exploded View**

No.	Fastener	Torque			Remarks
		N-m	kgf-m	ft-lb	
1	Air Suction Valve Cover Bolts	9.8	1.0	87 in-lb	L
2	Camshaft Cap Bolts	12	1.2	106 in-lb	S
3	Camshaft Chain Tensioner Cap Bolt	20	2.0	15	
4	Camshaft Chain Tensioner Mounting Bolts	11	1.1	97 in-lb	
5	Cam Sprocket Mounting Bolts	15	1.5	11	L
6	Water Passage Plugs	20	2.0	15	L
7	Cylinder Head Bolts (M9) (First)	15	1.5	11	MO, S
	Cylinder Head Bolts (M9) (Final)	39	4.0	29	MO, S
8	Cylinder Head Bolts (M6)	12	1.2	106 in-lb	S
9	Cylinder Head Cover Bolts	9.8	1.0	87 in-lb	
10	Front Camshaft Chain Guide Bolt (Lower)	12	1.2	106 in-lb	
11	Front Camshaft Chain Guide Bolt (Upper)	25	2.5	18	
12	Upper Camshaft Chain Guide Bolt	12	1.2	106 in-lb	
13	Spark Plugs	13	1.3	113 in-lb	
14	Throttle Body Assy Holder Clamp Bolts	2.9	0.30	26 in-lb	
15	Throttle Body Assy Holder Bolts	12	1.2	106 in-lb	L
16	Breather Hose Fitting	15	1.5	11	L

17. Apply engine oil to the #1 ~ #4 cam lobes around before the camshaft cap installation.

EO: Apply engine oil.

G: Apply grease.

HG: Apply high-temperature grease.

L: Apply a non-permanent locking agent.

M: Apply molybdenum disulfide grease.

MO: Apply molybdenum disulfide oil solution.

(mixture of the engine oil and molybdenum disulfide grease in a weight ratio 10 : 1)

R: Replacement Parts

S: Follow the specified tightening sequence.

SS: Apply silicone sealant.

# 5-4 ENGINE TOP END

## Exploded View

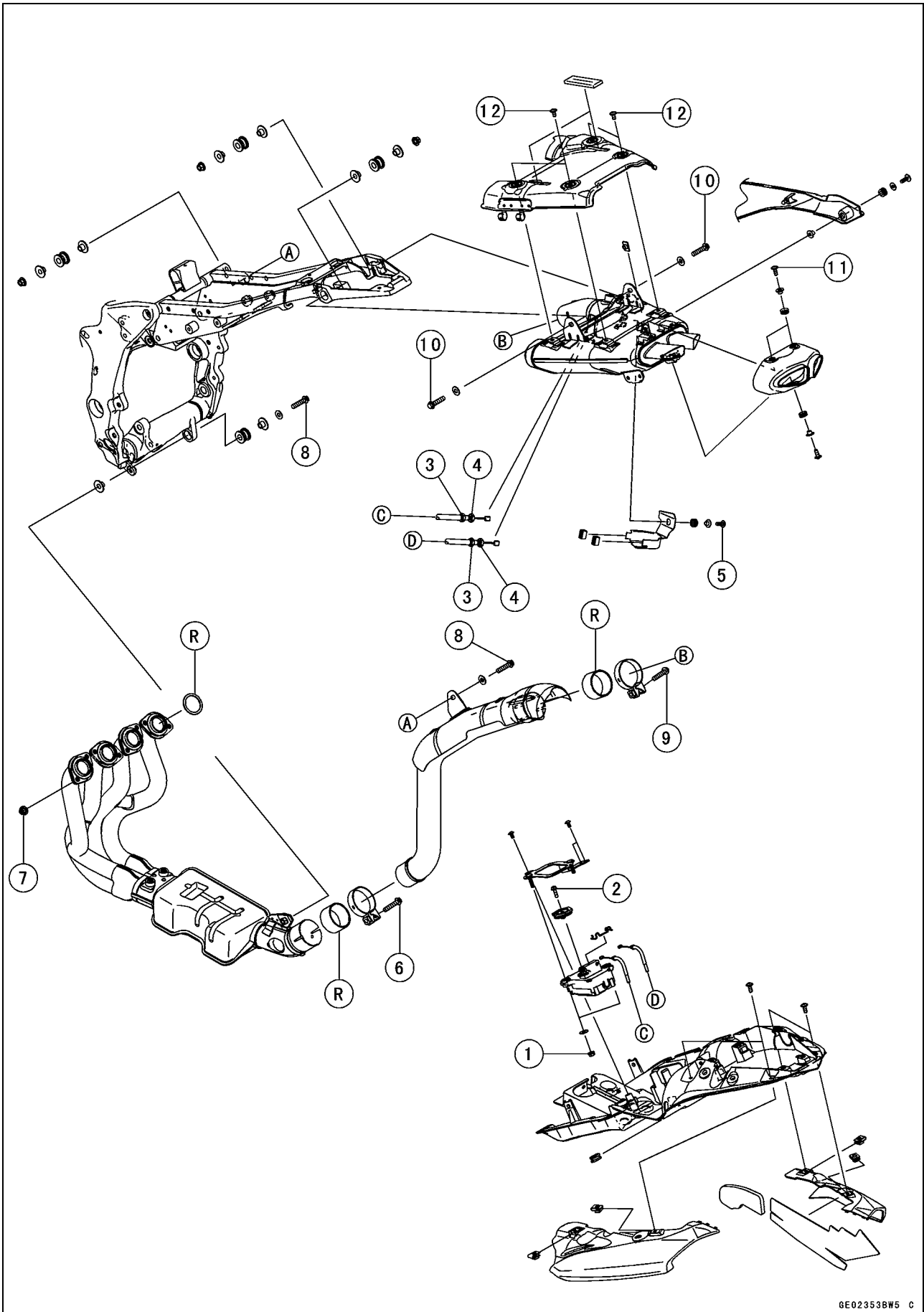

## Exploded View

No.	Fastener	Torque			Remarks
		N·m	kgf·m	ft·lb	
1	Exhaust Butterfly Valve Actuator Mounting Nuts	6.9	0.70	61 in·lb	
2	Exhaust Butterfly Valve Actuator Pulley Bolt	4.9	0.50	43 in·lb	
3	Exhaust Butterfly Valve Cable Adjuster Locknuts	6.9	0.70	61 in·lb	
4	Exhaust Butterfly Valve Cable Locknuts	6.9	0.70	61 in·lb	
5	Exhaust Butterfly Valve Cover Bolt	6.9	0.70	61 in·lb	
6	Exhaust Pipe Clamp Bolt	17	1.7	13	
7	Front Exhaust Pipe Holder Nuts	17	1.7	13	
8	Exhaust Pipe Mounting Bolts	28	2.8	21	
9	Muffler Body Clamp Bolt	17	1.7	12	
10	Muffler Body Mounting Bolts	28	2.8	21	
11	Muffler Body Rear Cover Bolts	6.9	0.70	61 in·lb	
12	Muffler Body Upper Cover Bolts	6.9	0.70	61 in·lb	

R: Replacement Parts

# 5-6 ENGINE TOP END

## Exhaust System

MANIFOLD	MUFFLER BODY	SPECIFICATION	MODEL
<b>Honeycomb Type Catalyst</b> <hr/> P/No. 39178-0068 Mark: KHI M 106	<b>Non-Catalyst</b> <hr/> P/No. 18091-0329 Mark: KHI K 510 EPA Noise Emission Control Information	WVTA (FULL H) GB WVTA (FULL H) WVTA (78.2 H)	ZX600P7F ~ ZX600P7F ~ ZX600P7F ~
<b>Honeycomb Type Catalyst</b> <hr/> P/No. 39178-0070 Mark: KHI M 107	<b>Non-Catalyst</b> <hr/> P/No. 18091-0329 Mark: KHI K 510 EPA Noise Emission Control Information	U.S.A CANADA AUSTRALIA	ZX600P7F ~ ZX600P7F ~ ZX600P7F ~
<b>Honeycomb Type Catalyst</b> <hr/> P/No. 39178-0075 Mark: KHI M 108	<b>Non-Catalyst</b> <hr/> P/No. 18091-0329 Mark: KHI K 510 EPA Noise Emission Control Information	U. S. A (CALIF)	ZX600P7FL ~
<b>Honeycomb Type Catalyst</b> <hr/> P/No. 39178-0078 Mark: KHI M 112	<b>Non-Catalyst</b> <hr/> P/No. 18091-0329 Mark: KHI K 510 EPA Noise Emission Control Information	MALAYSIA	ZX600P7F ~

GE24208B F

- WVTA (FULL H)      WVTA Model with Honeycomb Catalytic Converter (Full Power)
- GB WVTA (FULL H)      WVTA Model with Honeycomb Catalytic Converter (Left Side Traffic, Full Power)
- WVTA (78.2 H)      WVTA Model with Honeycomb Catalytic Converter (78.2 Kw Power)

Exhaust System

Manifold Mark Position [A]

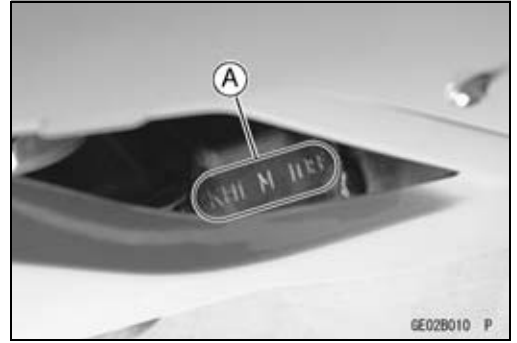

Muffler Body Mark Position [A]



- Manifold [A] with Holes [B] for Oxygen Sensors (Equipped Models).  
Oxygen Sensor #1 [C]  
Oxygen Sensor #2 [D]

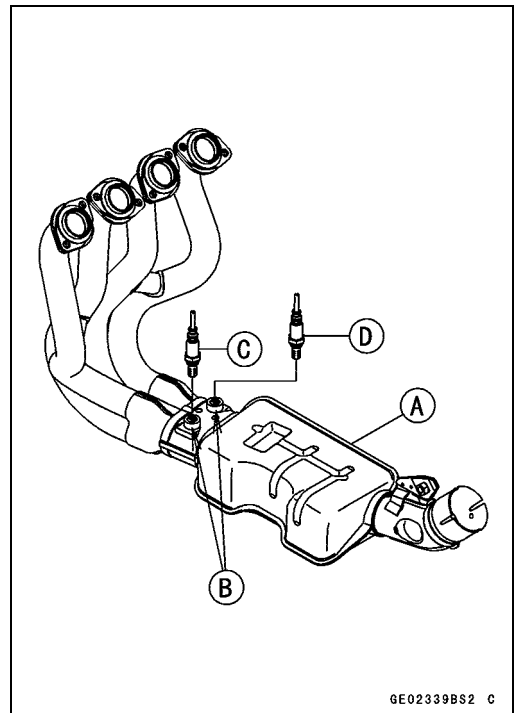

## 5-8 ENGINE TOP END

### Specifications

Item	Standard	Service Limit
<b>Camshafts</b>		
Cam Height:		
Exhaust	33.443 ~ 33.557 mm (1.3167 ~ 1.3211 in.)	33.34 mm (1.313 in.)
Inlet	34.243 ~ 34.357 mm (1.3481 ~ 1.3526 in.)	34.14 mm (1.344 in.)
Camshaft Journal/Camshaft Cap Clearance	0.038 ~ 0.081 mm (0.0015 ~ 0.0032 in.)	0.17 mm (0.0067 in.)
Camshaft Journal Diameter	23.940 ~ 23.962 mm (0.9425 ~ 0.9434 in.)	23.91 mm (0.941 in.)
Camshaft Bearing Inside Diameter	24.000 ~ 24.021 mm (0.9449 ~ 0.9457 in.)	24.08 mm (0.948 in.)
Camshaft Runout	TIR 0.02 mm (0.0008 in.) or less	TIR 0.1 mm (0.004 in.)
<b>Cylinder Head</b>		
Cylinder Compression	(Usable Range) 980 ~ 1 498 kPa (10.0 ~ 15.3 kgf/cm <sup>2</sup> , 142 ~ 217 psi) at 240 r/min (rpm)	— — —
Cylinder Head Warp	— — —	0.05 mm (0.002 in.)
<b>Valves</b>		
Valve Clearance:		
Exhaust	0.24 ~ 0.31 mm (0.0094 ~ 0.0122 in.)	— — —
Inlet	0.13 ~ 0.19 mm (0.0051 ~ 0.0075 in.)	— — —
Valve Head Thickness:		
Exhaust	1.0 mm (0.039 in.)	0.6 mm (0.024 in.)
Inlet	0.5 mm (0.020 in.)	0.25 mm (0.001 in.)
Valve Stem Bend	TIR 0.01 mm (0.0004 in.) or less	TIR 0.05 mm (0.002 in.)
Valve Stem Diameter:		
Exhaust	3.955 ~ 3.970 mm (0.1557 ~ 0.1563 in.)	3.94 mm (0.155 in.)
Inlet	3.975 ~ 3.990 mm (0.1565 ~ 0.1571 in.)	3.96 mm (0.156 in.)
Valve Guide Inside Diameter:		
Exhaust	4.000 ~ 4.012 mm (0.1575 ~ 0.1580 in.)	4.08 mm (0.161 in.)
Inlet	4.000 ~ 4.012 mm (0.1575 ~ 0.1580 in.)	4.08 mm (0.161 in.)
Valve/Valve Guide Clearance (Wobble Method):		
Exhaust	0.09 ~ 0.17 mm (0.0035 ~ 0.0067 in.)	0.38 mm (0.015 in.)
Inlet	0.03 ~ 0.10 mm (0.0012 ~ 0.0039 in.)	0.30 mm (0.012 in.)
Valve Seat Cutting Angle	32°, 45°, 60°	— — —
Valve Seating Surface:		
Width:		
Exhaust	0.8 ~ 1.2 mm (0.031 ~ 0.047 in.)	— — —
Inlet	0.5 ~ 1.0 mm (0.020 ~ 0.039 in.)	— — —
Outside Diameter:		
Exhaust	22.8 ~ 23.0 mm (0.898 ~ 0.906 in.)	— — —
Inlet	26.9 ~ 27.1 mm (1.059 ~ 1.067 in.)	— — —
Valve Spring Free Length:		
Exhaust	38.2 mm (1.504 in.)	37.1 mm (1.461 in.)
Inlet	39.2 mm (1.543 in.)	37.9 mm (1.492 in.)

Special Tools and Sealant

Compression Gauge, 20 kgf/cm<sup>2</sup>:  
57001-221

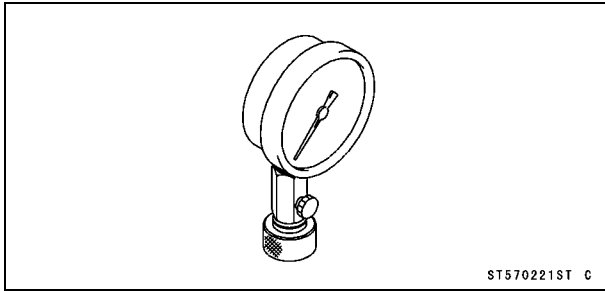

Valve Seat Cutter Holder Bar:  
57001-1128

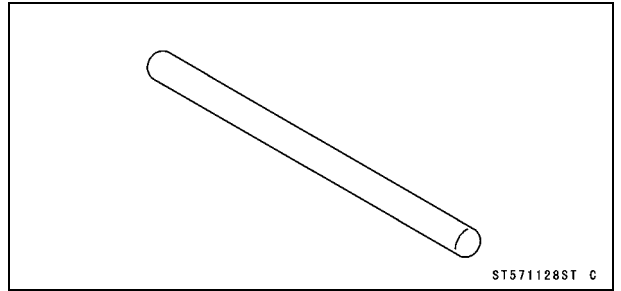

Valve Spring Compressor Assembly:  
57001-241

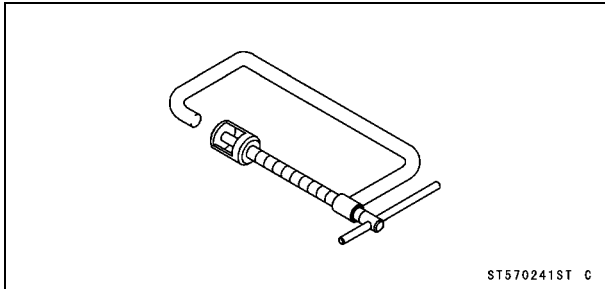

Valve Spring Compressor Adapter,  $\phi 20$ :  
57001-1154

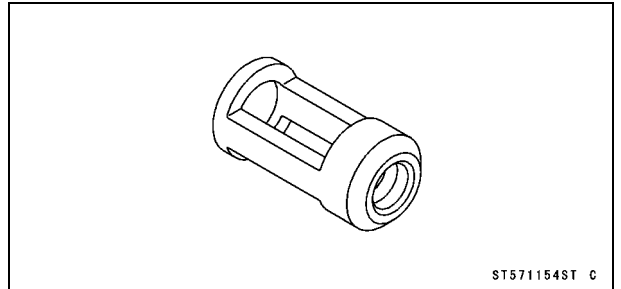

Valve Seat Cutter, 45° -  $\phi 24.5$ :  
57001-1113

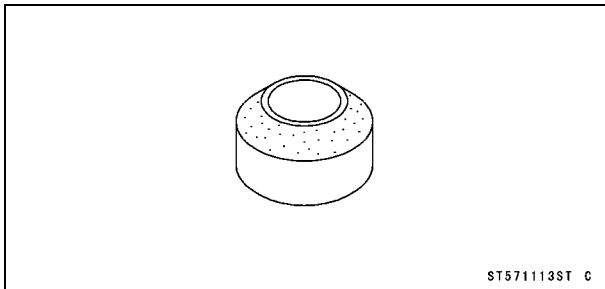

Valve Seat Cutter, 45° -  $\phi 30$ :  
57001-1187

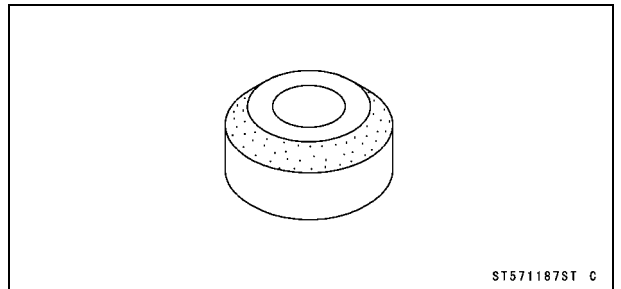

Valve Seat Cutter, 32° -  $\phi 25$ :  
57001-1118

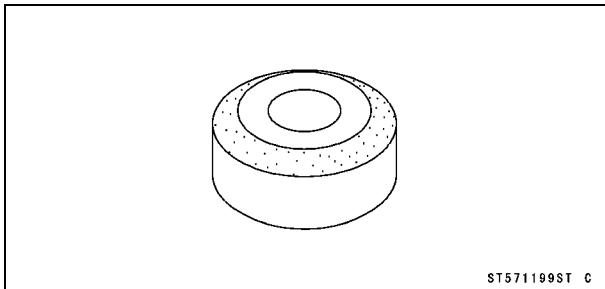

Valve Guide Arbor,  $\phi 4$ :  
57001-1273

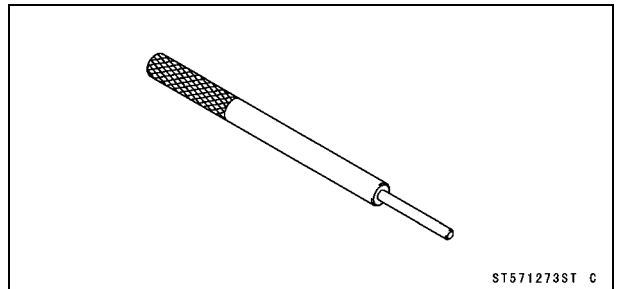

Valve Seat Cutter, 32° -  $\phi 30$ :  
57001-1120

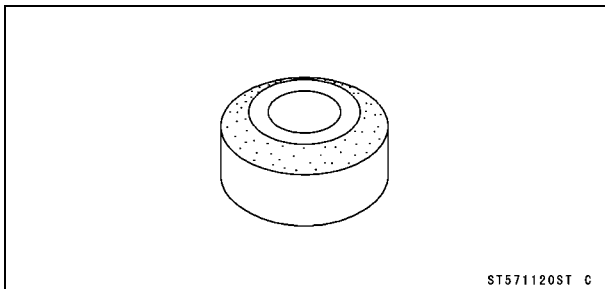

Valve Guide Reamer,  $\phi 4$ :  
57001-1274

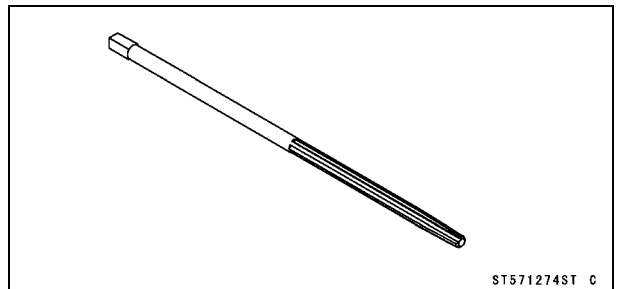

# 5-10 ENGINE TOP END

## Special Tools and Sealant

Valve Seat Cutter Holder,  $\phi 4$ :  
57001-1275

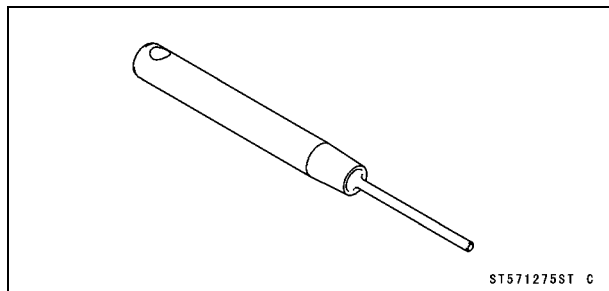

Valve Guide Driver:  
57001-1564

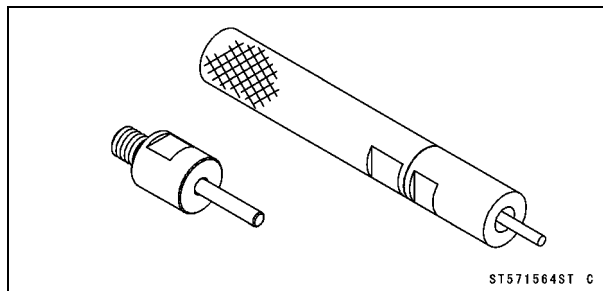

Compression Gauge Adapter, M10  $\times$  1.0:  
57001-1317

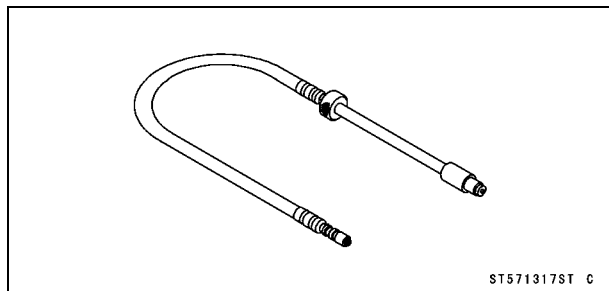

Valve Spring Compressor Adapter,  $\phi 24$ :  
57001-1586

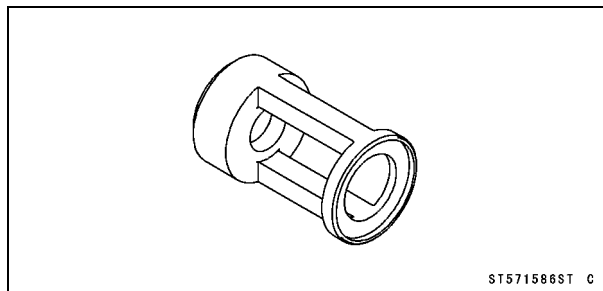

Valve Seat Cutter, 60° -  $\phi 25$ :  
57001-1328

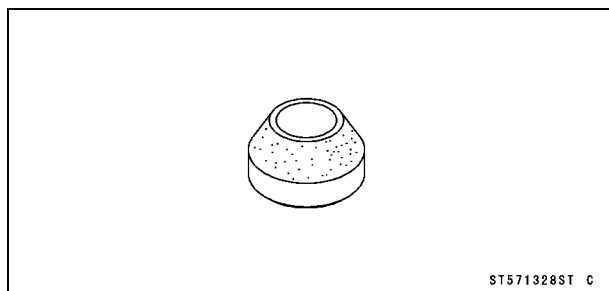

Attachment C:  
57001-1624

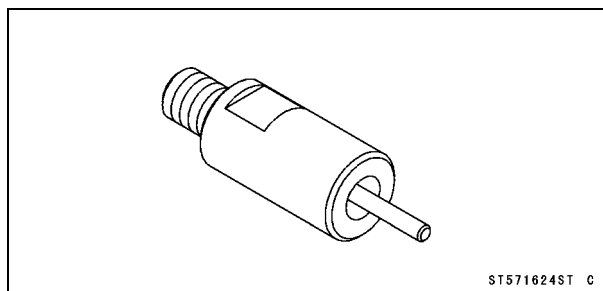

Valve Seat Cutter, 60° -  $\phi 27$ :  
57001-1409

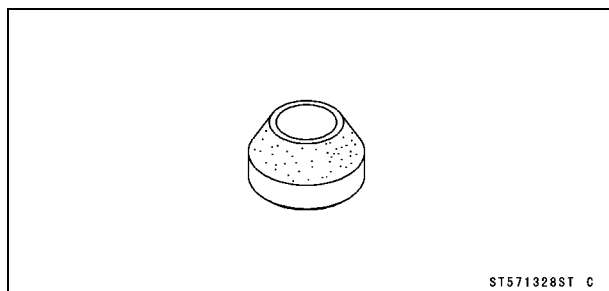

Kawasaki Bond (Silicone Sealant):  
92104-0004

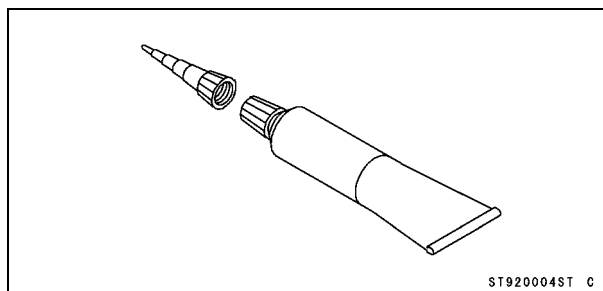



## Clean Air System

### Air Suction Valve Removal

- Remove:
  - Fuel Tank (see Fuel Tank Removal in the Fuel System (DFI) chapter)
  - Air Cleaner Housing (see Air Cleaner Housing Removal in the Fuel System (DFI) chapter)
- Separate the hoses [A] from the air suction valve cover.
- Remove:
  - Air Suction Valve Cover Bolts [B]
  - Air Suction Valve Cover [C]
  - Air Suction Valve

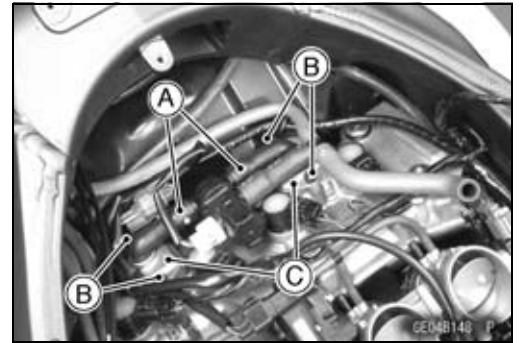

### Air Suction Valve Installation

- Install the air suction valve so that the openings [A] of the reeds face the rear and downward.

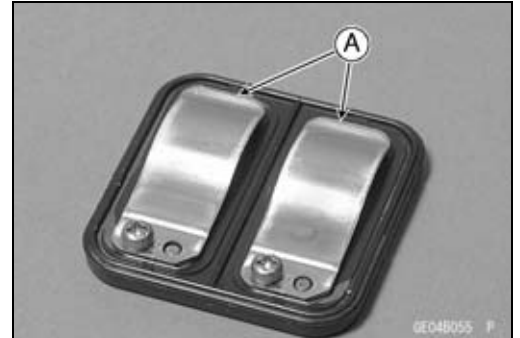

- Install the clamps [A] and bracket [B] as shown.
- Apply a non-permanent locking agent to the threads of the air suction valve cover bolts, and tighten them with the specified torque.

**Torque - Air Suction Valve Cover Bolts: 9.8 N·m (1.0 kgf·m, 87 in·lb)**

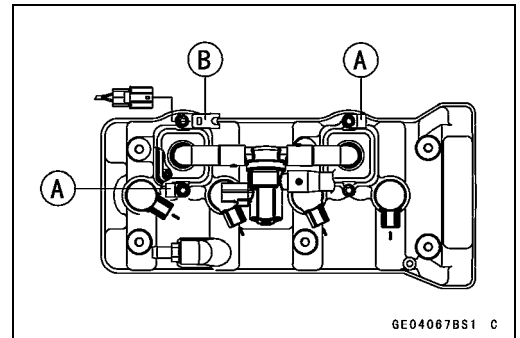

### Air Suction Valve Inspection

- Remove the air suction valve (see Air Suction Valve Removal in this chapter).
- Visually inspect the reeds [A] for cracks, folds, warps, heat damage, or other damage.
- ★ If there is any doubt as to the condition of the reed, replace the air suction valve as an assembly.
- Check the reed contact areas [B] of the valve holder for grooves, scratches, any signs of separation from the holder, or heat damage.
- ★ If there is any doubt as to the condition of the reed contact areas, replace the air suction valve as an assembly.
- ★ If any carbon or other foreign particles have accumulated between the reed and the reed contact area, wash the valve assembly with a high-flash point solvent.

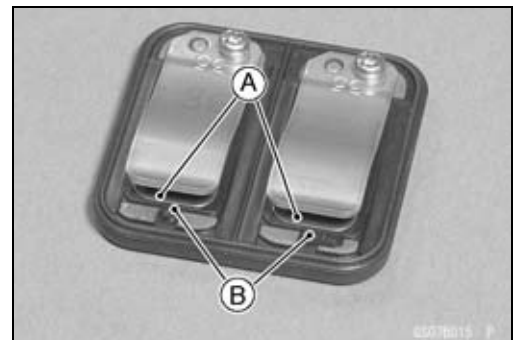

### CAUTION

**Do not scrape off the deposits with a scraper as this could damage the rubber, requiring replacement of the suction valve assembly.**

## 5-12 ENGINE TOP END

### Clean Air System

#### ***Air Switching Valve Removal***

- Remove:
  - Fuel Tank (see Fuel Tank Removal in the Fuel System (DFI) chapter)
  - Air Cleaner Housing (see Air Cleaner Housing Removal in the Fuel System (DFI) chapter)
- Disconnect the connector [A].
- Separate the hoses [B] from the air suction valve covers and air cleaner housing holder, and remove the air switching valve [C].

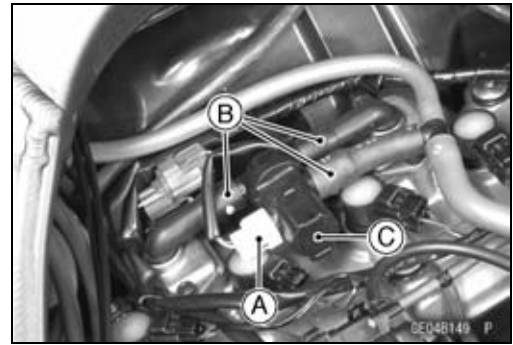

#### **CAUTION**

**Never drop the air switching valve, especially on a hard surface. Such a shock to the air switching valve can damage it.**

#### ***Air Switching Valve Installation***

- Route the hoses correctly (see Cable, Wire, and Hose Routing section in the Appendix chapter).

#### ***Air Switching Valve Operation Test***

- Refer to the Air Suction System Damage Inspection in the Periodic Maintenance chapter.

#### ***Air Switching Valve Unit Test***

- Refer to the Air Switching Valve Unit Test in the Electrical System chapter.

#### ***Clean Air System Hose Inspection***

- Be certain that all the hoses are routed without being flattened or kinked, and are connected correctly to the air cleaner housing, air switching valve and air suction valve covers.
- ★ If they are not, correct them. Replace them if they are damaged.

## Cylinder Head Cover

### Cylinder Head Cover Removal

- Remove:
  - Fuel Tank (see Fuel Tank Removal in the Fuel System (DFI) chapter)
  - Air Cleaner Housing (see Air Cleaner Housing Removal in the Fuel System (DFI) chapter)
  - Air Switching Valve (see Air Switching Valve Removal)
  - Throttle Body Assy (see Throttle Body Assy Removal in the Fuel System (DFI) chapter)
  - Stick Coils (see Stick Coil Removal in the Electrical System chapter)
- Remove:
  - Breather Hose
  - Cylinder Head Cover Ground Bolt [A]
  - Cylinder Head Cover Bolts [B]
  - Cylinder Head Cover [C]

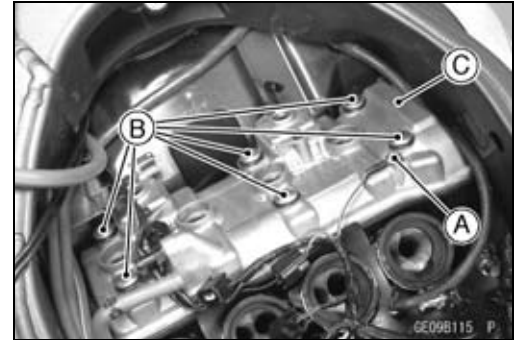

### Cylinder Head Cover Installation

- Replace the head cover gasket [A] with a new one.
- Apply silicone sealant [B] to the cylinder head as shown.  
**Sealant - Kawasaki Bond (Silicone Sealant): 92104-0004**

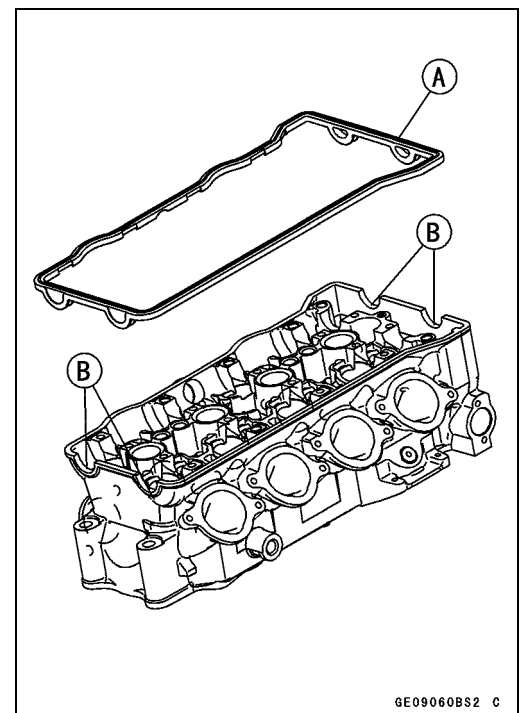

- Be sure to install the following parts.
  - Dowel Pins [A]
  - Plug Hole Gaskets [B]
- Install the gaskets so that the projections [C] face downward.

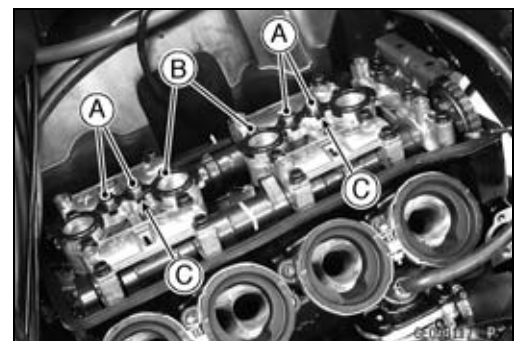

## 5-14 ENGINE TOP END

### Cylinder Head Cover

- Replace the washer [A] with new ones.
- Install the new washer with the metal side faces upward.

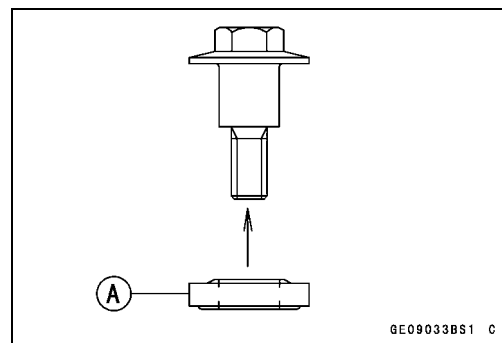

- Install the cylinder head cover.
- Tighten the cylinder head cover bolts [A].  
**Torque - Cylinder Head Cover Bolts: 9.8 N·m (1.0 kgf·m, 87 in·lb)**
- Install the ground terminal [B] and tighten the cylinder head cover ground bolt [C].
- When installing the breather hose fitting [D], apply a non-permanent locking agent to thread of the fitting and tighten it.  
**Torque - Breather Hose Fitting: 15 N·m (1.5 kgf·m, 11 ft·lb)**
- Install the removed parts (refer to appropriate chapters).

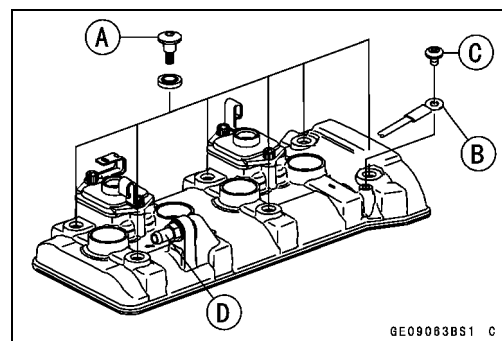

## Camshaft Chain Tensioner

### Camshaft Chain Tensioner Removal

#### CAUTION

This is a non-return type camshaft chain tensioner. The push rod does not return to its original position once it moves out to take up camshaft chain slack. Observe all the rules listed below:

When removing the tensioner, do not take out the mounting bolts only halfway. Retightening the mounting bolts from this position could damage the tensioner and the camshaft chain. Once the bolts are loosened, the tensioner must be removed and reset as described in "Camshaft Chain Tensioner Installation".

Do not turn over the crankshaft while the tensioner is removed. This could upset the camshaft chain timing, and damage the valves.

- Remove:
  - Right Middle Fairing (see Right Middle Fairing Removal in the Frame chapter)
  - Cap Bolt [A]
  - Washer [B]
  - Spring [C]
  - Rod [D]
- Remove the mounting bolts [E] and take off the camshaft chain tensioner.

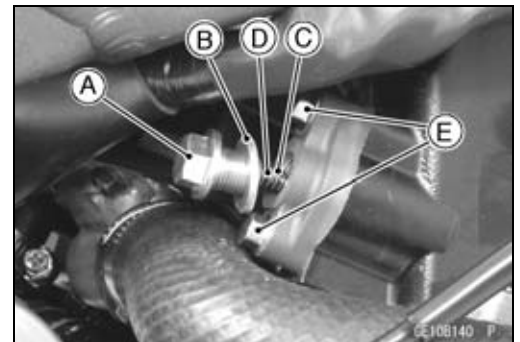

### Camshaft Chain Tensioner Installation

- Apply grease to the O-ring.
- Release the stopper [A] and push the push rod [B] into the interior of tensioner body [C].
- Install the tensioner body so that the stopper faces upward.

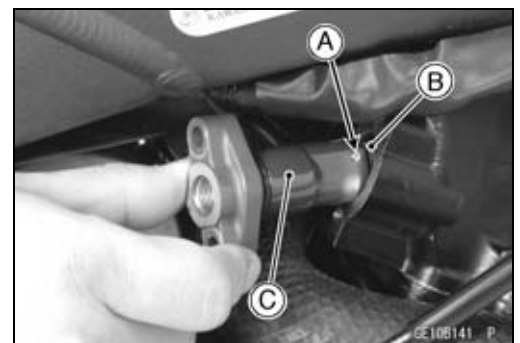

- Tighten the tensioner mounting bolts [A].
  - Torque - Camshaft Chain Tensioner Mounting Bolts: 11 N·m (1.1 kgf·m, 97 in·lb)**
- Install the rod, spring and washer.
- Tighten the cap bolt [B].
  - Torque - Camshaft Chain Tensioner Cap Bolt: 20 N·m (2.0 kgf·m, 15 ft·lb)**

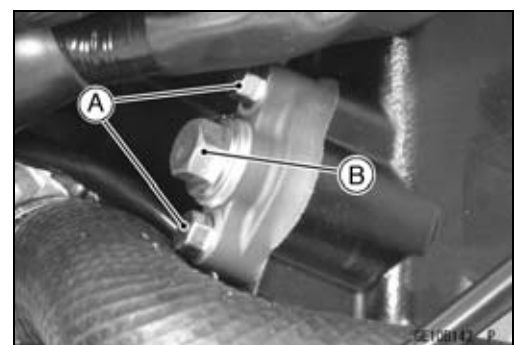

## 5-16 ENGINE TOP END

### Camshaft, Camshaft Chain

#### Camshaft Removal

- Remove the cylinder head cover (see Cylinder Head Cover Removal).
- Remove the timing inspection cap [A] and starter clutch bolt cap [B] on the starter clutch cover [C].

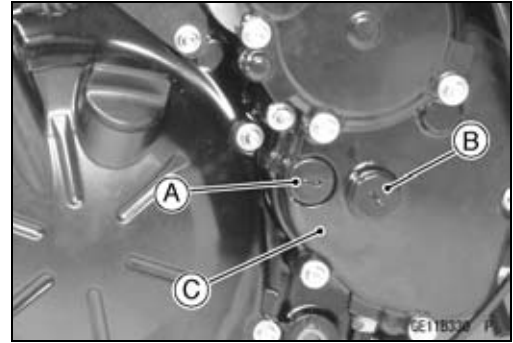

- Using a wrench on the starter clutch bolt [A], turn the crankshaft clockwise until the line [B] (TDC mark for #1,4 pistons) on the starter clutch is aligned with the notch [C] in the edge of the timing inspection hole [D] in the starter clutch cover.

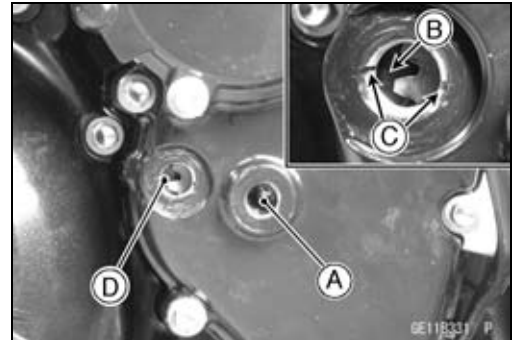

- ★ If the starter clutch cover is removed, perform the next procedure.

- Using a wrench on the starter clutch bolt [A], turn the crankshaft clockwise until the line [B] (TDC mark for #1,4 pistons) on the starter clutch [C] is aligned with the mating surface [D] of crankcase rear side.

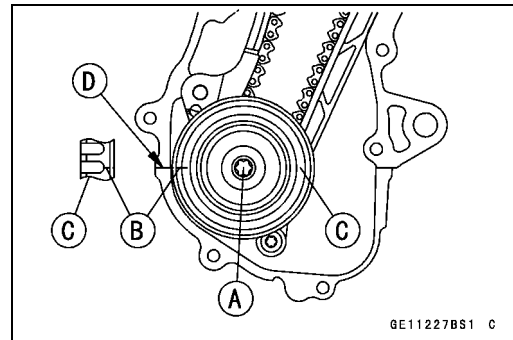

- Remove the camshaft chain tensioner (see Camshaft Chain Tensioner Removal).
- Loosen the upper chain guid bolts and camshaft cap bolts as shown sequence [1 ~ 20] in the figure, and remove them.
- Remove:
  - Upper Chain Guide [A]
  - Camshaft Caps [B]
  - Camshafts [C]
- Stuff a clean cloth into the chain tunnel to keep any parts from dropping into the crankcase.

Camshaft, Camshaft Chain

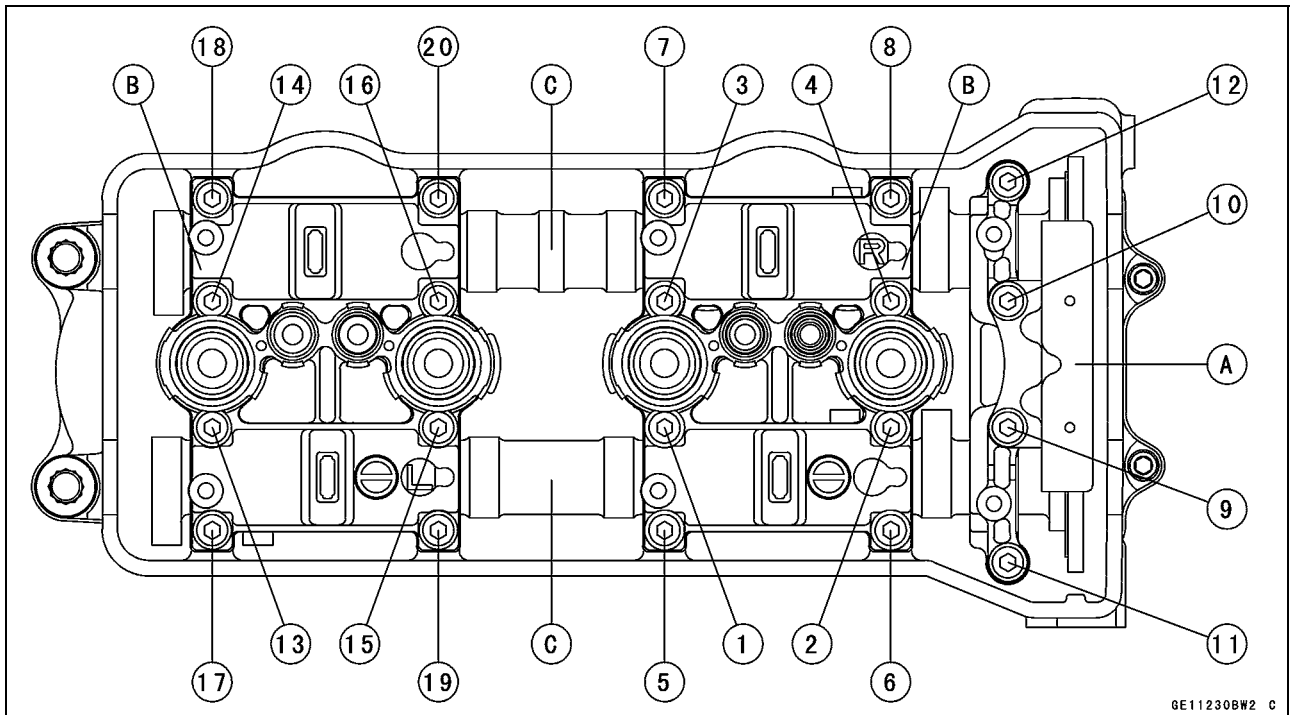

GE11230BW2 C

- Remove the cam sprocket mounting bolts [A].
- Remove the cam sprocket.

**CAUTION**

The crankshaft may be turned while the camshafts are removed. Always pull the chain taut while turning the crankshaft. This avoids kinking the chain on the lower (crankshaft) sprocket. A kinked chain could damage both the chain and the sprocket.

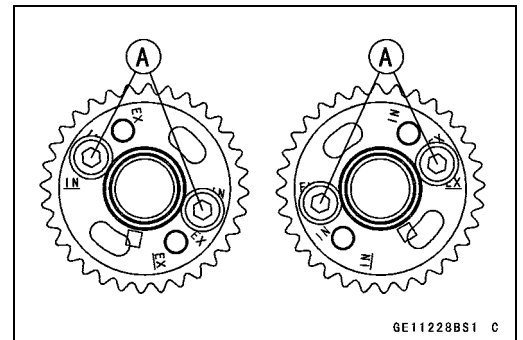

GE11228BS1 C

## 5-18 ENGINE TOP END

### Camshaft

#### Camshaft Installation

##### NOTE

- The exhaust camshaft has a 4516 EX mark [A] and the inlet camshaft has a 4516 IN mark [B]. Be careful not to mix up these shafts.

- Install the cam sprockets as shown in the figure.
  - #4 Cam Positions [A]
  - Inlet Cam Sprocket [B]
  - Exhaust Cam Sprocket [C]
- Apply a non-permanent locking agent to the threads and tighten the bolts.  
**Torque - Cam Sprocket Mounting Bolts: 15 N·m (1.5 kgf·m, 11 ft·lb)**

- Apply molybdenum disulfide oil solution [A]:  
All Journals and Tappets

- Using a wrench, turn the starter clutch bolt [A] counterclockwise until the line [B] (TDC mark for #1,4 pistons) on the starter clutch is aligned with the notches [C] in the edge of the timing inspection hole [D] in the starter clutch cover.

##### CAUTION

The crankshaft may be turned while the camshafts are removed. Always pull the chain taut while turning the crankshaft. This avoids kinking the chain on the lower (crankshaft) sprocket. A kinked chain could damage both the chain and the sprocket.

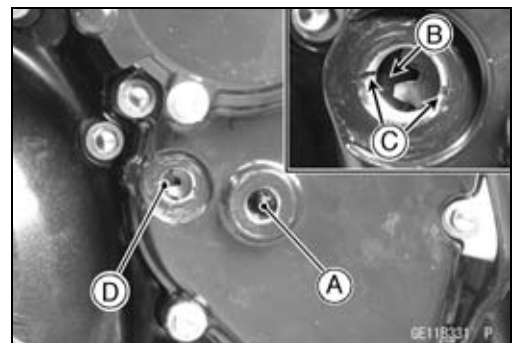
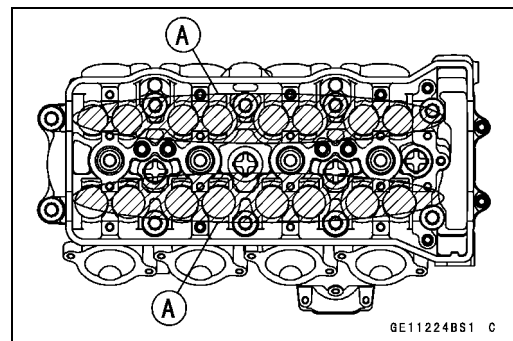
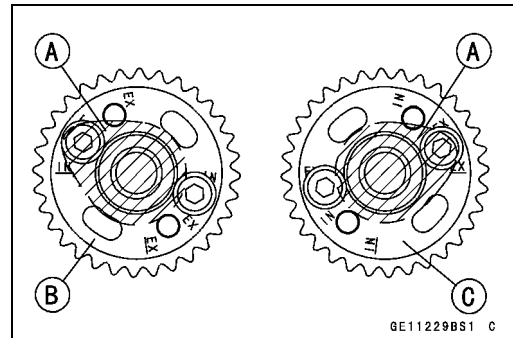
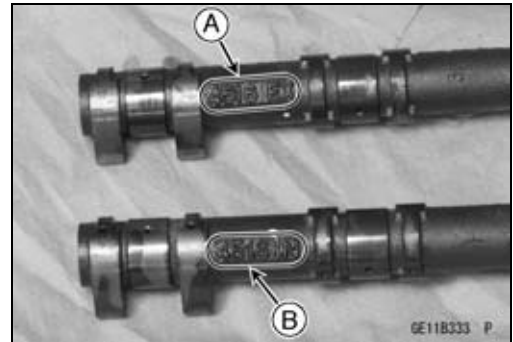



**Camshaft**

★If the starter clutch cover is removed, perform the next procedure.

○Using a wrench on the starter clutch bolt [A], turn the crankshaft clockwise until the line [B] (TDC mark for #1,4 pistons) on the starter clutch [C] is aligned with the mating surface [D] of crankcase rear side.

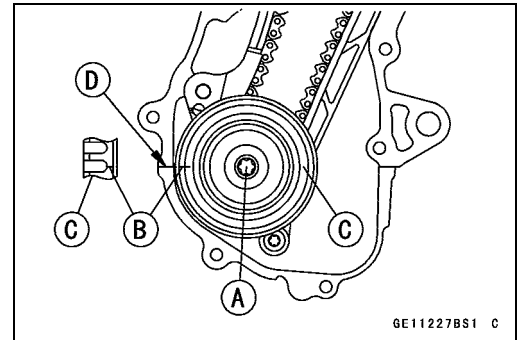

●Pull the tension side (exhaust side) [A] of the chain taut to install the chain.

●Engage the camshaft chain with the sprockets so that timing marks on the sprockets are positioned as shown.

○The timing marks must be aligned with the cylinder head upper surface [B].

EX Timing Mark [C]

IN Timing Mark [D]

#1 Pin [E]

#2 Pin [F]

#26 Pin [G]

#27 Pin [H]

○The below illustration is viewed from the right side of the engine when the engine removed.

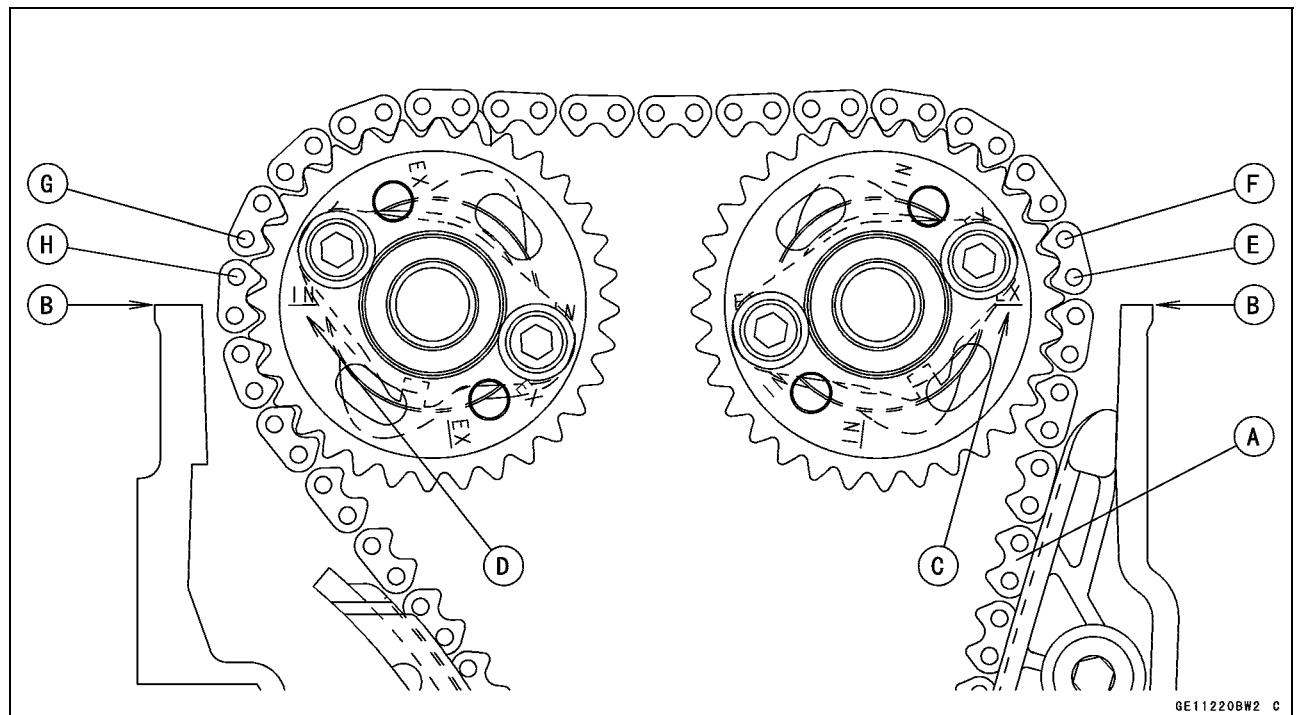
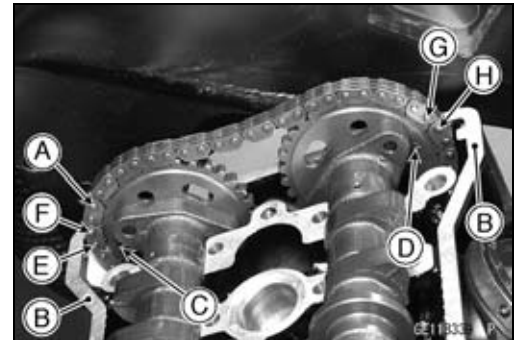

# 5-20 ENGINE TOP END

## Camshaft

- Apply molybdenum disulfide oil solution [A]:  
All Cam Lobes, Journals and Thrust Journals
- Apply engine oil [B]:  
#1 ~ #4 Cam Lobes of EX and IN Camshafts

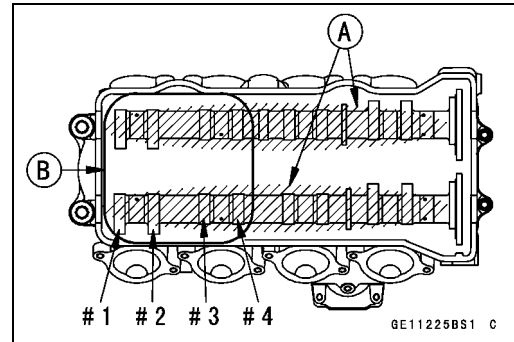

- Install:  
O-rings [A]  
Dowel Pins [B]  
O-rings [C]  
Dowel Pins [D]

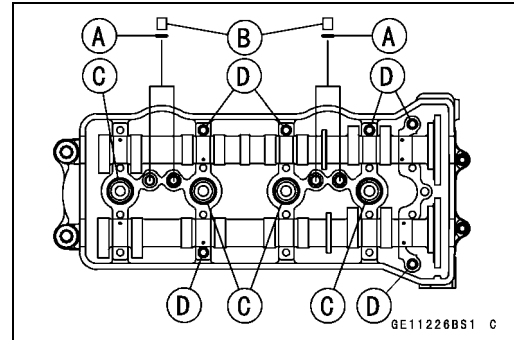

- Install the camshaft caps and upper camshaft chain guide [A] as shown.  
“R” Mark [B]  
“L” Mark [C]
- First tighten the all camshaft cap bolts evenly to seat the camshaft in place, then tighten all bolts following the specified tightening sequence.

### Torque- Camshaft Cap Bolts (1 ~ 20)

First: 5.9 N·m (0.6 kgf·m, 52 in·lb)

Final: 12 N·m (1.2 kgf·m, 106 in·lb)

### Upper Camshaft Chain Guide Bolts

First: 5.9 N·m (0.6 kgf·m, 52 in·lb)

Final: 12 N·m (1.2 kgf·m, 106 in·lb)

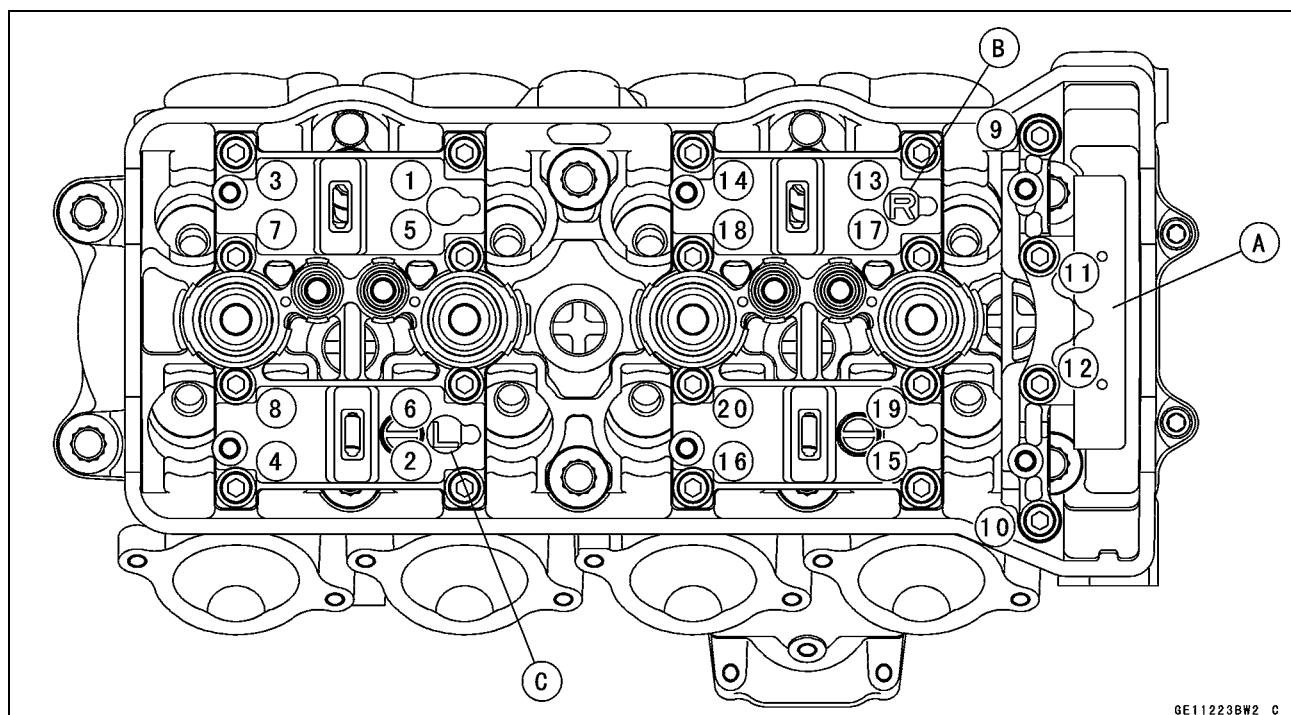

## Camshaft

- Install the camshaft chain tensioner (see Camshaft Chain Tensioner Installation).
- Turn the crankshaft 2 turns clockwise to allow the tensioner to expand and recheck the camshaft chain timing.
- Check the valve clearance (see Valve Clearance Inspection in the Periodic Maintenance chapter).
- Fill the following oil pockets with engine oil.
  - [A] Oil Pockets of Inlet Camshaft
  - [B] Oil Pockets of Exhaust Camshaft

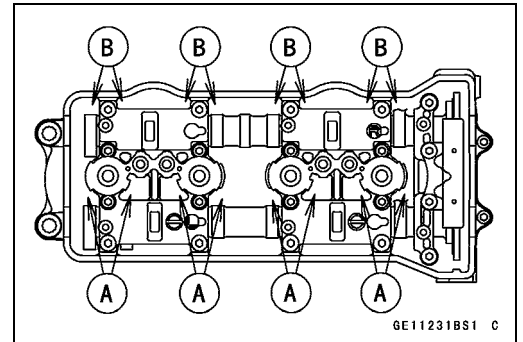

- Replace the O-ring of the timing inspection cap and starter clutch bolt cap.
- Apply grease to the new O-rings.
- Install the timing inspection cap and starter clutch bolt cap.

**Torque - Timing Inspection Cap: Hand-tighten**  
**Starter Clutch Bolt Cap: Hand-tighten**

- Install the cylinder head cover.

### NOTE

○ If the oil pump was removed, refer to the Oil Pump Installation in the Engine Lubrication System chapter.

### Camshaft, Camshaft Cap Wear

- Remove:
  - Camshaft Cap (see Camshaft Removal in this chapter)
- Cut strips of plastigage to journal width. Place a strip on each journal parallel to the camshaft installed in the correct position.
- Measure each clearance between the camshaft journal and the camshaft cap using plastigage (press gauge) [A].

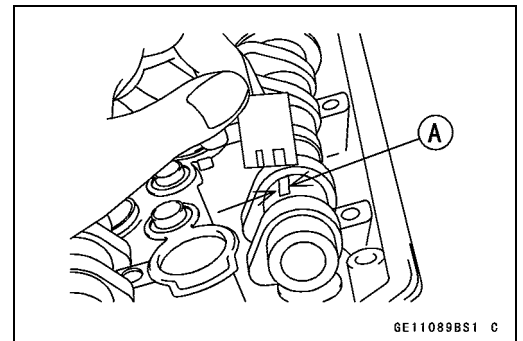

- Tighten (see Camshaft Installation):

**Torque - Camshaft Cap Bolts: 12 N·m (1.2 kgf·m, 106 in·lb)**

### NOTE

○ Do not turn the camshaft when the plastigage is between the journal and camshaft cap.

### Camshaft Journal, Camshaft Cap Clearance

**Standard: 0.038 ~ 0.081 mm (0.0015 ~ 0.0032 in.)**

**Service Limit: 0.17 mm (0.0067 in.)**

## 5-22 ENGINE TOP END

### Camshaft

- ★ If any clearance exceeds the service limit, measure the diameter of each camshaft journal with a micrometer.

#### Camshaft Journal Diameter

**Standard:** 23.940 ~ 23.962 mm (0.9425 ~ 0.9434 in.)

**Service Limit:** 23.91 mm (0.941 in.)

- ★ If the camshaft journal diameter is less than the service limit, replace the camshaft with a new one and measure the clearance again.
- ★ If the clearance still remains out of the limit, replace the cylinder head unit.

#### Camshaft Runout

- Remove the camshaft (see Camshaft Removal).
- Set the camshaft in a camshaft alignment jig or on V blocks.
- Measure runout with a dial gauge at the specified place as shown.
- ★ If the runout exceeds the service limit, replace the shaft.

#### Camshaft Runout

**Standard:** TIR 0.02 mm (0.0008 in.) or less

**Service Limit:** TIR 0.1 mm (0.004 in.)

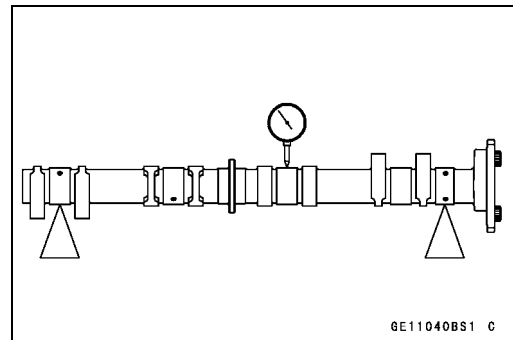

#### Cam Wear

- Remove the camshaft (see Camshaft Removal).
- Measure the height [A] of each cam with a micrometer.
- ★ If the cams are worn down past the service limit, replace the camshaft.

#### Cam Height

##### Standard:

**Exhaust** 33.443 ~ 33.557 mm (1.3167 ~ 1.3211 in.)

**Inlet** 34.243 ~ 34.357 mm (1.3481 ~ 1.3526 in.)

##### Service Limit:

**Exhaust** 33.34 mm (1.313 in.)

**Inlet** 34.14 mm (1.344 in.)

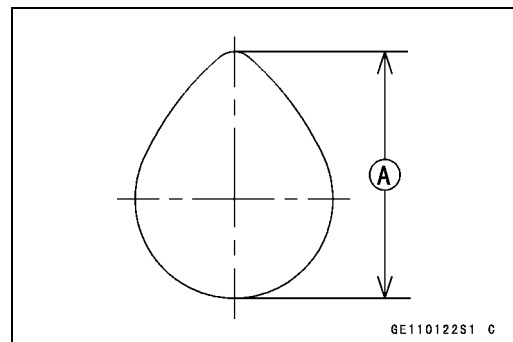

#### Camshaft Chain Removal

- Split the crankcase (see Crankcase Splitting in the Crankshaft/Transmission chapter).
- Remove the camshaft chain [A] from the crankshaft sprocket.

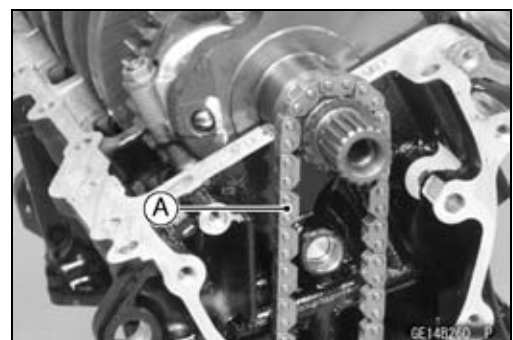

**Cylinder Head**

**Cylinder Compression Measurement**

**NOTE**

○ Use the battery which is fully charged.

- Warm up the engine thoroughly.
- Stop the engine.
- Remove:
  - Fuel Tank (see Fuel Tank Removal in the Fuel System (DFI) chapter)
  - Air Cleaner Housing (see Air Cleaner Housing Removal in the Fuel System (DFI) chapter)
  - Stick Coils (see Stick Coil (Ignition Coil together with Spark Plug Cap) Removal in the Electrical System chapter)
  - Spark Plugs (see Spark Plug Removal in the Electrical System chapter)
- Attach the compression gauge [A] and adapter [B] firmly into the spark plug hole.
- Using the starter motor, turn the engine over with the throttle fully open until the compression gauge stops rising; the compression is the highest reading obtainable.

**Special Tools - Compression Gauge, 20 kgf/cm<sup>2</sup> [A]: 57001-221**

**Compression Gauge Adapter, M10 × 1.0 [B]: 57001-1317**

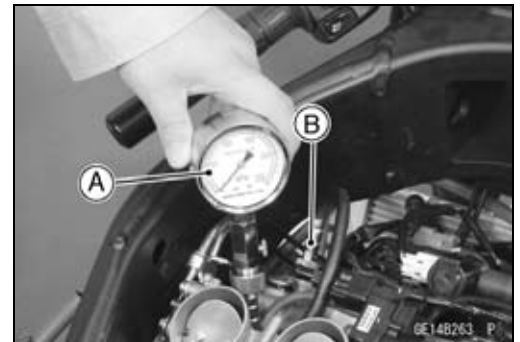

**Cylinder Compression**

**Usable Range: 980 ~ 1 498 kPa (10.0 ~ 15.3 kgf/cm<sup>2</sup>, 142 ~ 217 psi) at 240 r/min (rpm)**

- Repeat the measurement for the other cylinders.
- Install the spark plugs.

**Torque - Spark Plugs: 13 N·m (1.3 kgf·m, 113 in·lb)**

○ The following table should be consulted if the obtainable compression reading is not within the usable range.

<b>Problem</b>	<b>Diagnosis</b>	<b>Remedy (Action)</b>
Cylinder compression is higher than usable range	Carbon accumulation on piston and in combustion chamber possibly due to damaged valve stem oil seal and/or damaged piston oil rings (This may be indicated by white exhaust smoke).	Remove the carbon deposits and replace damaged parts if necessary.
	Incorrect cylinder head gasket thickness	Replace the gasket with a standard part.
Cylinder compression is lower than usable range	Gas leakage around cylinder head	Replace damaged check gasket and cylinder head warp.
	Bad condition of valve seating	Repair if necessary.
	Incorrect valve clearance	Adjust the valve clearance.
	Incorrect piston/cylinder clearance	Replace the piston and/or cylinder.
	Piston seizure	Inspect the cylinder and replace/repair the cylinder and/or piston as necessary.
	Bad condition of piston ring and/or piston ring grooves.	Replace the piston and/or the piston rings.

## 5-24 ENGINE TOP END

### Cylinder Head

#### Cylinder Head Removal

- Drain:
  - Coolant (see Coolant Change in the Periodic Maintenance chapter)
  - Engine Oil (see Engine Oil Change in the Periodic Maintenance chapter)
- Remove:
  - Engine (see Engine Removal in the Engine Removal/Installation chapter)
  - Cylinder Head Cover (see Cylinder Head Cover Removal)
  - Camshafts (see Camshaft Removal)
- Remove the front camshaft chain guide bolt (upper) [A].

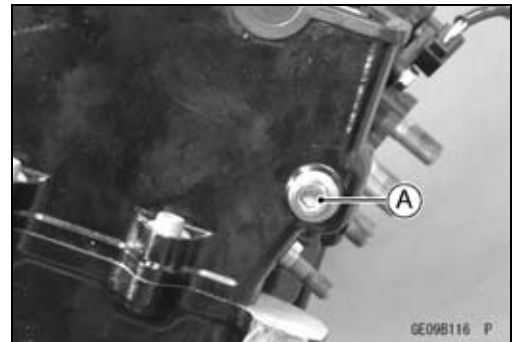

- Loosen the M6 and M9 cylinder head bolts as shown sequence [1 ~ 12] in the figure, and remove them.
- Take off the cylinder head to upward.

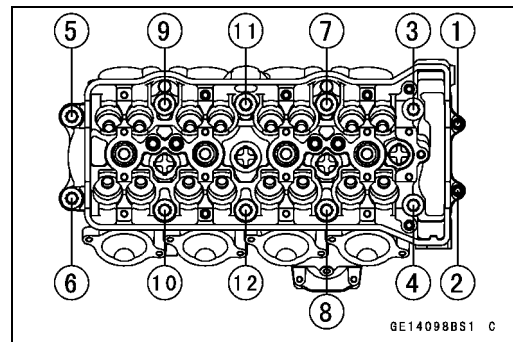

#### Cylinder Head Installation

##### NOTE

○The camshaft cap is machined with the cylinder head, so if a new cylinder head is installed, use the cap that is supplied with the new head.

- Install a new cylinder head gasket and dowel pins.
- Apply molybdenum disulfide oil solution to both sides [A] of the washers and threads [B] of M9 bolts [C].

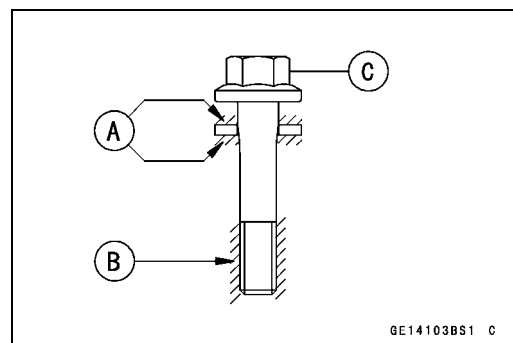

## Cylinder Head

- Tighten the M9 cylinder head bolts following the tightening sequence [1 ~ 10].

**Torque - Cylinder Head Bolts (M9):**

First: 15 N·m (1.5 kgf·m, 11 ft·lb)

Final: 39 N·m (4.0 kgf·m, 29 ft·lb)

- Tighten the M6 cylinder head bolts [11,12].

**Torque - Cylinder Head Bolts (M6): 12 N·m (1.2 kgf·m, 106 in·lb)**

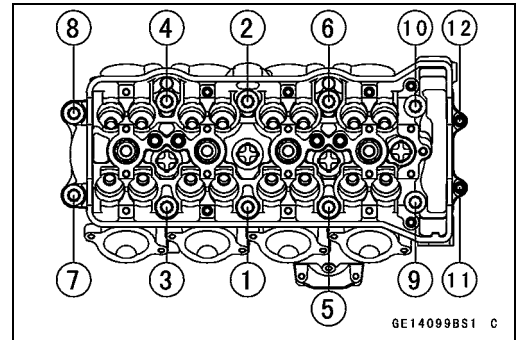

- Install:

Front Camshaft Chain Guide Bolt [A]

O-ring [B]

- Apply grease to the new O-ring.

- Tighten:

**Torque - Front Camshaft Chain Guide Bolt (Upper): 25 N·m (2.5 kgf·m, 18 ft·lb)**

- Install the removed parts (see appropriate chapters).

**NOTE**

- If the oil pump was removed, refer to the Oil Pump Installation in the Engine Lubrication System chapter.

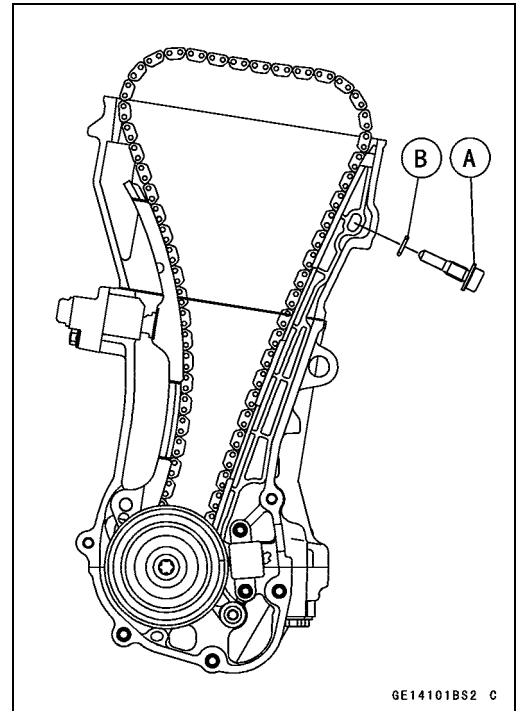

### Cylinder Head Warp

- Clean the cylinder head.
- Lay a straightedge across the lower surface of the cylinder head at several positions.
- Use a thickness gauge [A] to measure the space between the straightedge [B] and the head.

**Cylinder Head Warp**

Standard: ---

Service Limit: 0.05 mm (0.002 in.)

- ★ If the cylinder head is warped more than the service limit, replace it.
- ★ If the cylinder head is warped less than the service limit, repair the head by rubbing the lower surface on emery paper secured to a surface plate (first No. 200, then No. 400).

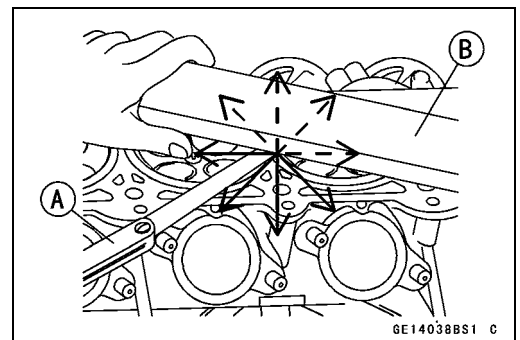

## 5-26 ENGINE TOP END

### Valves

#### Valve Clearance Inspection

- Refer to the Valve Clearance Inspection in the Periodic Maintenance chapter.

#### Valve Clearance Adjustment

- Refer to the Valve Clearance Adjustment in the Periodic Maintenance chapter.

#### Valve Removal

- Remove the cylinder head (see Cylinder Head Removal).
- Remove the valve lifter and shim.
- Mark and record the valve lifter and shim locations so they can be installed in their original positions.
- Using the valve spring compressor assembly, remove the valve.

- Special Tools - Valve Spring Compressor Assembly [A]:**  
57001-241  
**Valve Spring Compressor Adapter,  $\phi$ 20 [B]:**  
57001-1154 (EX)  
**Valve Spring Compressor Adapter,  $\phi$ 24 [B]:**  
57001-1586 (IN)

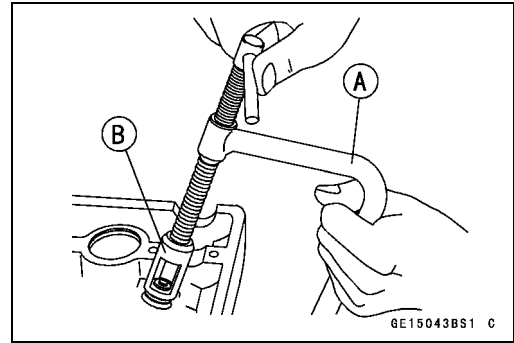

#### Valve Installation

- Replace the oil seal with a new one.
- Apply a thin coat of molybdenum disulfide grease to the valve stem before valve installation.
- Install the springs so that the closed coil end faces downwards.

Valve Stem [A]

Oil Seal [B]

Spring Seat [C]

Exhaust- $\phi$ 22.1 mm (0.87 in.)

Inlet- $\phi$ 23.5 mm (0.93 in.)

Closed Coil End [D]

Valve Spring [E]:

Exhaust-Yellow Paint

Inlet-White Paint

Retainer [F]

Split Keepers [G]

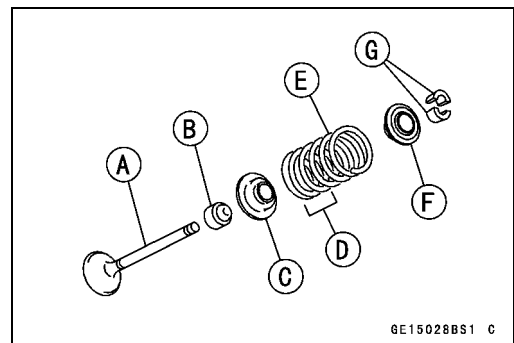

- After installing the valve, tap the all retainers [A] and valve stem ends lightly for the split keepers fitting surely.
- First tap the top [B] of the retainer and then tap the valve stem end [C].

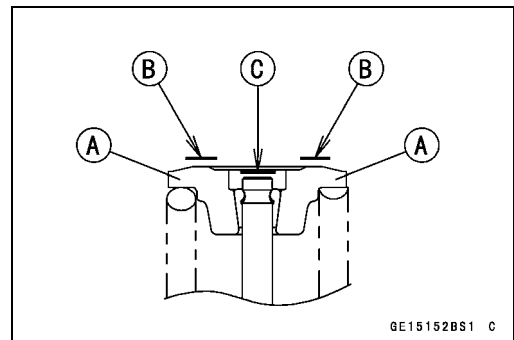



## Valves

### Valve Guide Removal

- Remove:
  - Valve (see Valve Removal)
  - Oil Seal
  - Spring Seat
- Heat the area around the valve guide to 120 ~ 150°C (248 ~ 302°F), and hammer lightly on the valve guide arbor [A] to remove the guide from the top of the head.

#### CAUTION

**Do not heat the cylinder head with a torch. This will warp the cylinder head. Soak the cylinder head in oil and heat the oil.**

**Special Tool - Valve Guide Arbor,  $\phi$ 4: 57001-1273**

### Valve Guide Installation

- Apply engine oil to the valve guide outer surface before installation.
- Heat the area around the valve guide hole to about 120 ~ 150°C (248 ~ 302°F).

#### CAUTION

**Do not heat the cylinder head with a torch. This will warp the cylinder head. Soak the cylinder head and heat the oil.**

- Using the valve guide driver and attachment [A], press and insert the valve guide in until the attachment surface [B] touches the head surface [C].  
13.3 ~ 13.5 mm (0.52 ~ 0.53 in.) [D]

**Special Tools - Valve Guide Driver: 57001-1564  
Attachment C: 57001-1624**

- Ream the valve guide with valve guide reamer [A], even if the old guide is reused.

**Special Tool - Valve Guide Reamer,  $\phi$ 4: 57001-1274**

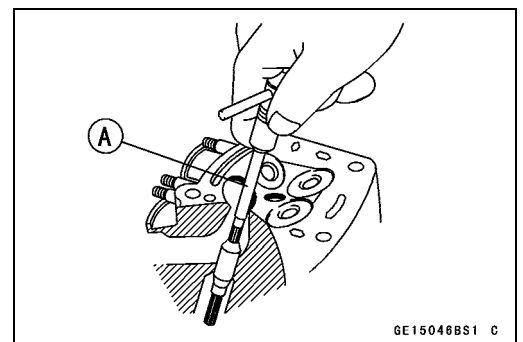
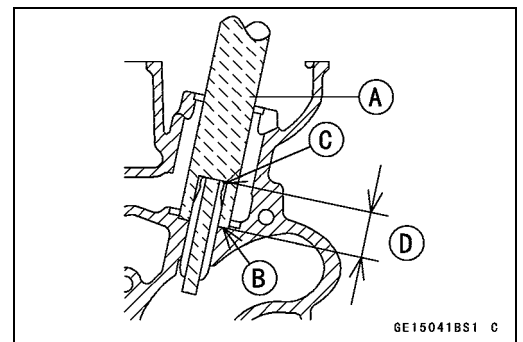
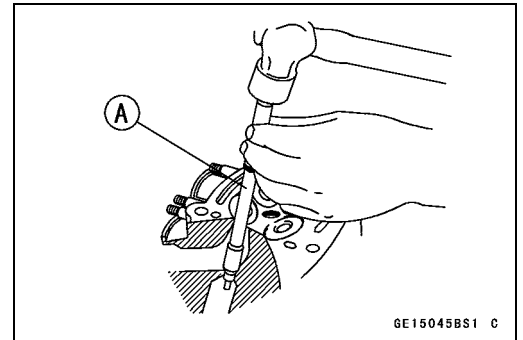

## 5-28 ENGINE TOP END

### Valves

#### Valve-to-Guide Clearance Measurement (Wobble Method)

If a small bore gauge is not available, inspect the valve guide wear by measuring the valve to valve guide clearance with the wobble method as indicated below.

- Insert a new valve [A] into the guide [B] and set a dial gauge against the stem perpendicular to it as close as possible to the cylinder head mating surface.
- Move the stem back and forth [C] to measure valve/valve guide clearance.
- Repeat the measurement in a direction at a right angle to the first.
- ★ If the reading exceeds the service limit, replace the guide.

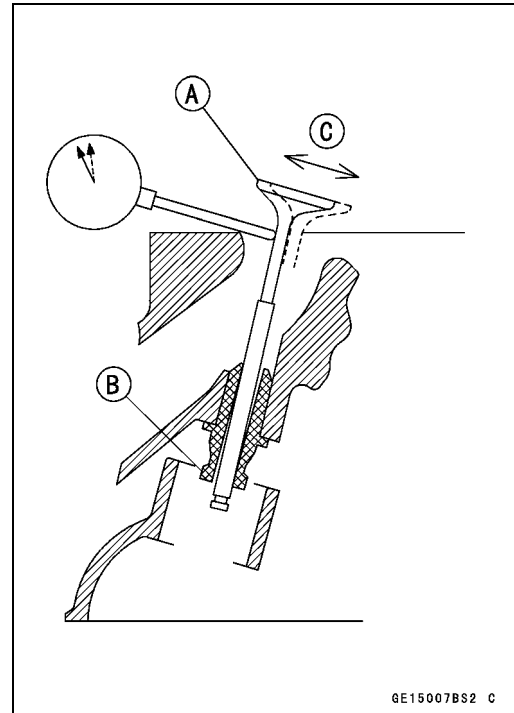

#### NOTE

- The reading is not actual valve/valve guide clearance because the measuring point is above the guide.

#### Valve/Valve Guide Clearance (Wobble Method)

##### Standard:

Exhaust	0.09 ~ 0.17 mm (0.0035 ~ 0.0067 in.)
Inlet	0.03 ~ 0.10 mm (0.0012 ~ 0.0039 in.)

##### Service Limit:

Exhaust	0.38 mm (0.015 in.)
Inlet	0.30 mm (0.012 in.)

## Valves

### Valve Seat Inspection

- Remove the valve (see Valve Removal in this chapter).
- Check the valve seating surface [A] between the valve [B] and valve seat [C].
- Measure the outside diameter [D] of the seating pattern on the valve seat.
- ★ If the outside diameter is too large or too small, repair the seat (see Valve Seat Repair in this chapter).

#### Valve Seating Surface Outside Diameter

##### Standard:

Exhaust 22.8 ~ 23.0 mm (0.898 ~ 0.906 in.)

Inlet 26.9 ~ 27.1 mm (1.059 ~ 1.067 in.)

- Measure the seat width [E] of the portion where there is no build-up carbon (white portion) of the valve seat with a vernier caliper.

Good [F]

- ★ If the width is too wide [G], too narrow [H] or uneven [J], repair the seat (see Valve Seat Repair in this chapter).

#### Valve Seating Surface Width

##### Standard:

Exhaust 0.8 ~ 1.2 mm (0.031 ~ 0.047 in.)

Inlet 0.5 ~ 1.0 mm (0.020 ~ 0.039 in.)

### Valve Seat Repair

- Repair the valve seat with the valve seat cutters [A].

Special Tools - Valve Seat Cutter Holder Bar [C]: 57001-1128

Valve Seat Cutter Holder,  $\phi$ 4 [B]: 57001-1275

#### For Exhaust Valve Seat

Valve Seat Cutter, 45° -  $\phi$ 24.5: 57001-1113

Valve Seat Cutter, 32° -  $\phi$ 25: 57001-1118

Valve Seat Cutter, 60° -  $\phi$ 25: 57001-1328

#### For Inlet Valve Seat

Valve Seat Cutter, 45° -  $\phi$ 30: 57001-1187

Valve Seat Cutter, 32° -  $\phi$ 30: 57001-1120

Valve Seat Cutter, 60° -  $\phi$ 27: 57001-1409

- ★ If the manufacturer's instructions are not available, use the following procedure.

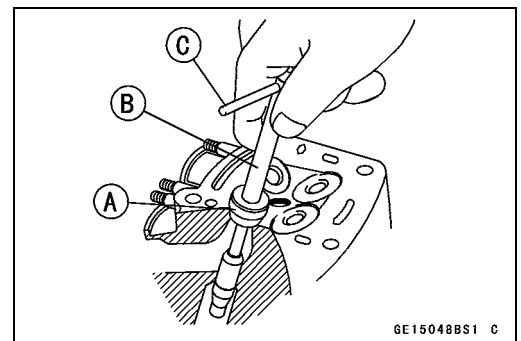
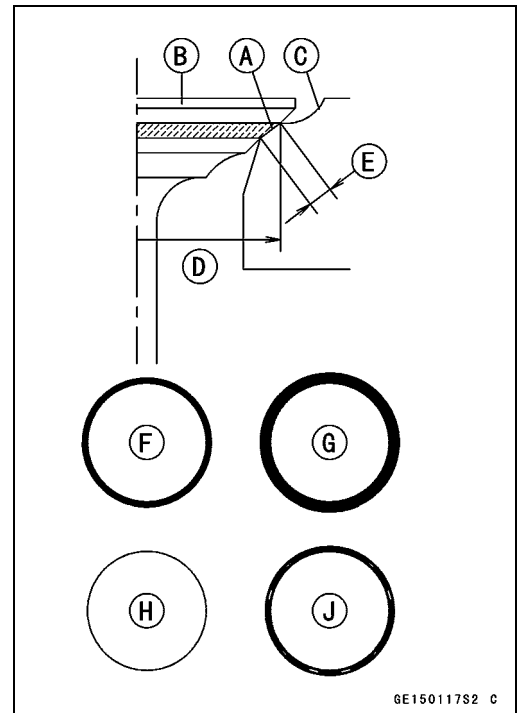

## 5-30 ENGINE TOP END

### Valves

#### Seat Cutter Operation Care

1. This valve seat cutter is developed to grind the valve for repair. Therefore the cutter must not be used for other purposes than seat repair.
2. Do not drop or shock the valve seat cutter, or the diamond particles may fall off.
3. Do not fail to apply engine oil to the valve seat cutter before grinding the seat surface. Also wash off ground particles sticking to the cutter with washing oil.

#### NOTE

○Do not use a wire brush to remove the metal particles from the cutter. It will take off the diamond particles.

4. Setting the valve seat cutter holder in position, operate the cutter in one hand. Do not apply too much force to the diamond portion.

#### NOTE

○Prior to grinding, apply engine oil to the cutter and during the operation, wash off any ground particles sticking to the cutter with washing oil.

5. After use, wash it with washing oil and apply thin layer of engine oil before storing.

#### Marks Stamped on the Cutter

The marks stamped on the back of the cutter [A] represent the following.

- 60° ..... Cutter angle [B]  
φ37.5 ..... Outer diameter of cutter [C]

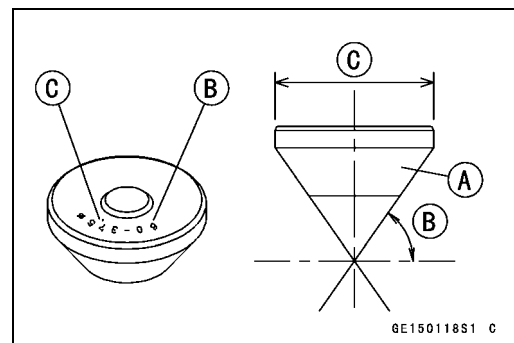

#### Operating Procedures

- Clean the seat area carefully.
- Coat the seat with machinist's dye.
- Fit a 45° cutter into the holder and slide it into the valve guide.
- Press down lightly on the handle and turn it right or left. Grind the seating surface only until it is smooth.

#### CAUTION

**Do not grind the seat too much. Overgrinding will reduce valve clearance by sinking the valve into the head. If the valve sinks too far into the head, it will be impossible to adjust the clearance, and the cylinder head must be replaced.**

**Valves**

- Measure the outside diameter of the seating surface with a vernier caliper.
- ★ If the outside diameter of the seating surface is too small, repeat the 45° grind until the diameter is within the specified range.
  - Widened Width [A] of engagement by machining with 45° cutter
  - Ground Volume [B] by 32° cutter
  - 32° [C]
  - Correct Width [D]
  - Ground Volume [E] by 60° cutter
  - 60° [F]

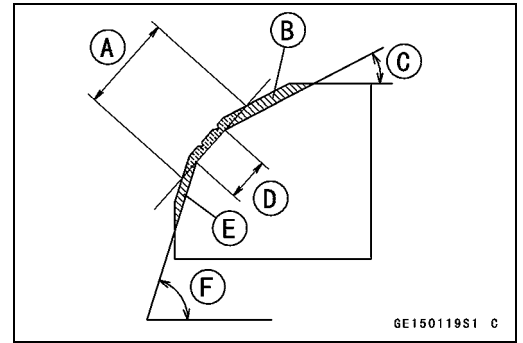

- Measure the outside diameter of the seating surface with a vernier caliper.
- ★ If the outside diameter of the seating surface is too small, repeat the 45° grind [A] until the diameter is within the specified range.
  - Original Seating Surface [B]

**NOTE**

- Remove all pittings of flaws from 45° ground surface.
- After grinding with 45° cutter, apply thin coat of machinist's dye to seating surface. This makes seating surface distinct and 32° and 60° grinding operation easier.
- When the valve guide is replaced, be sure to grind with 45° cutter for centering and good contact.

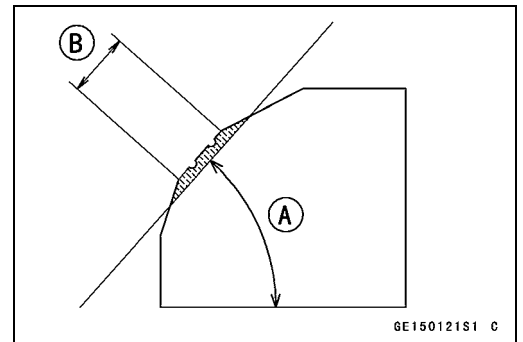

- ★ If the outside diameter [A] of the seating surface is too large, make the 32° grind described below.
- ★ If the outside diameter of the seating surface is within the specified range, measure the seat width as described below.
- Grind the seat at a 32° angle [B] until the seat outside diameter is within the specified range.
  - To make the 32° grind, fit a 32° cutter into the holder, and slide it into the valve guide.
  - Turn the holder one turn at a time while pressing down very lightly. Check the seat after each turn.

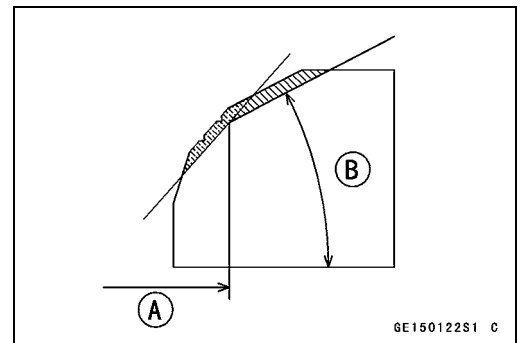

**CAUTION**

**The 32° cutter removes material very quickly. Check the seat outside diameter frequently to prevent overgrinding.**

- After making the 32° grind, return to the seat outside diameter measurement step above.
- To measure the seat width, use a vernier caliper to measure the width of the 45° angle portion of the seat at several places around the seat.
- ★ If the seat width is too narrow, repeat the 45° grind until the seat is slightly too wide, and then return to the seat outside diameter measurement step above.

## 5-32 ENGINE TOP END

### Valves

- ★ If the seat width is too wide, make the 60° [A] grind described below.
- ★ If the seat width is within the specified range, lap the valve to the seat as described below.
- Grind the seat at a 60° angle until the seat width is within the specified range.
- To make the 60° grind, fit 60° cutter into the holder, and slide it into the valve guide.
- Turn the holder, while pressing down lightly.
- After making the 60° grind, return to the seat width measurement step above.  
Correct Width [B]

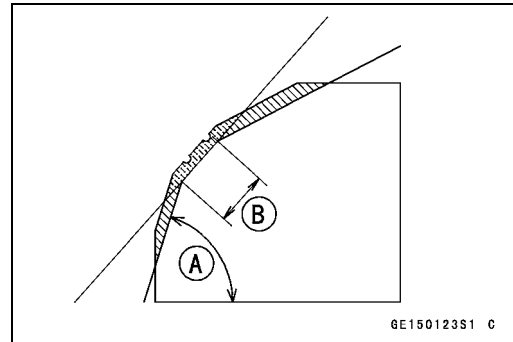

- Lap the valve to the valve seat, once the seat width and outside diameter are within the ranges specified above.
- Put a little coarse grinding compound on the face of the valve in a number of places around the valve head.
- Spin the valve against the seat until the grinding compound produces a smooth, matched surface on both the seat and the valve.
- Repeat the process with a fine grinding compound.  
Lapper [A]  
Valve Seat [B]  
Valve [C]
- The seating area should be marked about in the middle of the valve face.
- ★ If the seat area is not in the right place on the valve, check to be sure the valve is the correct part. If it is, it may have been refaced too much; replace it.
- Be sure to remove all grinding compound before assembly.
- When the engine is assembled, be sure to adjust the valve clearance (see Valve Clearance Inspection in the Periodic Maintenance chapter).

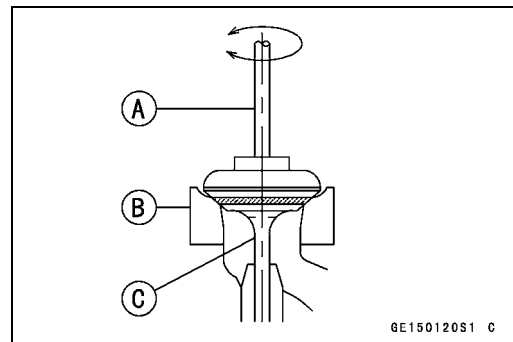

Valves

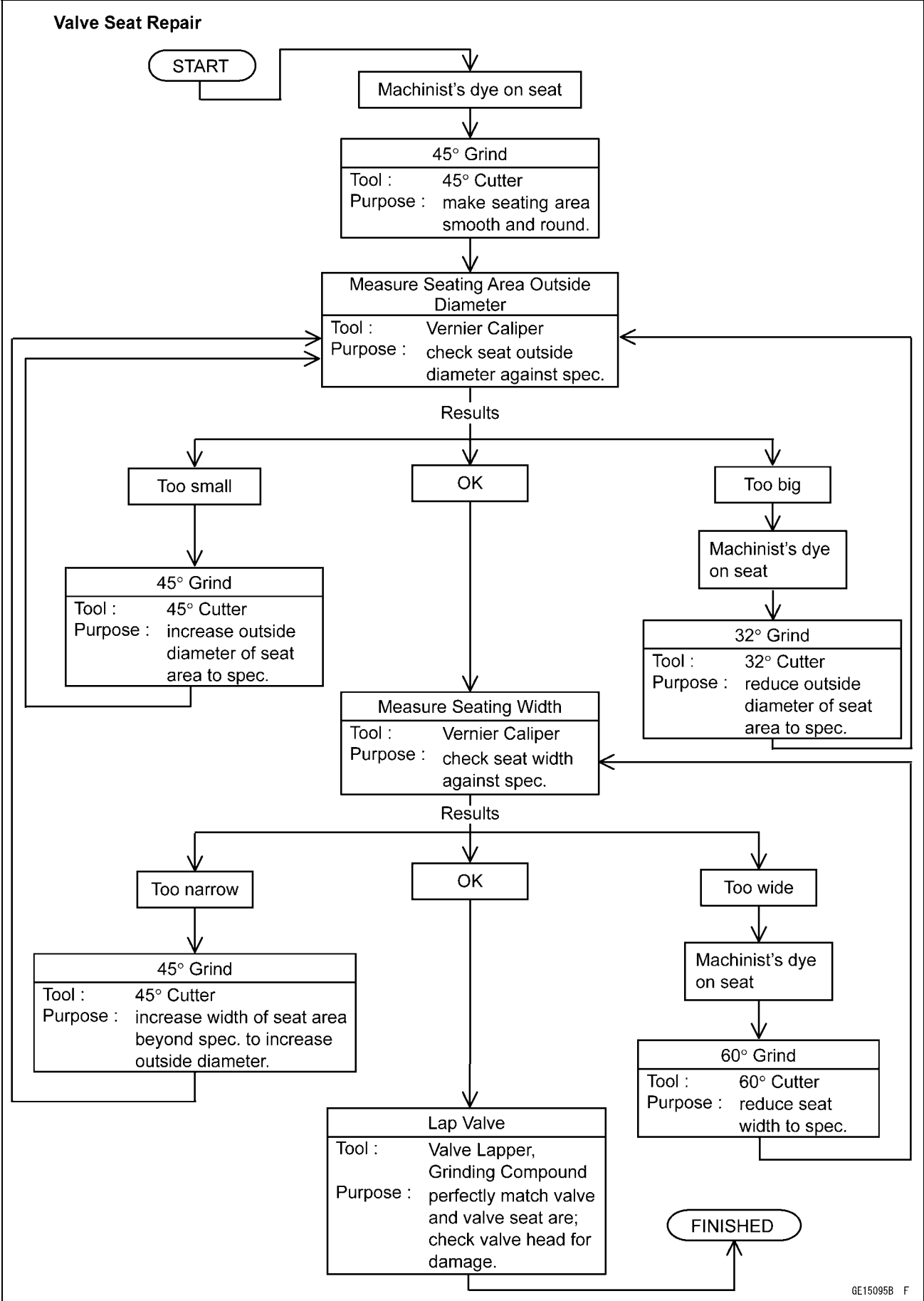

## 5-34 ENGINE TOP END

### Throttle Body Assy Holder

#### **Throttle Body Assy Holder Removal**

- Remove:
  - Fuel Tank (see Fuel Tank Removal in the Fuel System (DFI) chapter)
  - Air Cleaner Housing (Air Cleaner Housing Removal in the Fuel System (DFI) chapter)
  - Throttle Body Assy (Throttle Body Assy Removal in the Fuel System (DFI) chapter)
  - Clamps [A]
  - Holder Bolts [B]
  - Holders [C]

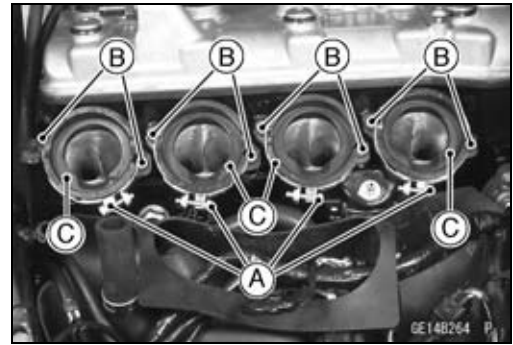

#### **Throttle Body Assy Holder Installation**

- Be sure to install the new O-rings [A].
- Apply grease to the new O-rings.
- Install the clamps [B] as shown.
- Apply a non-permanent locking agent:
  - Throttle Body Assy Holder Bolts [C]
- Tighten:
  - Torque - Throttle Body Assy Holder Bolts: 12 N·m (1.2 kgf·m, 106 in·lb)**
  - Throttle Body Assy Holder Clamp Bolts [D]: 2.9 N·m (0.30 kgf·m, 26 in·lb)**
- Fix the hole of clamp to the projection of holder [E].
  - 10° [F]
  - 25° [G]

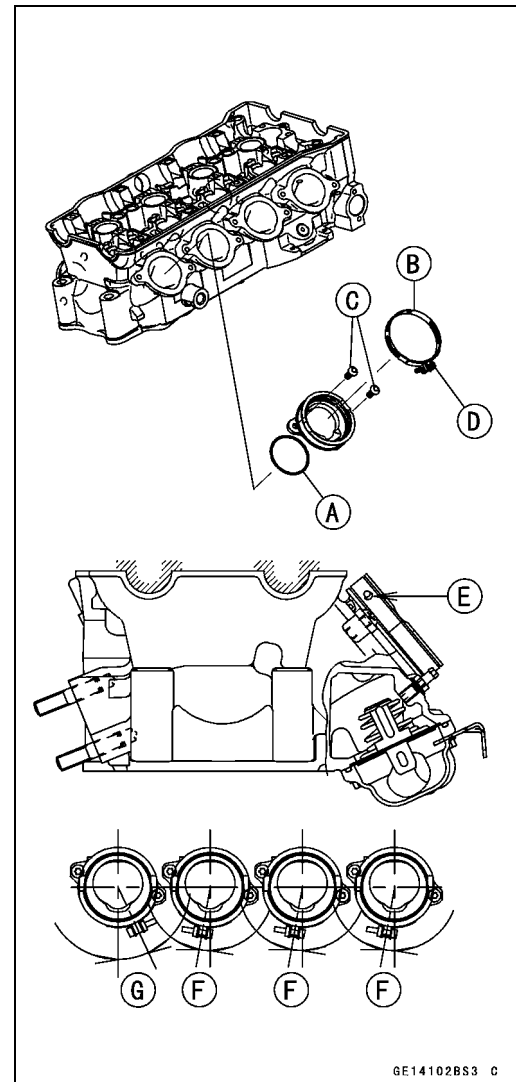

GE14102BS3 C



## Muffler

### **⚠ WARNING**

To avoid a serious burn, do not remove the muffler when the engine is still hot. Wait until the muffler cool down.

### ***Muffler Body Removal***

- Remove:
  - Seat Cover (see Seat Cover Removal in the Frame chapter)
  - Flap (see Flap and Rear Fender Removal in the Frame chapter)
  - Exhaust Butterfly Valve Cable (Muffler Body Side) (see Exhaust Butterfly Valve Cable Removal)
  - Bolts [A] with Washers
- Remove the muffler body [B] backward [C].

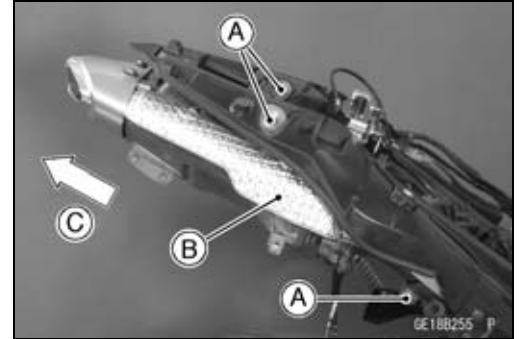

## 5-36 ENGINE TOP END

### Muffler

#### Muffler Body Installation

★ If the muffler body covers were removed, install them.

Muffler Body Upper Cover [A]

Muffler Body Rear Cover [B]

Dampers [C]

○ Tighten:

**Torque - Muffler Body Upper Cover Bolts [D]: 6.9 N·m (0.70 kgf·m, 61 in·lb)**

**Muffler Body Rear Cover Bolts [E]: 6.9 N·m (0.70 kgf·m, 61 in·lb)**

● Replace the muffler body gasket [F] with a new one.

● Install the muffler body gasket into the rear exhaust pipe [G] until it is bottomed so that the chamfer side [H] face to the muffler body [I].

● Touch the gasket stoppers [J] of the muffler body to the end of the gasket.

● Install the muffler body.

○ Pass the muffler stays [K] through the holes of the rear fender.

Upside [L]

Outside [M]

About 8 mm (0.32 in.) [N]

● Tighten:

**Torque - Muffler Body Mounting Bolts [O]: 28 N·m (2.8 kgf·m, 21 ft·lb)**

**Muffler Body Clamp Bolt [P]: 17 N·m (1.7 kgf·m, 12 ft·lb)**

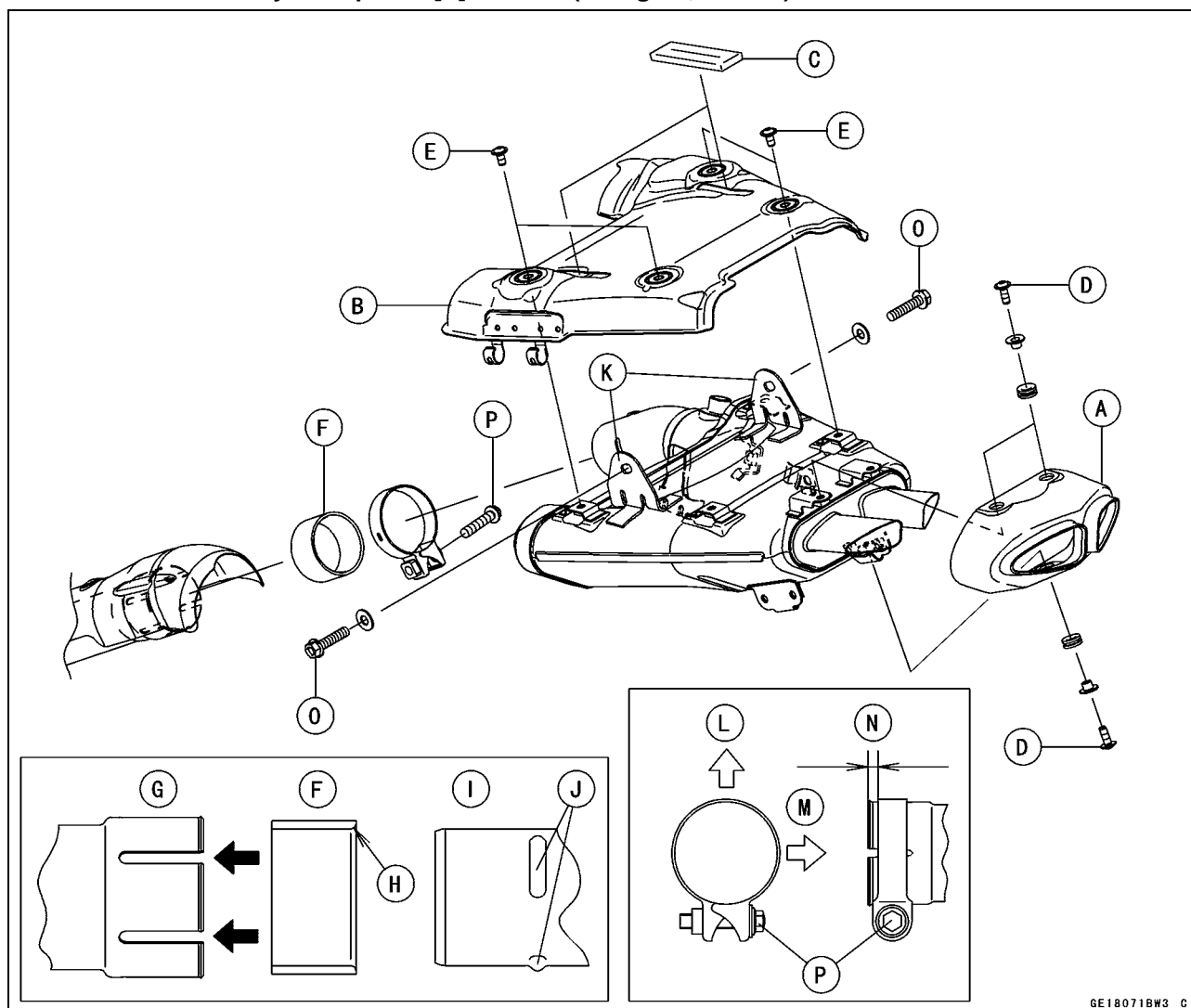

## Muffler

- Install the exhaust butterfly valve cable, and adjust (see Exhaust Butterfly Valve Cable installation).
- Thoroughly warm up the engine, wait until the engine cools down, retighten all the bolts.
- Install the removed parts (see appropriate chapters).

### Rear Exhaust Pipe Removal

- Remove:
  - Muffler Body (see Muffler Body Removal)
  - Cover Bolts [A]
  - Cover [B] (move)

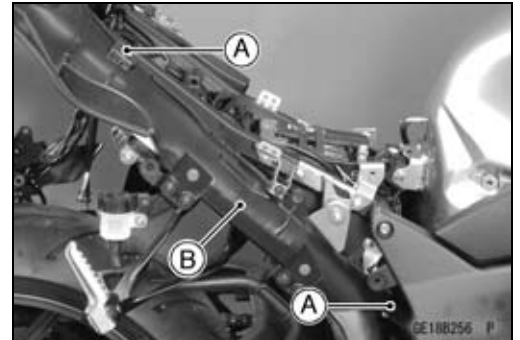

- Remove:
  - Rear Footpeg Bracket Bolts [A]
  - Rear Footpeg Bracket [B] (move)

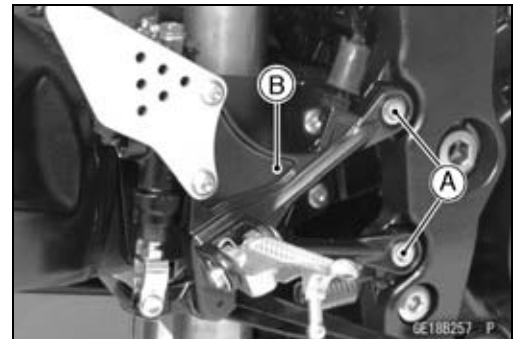

- Remove:
  - Bolts [A]
  - Cover [B]

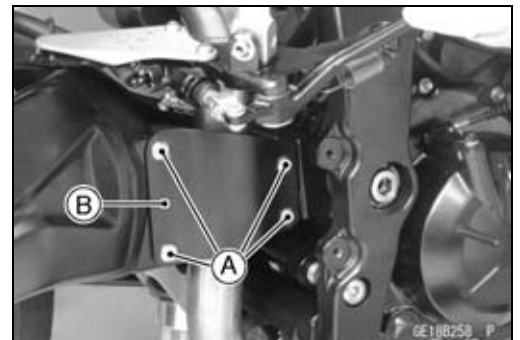

- Remove:
  - Bolts [A]
  - Rear Exhaust Pipe [B]

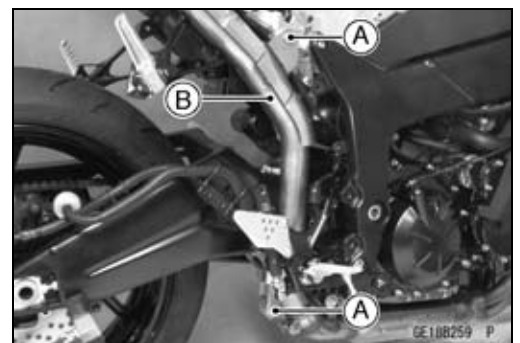

## 5-38 ENGINE TOP END

### Muffler

#### Rear Exhaust Pipe Installation

- Replace the rear exhaust pipe gasket [A] with a new one.
- Install the rear exhaust pipe gasket until it is bottomed so that the chamfer side [B] faces to the rear exhaust pipe [C].
- Touch the gasket stopper [D] of the rear exhaust pipe to the end of the gasket.
- Install the rear exhaust pipe clamp bolt [E] as shown.
- Install the rear exhaust pipe.
  - Front Exhaust Pipe [F]
  - Upside [G]
  - Outside [H]
  - About 6 mm (0.24 in.) [I]
- Tighten:
  - Torque - Rear Exhaust Pipe Mounting Bolt [J]: 28 N·m (2.8 kgf·m, 21 ft·lb)**
  - Rear Exhaust Pipe Clamp Bolt: 17 N·m (1.7 kgf·m, 13 ft·lb)**
- Install the muffler body (see Muffler Body Installation).

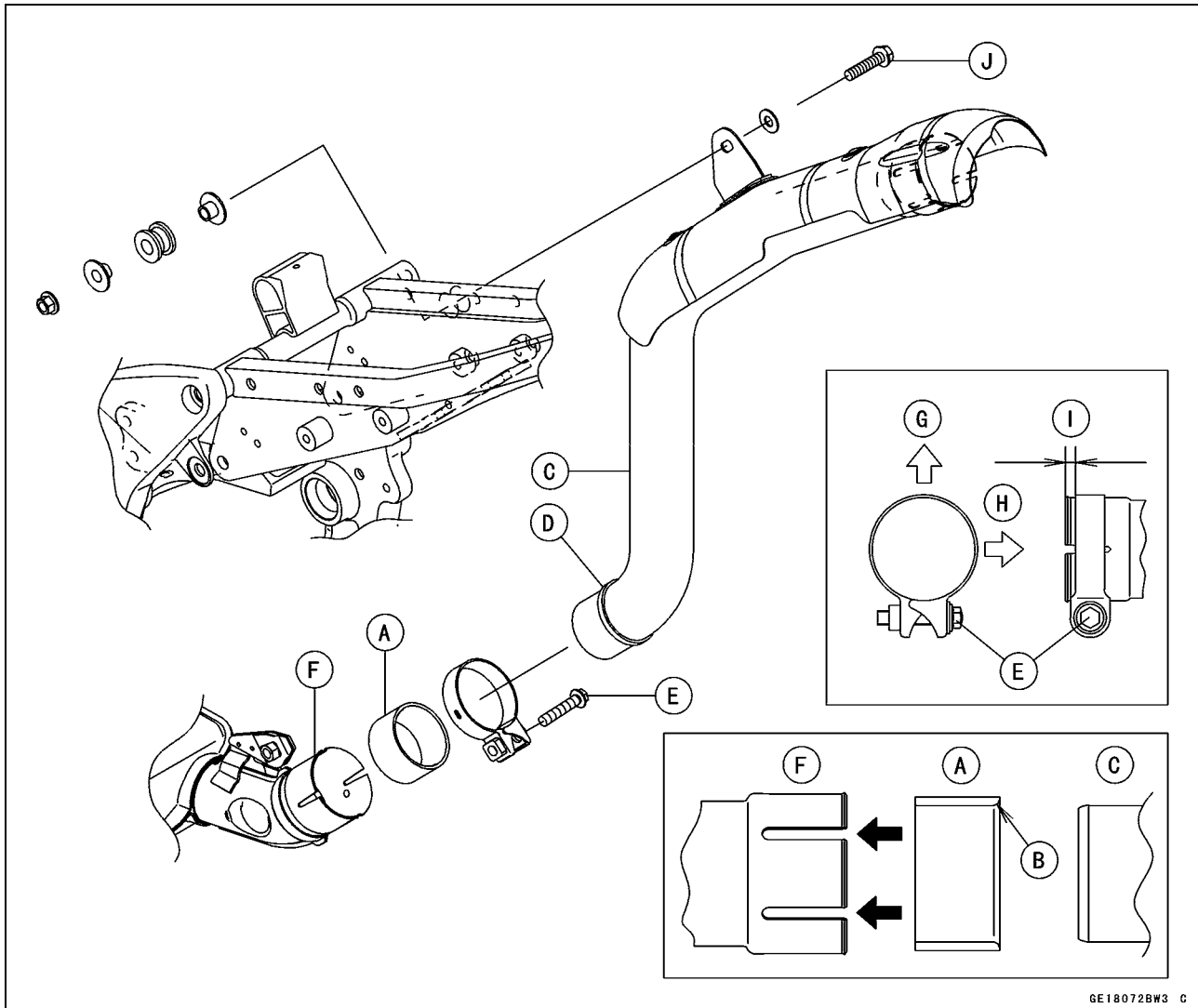

GE18072BW3 C

- Thoroughly warm up the engine, wait until the engine cools down, retighten all the bolts.
- Install the removed parts (see appropriate chapters).

## Muffler

### *Front Exhaust Pipe Removal*

- Remove:
  - Radiator Lower Bolt [A] (see Radiator and Radiator Fan Removal in the Cooling System chapter)
- Loosen the radiator upper bolts.
- Remove:
  - Oxygen Sensor Lead Connectors (see Oxygen Sensor Removal (Equipped Models) in the Electrical System chapter)
  - Front Exhaust Pipe Holder Nuts [B]
  
- Loosen the rear exhaust pipe clamp bolt [A].
- Remove the front exhaust pipe mounting bolt [B].
- Remove the front exhaust pipe [C] forward [D].

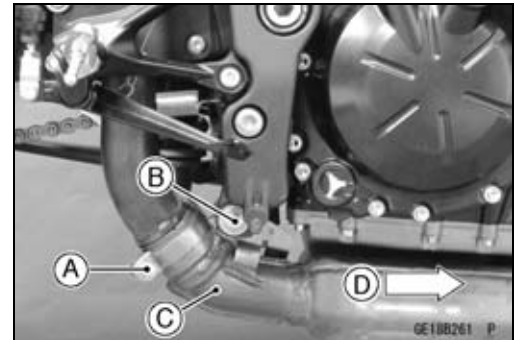
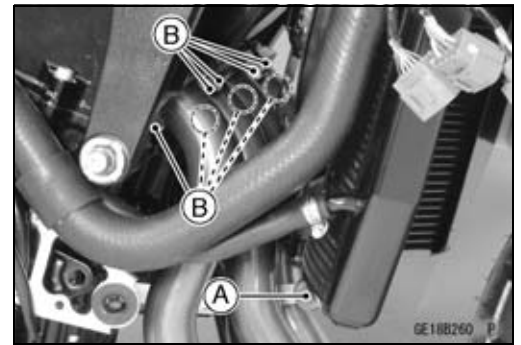

## 5-40 ENGINE TOP END

### Muffler

#### Front Exhaust Pipe Installation

- Replace the front exhaust pipe gaskets [A] with new ones.
- Replace the rear exhaust pipe gasket [B] with a new one.
- Install the rear exhaust pipe gasket until it is bottomed so that the chamfer side [C] faces to the rear exhaust pipe [D].
- Install the front exhaust pipe [E].
- Touch the gasket stoppers [F] of the rear exhaust pipe to the end of the gasket.
- Install the rear exhaust pipe clamp bolt [G] as shown.
  - Upside [H]
  - Outside [I]
  - About 6 mm (0.24 in.) [J]
  - Viewed from Rear [K]
- Tighten:
  - Torque - Front Exhaust Pipe Holder Nuts [L]: 17 N·m (1.7 kgf·m, 13 ft·lb)**
  - Front Exhaust Pipe Mounting Bolt [M]: 28 N·m (2.8 kgf·m, 21 ft·lb)**
  - Rear Exhaust Pipe Clamp Bolt: 17 N·m (1.7 kgf·m, 13 ft·lb)**
- For the Europe Models, route the oxygen sensor leads correctly (see Cable, Wire, and Hose Routing section in the Appendix chapter).

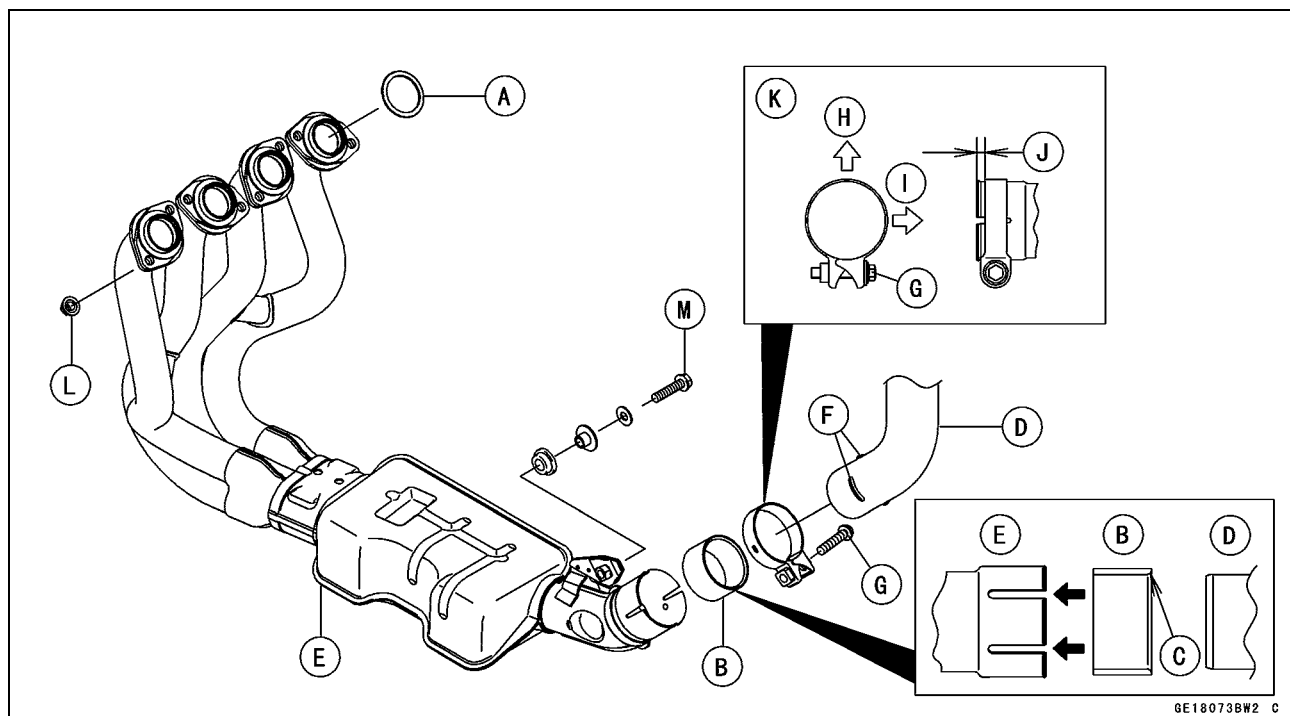

- Tighten the radiator lower and upper bolts (see Radiator and Radiator Fan Installation in the Cooling System chapter).
- Thoroughly warm up the engine, wait until the engine cools down, retighten all the bolt and nuts.

## Muffler

### ***Exhaust Butterfly Valve Cable Removal***

- Remove:
  - Seat Cover (see Seat Cover Removal in the Frame chapter)
  - Bolt [A]
  - Exhaust Butterfly Valve Cover [B]

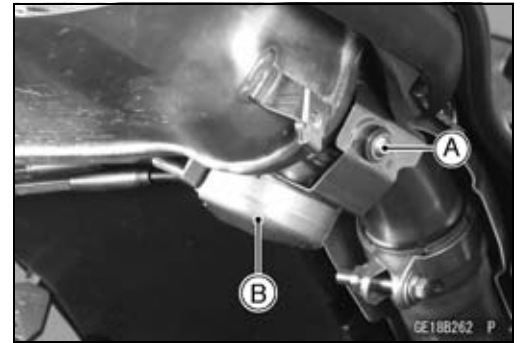

- Slide the dust covers [A].
- Loosen the adjuster locknuts [B], and turn the adjuster [C] to give the cable plenty of play.
- Loosen the locknuts [D].
- Remove the exhaust butterfly valve cable lower ends [E] from the pulley [F].

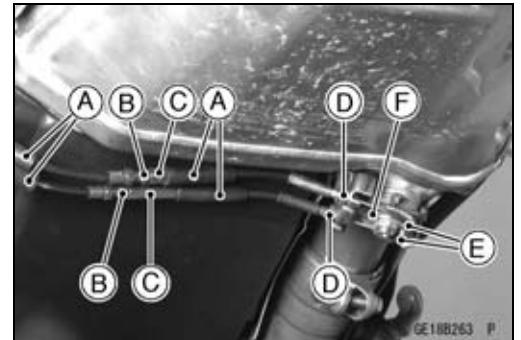

- Remove the clamp [A].
- Remove the exhaust butterfly valve cable upper ends [B] from the pulley [C].
- Remove the exhaust butterfly valve cables [D].

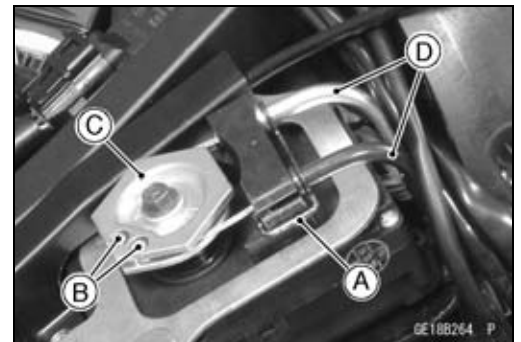

## 5-42 ENGINE TOP END

### Muffler

#### **Exhaust Butterfly Valve Cable Installation**

- Install the exhaust butterfly valve cable lower ends to the pulley of muffler body.
  - Open Cable (White) [A]
  - Close Cable (Black) [B]
- Tighten:
  - Torque - Exhaust Butterfly Valve Cable Locknuts: 6.9 N·m (0.70 kgf·m, 61 in·lb)**
- Install the grommet [C] to the exhaust butterfly valve cables, and put the grommet into the notch of the rear fender.
- Install the exhaust butterfly valve cover [D].
- Tighten:
  - Torque - Exhaust Butterfly Valve Cover Bolt: 6.9 N·m (0.70 kgf·m, 61 in·lb)**
- Confirm whether it is an angle shown in the figure.

#### **NOTE**

○ *Correct the position electrically after confirming use is discontinued and there is no damage when differing from the angle of shown in the figure.*

- ★ If the angle is wrong, adjust the pulley (see Exhaust Butterfly Valve Actuator Installation in the Fuel System (DFI) chapter).  
41.7° ±7° [E]

<b>CAUTION</b>
<b>Do not correct it with the tool, forcibly. The actuator damage will occur.</b>

- Install the exhaust butterfly valve cable upper ends to the pulley of actuator.
  - Open Cable (White) [F]
  - Close Cable (Black) [G]
  - Upside View [H]
- Install the clamp [I] securely.



## Muffler

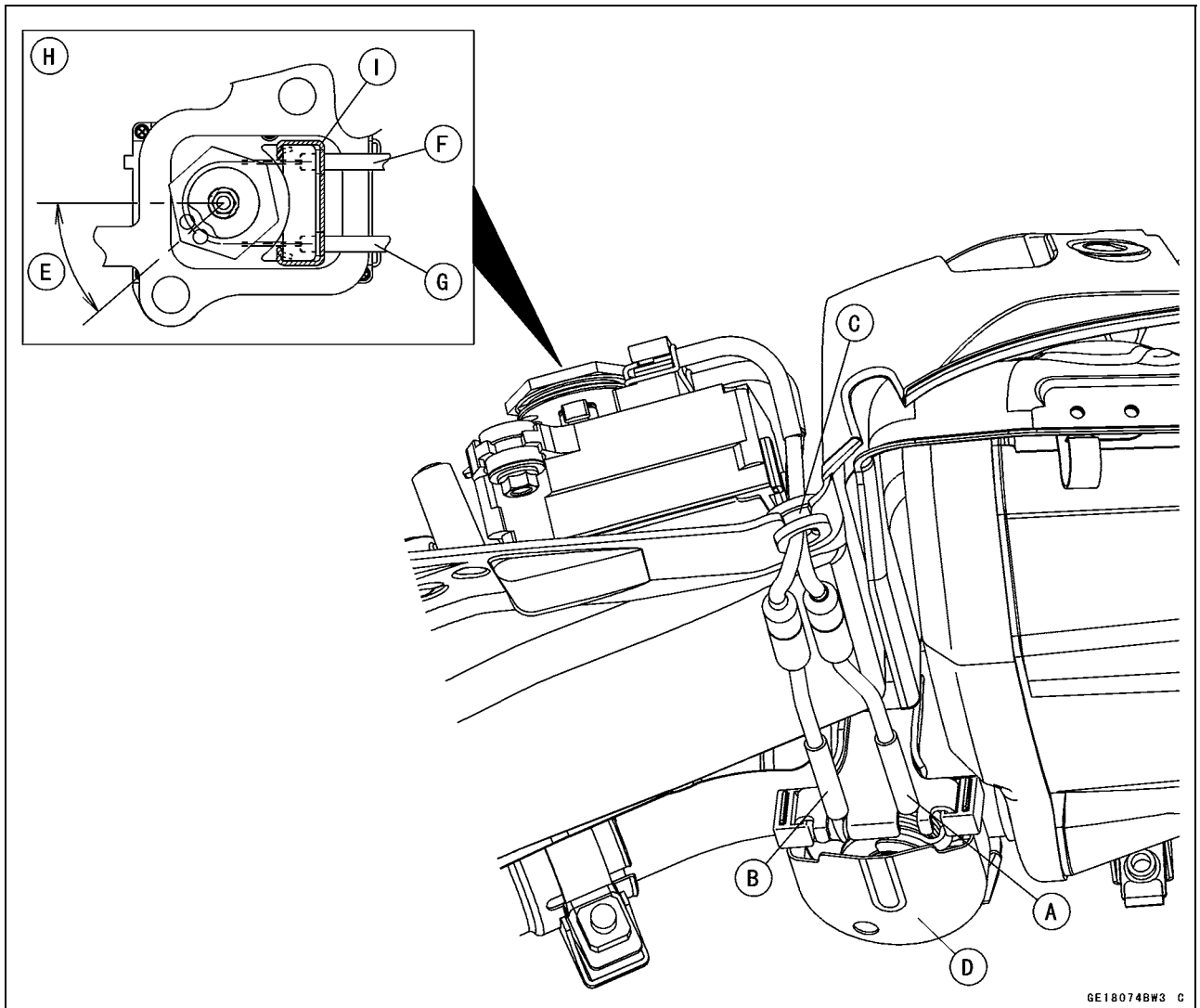

GE18074BW3 C

- Stretch the open cable (white) first by using the adjuster [A].
- Turn the adjuster counterclockwise until the play of the open cable becomes no play.

**CAUTION**

**To keep the correct exhaust butterfly valve position, adjust the open cable first.**  
**Do not overstretch. If the adjustment of the exhaust butterfly valve cables is incorrect, the exhaust butterfly valve actuator does not operate correctly.**

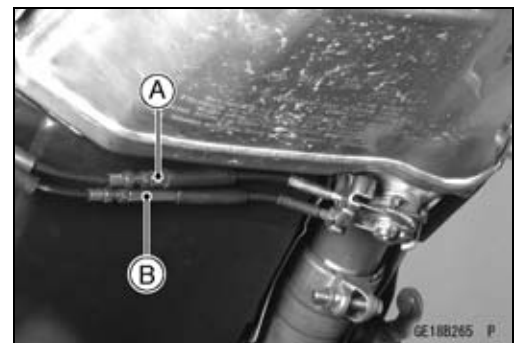

GE118265 P

- Tighten:
  - Torque - Exhaust Butterfly Valve Cable Adjuster Locknut:  
6.9 N·m (0.70 kgf·m, 61 in·lb)
- Stretch the close cable (black) by using the adjuster [B].
- Turn the adjuster counterclockwise until the play of the close cable becomes no play.
- Then, return the adjuster of the close cable by about 3/4 rotation.

## 5-44 ENGINE TOP END

---

### Muffler

---

- Tighten:
  - Torque - Exhaust Butterfly Valve Cable Adjuster Locknut:  
6.9 N·m (0.70 kgf·m, 61 in·lb)**
- Cover the dust covers.
- Install the removed parts (see appropriate chapters).
  
- Confirm the operation of the pulley as follows.
  - Turn the ignition switch ON.
  - Confirm the pulley turns clockwise and then counterclockwise, and clockwise again.
  - ★ If the operation of the pulley is different, readjust the exhaust butterfly valve cables.
  - Confirm the pulley angle ( $41.7^\circ \pm 7^\circ$ ).
  - ★ If the angle is wrong, adjust the pulley (see Exhaust Butterfly Valve Actuator Installation in the Fuel System (DFI) chapter) and readjust the exhaust butterfly valve cables.
  - Start the engine. Open the throttle, and then confirm the operation of the pulley.
  - ★ If the pulley does not operate, readjust the exhaust butterfly valve cables.

# Clutch

## Table of Contents

Exploded View .....	6-2
Specifications .....	6-4
Special Tool and Sealant .....	6-5
Clutch Lever and Cable .....	6-6
Clutch Lever Free Play Inspection .....	6-6
Clutch Lever Free Play Adjustment .....	6-6
Cable Removal .....	6-6
Cable Installation .....	6-6
Cable Lubrication .....	6-6
Clutch Lever Installation .....	6-6
Clutch Cover .....	6-7
Clutch Cover Removal .....	6-7
Clutch Cover Installation .....	6-7
Release Shaft Removal .....	6-7
Release Shaft Installation .....	6-8
Clutch Cover Disassembly .....	6-8
Clutch Cover Assembly .....	6-9
Clutch .....	6-10
Clutch Removal .....	6-10
Clutch Installation .....	6-10
Spring Plate Free Play Measurement .....	6-13
Spring Plate Free Play Adjustment .....	6-14
Clutch Plate, Wear, Damage Inspection .....	6-15
Clutch Plate Warp Inspection .....	6-15
Clutch Spring Free Length Measurement .....	6-16
Damper Cam Inspection .....	6-16

# 6-2 CLUTCH

## Exploded View

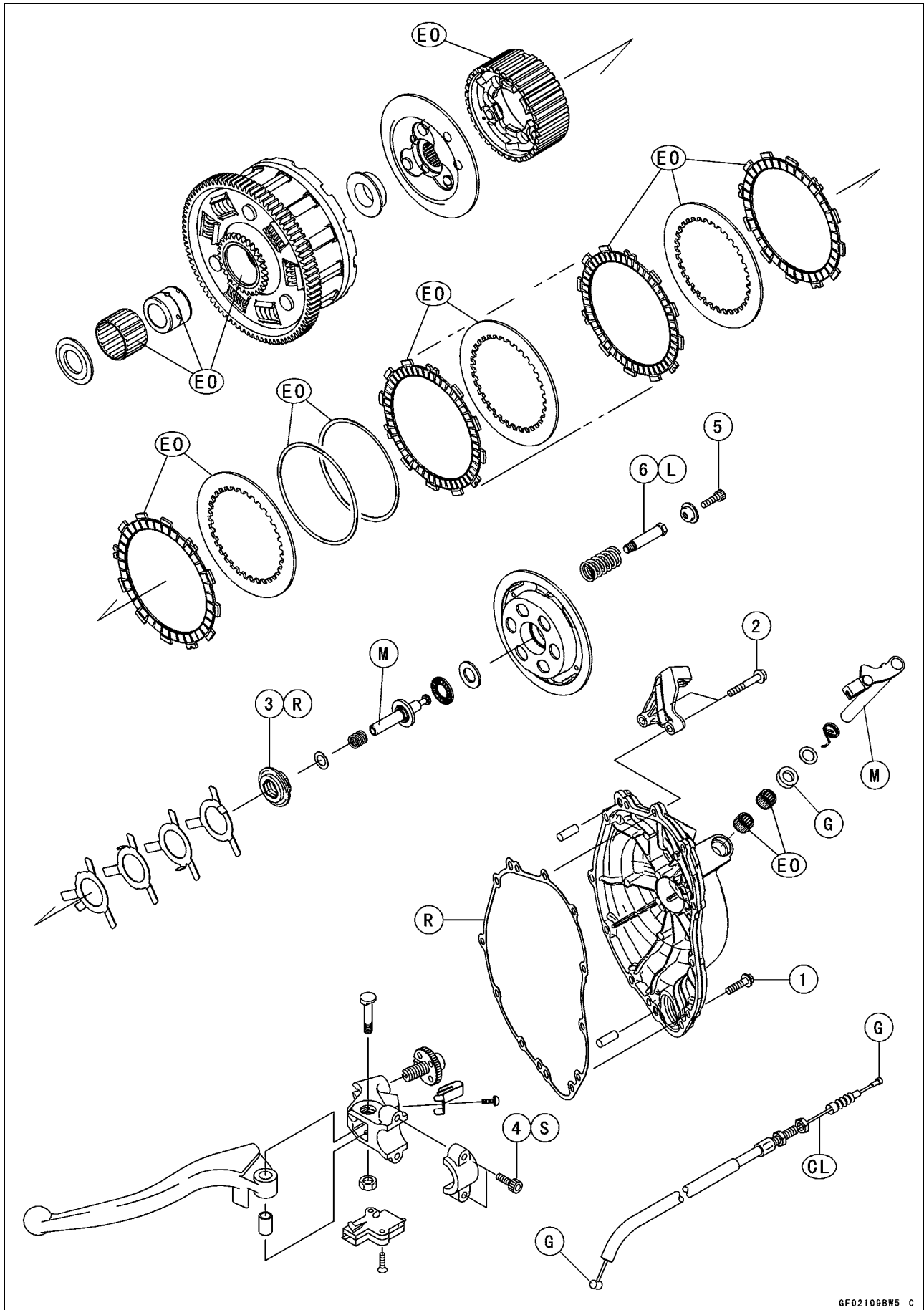

## Exploded View

No.	Fastener	Torque			Remarks
		N·m	kgf·m	ft·lb	
1	Clutch Cover Bolts (M6, L = 25 mm)	9.8	1.0	87 in·lb	
2	Clutch Cover Bolts (M6, L = 40 mm)	9.8	1.0	87 in·lb	
3	Clutch Hub Nut	135	14	100	R
4	Clutch Lever Clamp Bolts	7.8	0.80	69 in·lb	S
5	Clutch Spring Bolts	8.8	0.90	78 in·lb	
6	Sub Clutch Hub Bolts	25	2.5	18	L

CL: Apply cable lubricant.

EO: Apply engine oil.

G: Apply grease.

L: Apply a non-permanent locking agent.

M: Apply molybdenum disulfide grease.

R: Replacement Parts

S: Follow the specified tightening sequence.

## 6-4 CLUTCH

### Specifications

Item	Standard	Service Limit
<b>Clutch Lever Free Play</b>	2 ~ 3 mm (0.08 ~ 0.12 in.)	— — —
<b>Clutch</b>		
Spring Plate Free Play	(Usable Range) 0.05 ~ 0.70 mm (0.002 ~ 0.028 in.)	— — —
Clutch Plate Assembly Length	(Reference) 40.6 mm (1.60 in.)	— — —
Friction Plate Thickness	2.72 ~ 2.88 mm (0.107 ~ 0.113 in.)	2.5 mm (0.098 in.)
Friction and Steel Plate Warp	0.15 mm (0.006 in.) or less	0.3 mm (0.012 in.)
Clutch Spring Free Length	41.6 mm (1.64 in.)	40.1 mm (1.58 in.)

**Special Tool and Sealant**

**Clutch Holder:**  
**57001-1243**

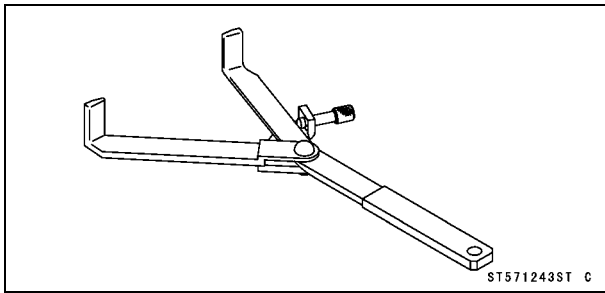

**Kawasaki Bond (Silicone Sealant):**  
**92104-0004**

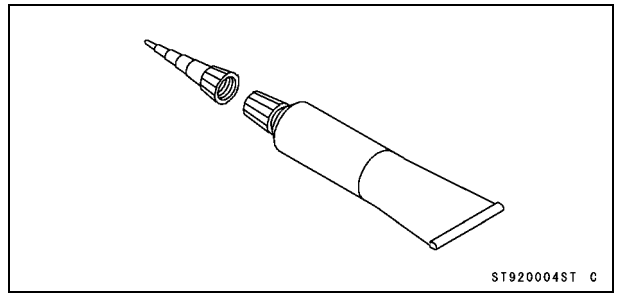

## 6-6 CLUTCH

### Clutch Lever and Cable

#### **Clutch Lever Free Play Inspection**

- Refer to the Clutch Operation Inspection in the Periodic Maintenance chapter.

#### **Clutch Lever Free Play Adjustment**

- Refer to the Clutch Operation Inspection in the Periodic Maintenance chapter.

#### **Cable Removal**

- Remove the right middle fairing (see Middle Fairing Removal in the Frame chapter).
- Slide the dust cover [A] at the clutch cable lower end out of place.
- Loosen the nuts [B], and slide the lower end of the clutch cable to give the cable plenty of play.

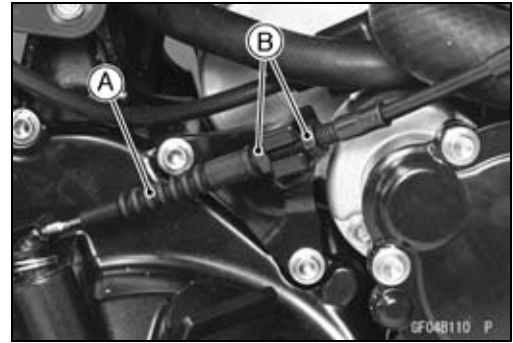

- Screw in the adjuster.
- Line up the slots [A] in the clutch lever and adjuster [B], and then free the cable from the lever.
- Free the clutch inner cable tip from the clutch release lever.
- Push the release lever toward the front of the motorcycle and tape the release lever to the clutch cover to prevent the release shaft from falling out.
- Pull the clutch cable out of the frame.

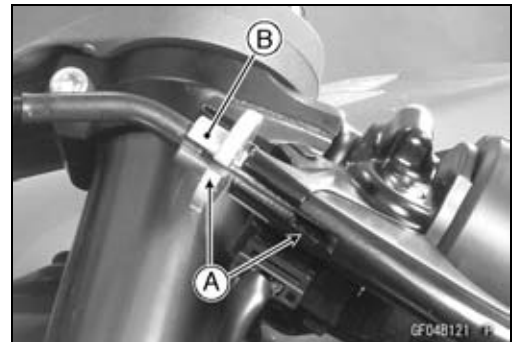

#### **Cable Installation**

- Run the clutch cable correctly (see Cable, Wire, and Hose Routing section in the Appendix chapter).
- Adjust the clutch cable (see Clutch Operation Inspection in the Periodic Maintenance chapter).

#### **Cable Lubrication**

- Refer to the Chassis Parts Lubrication in the Periodic Maintenance chapter.

#### **Clutch Lever Installation**

- Install the clutch lever so that the mating surface [A] of the clutch lever clamp is aligned with the punch mark [B].
- Tighten the upper clamp bolt first, and then the lower clamp bolt.
- There will be a gap at the lower part of the clamp after tightening.

**Torque - Clutch Lever Clamp Bolts: 7.8 N·m (0.80 kgf·m, 69 in·lb)**

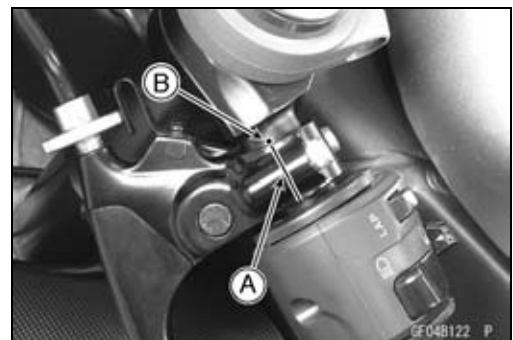



## Clutch Cover

### Clutch Cover Removal

- Drain the engine oil (see Engine Oil Change in the Periodic Maintenance chapter).
- Remove:
  - Right Middle Fairing (see Middle Fairing Removal in the Frame chapter)
  - Clutch Cable Lower End [A] (see Cable Removal)
  - Clutch Cover Bolts [B]
  - Bracket [C]
- Turn the release lever [A] toward the rear as shown, and remove the clutch cover [B].  
About 90° [C]

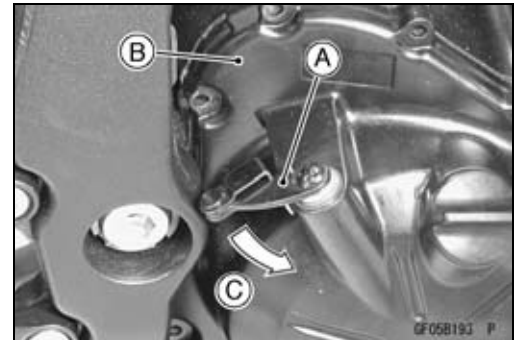
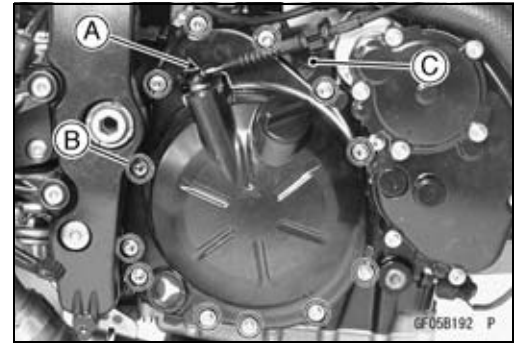

### Clutch Cover Installation

- Apply silicone sealant to the area [A] where the mating surface of the crankcase touches the clutch cover gasket.
- Sealant - Kawasaki Bond (Silicone Sealant): 92104-0004**
- Be sure that the dowel pins [B] are in position.

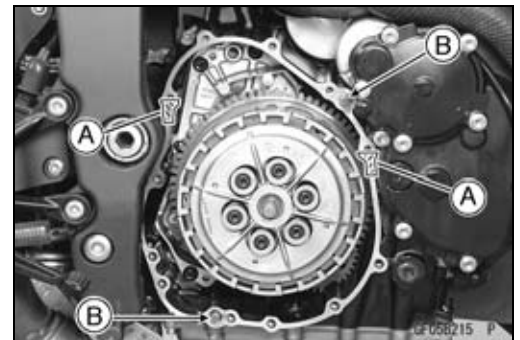

- Replace the clutch cover gasket with a new one.
- Install the bracket [A].
- Tighten the clutch cover bolts.
- Torque - Clutch Cover Bolts: 9.8 N·m (1.0 kgf·m, 87 in·lb)**
  - L = 25 mm (0.98 in.) [B]
  - L = 40 mm (1.57 in.) [C]

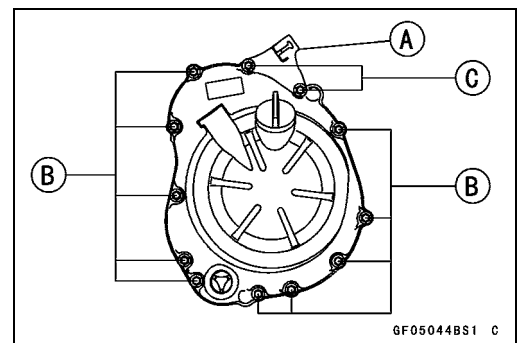

### Release Shaft Removal

#### CAUTION

**Do not remove the clutch release lever and shaft assembly unless it is absolutely necessary. If removed, the oil seal replacement may be required.**

- Remove the clutch cover (see Clutch Cover Removal).
- Pull the lever and shaft assembly [A] straight out of the clutch cover.

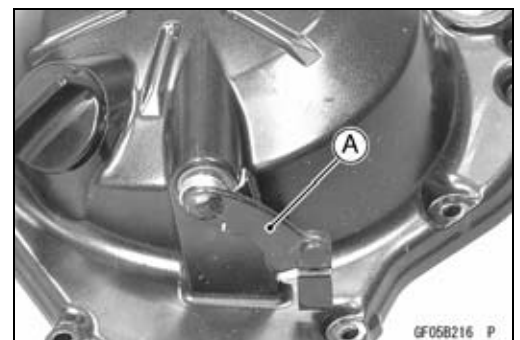

## 6-8 CLUTCH

### Clutch Cover

#### Release Shaft Installation

- Apply grease to the oil seal lips on the upper ridge of the clutch cover.
- Apply engine oil to the needle bearings in the hole of the clutch cover.
- Apply molybdenum disulfide grease to the pusher-holding portion [A] on the release shaft.
- Install the washer [B] and spring [C].
- Insert the release shaft straight into the upper hole of the clutch cover.

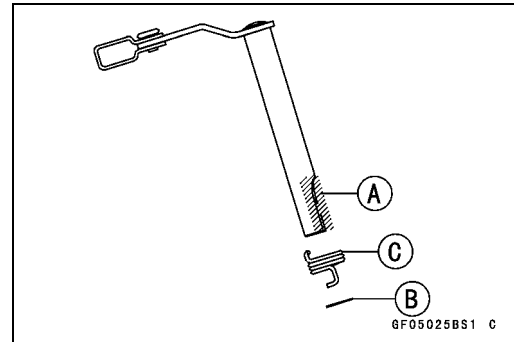

#### CAUTION

**When inserting the release shaft, be careful not to remove the spring of the oil seal.**

- Fit the spring [A] as shown.  
Viewed from Rear [B]  
Release Shaft [C]  
Clutch Cover [D]

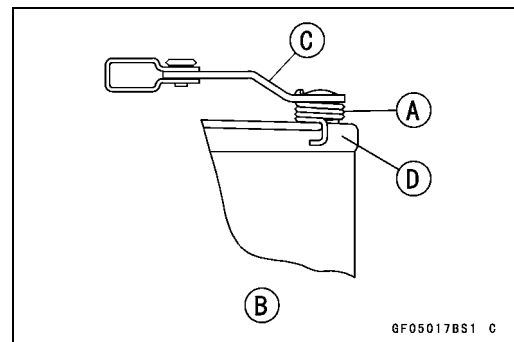

#### Clutch Cover Disassembly

- Remove:  
Clutch Cover (see Clutch Cover Removal)  
Release Lever and Shaft Assembly (see Release Shaft Removal)  
Oil Seal [A]  
Oil Filler Cap [B]  
Oil Level Gauge [C]

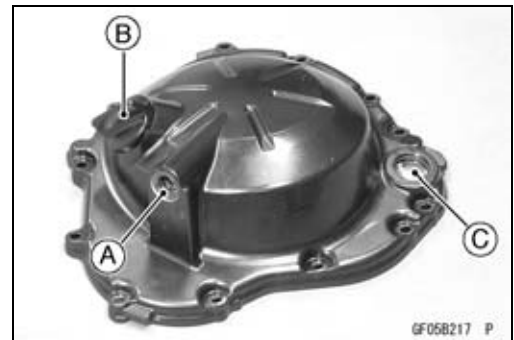

- Remove the needle bearings [A].



## Clutch Cover

### Clutch Cover Assembly

- Replace the needle bearings and oil seal with new ones.

#### NOTE

- Install the needle bearings so that the manufacture's mark face out.
- Install the needle bearings [A] and oil seal [B] as shown.
- Press the bearing, do not protrude from the boss [C] of the clutch cover.
- Press the bearing so that the bearing surface [D] is flush with the housing end of clutch cover [E].
- Press the oil seal until the bottom.
- Apply water to the rubber portion [A] of the oil level gauge.
- Press the gauge so that its projection [B] faces inside of the clutch cover [C].
- Replace the O-ring of the oil filler cap.
- Apply grease to the new O-ring.
- Tighten:
  - Torque - Oil Filler Cap: 2.0 N·m (0.20 kgf·m, 17 in·lb)**

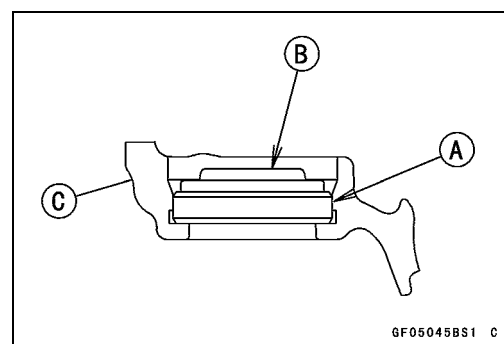
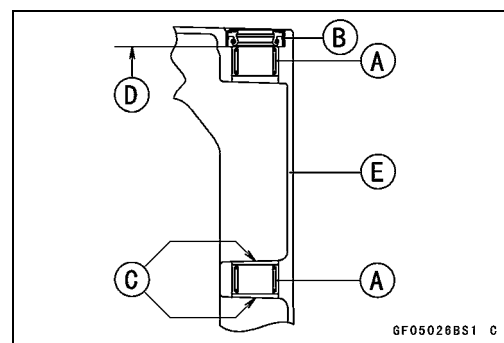

## 6-10 CLUTCH

### Clutch

#### Clutch Removal

- Remove:
  - Clutch Cover (see Clutch Cover Removal)
  - Clutch Spring Bolts [A]
  - Clutch Springs (with Spring Holders)
  - Clutch Spring Plate [B] (with Shim, Bearing, Pusher [C], Spring and Washer)

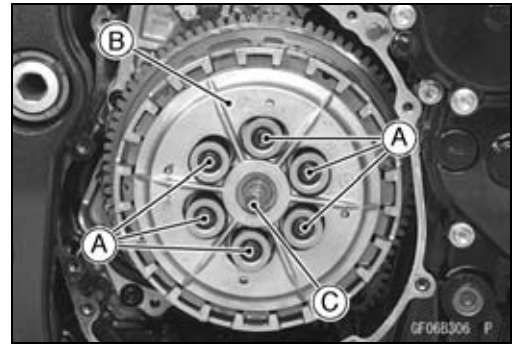

- Remove:
  - Friction Plates, Steel Plates
  - Spring, Spring Seat
- Hold the sub clutch hub [A] steady with the clutch holder [B], and remove the nut [C].

**Special Tool - Clutch Holder: 57001-1243**

- Remove:
  - Torque Limiter Springs [D]
  - Sub Clutch Hub
  - Clutch Hub
  - Spacer
- Using the two 4 mm (0.16 in.) screws [A], pull out the sleeve [B], needle bearing [C] and clutch housing [D].
- Remove the spacer.

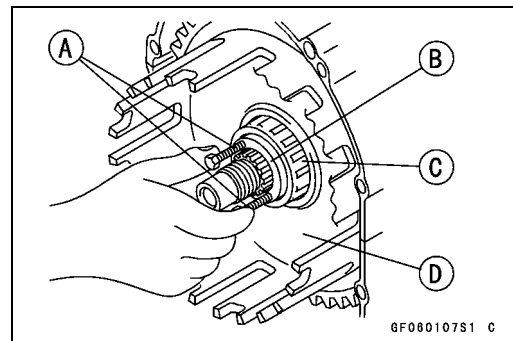
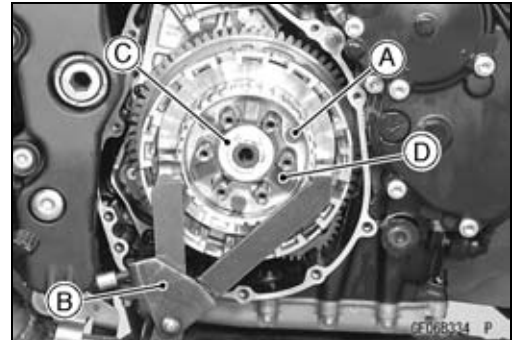

#### Clutch Installation

- Install the spacer [A] so that the stepped side [B] faces inward.

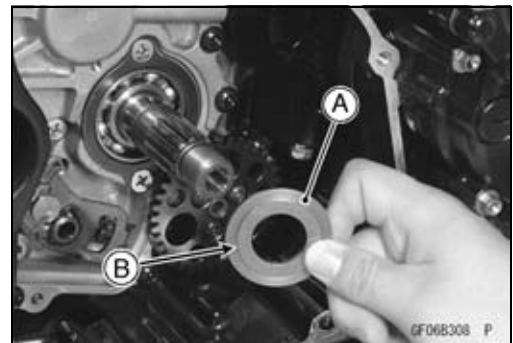

**Clutch**

- Install:
  - Clutch Housing [A]
  - Needle Bearing [B]
- Install the sleeve [C] so that holes [D] face outward.
- Apply engine oil to the sleeve and needle bearing.

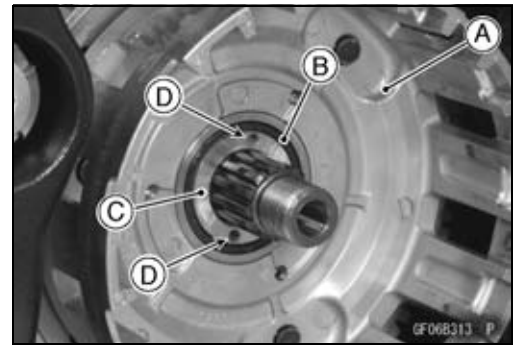

- Install the spacer [A] so that the stepped side [B] faces outward.

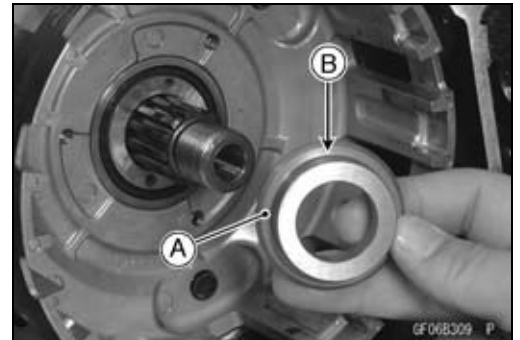

- Install the clutch hub [A] on the drive shaft.
- Align the damper cam [B] of the sub clutch hub [C] to the cam followers [D] of the clutch hub.

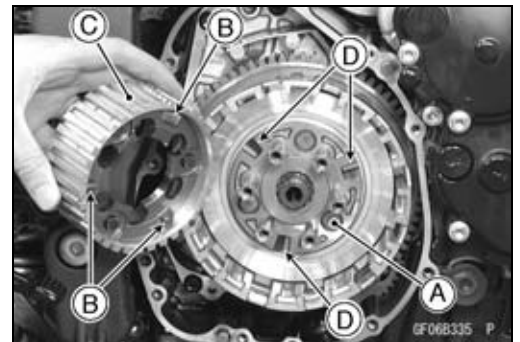

- Install the four torque limiter springs as shown.
  - First Torque Limiter Spring [A]
  - Tang [B]

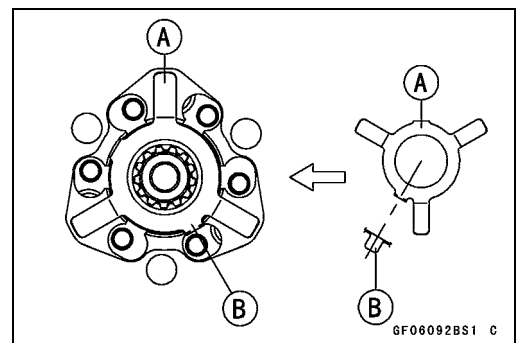

- Second Torque Limiter Spring [A]
- Tang [B]

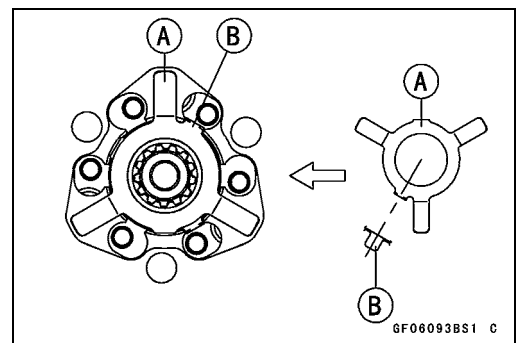

## 6-12 CLUTCH

### Clutch

- Third Torque Limiter Spring [A]  
Tang [B]

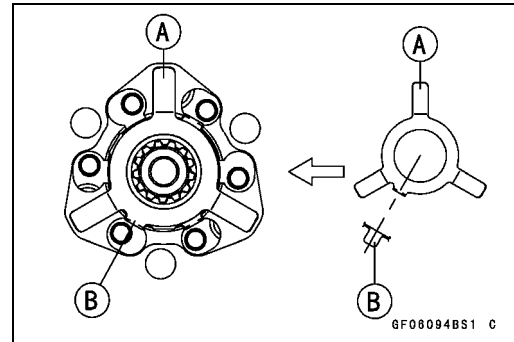

- Fourth Torque Limiter Spring [A]  
Tang [B]

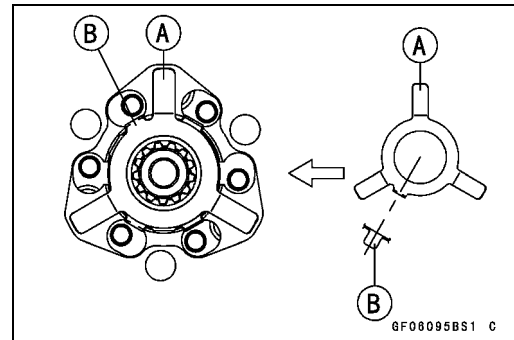

- Replace the clutch hub nut with a new one.
- Hold the sub clutch hub steady with the clutch holder, and tighten the clutch hub nut.

**Special Tool - Clutch Holder: 57001-1243**

**Torque - Clutch Hub Nut: 135 N·m (14 kgf·m, 100 ft·lb)**

- Install the following as shown.
  - Friction Plate (36 lining blocks) [A]
  - Friction Plates (48 lining blocks) [B]
  - Steel Plates [C]
  - Spring Seat [D]
  - Spring [E]

#### NOTE

- The lining blocks [F] of the friction plate [A] are larger than them of the friction plates [B].
- Install the spring seat and spring between first steel plate and second steel plate.

#### CAUTION

If new dry friction plates and steel plates are installed, apply engine oil to the surfaces of each plate to avoid clutch plate seizure.

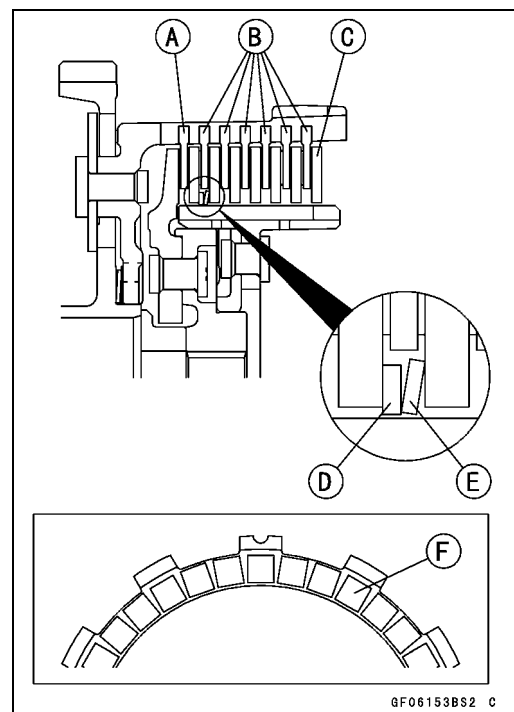

**Clutch**

- Install the last friction plate (36 lining blocks) [A] fitting the tangs in the grooves in the housing as shown.

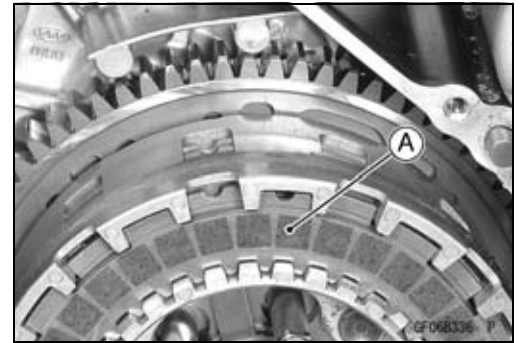

- Apply molybdenum disulfide grease to the pusher ends [A].
- Install the washer [B], spring [C], bearing [D] and shim [E] to the pusher.
- Install the pusher to the drive shaft [F] direction as shown.

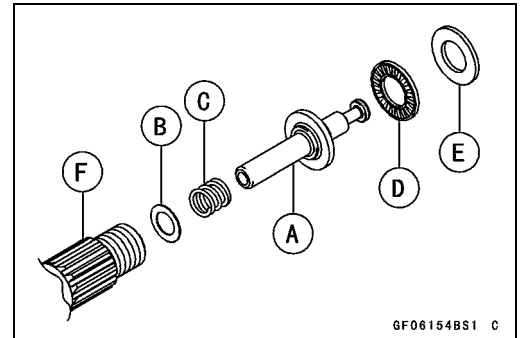

- Align the projections [A] of the spring plate [B] to the grooves [C] of the sub clutch hub [D] to install the spring plate on the sub clutch hub.
- Install the springs and spring holders, and tighten the clutch spring bolts.

**Torque - Clutch Spring Bolts: 8.8 N·m (0.90 kgf·m, 78 in·lb)**

- Install the clutch cover (see Clutch Cover Installation in this chapter).

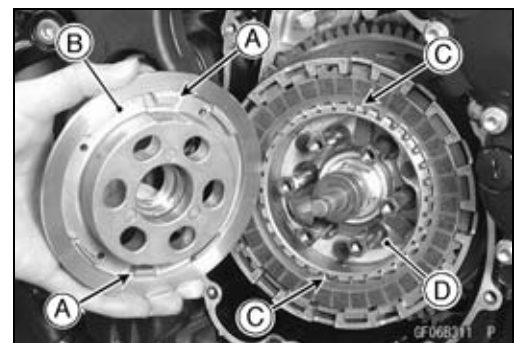

**Spring Plate Free Play Measurement**

Insufficient clutch free play will cause the engine braking effect to be more sudden, resulting in rear wheel hop. On the other hand, if the free play is excessive, the clutch lever may feel “spongy” or pulsate when pulled.

- Hold an extra drive shaft in a vise and install the following clutch parts on the shaft (see Clutch Installation).

- Spacer [A]
- Needle Bearing [B]
- Sleeve [C]
- Clutch Housing [D]
- Spacer [E]
- Clutch Hub [F]
- Sub Clutch Hub [G]
- Friction Plates (36 lining blocks) [H]
- Steel Plates [I]
- Spring Seat [J]
- Spring [K]
- Friction Plates (48 lining blocks) [L]
- Spring Plate [M]

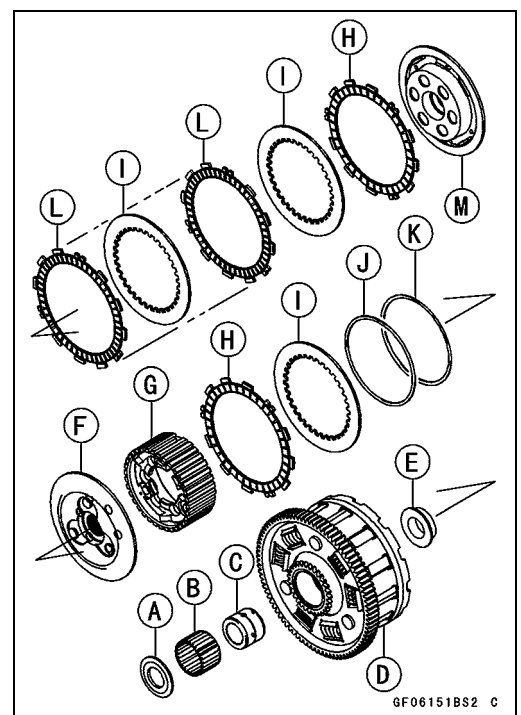

## 6-14 CLUTCH

### Clutch

- Engage the clutch hub with the sub clutch hub.
- To measure the free play, set a dial gauge [A] against the raised center [B] of the clutch spring plate.
- Move the clutch housing gear back and forth [C]. The difference between the highest and lowest gauge readings is the amount of free play.  
Drive Shaft [D]
- Measure the spring plate free play.

#### Spring Plate Free Play

Usable Range: 0.05 ~ 0.70 mm (0.002 ~ 0.028 in.)

- ★ If the free play is not within the usable range, change all of the friction plate and measure the free play again.
- ★ If the free play is not within the usable range, adjust the free play (see Spring Plate Free Play Adjustment).

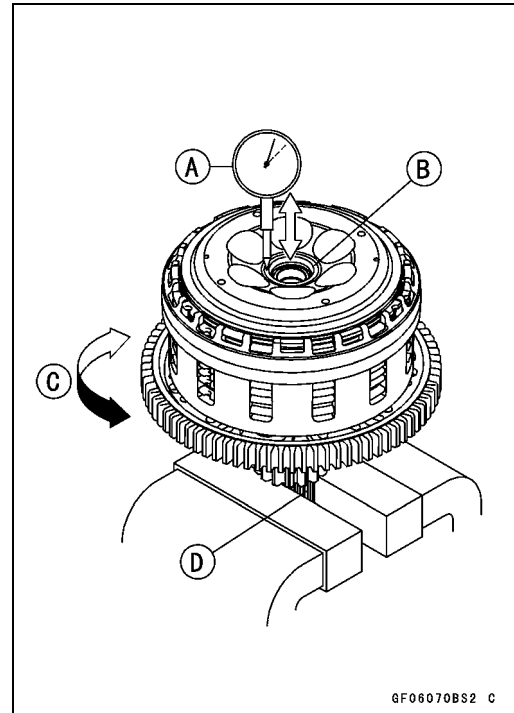

### Spring Plate Free Play Adjustment

#### NOTE

- The free play adjustment is performed by replacing the steel plate(s).
- Measure the clutch spring plate free play (see Clutch Spring Plate Free Play Measurement), and then replace the steel plate(s) which brings the free play within the usable range.

#### Spring Plate Free Play

Usable Range: 0.05 ~ 0.70 mm (0.002 ~ 0.028 in.)

- Replace the following steel plate(s).

Thickness	Part Number
2.3 mm (0.090 in.)	13089-0008
2.6 mm (0.102 in.) (STD)	13089-0009
2.9 mm (0.114 in.)	13089-1093

#### NOTE

- Do not use the steel plate of 2.3 mm (0.090 in.) and 2.9 mm (0.114 in.) thickness at the same time.



**Clutch**

**Clutch Plate Assembly Length (Reference Information)**

- Assemble the following parts.

- Clutch Hub [A]
- Spring Seat [B]
- Spring [C]
- Sub Clutch Hub [D]
- Sub Clutch Hub Bolts [E]
- New Friction Plates [F]
- Steel Plates [G]
- Spring Plate [H]
- Clutch Springs [I]
- Clutch Spring Holders [J]
- Clutch Spring Bolts [K]

**Torque - Clutch Spring Bolts: 8.8 N·m (0.90 kgf·m, 78 in·lb)**

- Measure the clutch plate assembly length [L].

**Clutch Plate Assembly Length (Reference)**  
**40.6 mm (1.60 in.)**

**NOTE**

- The length of the clutch plate assembly changes by the steel plate thickness.

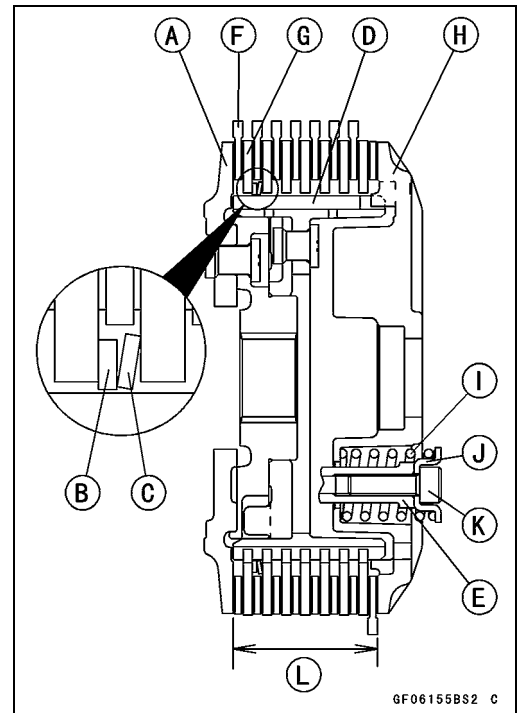

**Clutch Plate, Wear, Damage Inspection**

- Visually inspect the friction and steel plates for signs of seizure, overheating (discoloration), or uneven wear.
- Measure the thickness of each friction plate [A] at several points.
- ★ If any plates show signs of damage, or if they have worn past the service limit, replace them with new ones.

**Friction Plate Thickness**

**Standard: 2.72 ~ 2.88 mm (0.107 ~ 0.113 in.)**  
**Service Limit: 2.5 mm (0.098 in.)**

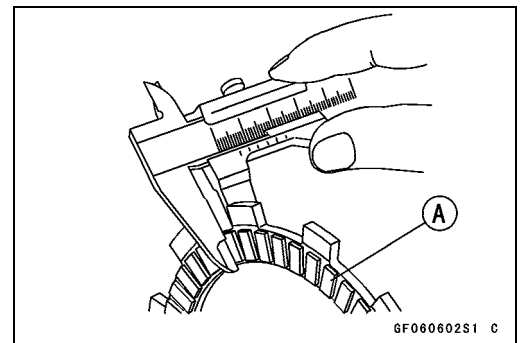

**Clutch Plate Warp Inspection**

- Place each friction plate or steel plate on a surface plate and measure the gap between the surface plate [A] and each friction plate or steel plate [B] with a thickness gauge [C]. The gap is the amount of friction or steel plate warp.
- ★ If any plate is warped over the service limit, replace it with a new one.

**Friction and Steel Plate Warp**

**Standard: 0.15 mm (0.006 in.) or less**  
**Service Limit: 0.3 mm (0.012 in.)**

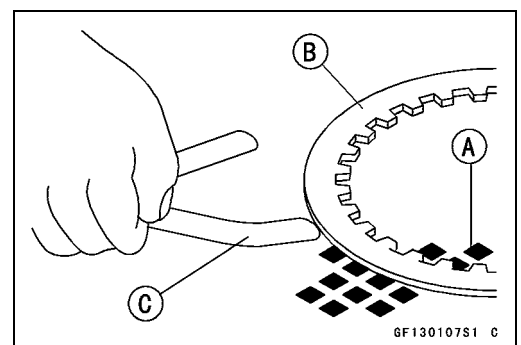

## 6-16 CLUTCH

### Clutch

#### **Clutch Spring Free Length Measurement**

- Measure the free length of the clutch springs [A].
- ★ If any spring is shorter than the service limit, it must be replaced.

#### **Clutch Spring Free Length**

Standard: 41.6 mm (1.64 in.)

Service Limit: 40.1 mm (1.58 in.)

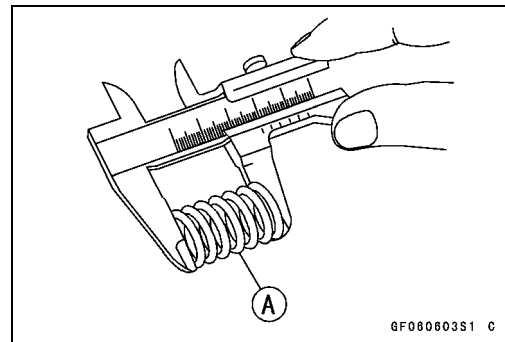

#### **Damper Cam Inspection**

- Remove the clutch (see Clutch Removal in this chapter).
- Visually inspect the damper cam [A], cam follower [B], and the torque limiter spring [C].
- Replace the part if it appears damaged.

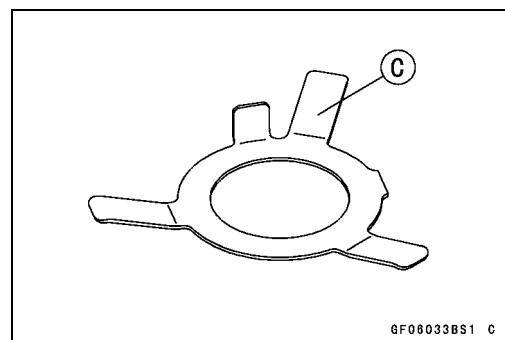
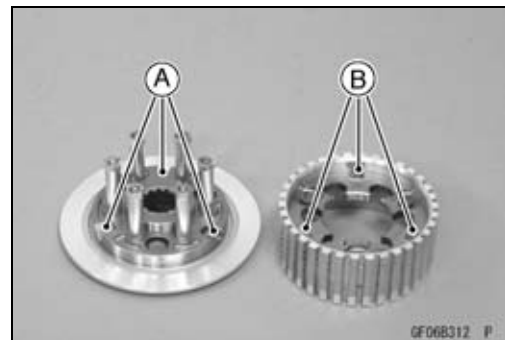

# Engine Lubrication System

## Table of Contents

Exploded View .....	7-2
Specifications .....	7-4
Special Tools and Sealant .....	7-5
Engine Oil Flow Chart.....	7-6
Engine Oil and Oil Filter.....	7-8
Oil Level Inspection.....	7-8
Engine Oil Change.....	7-8
Oil Filter Replacement .....	7-8
Oil Pan.....	7-9
Oil Pan Removal .....	7-9
Oil Pan Installation.....	7-9
Oil Pressure Relief Valve.....	7-11
Oil Pressure Relief Valve Removal .....	7-11
Oil Pressure Relief Valve Installation .....	7-11
Oil Pressure Relief Valve Inspection.....	7-12
Oil Pump.....	7-13
Oil Pump Removal .....	7-13
Oil Pump Installation .....	7-14
Oil Pump Gear Removal.....	7-15
Oil Pump Gear Installation.....	7-15
Oil Pump Gear Shaft Removal.....	7-16
Oil Pump Gear Shaft Installation.....	7-16
Oil Cooler.....	7-17
Oil Cooler Removal.....	7-17
Oil Cooler Installation.....	7-17
Oil Cooler/Oil Filter Case Removal .....	7-18
Oil Cooler/Oil Filter Case Installation .....	7-19
Oil Pressure Measurement.....	7-20
Oil Pressure Measurement .....	7-20
Oil Pressure Switch .....	7-21
Oil Pressure Switch Removal .....	7-21
Oil Pressure Switch Installation .....	7-21

# 7-2 ENGINE LUBRICATION SYSTEM

## Exploded View

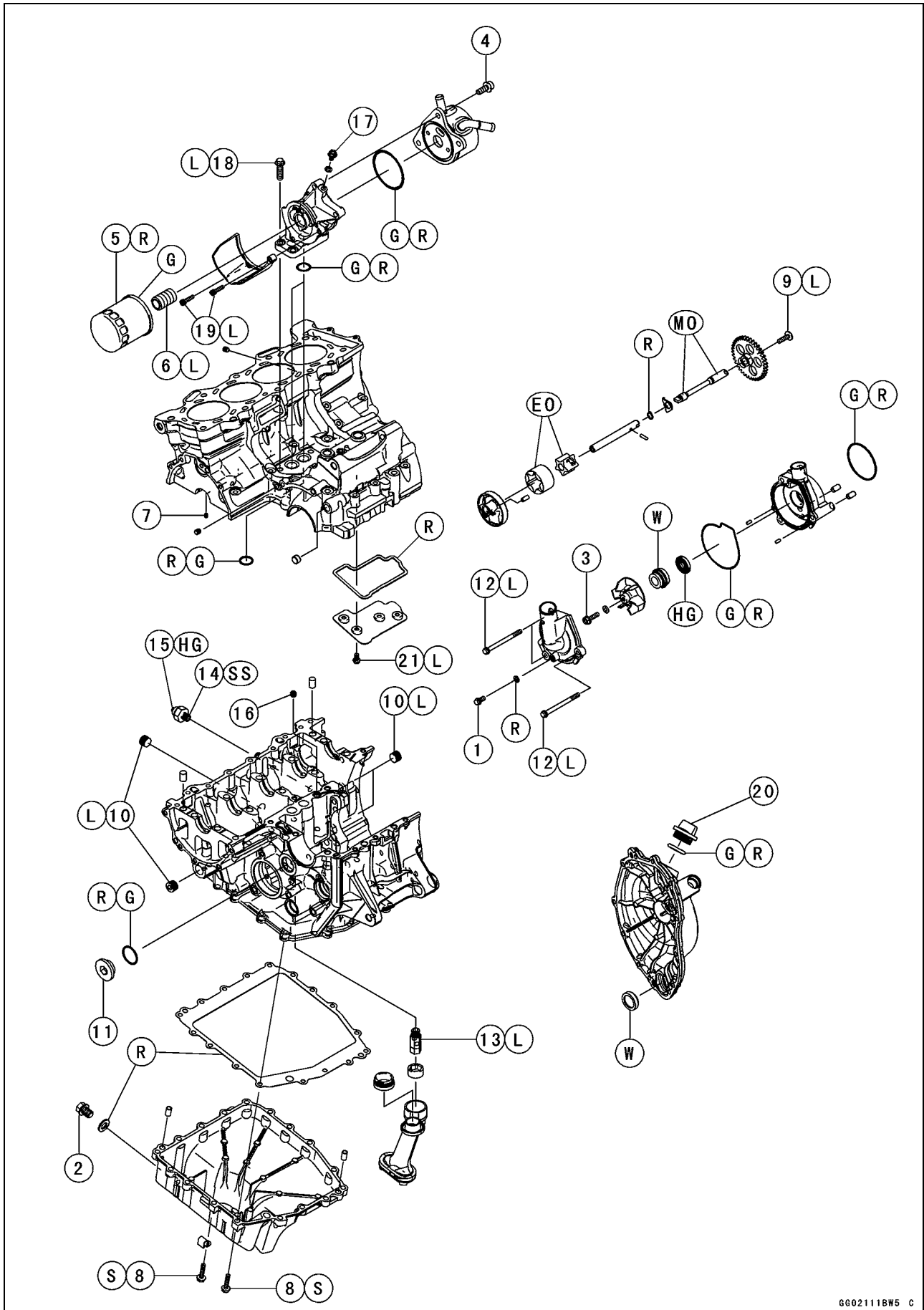

## ENGINE LUBRICATION SYSTEM 7-3

### Exploded View

No.	Fastener	Torque			Remarks
		N-m	kgf-m	ft-lb	
1	Coolant Drain Bolt (Water Pump)	8.8	0.90	78 in-lb	
2	Engine Oil Drain Bolt	29	3.0	22	
3	Impeller Bolt	9.8	1.0	87 in-lb	
4	Oil Cooler Mounting Bolts	20	2.0	15	
5	Oil Filter	31	3.2	23	G, R
6	Oil Filter Holder Bolt	25	2.5	18	L
7	Piston Oil Nozzles	2.9	0.30	26 in-lb	
8	Oil Pan Bolts	9.8	1.0	87 in-lb	S
9	Oil Pump Gear Bolt	9.8	1.0	87 in-lb	L
10	Oil Passage Plugs (Taper)	20	2.0	15	L
11	Oil Passage Plug (Left Side)	17	1.7	12	
12	Water Pump Cover Bolts	12	1.2	106 in-lb	L
13	Oil Pressure Relief Valve	15	1.5	11	L
14	Oil Pressure Switch	15	1.5	11	SS
15	Oil Pressure Switch Terminal Bolt	–	–	–	Hand-tighten
16	Oil Passage Nozzle	4.9	0.50	43 in-lb	
17	Air Bleed Bolt	9.8	1.0	87 in-lb	
18	Oil Cooler/Oil Filter Case Mounting Bolts	20	2.0	15	L
19	Oil Filter Guard Bolts	4.0	0.41	35 in-lb	L
20	Oil Filler Cap	2.0	0.20	17 in-lb	
21	Breather Plate Bolts	9.8	1.0	87 in-lb	L

EO: Apply engine oil.

G: Apply grease.

HG: Apply high-temperature grease.

L: Apply a non-permanent locking agent.

MO: Apply molybdenum disulfide oil solution.

(mixture of the engine oil and molybdenum disulfide grease in a weight ratio 10 : 1)

R: Replacement Parts

S: Follow the specified tightening sequence.

SS: Apply silicone sealant.

W: Apply water.

## 7-4 ENGINE LUBRICATION SYSTEM

### Specifications

Item	Standard
<b>Engine Oil</b> Type Viscosity Capacity Level	API SE, SF or SG API SH, SJ or SL with JASO MA SAE 10W-40 2.9 L (3.1 US qt) (when filter is not removed) 3.2 L (3.4 US qt) (when filter is removed) 3.8 L (4.0 US qt) (when engine is completely dry) Between upper and lower level lines
<b>Oil Pressure Measurement</b> Oil Pressure	96 ~ 126 kPa (0.98 ~ 1.28 kgf/cm <sup>2</sup> , 14 ~ 18 psi) at 4 000 r/min (rpm), Oil Temperature 90°C (194°F)

## Special Tools and Sealant

**Outside Circlip Pliers:**  
**57001-144**

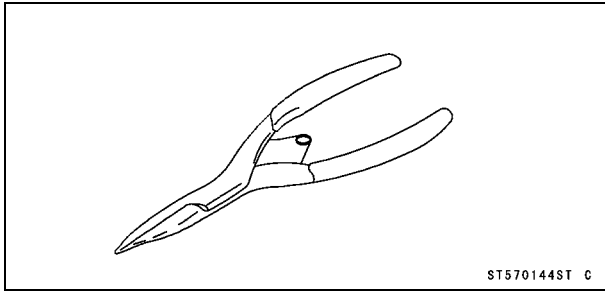

**Oil Pressure Gauge Adapter, PT3/8:**  
**57001-1233**

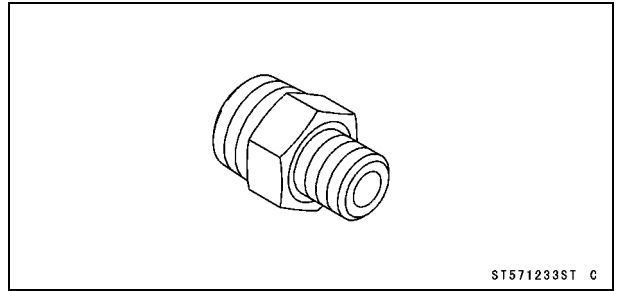

**Oil Pressure Gauge, 10 kgf/cm<sup>2</sup>:**  
**57001-164**

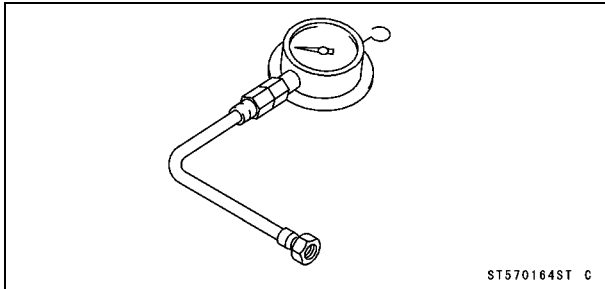

**Kawasaki Bond (Silicone Sealant):**  
**56019-120**

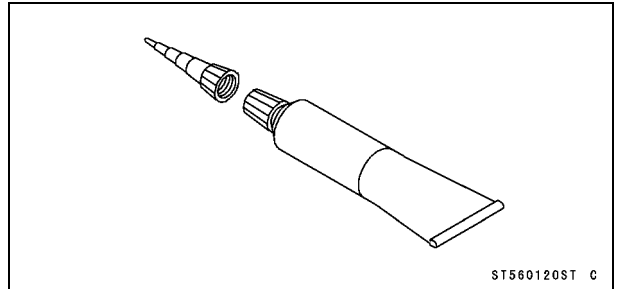

# 7-6 ENGINE LUBRICATION SYSTEM

## Engine Oil Flow Chart

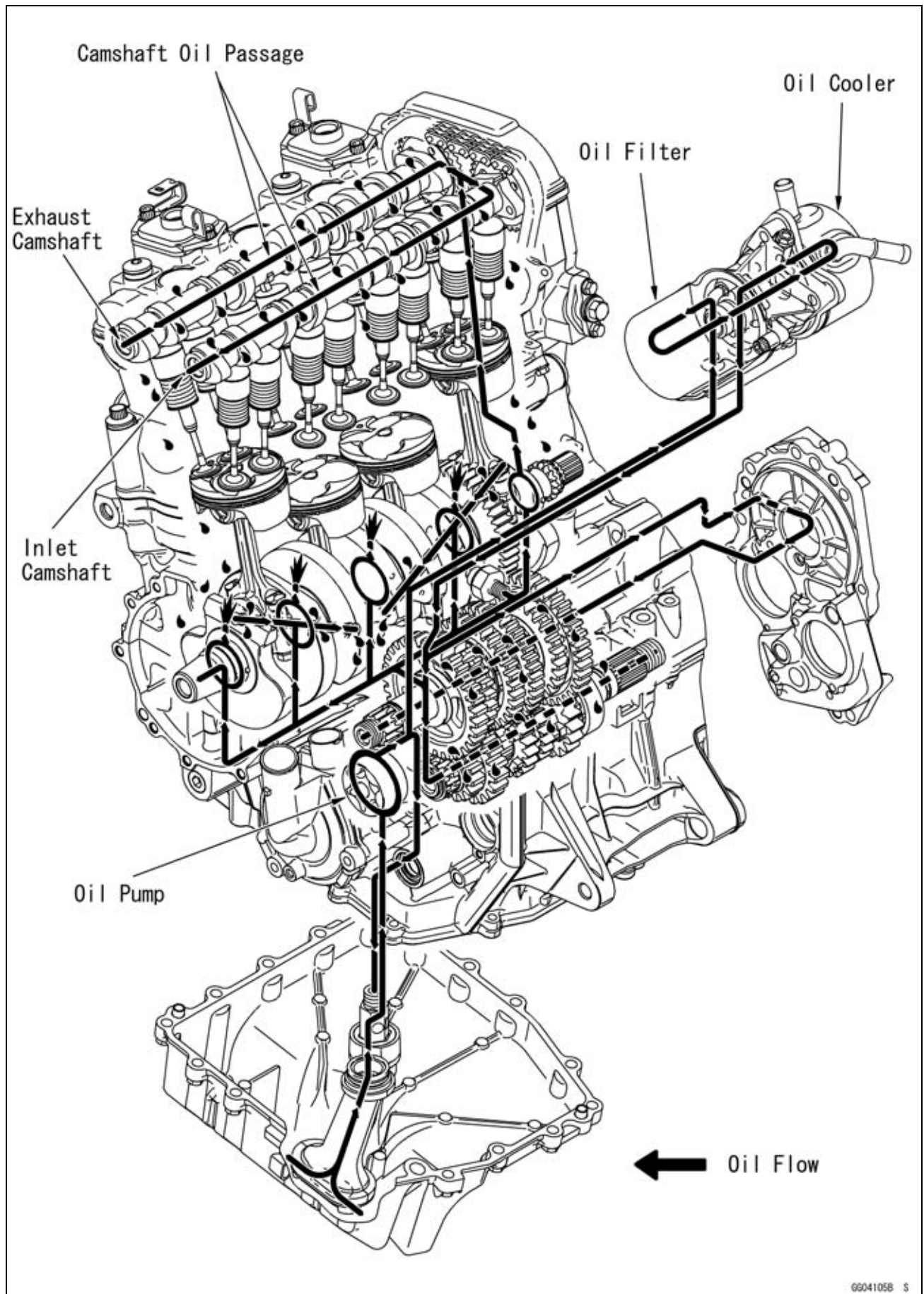



Engine Oil Flow Chart

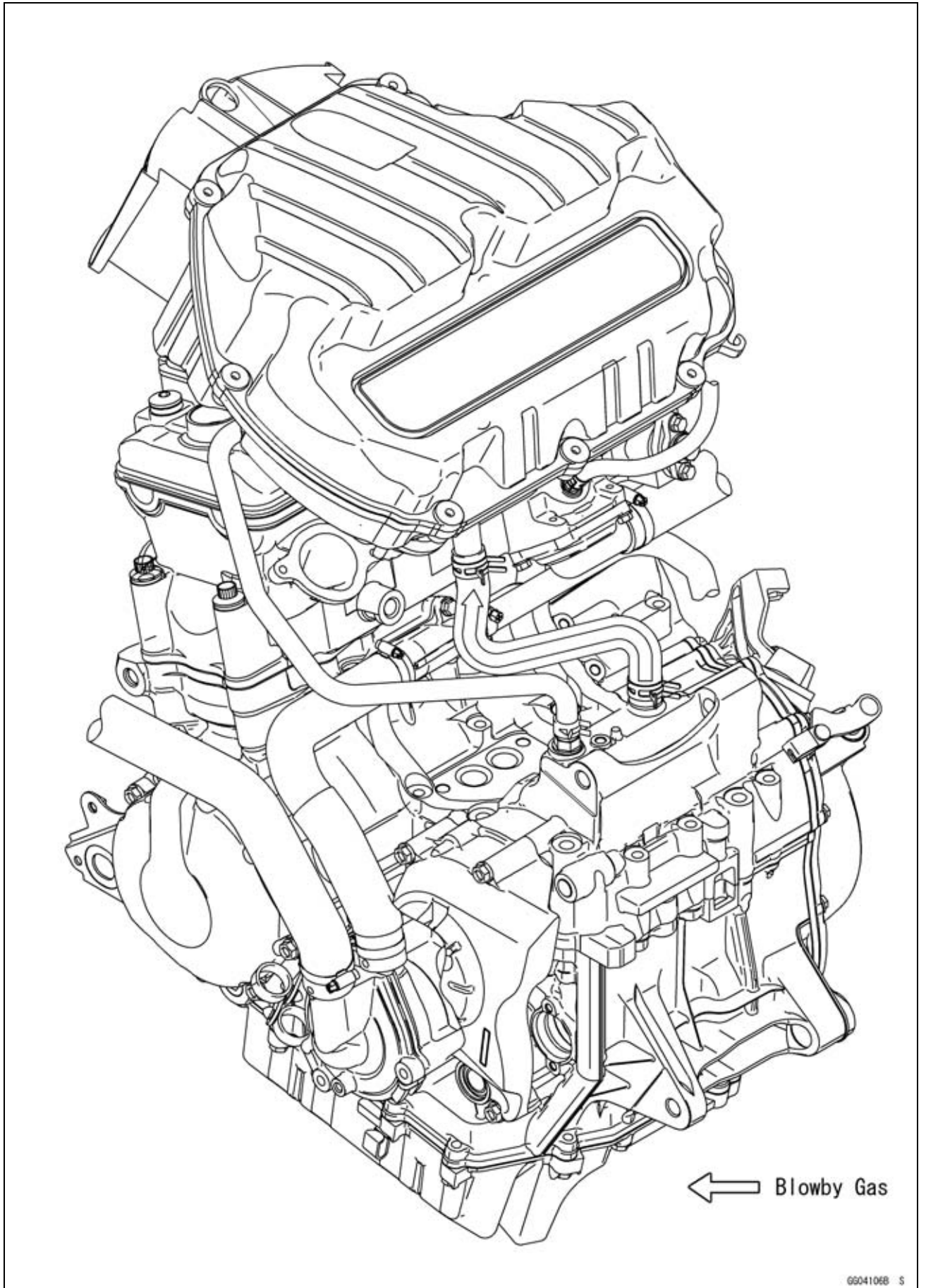

## 7-8 ENGINE LUBRICATION SYSTEM

### Engine Oil and Oil Filter

#### **⚠ WARNING**

Motorcycle operation with insufficient, deteriorated, or contaminated engine oil will cause accelerated wear and may result in engine or transmission seizure, accident, and injury.

#### **Oil Level Inspection**

- Check that the engine oil level is between the upper [A] and lower [B] levels in the gauge.

#### **NOTE**

- Situate the motorcycle so that it is perpendicular to the ground.
- If the motorcycle has just been used, wait several minutes for all the oil to drain down.
- If the oil has just been changed, start the engine and run it for several minutes at idle speed. This fills the oil filter with oil. Stop the engine, then wait several minutes until the oil settles.

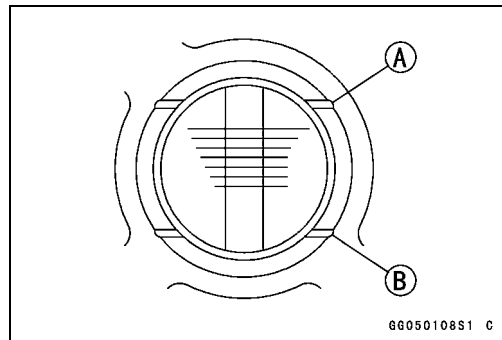

#### **CAUTION**

Racing the engine before the oil reaches every part can cause engine seizure.

If the engine oil gets extremely low or if the oil pump or oil passages clog up or otherwise do not function properly, the warning indicator light and oil pressure warning symbol will blink. If this blink stays on when the engine is running above idle speed, stop the engine immediately and find the cause.

- ★ If the oil level is too high, remove the excess oil, using a syringe or some other suitable device.
- ★ If the oil level is too low, add the correct amount of oil through the oil filler opening. Use the same type and make of oil that is already in the engine.

#### **NOTE**

- If the engine oil type and make are unknown, use any brand of the specified oil to top off the level in preference to running the engine with the oil level low. Then at your earliest convenience, change the oil completely.

#### **Engine Oil Change**

- Refer to the Engine Oil Change in the Periodic Maintenance chapter.

#### **Oil Filter Replacement**

- Refer to the Oil Filter Replacement in the Periodic Maintenance chapter.

## Oil Pan

### Oil Pan Removal

- Drain the engine oil (see Engine Oil Change in the Periodic Maintenance chapter).
- Remove:
  - Front Exhaust Pipe (see Front Exhaust Pipe Removal in the Engine Top End chapter)
  - Oil Pan Bolts [A]
  - Clamp [B]
  - Oil Pan [C]

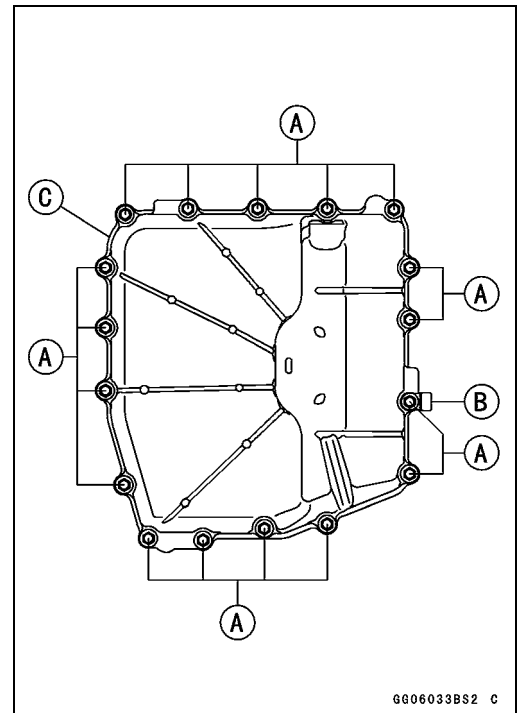

### Oil Pan Installation

- Replace the oil pan gasket [A] with a new one.
- Install the dowel pins [B].
- Install the clamp [C] as shown.
  - Rear View [D]

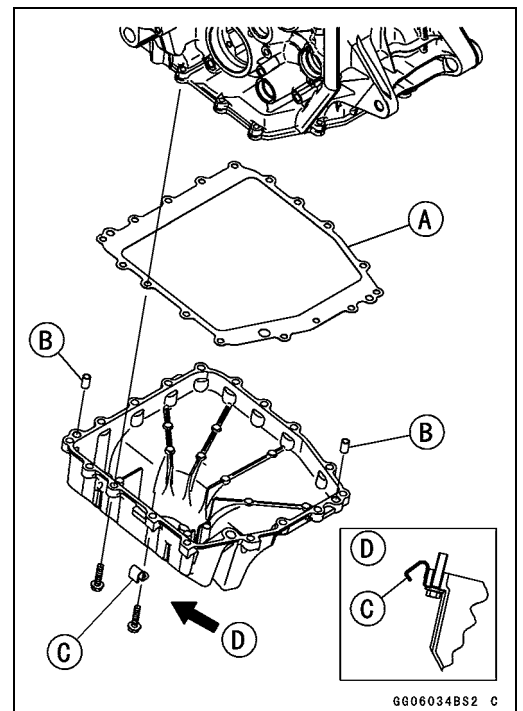

## 7-10 ENGINE LUBRICATION SYSTEM

### Oil Pan

- Tighten the oil pan bolts as shown sequence [1 ~ 20] in the figure.

**Torque - Oil Pan Bolts: 9.8 N·m (1.0 kgf·m, 87 in·lb)**

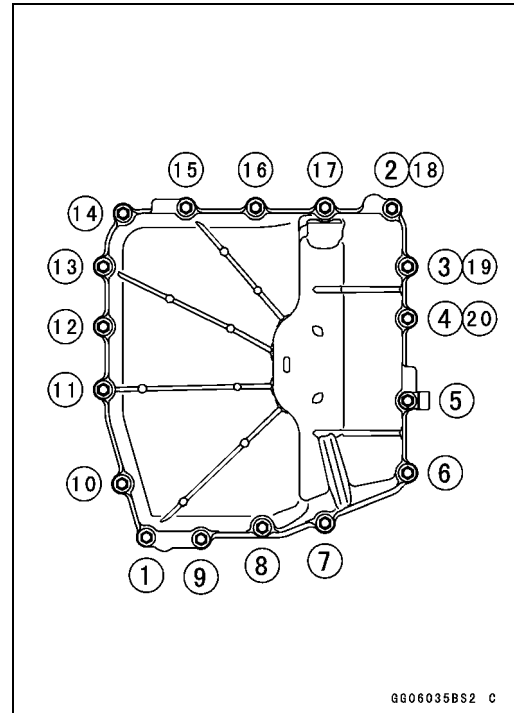

## Oil Pressure Relief Valve

### Oil Pressure Relief Valve Removal

- Remove:
  - Oil Pan (see Oil Pan Removal)
  - Oil Screen [A]

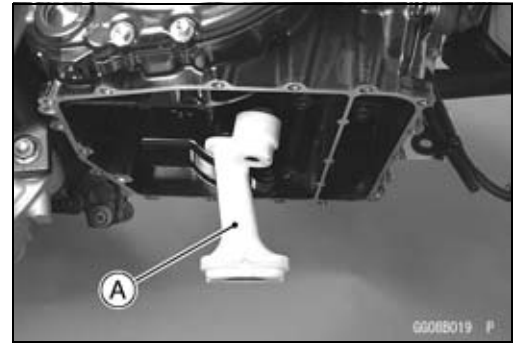

- Remove the oil pressure relief valve [A].

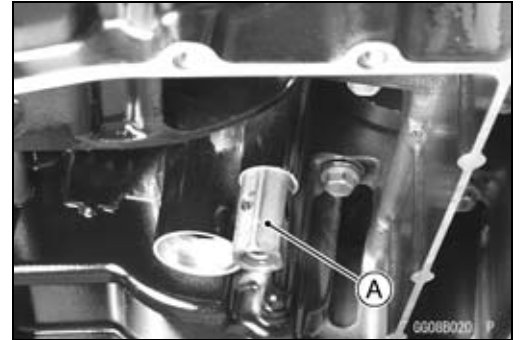

### Oil Pressure Relief Valve Installation

- Apply a non-permanent locking agent to the threads of the oil pressure relief valve [A], and tighten it.

**CAUTION**

**Do not apply too much non-permanent locking agent to the threads. This may block the oil passage.**

**Torque - Oil Pressure Relief Valve: 15 N·m (1.5 kgf·m, 11 ft·lb)**

- Clean the oil screen [B].
- Install the O-ring [C] and damper [D] to the oil screen.
- Install the oil screen so that the crankcase rib [E] and relief valve fits the oil screen.
- Install the oil pan (see Oil Pan Installation).

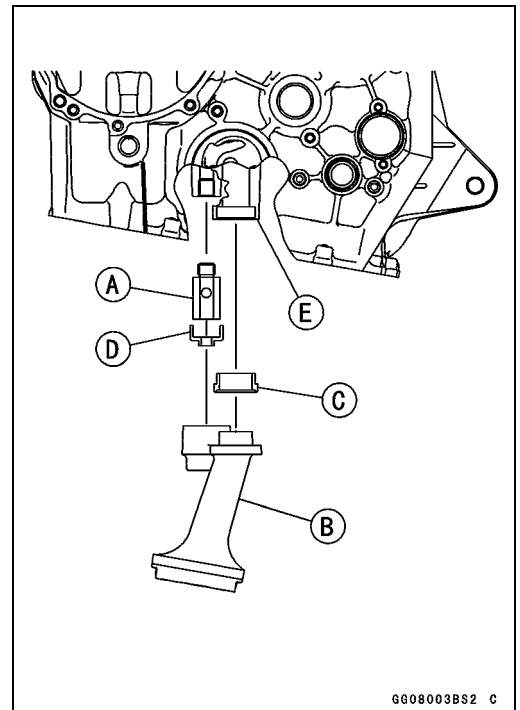

## 7-12 ENGINE LUBRICATION SYSTEM

### Oil Pressure Relief Valve

#### **Oil Pressure Relief Valve Inspection**

- Remove the oil pressure relief valve (see Oil Pressure Relief Valve Removal).
- Check to see if the valve [A] slides smoothly when pushing it in with a wooden or other soft rod, and see if it comes back to its seat by spring [B] pressure.

#### **NOTE**

○ *Inspect the valve in its assembled state. Disassembly and assembly may change the valve performance.*

- ★ If any rough spots are found during above inspection, wash the valve clean with a high-flash point solvent and blow out any foreign particles that may be in the valve with compressed air.

#### **⚠ WARNING**

**Clean the oil pressure relief valve in a well-ventilated area, and take care that there is no spark or flame anywhere near the working area. Because of the danger of highly flammable liquids, do not use gasoline or low-flash point solvent.**

- ★ If cleaning does not solve the problem, replace the oil pressure relief valve as an assembly. The oil pressure relief valve is precision made with no allowance for replacement of individual parts.

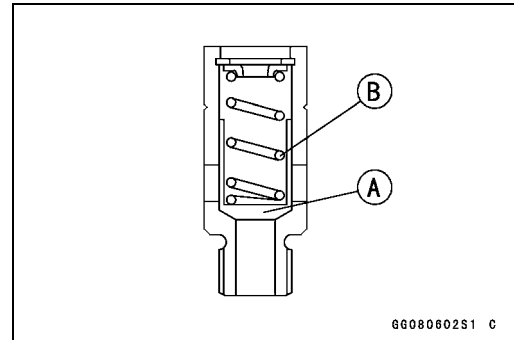

**Oil Pump**

**Oil Pump Removal**

- Drain:
  - Coolant (see Coolant Change in the Periodic Maintenance chapter)
  - Engine Oil (see Engine Oil Change in the Periodic Maintenance chapter)
- Remove:
  - Water Pump Cover Bolts [A]
  - Water Pump Cover [B]
  - Water Hose [C]
- Remove:
  - Water Hose [A]
  - Impeller Bolt [B] and Washer [C]
  - Impeller [D]

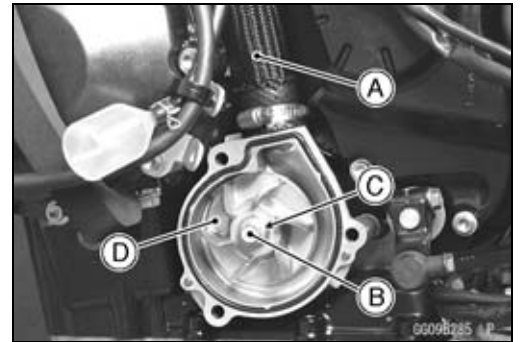
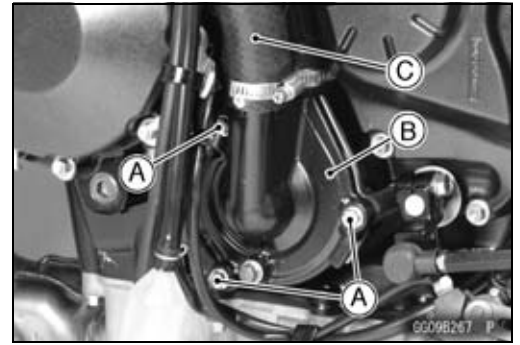

- Install the impeller bolt [A] temporary.



- Using the impeller bolt [A], pull out the oil (water) pump [B] as a assembly.
- Remove the outer rotor [C].

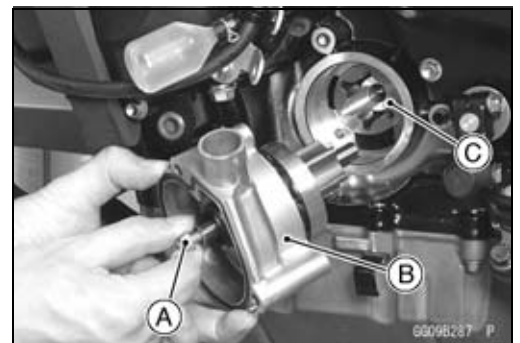

- Remove:
  - Water Pump Body [A]
  - Oil Pump Cover [B]
  - Inner Rotor [C]
  - Pin [D]
  - Oil (Water) Pump Shaft [E]

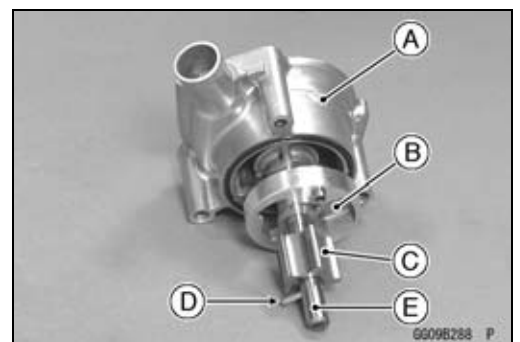

## 7-14 ENGINE LUBRICATION SYSTEM

### Oil Pump

#### Oil Pump Installation

- Install the outer rotor [A] into the crankcase.
- Install the pin [B] and inner rotor [C] to the oil (water) pump shaft [D], and install the assy.
- Turn the pump shaft so that the slot [E] in its shaft fits onto the projection [F] of the pump drive gear shaft.

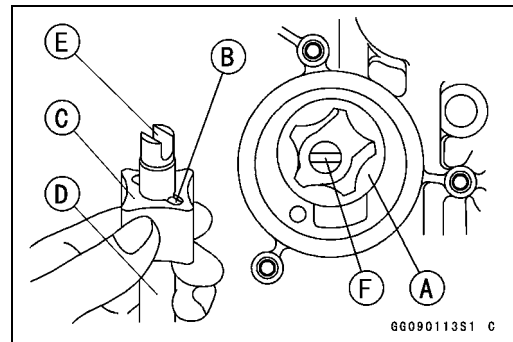

- Fit the pin [A] of the oil pump cover [B] into the hole [C] in the crankcase.

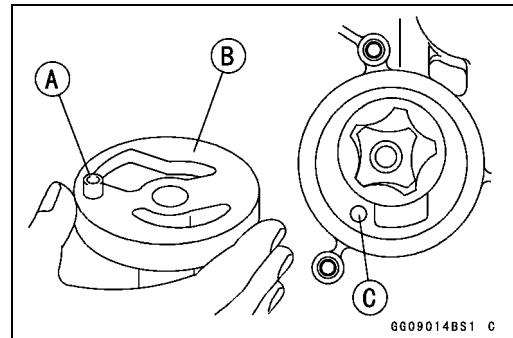

- Replace the O-ring [A] with a new one.
- Apply grease to the new O-ring.
- Install the dowel pins [B].
- Fit the pin of the crankcase into the holes [C] in the water pump body [D].

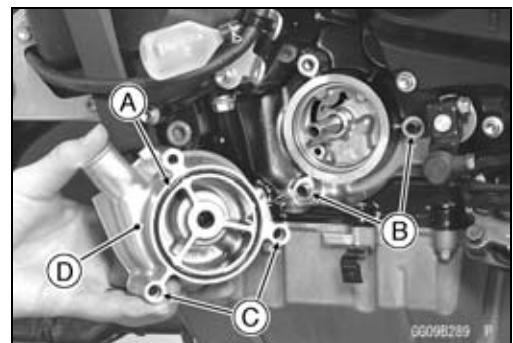

- Apply coolant to the surface of the rubber seal [A] on the impeller.
- Tighten:  
**Torque - Impeller Bolt: 9.8 N·m (1.0 kgf·m, 87 in·lb)**

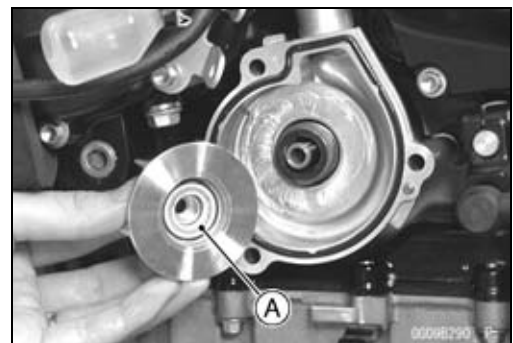

- Install the water hose [A] and hose clamp [B] as shown.  
White Mark [C]
- Tighten:  
**Torque - Water Hose Clamp Screw: 2.0 N·m (0.20 kgf·m, 17 in·lb)**

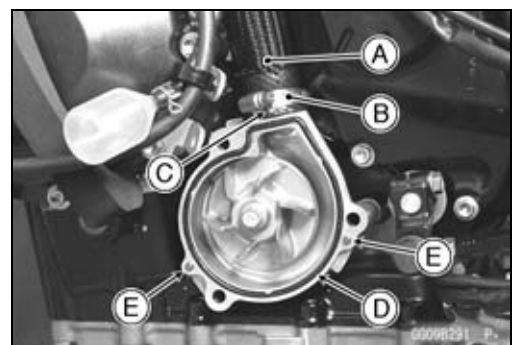

- Replace the O-ring [D] with a new one.
- Apply grease to the new O-ring.
- Install the dowel pins [E].
- Apply a non-permanent locking agent to the threads of the water pump cover bolts, and tighten them.  
**Torque - Water Pump Cover Bolts: 12 N·m (1.2 kgf·m, 106 in·lb)**



## Oil Pump

- Align the line [A] of the water pump cover and the white mark [B] of the water hose [C].
- Install the water hose clamp [D] as shown.
- Tighten:

**Torque - Water Hose Clamp Screw: 2.0 N-m (0.20 kgf-m, 17 in-lb)**

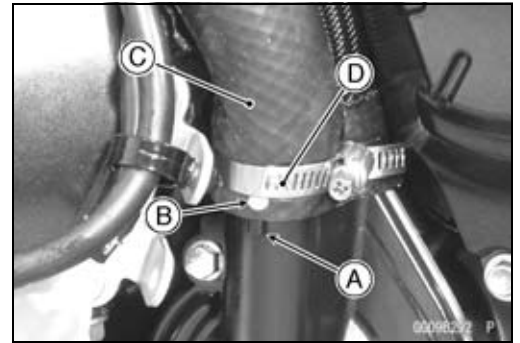

- Fill the engine with engine oil (see Engine Oil Change in the Periodic Maintenance chapter).

### NOTE

○ If the oil pump and camshaft or cylinder head were removed as a set, remove the oil cooler/oil filter case and pour the engine oil into the oil passages of the upper crankcase (see Oil Cooler/Oil Filter Case Installation).

- Fill the engine with coolant and bleed the air from the cooling system (see Coolant Change in the Periodic Maintenance chapter).

### Oil Pump Gear Removal

- Remove the clutch (see Clutch Removal in the Clutch chapter).
- Fit the suitable tool [A] into the hole of the oil passage plug [B].

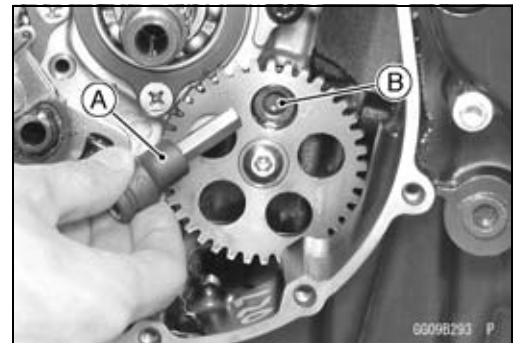

- Hold the oil pump gear [A] steady with the suitable tool [B], and remove the bolt [C].
- Remove the oil pump gear.

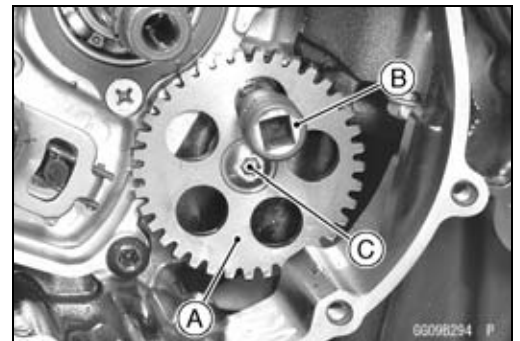

### Oil Pump Gear Installation

- Align the groove [A] of the oil pump gear to the oil pump gear shaft [B] to install the oil pump gear.
- Apply a non-permanent locking agent to the threads of the oil pump gear bolt.
- Hold the oil pump gear steady with the suitable tool, and tighten the bolt.

**Torque - Oil Pump Gear Bolt: 9.8 N-m (1.0 kgf-m, 87 in-lb)**

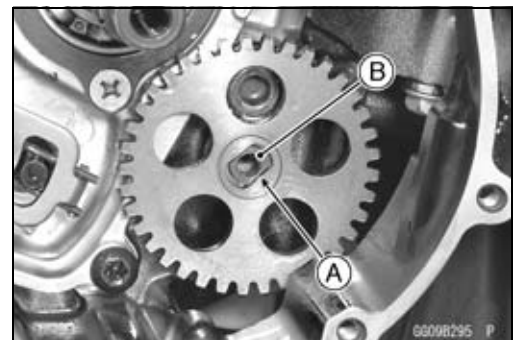

## 7-16 ENGINE LUBRICATION SYSTEM

### Oil Pump

#### ***Oil Pump Gear Shaft Removal***

- Remove:
  - Oil Pump Gear (see Oil Pump Gear Removal)
  - Oil Pan (see Oil Pan Removal)
  - Circlip [A]
  - Washer [B]
  - Oil Pump Gear Shaft [C]

**Special Tool - Outside Circlip Pliers: 57001-144**

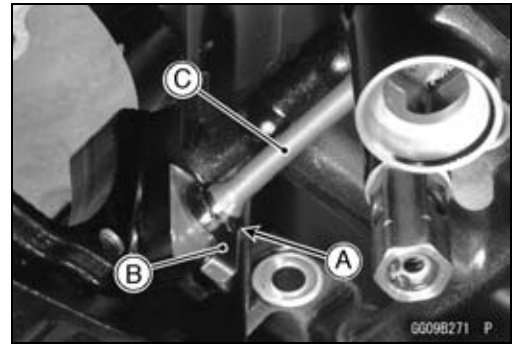

#### ***Oil Pump Gear Shaft Installation***

- Apply molybdenum disulfide oil solution to the journal portions [A] on the oil pump gear shaft.
- Install the washer [B] as shown.
- Install the new circlip [C] into the groove of the oil pump gear shaft.

**Special Tool - Outside Circlip Pliers: 57001-144**

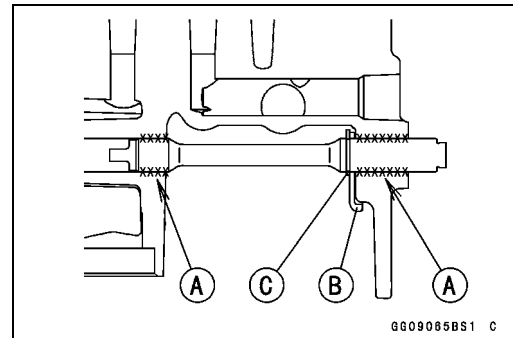

## Oil Cooler

### Oil Cooler Removal

- Drain:
  - Coolant (see Coolant Change in the Periodic Maintenance chapter)
  - Engine Oil (see Engine Oil Change in the Periodic Maintenance chapter)
- Remove:
  - Starter Motor (see Starter Motor Removal in the Electrical System chapter)
  - Clutch Cable Lower End (see Cable Removal in the Clutch chapter)
  - Clutch Cover Bolts [A]
  - Bracket [B]
  - Water Hoses [C]
  - Oil Cooler Mounting Bolts [D]
  - Oil Cooler [E]

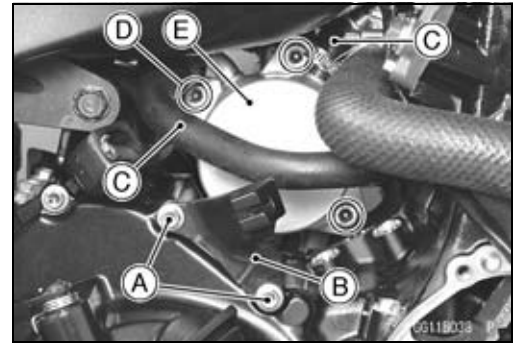

### Oil Cooler Installation

- Replace the O-ring [A] with a new one.
- Apply grease to the new O-ring.



- Install the oil cooler [A].
- Tighten:
  - Torque - Oil Cooler Mounting Bolts: 20 N-m (2.0 kgf-m, 15 ft-lb)**
- Install the water hoses [B] and hose clamps [C] as shown. Upside View [D]
- Tighten:
  - Torque - Water Hose Clamp Screws: 2.0 N-m (0.20 kgf-m, 17 in-lb)**

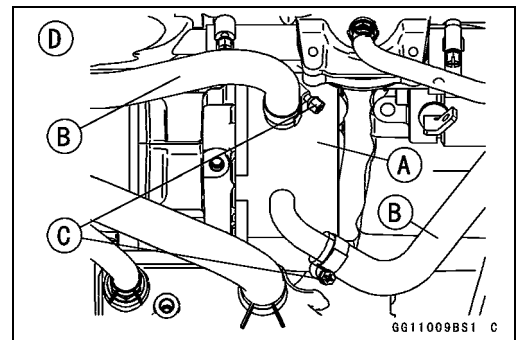

- Install the removed parts (see appropriate chapters).
- Pour:
  - Coolant (see Coolant Change in the Periodic Maintenance chapter)
  - Engine Oil (see Engine Oil Change in the Periodic Maintenance chapter)

## 7-18 ENGINE LUBRICATION SYSTEM

### Oil Cooler

#### **Oil Cooler/Oil Filter Case Removal**

- Remove:
  - Oil Filter (see Oil Filter Replacement in the Periodic Maintenance chapter)
  - Oil Cooler (see Oil Cooler Removal)
  - Bolt [A]



- Pull the oil filter guard [A] forward as shown.
- Remove:
  - Bolt [B]
  - Oil Filter Guard

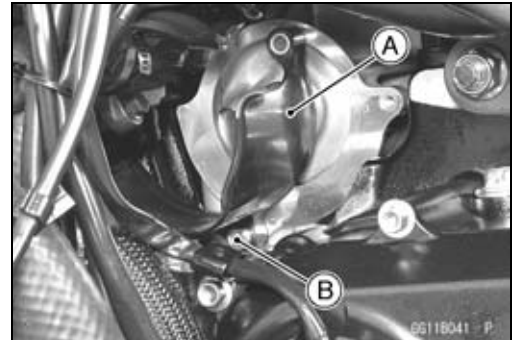

- Remove the bolts [A].



- Remove:
  - Bolts [A]
  - Oil Cooler/Oil Filter Case [B]
- Remove the oil filter holder bolt [C] as necessary.

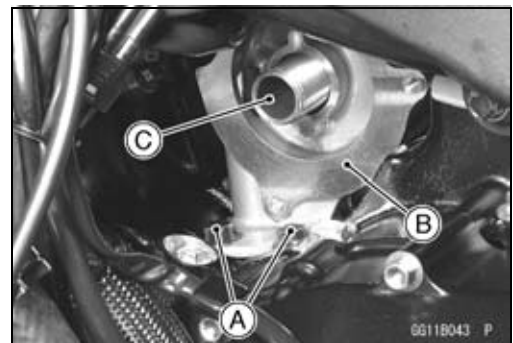

**Oil Cooler**

**Oil Cooler/Oil Filter Case Installation**

★If the crankcase was disassembled, pour the engine oil into the oil passages [A] until O-ring insert portions [B] of the upper crankcase.

**NOTE**

- Pour the engine oil into the oil passages because of quick supply of the engine oil to the cylinder head.
- The engine oil capacity of the oil passages is approximately 0.2 L (0.2 US qt). Therefore, after assembling the engine, pour the engine oil of the 3.6 L (3.8 US qt) into the filler hole on the clutch cover. The total amount of the engine oil becomes 3.8 L (4.0 US qt) of the standard (when engine is completely dry).

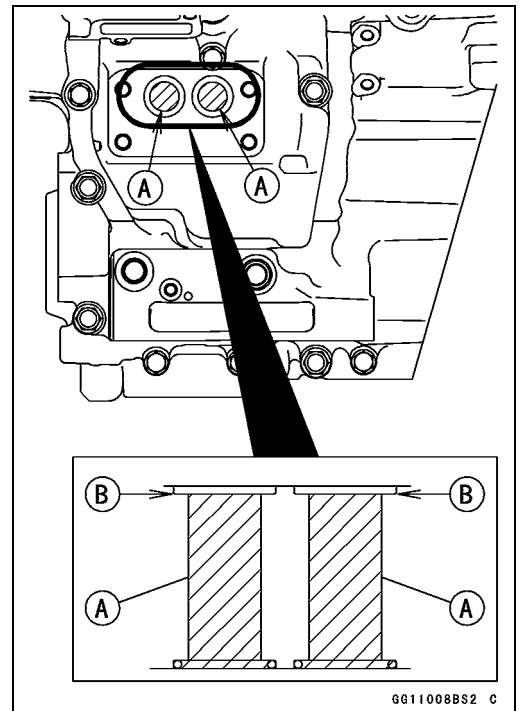

★If the oil filter holder bolt [A] was removed, install it.  
 ○Apply non-permanent locking agent to the treads of the oil filter holder bolt, and tighten it.

**Torque - Oil Filter Holder Bolt: 25 N·m (2.5 kgf·m, 18 ft·lb)**

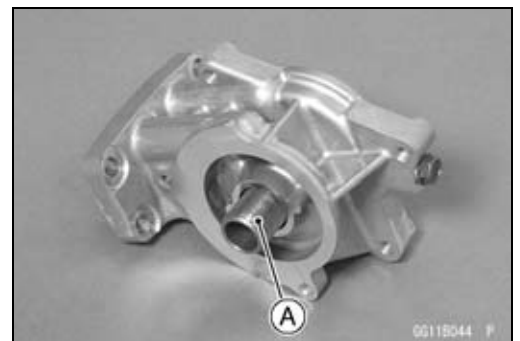

- Replace the O-rings [A] with new ones.
- Apply grease to the new O-rings.

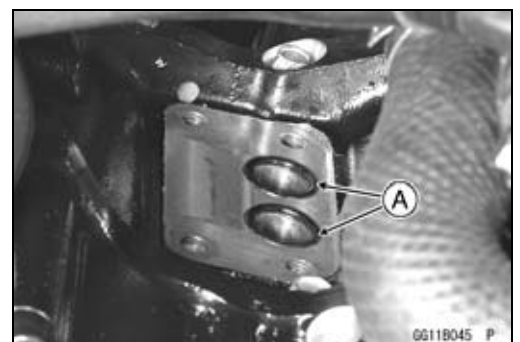

● Apply non-permanent locking agent to the treads of the oil cooler/oil filter case mounting bolts, and tighten them.

**Torque - Oil Cooler/Oil Filter Case Mounting Bolts: 20 N·m (2.0 kgf·m, 15 ft·lb)**

● Apply non-permanent locking agent to the treads of the oil filter guard bolts, and tighten them.

**Torque - Oil Filter Guard Bolts: 4.0 N·m (0.41 kgf·m, 35 in·lb)**

● Install:

- Oil Cooler (see Oil Cooler Installation)
- Oil Filter (see Oil Filter Replacement in the Periodic Maintenance chapter)

## 7-20 ENGINE LUBRICATION SYSTEM

### Oil Pressure Measurement

#### Oil Pressure Measurement

- Remove:
  - Lower Fairings (see Lower Fairing Removal in the Frame chapter)
  - Oil Passage Plug [A]

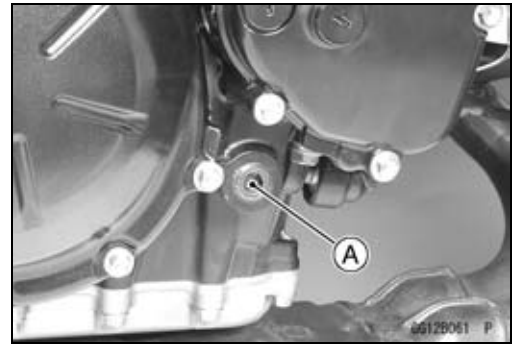

- Attach the adapter [A] and gauge [B] to the plug hole.
  - Special Tools - Oil Pressure Gauge, 10 kgf/cm<sup>2</sup>: 57001-164**
  - Oil Pressure Gauge Adapter, PT3/8: 57001-1233**



- Start the engine and warm up the engine.
- Run the engine at the specified speed, and read the oil pressure gauge.
- ★ If the oil pressure is much lower than the standard, check the oil pump, relief valve, and/or crankshaft bearing insert wear.
- ★ If the reading is much higher than the standard, check the oil passages for clogging.

#### Oil Pressure

**Standard:** 96 ~ 126 kPa (0.98 ~ 1.28 kgf/cm<sup>2</sup>, 14 ~ 18 psi) at 4 000 r/min (rpm), oil temperature 90°C (194°F)

- Stop the engine.
- Remove the oil pressure gauge and adapter.

#### **⚠ WARNING**

**Take care against burns from hot engine oil that will drain through the oil passage when the gauge adapter is removed.**

- Apply a non-permanent locking agent to the oil passage plug, and install it.
  - Torque - Oil Passage Plug (Taper): 20 N-m (2.0 kgf-m, 15 ft-lb)**

**Oil Pressure Switch**

**Oil Pressure Switch Removal**

- Drain the engine oil (see Engine Oil Change in the Periodic Maintenance chapter).
- Remove the right lower fairing (see Lower Fairing Removal in the Frame chapter).
- Slide out the rubber boot [A].
- Loosen the oil pressure switch terminal bolt [B], and remove the switch lead [C].
- Remove the oil pressure switch [D].

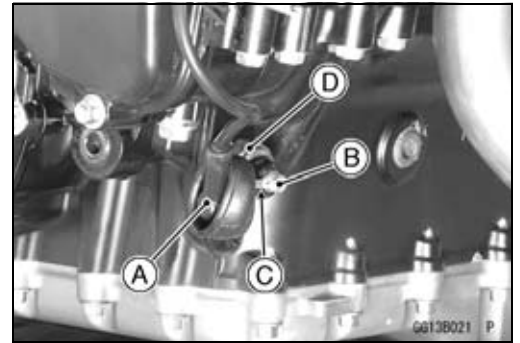

**Oil Pressure Switch Installation**

- Apply silicone sealant to the threads of the oil pressure switch [A] and tighten it.

**Sealant - Kawasaki Bond (Silicone Sealant): 56019-120**

**Torque - Oil Pressure Switch: 15 N·m (1.5 kgf·m, 11 ft·lb)**

- Install the switch lead [B] direction as shown.  
Front View [C]

- Tighten:

**Torque - Oil Pressure Switch Terminal Bolt: Hand-tighten**

- Apply high-temperature grease to the switch terminal [D].
- Slide back the rubber boot to the original position.

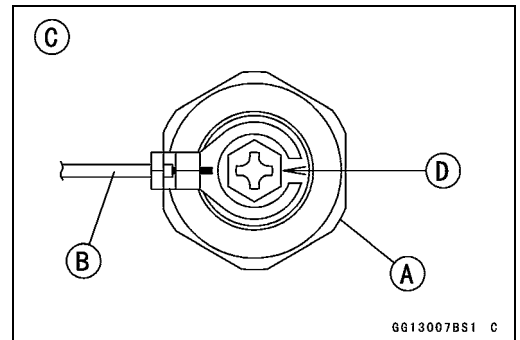

**NOTE**

- Apply a small amount grease to the terminal so that grease should not close two breather holes [A] for switch diaphragm.

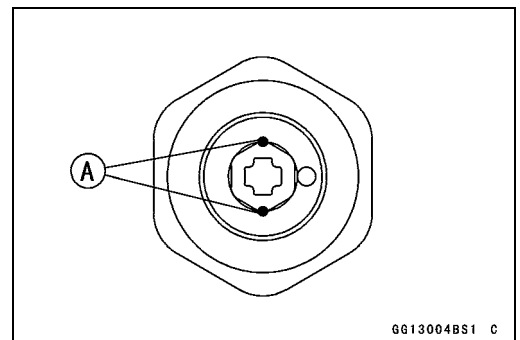





# Engine Removal/Installation

## Table of Contents

Exploded View .....	8-2
Special Tool .....	8-4
Engine Removal/Installation .....	8-5
Engine Removal.....	8-5
Engine Installation.....	8-8

# 8-2 ENGINE REMOVAL/INSTALLATION

## Exploded View

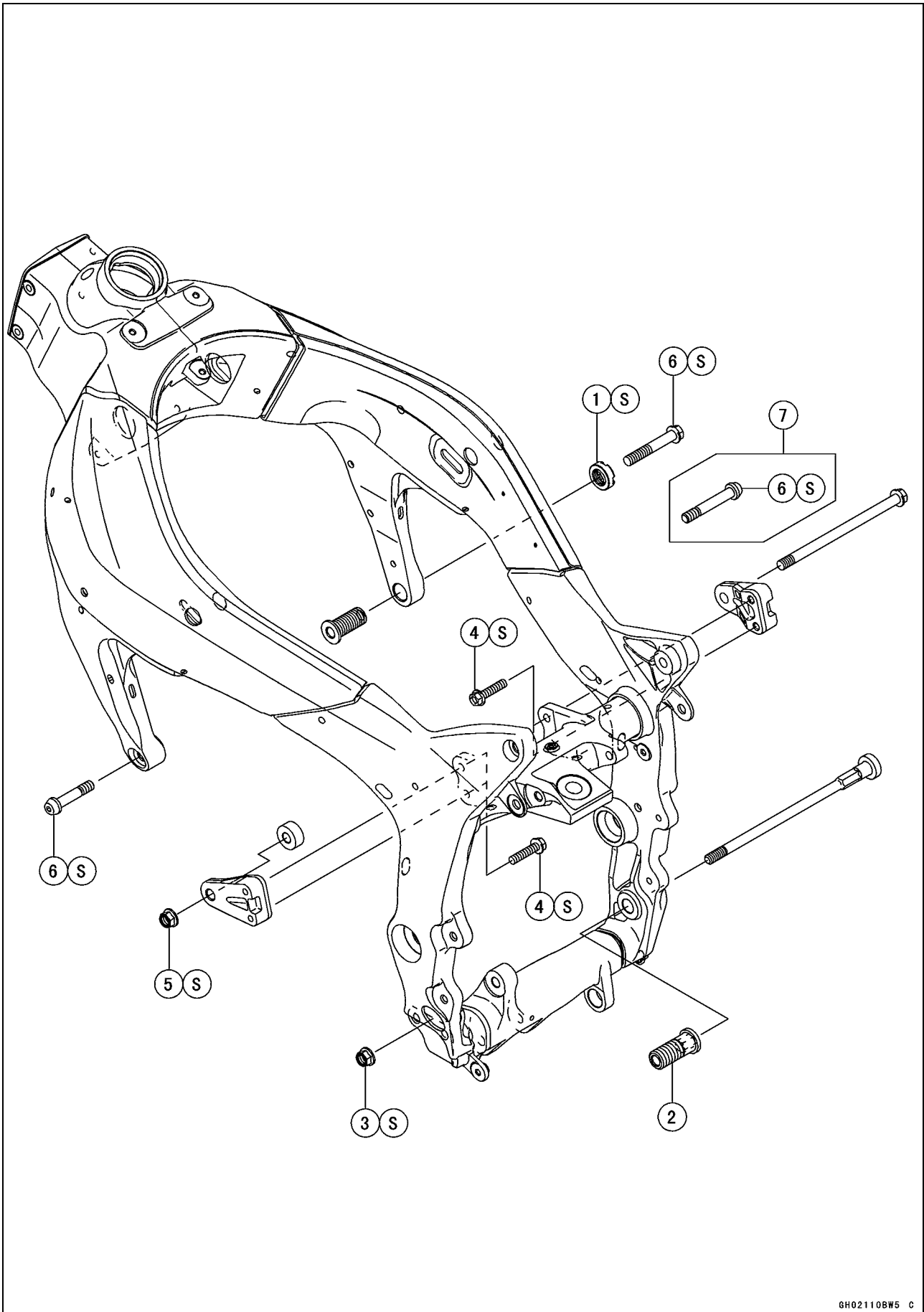

## ENGINE REMOVAL/INSTALLATION 8-3

### Exploded View

No.	Fastener	Torque			Remarks
		N·m	kgf·m	ft·lb	
1	Adjusting Collar Locknut	49	5.0	36	S
2	Adjusting Collar	9.8	1.0	87 in·lb	S
3	Lower Engine Mounting Nut	44	4.5	33	S
4	Middle Engine Mounting Bracket Bolts	25	2.5	18	S
5	Middle Engine Mounting Nut	44	4.5	33	S
6	Upper Engine Mounting Bolts	44	4.5	33	S

7. ZX600P7F

S: Follow the specified tightening sequence.

## 8-4 ENGINE REMOVAL/INSTALLATION

---

### Special Tool

---

Engine Mount Nut Wrench:

57001-1450

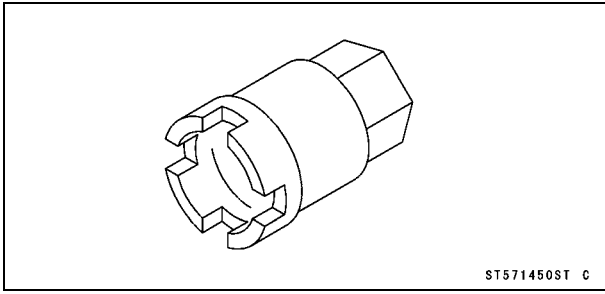

## Engine Removal/Installation

### Engine Removal

- Support the rear part of the swingarm with a stand.
- Squeeze the brake lever slowly and hold it with a band [A].

### **⚠ WARNING**

**Be sure to hold the front brake when removing the engine, or the motorcycle may fall over. It could cause an accident and injury.**

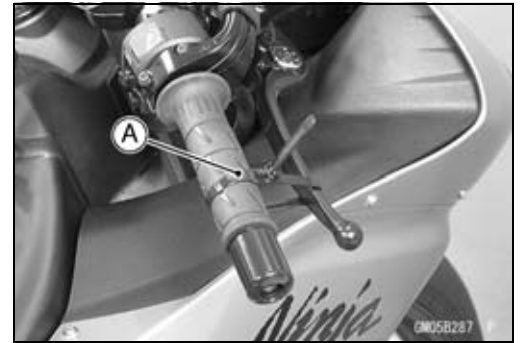

### **CAUTION**

**Be sure to hold the front brake when removing the engine, or the motorcycle may fall over. The engine or the motorcycle could be damaged.**

- Drain:
  - Engine Oil (see Engine Oil Change in the Periodic Maintenance chapter)
  - Coolant (see Coolant Change in the Periodic Maintenance chapter)
- Remove:
  - Middle Fairings (see Middle Fairing Removal in the Frame chapter)
  - Fuel Tank (see Fuel Tank Removal in the Fuel System (DFI) chapter)
  - Air Cleaner Housing (see Air Cleaner Housing Removal in the Fuel System (DFI) chapter)
  - Throttle Body Assy (see Throttle Body Assy Removal in the Fuel System (DFI) chapter)
  - Clutch Cable Lower End (see Clutch Cable Removal in the Clutch chapter)
  - Radiator (see Radiator and Radiator Fan Removal in the Cooling System chapter)
  - Exhaust Pipe (see Exhaust Pipe Removal in the Engine Top End chapter)
  - Shift Lever (see Shift Pedal Removal in the Crankshaft/Transmission chapter)
  - Drive Chain (see Engine Sprocket Removal in the Final Drive chapter)
  - Coolant Reserve Tank (see Coolant Reserve Tank Removal in the Cooling System chapter)
- Remove the heat insulation plate [A].
  - Pull out the right side of the plate to the inside of the frame.

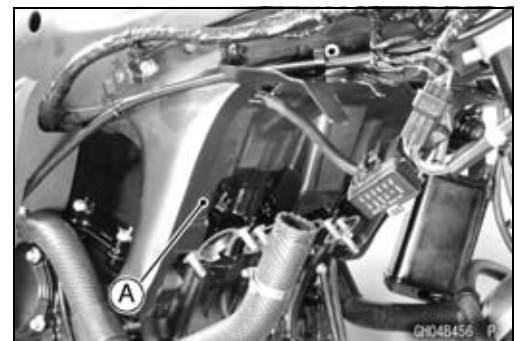

## 8-6 ENGINE REMOVAL/INSTALLATION

### Engine Removal/Installation

- Disconnect the connectors from the engine and free the wiring from the clamps.

Stick Coil Connectors [A]  
Cylinder Head Cover Ground Terminal [B]  
Air Switching Valve Connector [C]  
Camshaft Position Sensor Connector [D]

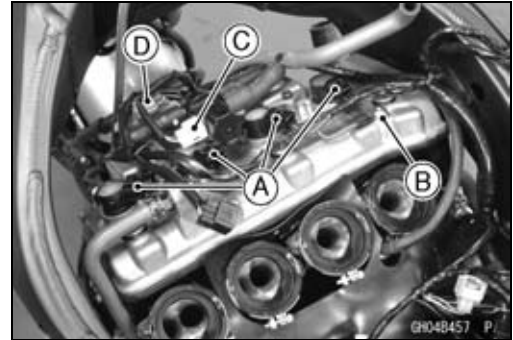

- Disconnect:
  - Alternator Lead Connector [A]
  - Rear Brake Light Switch Connector [B]
  - Gear Position Switch/Side Stand Switch Lead Connector [C]
  - Crankshaft Sensor/Oil Pressure Switch Lead Connector [D]
  - Water Temperature Sensor Connector [E]

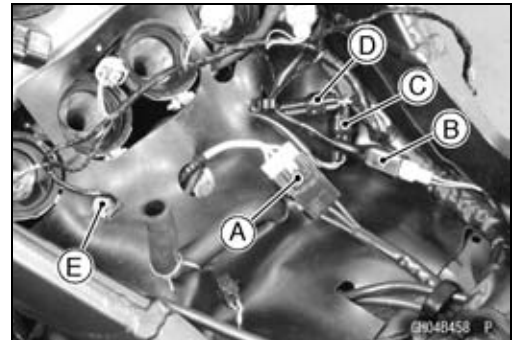

- Turn up the front side of the heat insulation rubber plate [A].

- Remove:
  - Blowby Hose [B]
  - Engine Ground Bolt [C]
  - Starter Motor Cable Bolt [D]

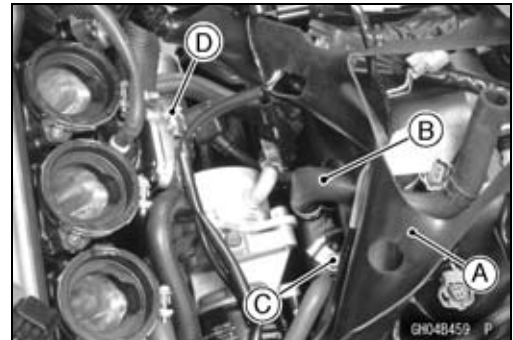

- Open the clamps [A]
- Disconnect the regulator/rectifier connector [B]

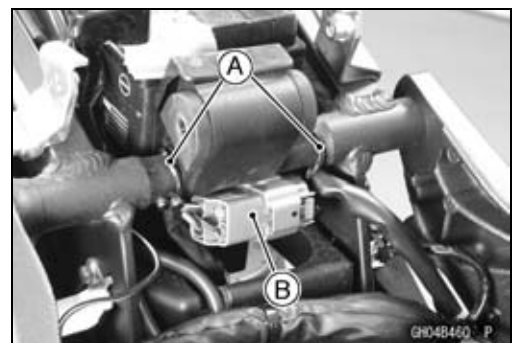

## Engine Removal/Installation

- Turn up the rear side of the heat insulation rubber plate [A].
- Loosen the middle engine mounting bracket bolts [B]

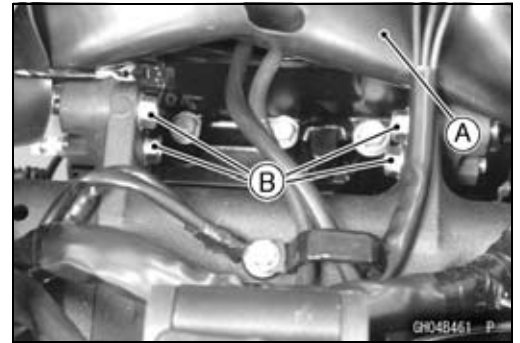

- Support the engine with a suitable stand [A].
- Put a plank [B] onto the suitable stand for engine balance.

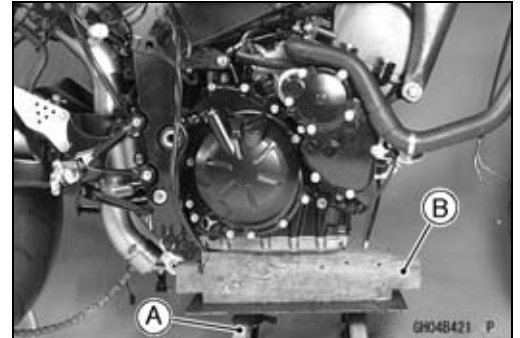

- Remove:
  - Right Upper Engine Mounting Bolt [A]
  - Left Upper Engine Mounting Bolt



- Using the nut wrench [A], loosen the locknut [B].  
**Special Tool - Engine Mount Nut Wrench: 57001-1450**

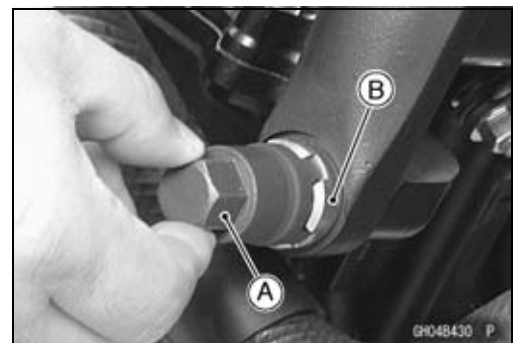

- Using the Hexagon Wrench, turn the adjusting collar [A] counterclockwise to make the gap between the engine and collar.



## 8-8 ENGINE REMOVAL/INSTALLATION

### Engine Removal/Installation

- Remove the middle and lower engine mounting nuts.
- Turn the lower mounting bolts [A] clockwise to make the gap between the collar and frame.
- Pull out the engine mounting bolts from the right side.

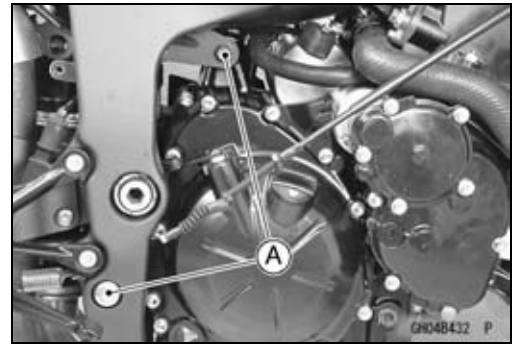

- Using the stand, take out the engine.

### Engine Installation

- Install the adjusting collar [A] to crankcase backside until end of the threads.

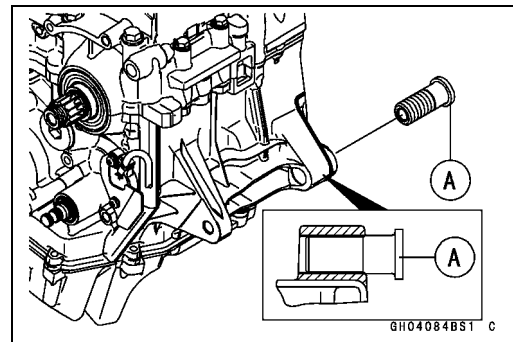

- Install the adjusting collar bolt [A] to the frame until end of the threads.

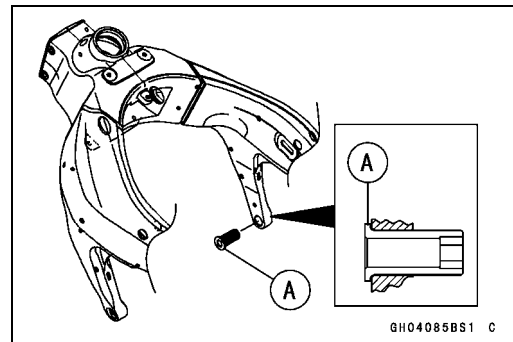

- Support the engine with a suitable stand.
- Put a plank onto the suitable stand for engine balance.



## Engine Removal/Installation

- Install the engine mounting bolts and nuts, following the specified installing sequence.
- First, install the middle engine mounting bracket [A], and tighten the bracket bolts [B] temporarily.
- Second, tighten the following bolts and nuts temporarily.
  - [C] Lower Engine Mounting Bolt and Nut
  - [D] Collar
  - [E] Middle Engine Mounting Bolt and Nut
  - [F] Left Upper Engine Mounting Bolt
  - [G] Right Upper Engine Mounting Bolt

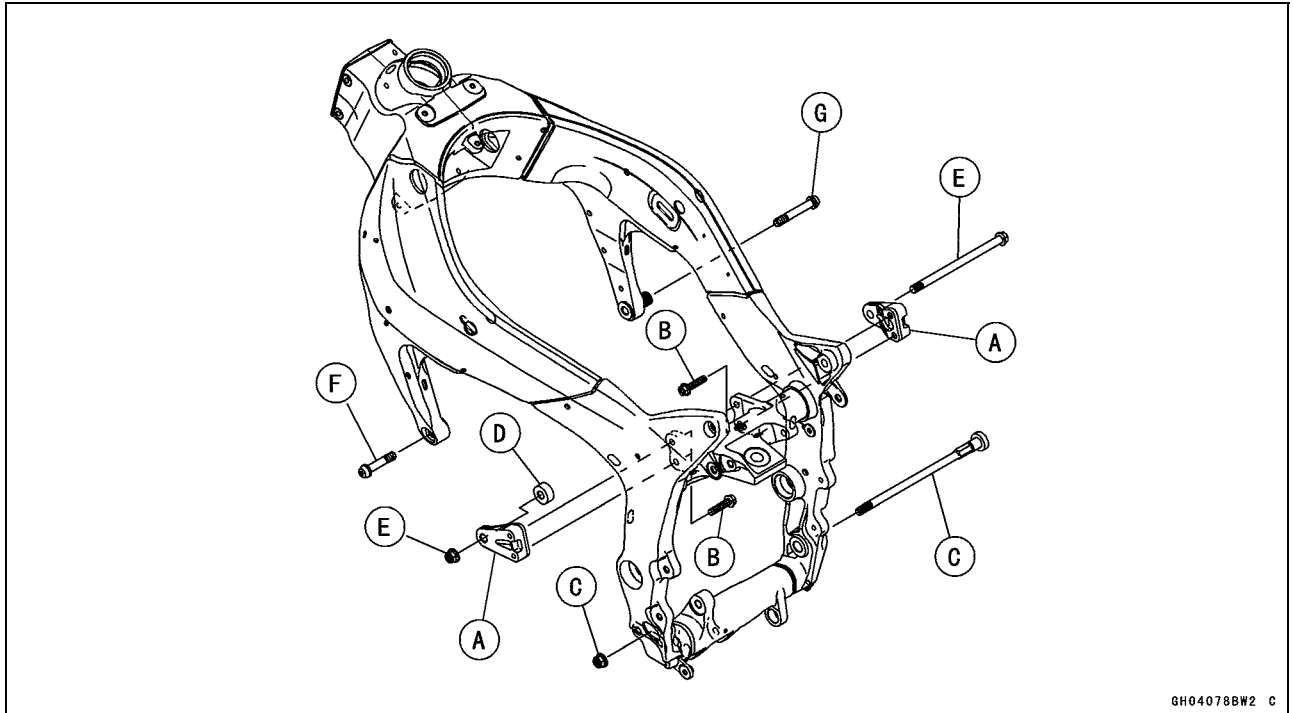

- Third, tighten the left upper engine mounting bolt [A].
  - [B] Frame
  - [C] Engine

**Torque - Left Upper Engine Mounting Bolt: 44 N·m (4.5 kgf·m, 33 ft·lb)**

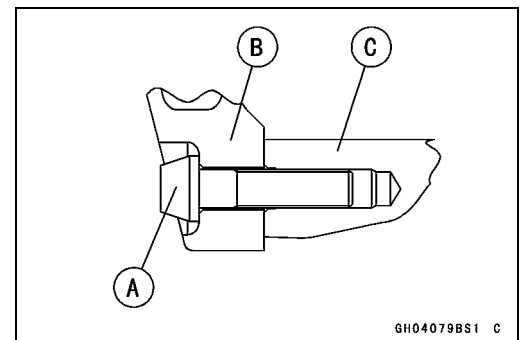

## 8-10 ENGINE REMOVAL/INSTALLATION

### Engine Removal/Installation

- Forth, tighten the adjuster collar [A] with the lower engine mounting bolt [B] counterclockwise until the collar touches [C] the frame [D].

**Torque - Lower Engine Mounting Bolt: 9.8 N·m (1.0 kgf·m, 87 in·lb)**

- Fifth, tighten the lower and middle engine mounting bolt nuts following sequence.

**Torque - Lower Engine Mounting Nut [E]: 44 N·m (4.5 kgf·m, 33 ft·lb)**

**Middle Engine Mounting Nut [F]: 44 N·m (4.5 kgf·m, 33 ft·lb)**

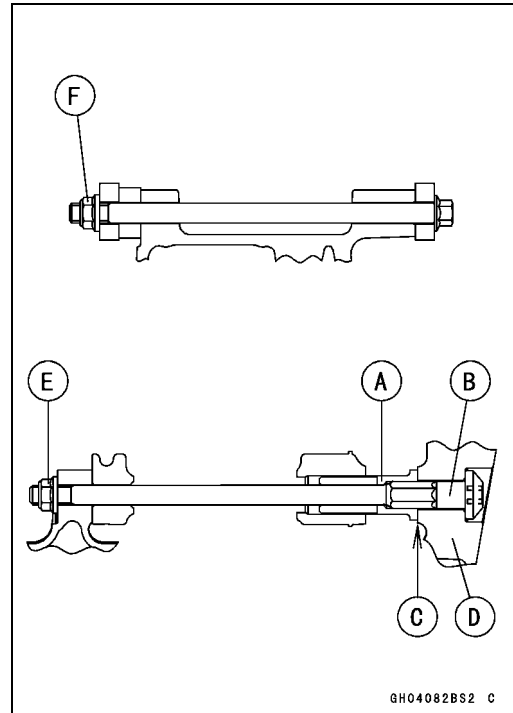

- Sixth, tighten the middle engine mounting bracket bolts [A].

**Torque - Middle Engine Mounting Bracket Bolts: 25 N·m (2.5 kgf·m, 18 ft·lb)**

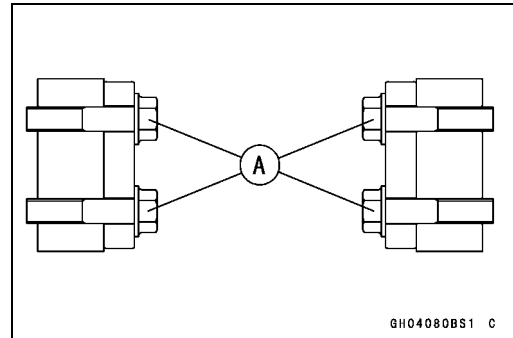

- Seventh, remove the right upper engine mounting bolt [A], and tighten the adjusting collar [B] counterclockwise until the clearance [C] between the engine [D] and collar come to 0 mm (0 in.).

- Eighth, holding the collar and tighten the adjusting collar locknut [E].

**Special Tool - Engine Mount Nut Wrench: 57001-1450**

**Torque - Adjusting Collar Locknut: 49 N·m (5.0 kgf·m, 36 ft·lb)**

- Lastly, tighten the right upper engine mounting bolt.

**Torque - Right Upper Engine Mounting Bolt: 44 N·m (4.5 kgf·m, 33 ft·lb)**

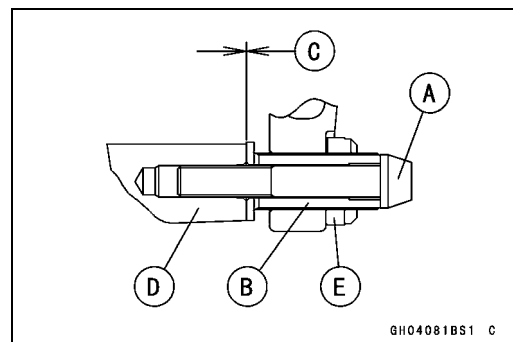

### Engine Removal/Installation

---

- Run the leads, cable and hoses correctly (see Cable, Wire, and Hose Routing section in the Appendix chapter).
- Install the removed parts (see appropriate chapters).
- Adjust:
  - Throttle Cables (see Throttle Control System Inspection in the Periodic Maintenance chapter)
  - Clutch Cable (see Clutch Operation Inspection in the Periodic Maintenance chapter)
  - Drive Chain (see Drive Chain Slack Inspection in the Periodic Maintenance chapter)
- Fill the engine with engine oil (see Engine Oil Change in the Periodic Maintenance chapter).
- Fill the engine with coolant and bleed the air from the cooling system (see Coolant Change in the Periodic Maintenance chapter).



# Crankshaft/Transmission

## Table of Contents

Exploded View .....	9-2	Starter Idle Gear Removal .....	9-31
Specifications .....	9-6	Starter Idle Gear Installation .....	9-31
Special Tools and Sealant .....	9-9	Starter Clutch Removal.....	9-33
Crankcase .....	9-10	Starter Clutch Installation .....	9-33
Crankcase Splitting.....	9-10	Starter Clutch Disassembly.....	9-33
Crankcase Assembly .....	9-11	Starter Clutch Assembly .....	9-34
Crankshaft and Connecting Rods.....	9-16	Starter Clutch Inspection.....	9-34
Crankshaft Removal .....	9-16	Transmission .....	9-36
Crankshaft Installation .....	9-16	Shift Pedal Removal .....	9-36
Connecting Rod Removal.....	9-18	Shift Pedal Installation .....	9-36
Connecting Rod Installation.....	9-18	External Shift Mechanism	
Crankshaft/Connecting Rod		Removal .....	9-36
Cleaning .....	9-22	External Shift Mechanism	
Connecting Rod Bend.....	9-22	Installation .....	9-37
Connecting Rod Twist.....	9-22	External Shift Mechanism	
Connecting Rod Big End Side		Inspection.....	9-37
Clearance.....	9-22	Transmission Assy Removal.....	9-38
Connecting Rod Big End Bearing		Transmission Assy Disassembly .	9-38
Insert/Crankpin Wear .....	9-23	Transmission Assy Assembly .....	9-39
Crankshaft Side Clearance .....	9-24	Transmission Assy Installation.....	9-40
Crankshaft Runout.....	9-25	Transmission Shaft Removal.....	9-41
Crankshaft Main Bearing		Transmission Shaft Installation ....	9-41
Insert/Journal Wear.....	9-25	Transmission Shaft Disassembly .	9-42
Pistons.....	9-27	Transmission Shaft Assembly.....	9-42
Piston Removal.....	9-27	Shift Drum and Fork Removal.....	9-45
Piston Installation.....	9-28	Shift Drum and Fork Installation...	9-45
Cylinder Wear (Upper		Shift Drum Disassembly.....	9-45
Crankcase).....	9-29	Shift Drum Assembly .....	9-45
Piston Wear .....	9-29	Shift Fork Bending .....	9-45
Piston Ring, Piston Ring Groove		Shift Fork/Gear Groove Wear .....	9-46
Wear.....	9-29	Shift Fork Guide Pin/Drum	
Piston Ring Groove Width.....	9-30	Groove Wear .....	9-46
Piston Ring Thickness .....	9-30	Gear Dog and Gear Dog Hole	
Piston Ring End Gap .....	9-30	Damage.....	9-46
Starter Idle Gear and Starter Clutch..	9-31		

# 9-2 CRANKSHAFT/TRANSMISSION

## Exploded View

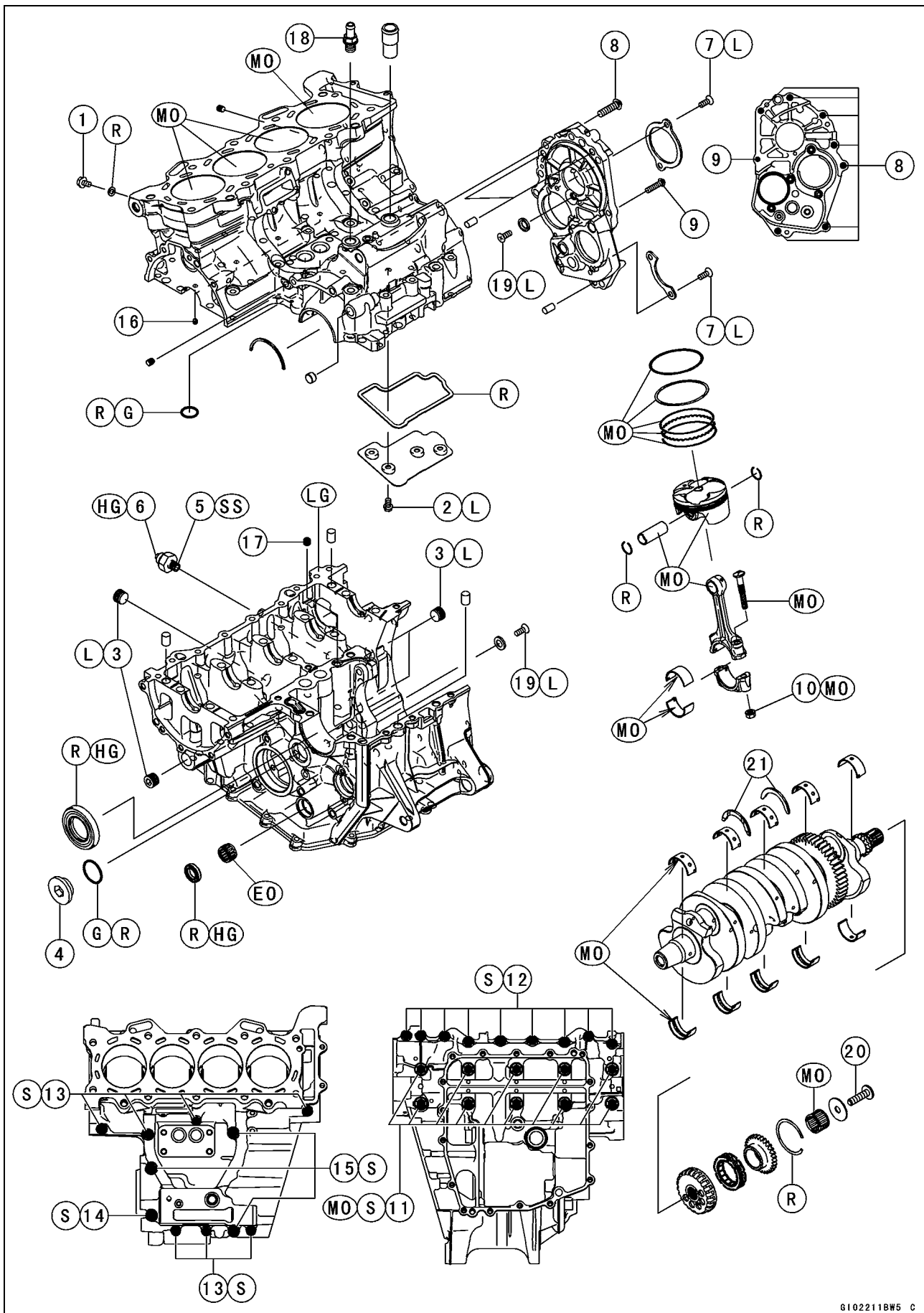

**Exploded View**

No.	Fastener	Torque			Remarks
		N·m	kgf·m	ft·lb	
1	Coolant Drain Plug (Cylinder)	9.8	1.0	87 in·lb	
2	Breather Plate Bolts	9.8	1.0	87 in·lb	L
3	Oil Passage Plugs (Taper)	20	2.0	15	L
4	Oil Passage Plug (Left Side)	17	1.7	12	
5	Oil Pressure Switch	15	1.5	11	SS
6	Oil Pressure Switch Terminal Bolt	–	–	–	Hand-tighten
7	Bearing Holder Screws	4.9	0.50	43 in·lb	L
8	Transmission Case Bolts (M8)	20	2.0	15	
9	Transmission Case Bolt (M6)	9.8	1.0	87 in·lb	
10	Connecting Rod Big End Nuts	see the text	←	←	MO
11	Crankcase Bolts (M8) (Lower) (First)	15	1.5	11	MO, S
	Crankcase Bolts (M8) (Lower) (Final)	31	3.2	23	MO, S
12	Crankcase Bolts (M6, L = 50 mm) (Lower)	12	1.2	106 in·lb	S
13	Crankcase Bolts (M6, L = 68 mm) (Upper)	12	1.2	106 in·lb	S
14	Crankcase Bolts (M8, L = 90 mm) (Upper)	27	2.8	20	S
15	Crankcase Bolt (M8, L = 75 mm) (Upper)	27	2.8	20	S
16	Piston Oil Nozzles	2.9	0.30	26 in·lb	
17	Oil Passage Nozzle	4.9	0.50	43 in·lb	
18	Breather Hose Fitting	15	1.5	11	L
19	Race Holder Screws	4.9	0.50	43 in·lb	L
20	Starter Clutch Bolt	49	5.0	36	

21. Install the thrust washers so that the grooves face the crankshaft and apply molybdenum disulfide grease to grooves side.

EO: Apply engine oil.

G: Apply grease.

HG: Apply high-temperature grease.

L: Apply a non-permanent locking agent.

LG: Apply liquid gasket.

MO: Apply molybdenum disulfide oil solution.

(mixture of the engine oil and molybdenum disulfide grease in a weight ratio 10:1)

R: Replacement Parts

S: Follow the specified tightening sequence.

SS: Apply silicone sealant.





## CRANKSHAFT/TRANSMISSION 9-5

### Exploded View

No.	Fastener	Torque			Remarks
		N·m	kgf·m	ft·lb	
1	Gear Positioning Lever Bolt	12	1.2	106 in·lb	
2	Gear Position Switch Screws	2.9	0.30	26 in·lb	L
3	Shift Drum Cam Holder Bolt	12	1.2	106 in·lb	L
4	Shift Lever Bolt	6.9	0.70	61 in·lb	
5	Shift Pedal Mounting Bolt	25	2.5	18	
6	Shift Shaft Return Spring Pin	28	2.9	21	L
7	Shift Tie-Rod Locknut	6.9	0.70	61 in·lb	Lh
8	Shift Tie-Rod Locknut	6.9	0.70	61 in·lb	
9	Starter Clutch Bolt Cap	–	–	–	Hand-tighten
10	Timing Inspection Cap	–	–	–	Hand-tighten
11	Starter Clutch Cover Bolts	9.8	1.0	87 in·lb	
12	Idle Gear Cover Bolts	9.8	1.0	87 in·lb	with Washer
13	Idle Gear Cover Bolts	9.8	1.0	87 in·lb	

EO: Apply engine oil.

L: Apply a non-permanent locking agent.

Lh: Left-hand Threads

MO: Apply molybdenum disulfide oil solution.

(mixture of the engine oil and molybdenum disulfide grease in a weight ratio 10:1)

R: Replacement Parts

## 9-6 CRANKSHAFT/TRANSMISSION

### Specifications

Item	Standard	Service Limit
<b>Crankcase, Crankshaft, Connecting Rods</b>		
Connecting Rod Bend	---	TIR 0.2/100 mm (0.008/3.94 in.)
Connecting Rod Twist	---	TIR 0.2/100 mm (0.008/3.94 in.)
Connecting Rod Big End Side Clearance	0.13 ~ 0.33 mm (0.0051 ~ 0.0130 in.)	0.6 mm (0.024 in.)
Connecting Rod Big End Bearing Insert/Crankpin Clearance	0.044 ~ 0.081 mm (0.0017 ~ 0.0032 in.)	0.12 mm (0.0047 in.)
Crankpin Diameter:	29.987 ~ 30.000 mm (1.1806 ~ 1.1811 in.)	29.97 mm (1.1799 in.)
Marking:		
None	29.984 ~ 29.992 mm (1.1805 ~ 1.1808 in.)	---
○	29.993 ~ 30.000 mm (1.1808 ~ 1.1811 in.)	---
Connecting Rod Big End Inside Diameter:	33.000 ~ 33.016 mm (1.2992 ~ 1.2998 in.)	---
Marking:		
None	33.000 ~ 33.008 mm (1.2992 ~ 1.2995 in.)	---
○	33.009 ~ 33.016 mm (1.2996 ~ 1.2998 in.)	---
Connecting Rod Big End Bearing Insert Thickness:		
Brown	1.475 ~ 1.480 mm (0.05807 ~ 0.05827 in.)	---
Black	1.480 ~ 1.485 mm (0.05827 ~ 0.05846 in.)	---
Blue	1.485 ~ 1.490 mm (0.05846 ~ 0.05866 in.)	---
Connecting Rod Bolt Stretch	(Usable Range) 0.28 ~ 0.38 mm (0.0110 ~ 0.0150 in.)	---
Crankshaft Side Clearance	0.05 ~ 0.25 mm (0.0020 ~ 0.0098 in.)	0.45 mm (0.0177 in.)
Crankshaft Runout	TIR 0.02 mm (0.0008 in.) or less	TIR 0.05 mm (0.0020 in.)
Crankshaft Main Bearing Insert/Journal Clearance	0.028 ~ 0.060 mm (0.0011 ~ 0.0024 in.)	0.09 mm (0.0035 in.)
Crankshaft Main Journal Diameter:	30.984 ~ 31.000 mm (1.2198 ~ 1.2205 in.)	30.96 mm (1.2189 in.)
Marking:		
None	30.984 ~ 30.992 mm (1.2198 ~ 1.2202 in.)	---
1	30.993 ~ 31.000 mm (1.2202 ~ 1.2205 in.)	---

## CRANKSHAFT/TRANSMISSION 9-7

### Specifications

Item	Standard	Service Limit
Crankcase Main Bearing Inside Diameter:	34.000 ~ 34.016 mm (1.3386 ~ 1.3392 in.)	- - -
Marking:		
○	34.000 ~ 34.008 mm (1.3386 ~ 1.3389 in.)	- - -
None	34.009 ~ 34.016 mm (1.3390 ~ 1.3392 in.)	- - -
Crankshaft Main Bearing Insert Thickness:		
Brown	1.491 ~ 1.495 mm (0.0587 ~ 0.0589 in.)	- - -
Black	1.495 ~ 1.499 mm (0.0589 ~ 0.0590 in.)	- - -
Blue	1.499 ~ 1.503 mm (0.0590 ~ 0.0592 in.)	- - -
<b>Cylinder, Piston</b>		
Cylinder (Upper Crankcase) Inside Diameter	67.000 ~ 67.012 mm (2.6378 ~ 2.6383 in.)	 67.09 mm (2.64 in.)
Piston Diameter	66.975 ~ 66.990 mm (2.6368 ~ 2.6374 in.)	66.83 mm (2.631 in.)
Piston/Cylinder Clearance	0.010 ~ 0.037 mm (0.0004 ~ 0.0015 in.)	- - -
Piston Ring/Groove Clearance:		
Top	0.05 ~ 0.09 mm (0.0020 ~ 0.0035 in.)	0.19 mm (0.0075 in.)
Second	0.03 ~ 0.07 mm (0.0012 ~ 0.0028 in.)	0.17 mm (0.0067 in.)
Piston Ring Groove Width:		
Top	0.84 ~ 0.86 mm (0.0331 ~ 0.0339 in.)	0.94 mm (0.037 in.)
Second	0.82 ~ 0.84 mm (0.0323 ~ 0.0331 in.)	0.92 mm (0.036 in.)
Piston Ring Thickness:		
Top	0.77 ~ 0.79 mm (0.0303 ~ 0.0311 in.)	0.70 mm (0.028 in.)
Second	0.77 ~ 0.79 mm (0.0303 ~ 0.0311 in.)	0.70 mm (0.028 in.)
Piston Ring End Gap:		
Top	0.12 ~ 0.22 mm (0.0047 ~ 0.0087 in.)	0.5 mm (0.020 in.)
Second	0.30 ~ 0.45 mm (0.0118 ~ 0.0177 in.)	0.8 mm (0.031 in.)
<b>Transmission</b>		
Shift Fork Ear Thickness	5.9 ~ 6.0 mm (0.232 ~ 0.236 in.)	5.8 mm (0.228 in.)
Gear Groove Width	6.05 ~ 6.15 mm (0.238 ~ 0.242 in.)	6.25 mm (0.246 in.)

## 9-8 CRANKSHAFT/TRANSMISSION

### Specifications

Item	Standard	Service Limit
Shift Fork Guide Pin Diameter	5.9 ~ 6.0 mm (0.232 ~ 0.236 in.)	5.8 mm (0.228 in.)
Shift Drum Groove Width	6.05 ~ 6.20 mm (0.238 ~ 0.244 in.)	6.3 mm (0.248 in.)

### Connecting Rod Big End Bearing Insert Selection

Con-rod Big End Inside Diameter Marking	Crankpin Diameter Marking	Bearing Insert	
		Size Color	Part Number
None	○	Brown	92139-0167
None	None	Black	92139-0166
○	○		
○	None	Blue	92139-0165

### Crankshaft Main Bearing Insert Selection (Engine No. ~ ZX600PE008560)

Crankcase Main Bearing Inside Diameter Marking	Crankshaft Main Journal Diameter Marking	Bearing Insert*		
		Size Color	Part Number	Journal Nos.
○	1	Brown	92139-0173	5
			92139-0191	1, 2, 3, 4
None	1	Black	92139-0172	5
○	None		92139-0190	1, 2, 3, 4
None	None	Blue	92139-0171	5
			92139-0189	1, 2, 3, 4

\*: The bearing inserts for Nos. 1, 2, 3 and 4 journals have an oil groove, respectively.

### Crankshaft Main Bearing Insert Selection (Engine No. ZX600PE008561 ~)

Crankcase Main Bearing Inside Diameter Marking	Crankshaft Main Journal Diameter Marking	Bearing Insert*		
		Size Color	Part Number	Journal Nos.
○	1	Brown	92139-0173	3, 5
			92139-0191	1, 2, 4
None	1	Black	92139-0172	3, 5
○	None		92139-0190	1, 2, 4
None	None	Blue	92139-0171	3, 5
			92139-0189	1, 2, 4

\*: The bearing inserts for Nos. 1, 2 and 4 journals have an oil groove, respectively.

Special Tools and Sealant

Outside Circlip Pliers:  
57001-144

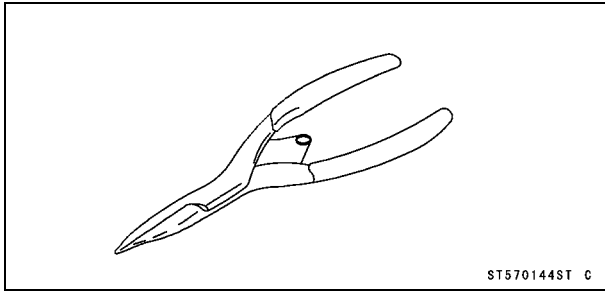

Grip:  
57001-1591

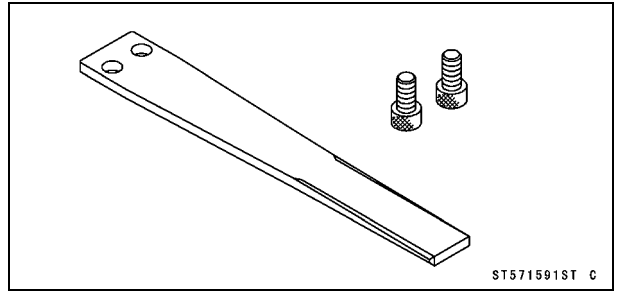

Piston Pin Puller Assembly:  
57001-910

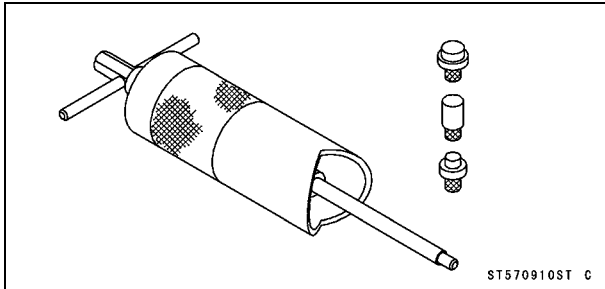

Rotor Holder:  
57001-1666

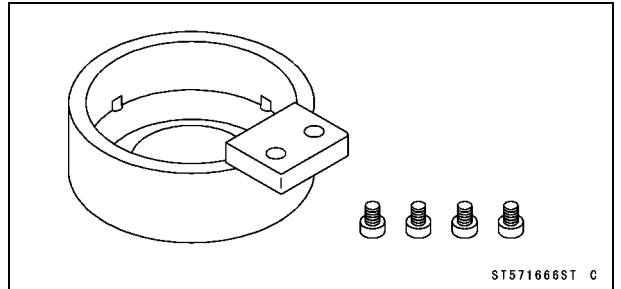

Piston Ring Compressor Grip:  
57001-1095

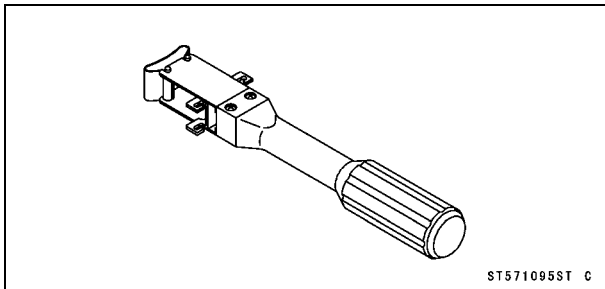

Stopper:  
57001-1679

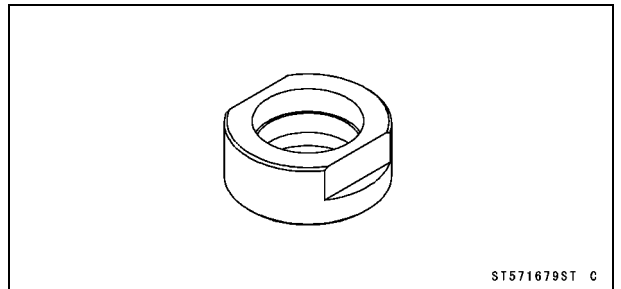

Piston Ring Compressor Belt,  $\phi 67 \sim \phi 79$ :  
57001-1097

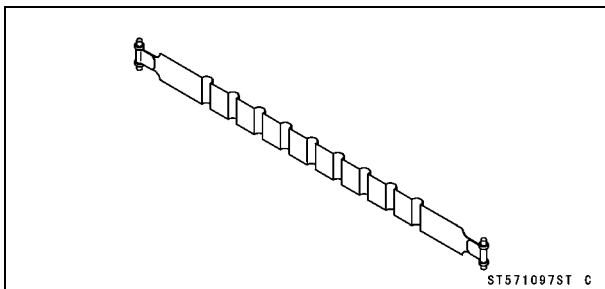

Kawasaki Bond (Silicone Sealant):  
92104-0004

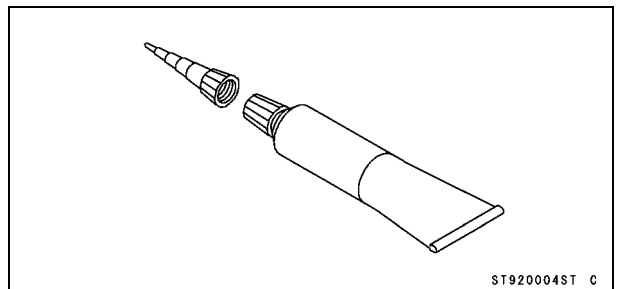

Bearing Driver Set:  
57001-1129

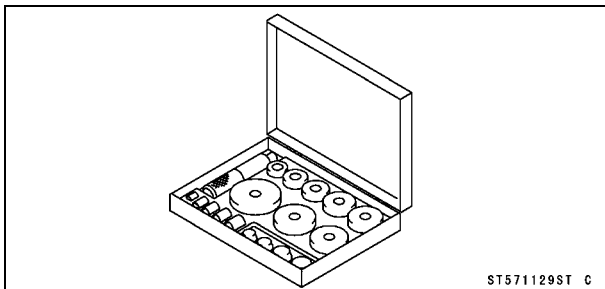

Kawasaki Bond:  
92104-1064

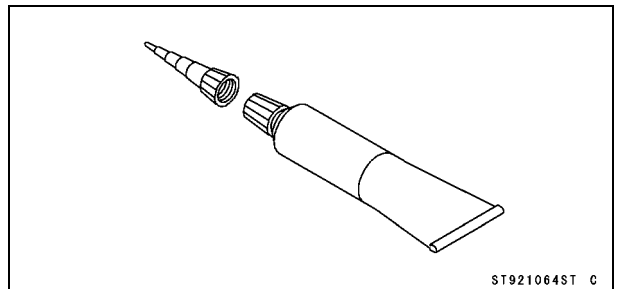

## 9-10 CRANKSHAFT/TRANSMISSION

### Crankcase

#### **Crankcase Splitting**

- Remove the engine (see Engine Removal in the Engine Removal/Installation chapter).
- Set the engine on a clean surface and hold the engine steady while parts are being removed.
- Remove:
  - Cylinder Head (see Cylinder Head Removal in the Engine Top End chapter)
  - Clutch (see Clutch Removal in the Clutch chapter)
  - Starter Motor (see Starter Motor Removal in the Electrical System chapter)
  - Starter Clutch (see Starter Clutch Removal)
  - Oil Pump (see Oil Pump Removal in the Engine Lubrication System chapter)
  - Alternator Rotor (see Alternator Rotor Removal in the Electrical System chapter)
  - Oil Cooler/Oil Filter Case (see Oil Cooler/Oil Filter Case Removal in the Engine Lubrication System chapter)
  - Oil Pan (see Oil Pan Removal in the Engine Lubrication System chapter)
  - Oil Screen (see Oil Pressure Relief Valve Removal in the Engine Lubrication System chapter)
  - External Shift Mechanism (see External Shift Mechanism Removal)
  - Transmission Assy (see Transmission Assy Removal)

- Remove the upper crankcase bolts.
  - First loosen the M6 bolts.
    - M6 Bolts [A]
    - M8 Bolt (L = 90 mm) [B]
    - M8 Bolts (L = 75 mm) [C]
  - Remove the bracket for oxygen sensor lead connector. (Equipped Models)

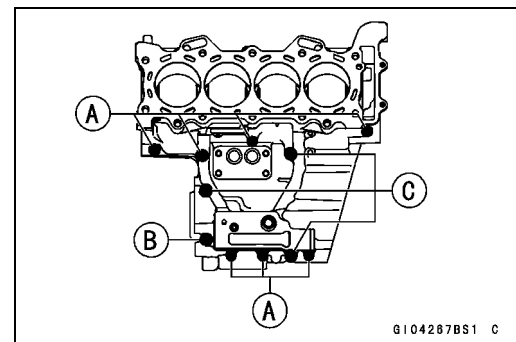

- Remove the lower crankcase bolts.
  - First loosen the M6 bolts.
    - M6 Bolts [A]
    - M8 Bolts [B]

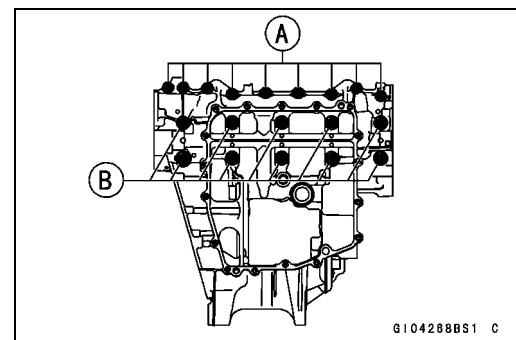

## Crankcase

- Loosen the M8 bolts [1 ~ 10] (sequence numbers).
- Tap lightly around the crankcase mating surface with a plastic mallet, and split the crankcase. Take care not to damage the crankcase.

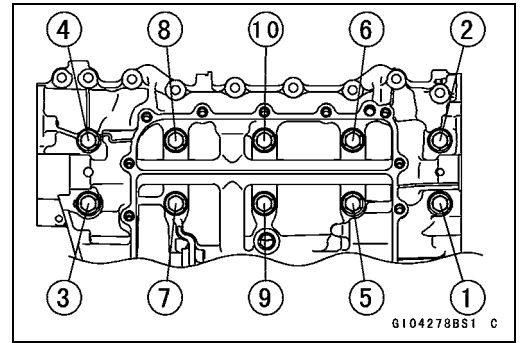

## Crankcase Assembly

### CAUTION

The upper and lower crankcase halves are machined at the factory in the assembled state, so the crankcase halves must be replaced as a set.

- With a high-flash point solvent, clean off the mating surfaces of the crankcase halves and wipe dry.
- Using compressed air, blow out the oil passages in the crankcase halves.
- When installing the breather plate to upper crankcase, replace the gasket [A] with a new one.

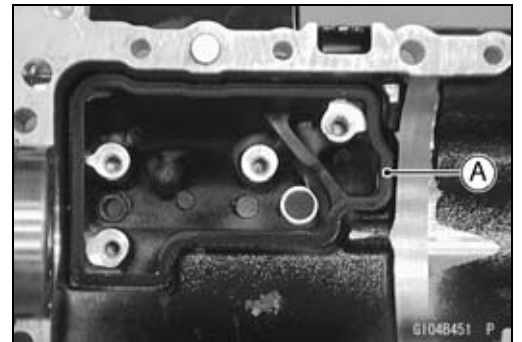

- Apply a non-permanent locking agent to the threads and tighten the bolts [A].

**Torque - Breather Plate Bolts: 9.8 N-m (1.0 kgf-m, 87 in-lb)**

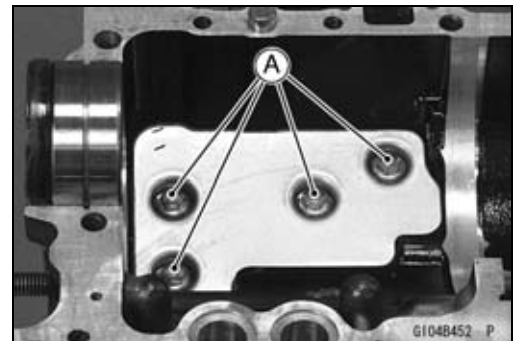

## 9-12 CRANKSHAFT/TRANSMISSION

### Crankcase

- Press and insert the fitting [A] in the upper crankcase [B] until it is bottomed.

**Special Tool - Bearing Driver Set: 57001-1129**

- Apply a non-permanent locking agent to threads of the breather hose fitting [C] and tighten it.

**Torque - Breather Hose Fitting: 15 N·m (1.5 kgf·m, 11 ft·lb)**

- Press and insert the plug [D] in the upper crankcase so that the plug surface [E] is flush with the end of the hole.

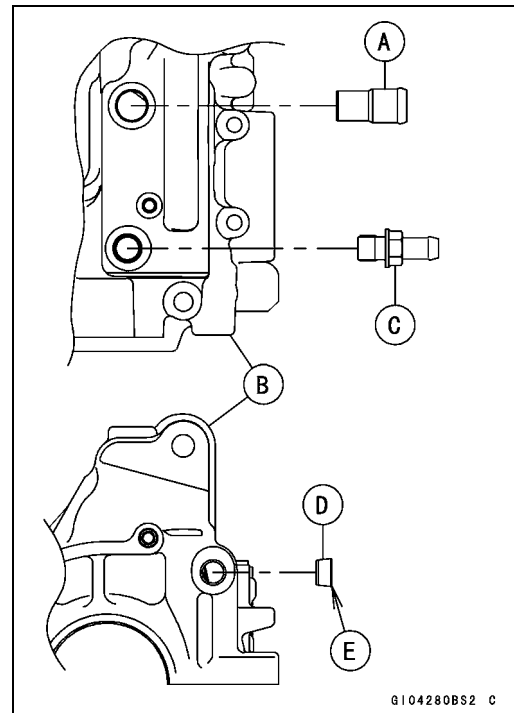

- Install the oil plugs [A] so that its surface is flush with the end of the hole.

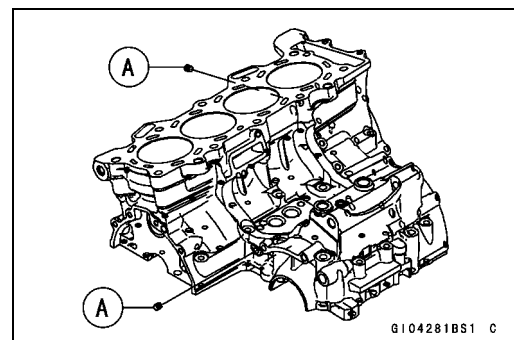

- Install the oil nozzles [A] in the upper crankcase, and tighten them.

**Torque - Oil Nozzles: 2.9 N·m (0.30 kgf·m, 26 in·lb)**

- Install:
  - Position Ring [B]
  - Ball Bearing [C]

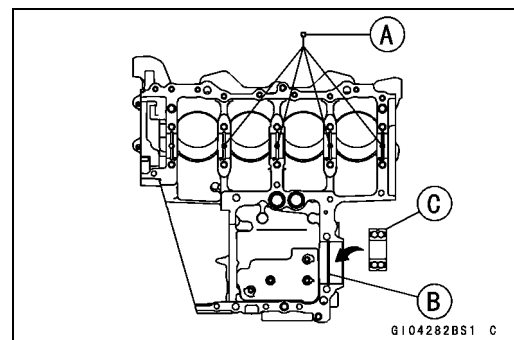

- Press and insert the race [A] in the lower crankcase [B] so that the big stepped side faces to inside of the crankcase until it is bottomed.

- Install the race holder [C] as shown in the figure.
- Apply a non-permanent locking agent to the race holder screw [D].
- Tighten:

**Torque - Race Holder Screw: 4.9 N·m (0.50 kgf·m, 43 in·lb)**

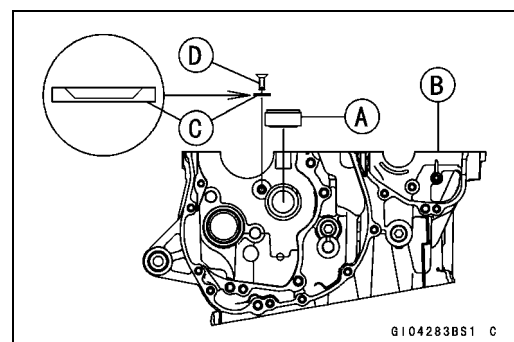



## Crankcase

- Press and insert the new needle bearing [A] for the shift shaft so that its marked side faces outside [B] and its surface [C] is flush with the end of the hole.
- Install the new oil seal [D] so that its surface [E] is flush with the end of the hole.
- Apply grease to the lips of the oil seal.

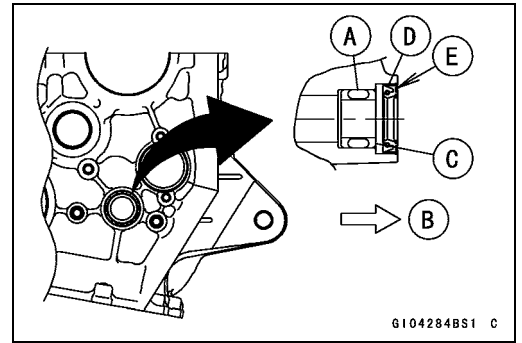

- Install the oil passage nozzle [A] in the lower crankcase, and tighten it.

**Torque - Oil Passage Nozzle: 4.9 N·m (0.50 kgf·m, 43 in·lb)**

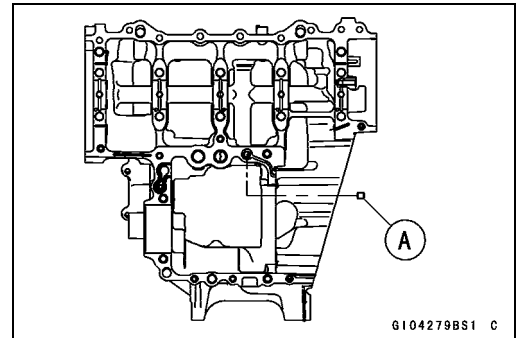

- Install:
  - Crankshaft and Connecting Rods
  - Camshaft Chain [A]
  - Dowel Pins [B]
  - O-rings [C]
- Before fitting the lower case on the upper case, check the following.
  - Be sure to hang the camshaft chain on the crankshaft.

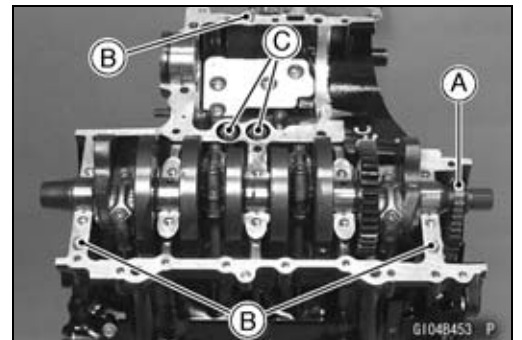

## 9-14 CRANKSHAFT/TRANSMISSION

### Crankcase

- Apply liquid gasket [A] to the mating surface of the lower crankcase half.

Sealant - Kawasaki Bond: 92104-1064

- Pile up the liquid gasket to groove [B].

#### CAUTION

Do not apply liquid gasket to the inside of the grooves [C] around the crankshaft main bearing inserts and oil passage.

#### NOTE

- Make the application finish within 20 minutes when the liquid gasket to the mating surface of the lower crankcase half is applied.

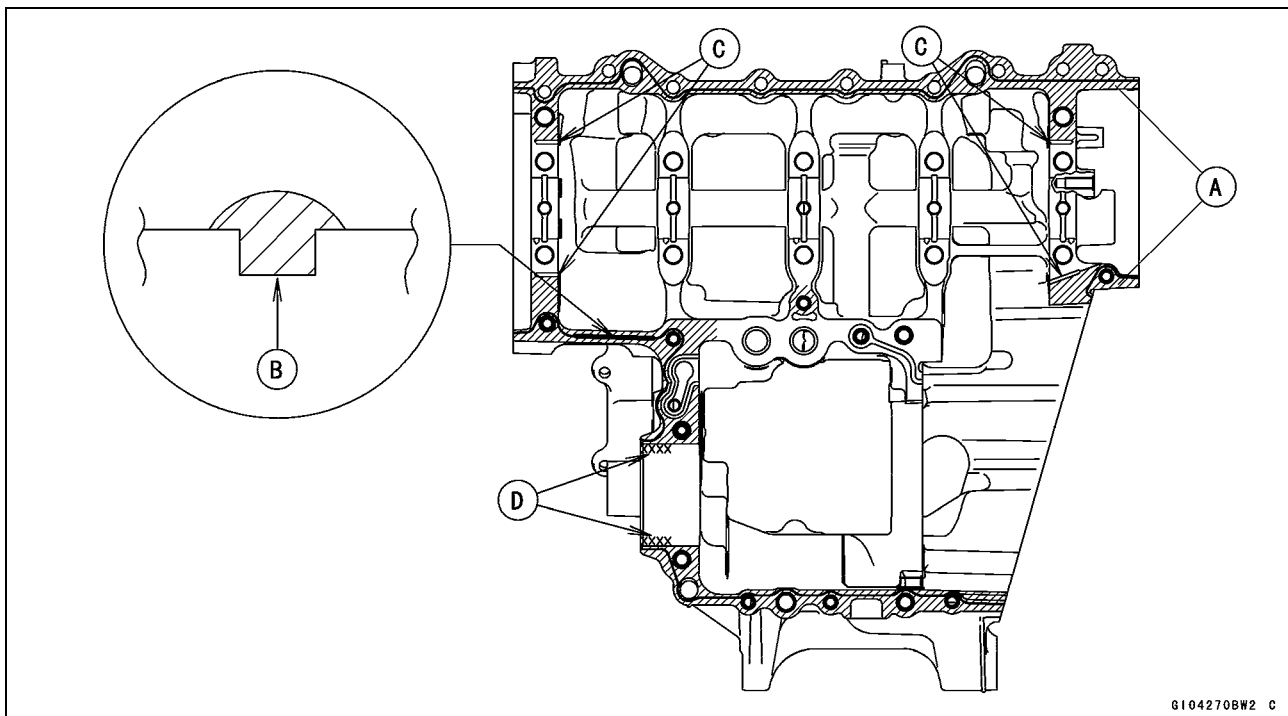

- Replace the washers [A] of the M8 bolts [B] with new ones.
- Apply molybdenum disulfide oil solution to both sides [C] of the washers and threads [D] of M8 bolts.

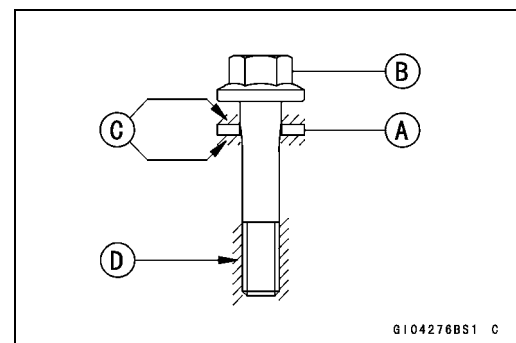

**Crankcase**

- Following the sequence numbers on the lower crankcase half, tighten M8 bolts [1 ~ 10] with washers.

**Torque - Crankcase Bolts (M8) [A]:**

**First: 15 N·m (1.5 kgf·m, 11 ft·lb)**

**Final: 31 N·m (3.2 kgf·m, 23 ft·lb)**

- Install the bracket [B] for oxygen sensor lead connector as shown in the figure (equipped models).
- Tighten the M6 bolts [C].

**Torque - Crankcase Bolts (M6): 12 N·m (1.2 kgf·m, 106 in·lb)**

- Replace the washers [A] of the M8 bolts [B] [C] with new ones.
- Tighten the upper crankcase bolts.

**Torque - Crankcase Bolts (M8, L = 90 mm) [B]: 27 N·m (2.8 kgf·m, 20 ft·lb)**

**Crankcase Bolts (M8, L = 75 mm) [C]: 27 N·m (2.8 kgf·m, 20 ft·lb)**

**Crankcase Bolts (M6) [D]: 12 N·m (1.2 kgf·m, 106 in·lb)**

- After tightening all crankcase bolts, check the following item.

○Crankshaft turns freely.

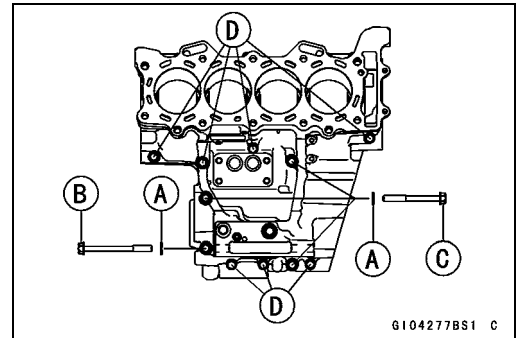
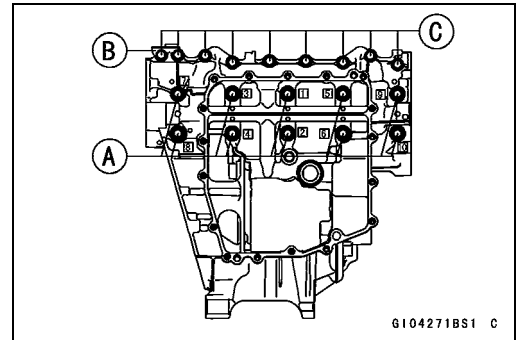

## 9-16 CRANKSHAFT/TRANSMISSION

### Crankshaft and Connecting Rods

#### **Crankshaft Removal**

- Split the crankcase (see crankcase splitting).
- Remove the connecting rod nuts.
- Remove the crankshaft.

#### **Crankshaft Installation**

##### **NOTE**

○ If the crankshaft is replaced with a new one, refer to the *Connecting Rod Big End Bearing/Crankshaft Main Bearing Insert Selection in the Specifications*.

##### **CAUTION**

**If the crankshaft, bearing inserts, or crankcase halves are replaced with new ones, select the bearing inserts and check clearance with a plastigage (press gauge) before assembling engine to be sure the correct bearing inserts are installed.**

- Apply molybdenum disulfide oil solution to the crankshaft main bearing inserts.
- Install the crankshaft with the camshaft chain [A] hanging on it.
- Install the connecting rod big end caps [B] (see Connecting Rod Installation).

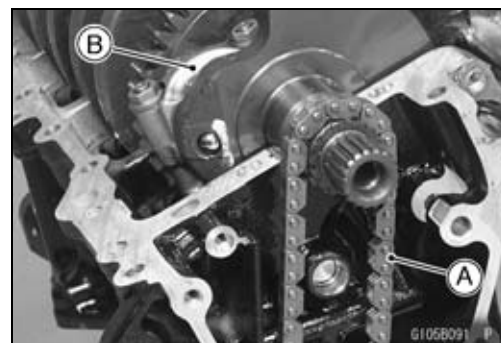

**Crankshaft and Connecting Rods**

- Apply molybdenum disulfide grease [A] to the outside surfaces of both thrust washers [B].
- Slide [C] one thrust washer into the upper crankcase half.
- Move the crankshaft to the left or right and then slide the other washer into the upper crankcase half.

**NOTE**

○ Slide the thrust washers so that the oil grooves [D] face outward. Make sure that the blue-painted edges [E] are positioned as shown in figure.  
Front [F]

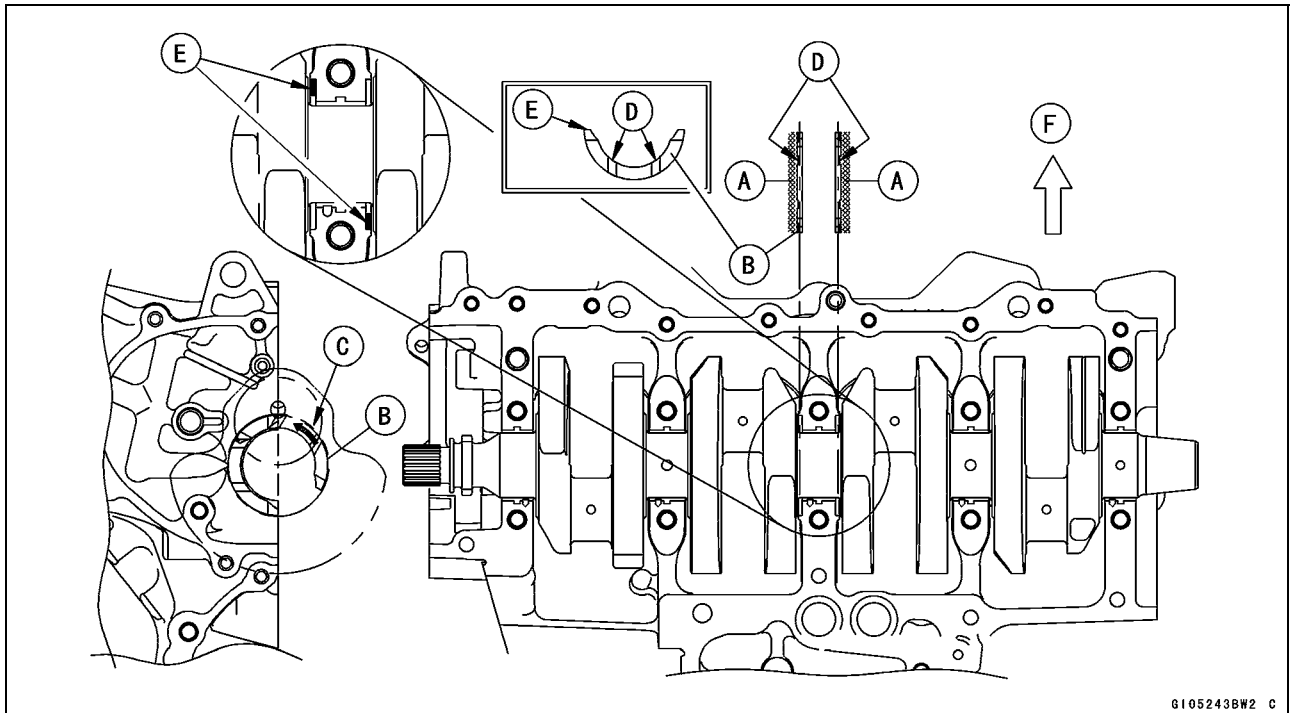

G105243BW2 C

**NOTE**

○ There are two kinds of crankcase by the engine number.

Engine No.	Crankcase Part No.	Washer Part No.	Washer Thickness
~ ZX600PE008560	14001-0112	92200-0383	2.5 mm (0.098 in.)
ZX600PE008561 ~	14001-0113	92200-0385	3.25 mm (0.128 in.)

## 9-18 CRANKSHAFT/TRANSMISSION

### Crankshaft and Connecting Rods

#### Connecting Rod Removal

- Split the crankcase (see Crankcase Splitting in this chapter).
- Remove the connecting rod nuts [A] and big end caps [B].

#### NOTE

○ Mark and record the locations of the connecting rods and their big end caps so that they can be reassembled in their original positions.

- Remove:
  - Camshaft Chain [C]
  - Crankshaft [D]
  - Pistons [E] (see Piston Removal)

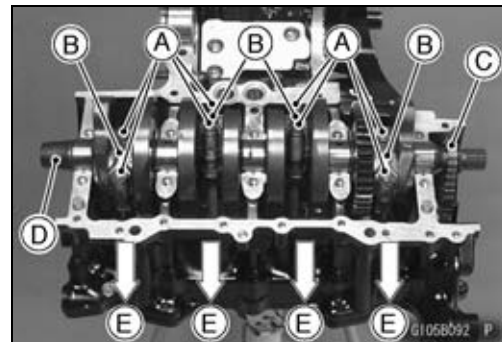

#### CAUTION

Discard the connecting rod bolts. To prevent damage to the crankpin surfaces, do not allow the connecting rod bolts to bump against the crankpins.

#### Connecting Rod Installation

#### CAUTION

To minimize vibration, the connecting rods should have the same weight mark.

- Big End Cap [A]
- Connecting Rod [B]
- Weight Mark, Alphabet [C]
- Diameter Mark [D]: "O" mark or no mark

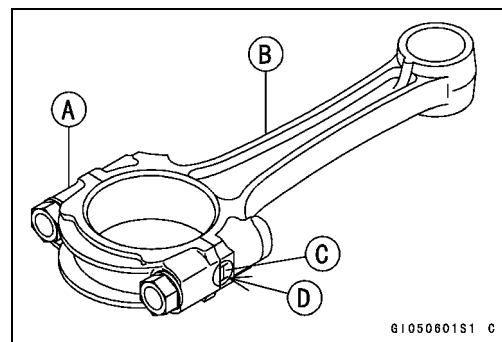

#### CAUTION

If the connecting rods, big end bearing inserts, or crankshaft are replaced with new ones, select the bearing insert and check clearance with a plastigage (press gauge) before assembling engine to be sure the correct bearing inserts are installed.

- Apply molybdenum disulfide oil solution to the inner surface of the upper and lower bearing inserts [A].
- Apply molybdenum disulfide oil solution to the threads [B] and seating surface [C] of the connecting rod nuts.
- Install the inserts so that their nails [D] are on the same side and fit them into the recess of the connecting rod and cap.

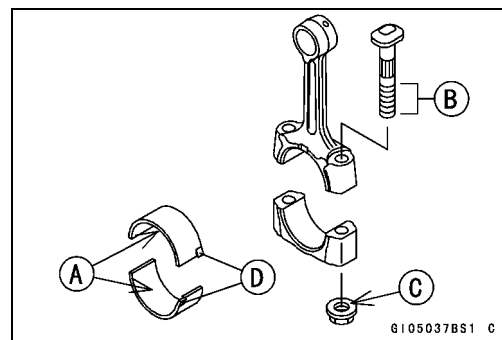

#### CAUTION

Wrong application of oil and grease could cause bearing damage.

**Crankshaft and Connecting Rods**

- When installing the inserts [A], be careful not to damage the insert surface with the edge of the connecting rod [B] or the cap [C]. One way to install inserts is as follows.
  - Installation [D] to Cap
  - Installation [E] to Connecting Rod
  - Push [F]
  - Spare Dowel Pin [G]
  - Connecting Rod Bolts [H]
- Remove debris and clean the surface of inserts.

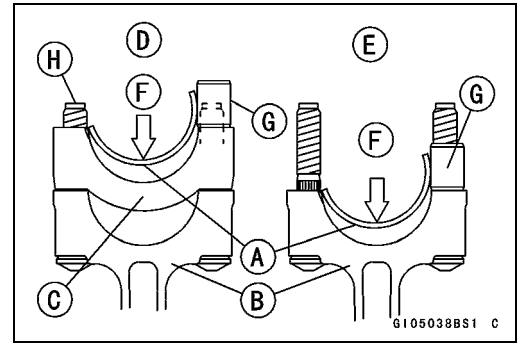

- Install the pistons (see Piston Installation).
- Install each connecting rod on its original position.
- Install the crankshaft (see Crankshaft Installation).
- Install the cap on the connecting rod, aligning the weight and diameter marks.
- The connecting rod big end is bolted using the “plastic region fastening method”.
- This method precisely achieves the needed clamping force without exceeding it unnecessarily, allowing the use of thinner, lighter bolts further decreasing connecting rod weight.
- There are two types of the plastic region fastening. One is a bolt length measurement method and other is a rotation angle method. Observe one of the following two, but the bolt length measurement method is preferable because this is a more reliable way to tighten the big end nuts.

<b>CAUTION</b>
<b>The connecting rod bolts are designed to stretch when tightened. Never reuse the connecting rod bolts. See the table below for correct bolt and nut usage.</b>

<b>CAUTION</b>
<b>Be careful not to overtighten the nuts. The bolts must be positioned on the seating surface correctly to prevent the bolt heads from hitting the crankcase.</b>

## 9-20 CRANKSHAFT/TRANSMISSION

### Crankshaft and Connecting Rods

#### (1) Bolt Length Measurement Method

- Be sure to clean the bolts, nuts, and connecting rods thoroughly with a high-flash point solvent, because the new connecting rods, bolts, and nuts are treated with an anti-rust solution.

#### **⚠ WARNING**

Clean the bolts, nuts, and connecting rods in a well-ventilated area, and take care that there is no spark or flame anywhere near the working area. This includes any appliance with a pilot light. Because of the danger of highly flammable liquids, do not use gasoline or low-flash point solvents to clean them.

#### **CAUTION**

Immediately dry the bolts and nuts with compressed air after cleaning. Clean and dry the bolts and nuts completely.

- Install new bolts in reused connecting rods.
- Dent both bolt head and bolt tip with a punch as shown.
- Before tightening, use a point micrometer to measure the length of new connecting rod bolts and record the values to find the bolt stretch.
  - Connecting Rod [A]
  - Dent here with a punch [B].
  - Nuts [C]
  - Fit micrometer pins into dents [D].
- Apply a small amount of molybdenum disulfide oil solution to the following.
  - Threads of Nuts and Bolts
  - Seating Surfaces of Nuts and Connecting rods
- Tighten the big end nuts until the bolt elongation reaches the length specified in the table.
- Check the length of the connecting rod bolts.
- ★ If the stretch is more than the usable range, the bolt has stretched too much. An overelongated bolt may break in use.

$$\text{Bolt Length after tightening} - \text{Bolt Length before tightening} = \text{Bolt Stretch}$$

**Usable Range of Connecting Rod Bolt Stretch**  
**0.28 ~ 0.38 mm (0.0110 ~ 0.0150 in.)**

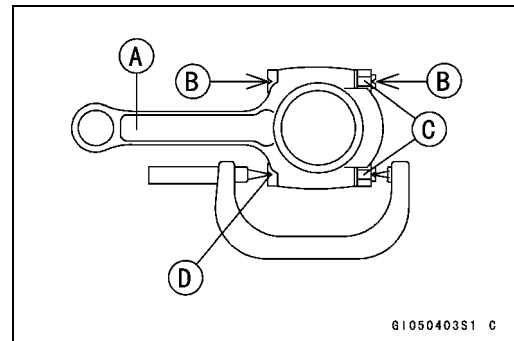



**Crankshaft and Connecting Rods**

(2) Rotation Angle Method

- ★ If you don't have a point micrometer, you may tighten the nuts using the "Rotation Angle Method".
- Be sure to clean the bolts, nuts and connecting rods thoroughly with a high-flash point solvent, because the new connecting rods, bolts and nuts are treated with an anti-rust solution.

**⚠ WARNING**

**Clean the bolts, nuts and connecting rods in a well-ventilated area, and take care that there is no spark or flame anywhere near the working area. This includes any appliance with a pilot light. Because of the danger of highly flammable liquids, do not use gasoline or low-flash point solvents to clean them.**

**CAUTION**

**Immediately dry the bolts and nuts with compressed air after cleaning. Clean and dry the bolts and nuts completely.**

- Install new bolts in reused connecting rods.
- Apply a small amount of molybdenum disulfide oil solution to the following.
  - Threads [A] of Nuts and Bolts
  - Seating Surfaces [B] of Nuts and Connecting Rods

- First, tighten the nuts to the specified torque (see table below).
- Next, tighten the nuts **180°**.
- Mark [A] the connecting rod big end caps and nuts so that nuts can be turned 180° [B] properly.

Connecting Rod Assy	Bolt, Nut	Torque + Angle N·m (kgf·m, in·lb)
New	Use the bolts attached to new con-rod.	11.8 (1.2, 104) + 180°
	Another new bolts and nuts	11.8 (1.2, 104) + 180°
Used	Replace the bolts and nuts with new ones	11.8 (1.2, 104) + 180°

**CAUTION**

**Be careful not to overtighten the nuts.**

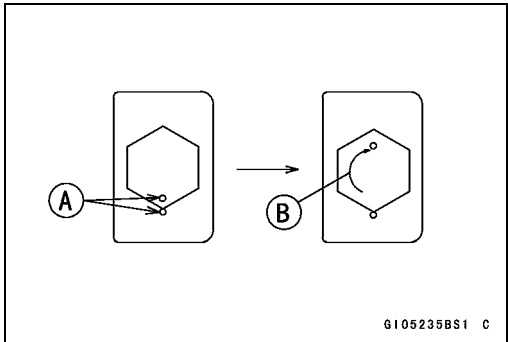
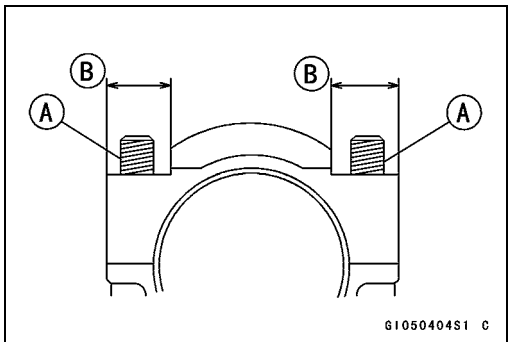

## 9-22 CRANKSHAFT/TRANSMISSION

### Crankshaft and Connecting Rods

#### **Crankshaft/Connecting Rod Cleaning**

- After removing the connecting rods from the crankshaft, clean them with a high-flash point solvent.
- Blow the crankshaft oil passages with compressed air to remove any foreign particles or residue that may have accumulated in the passages.

#### **Connecting Rod Bend**

- Remove the connecting rod big end bearing inserts, and reinstall the connecting rod big end cap.
- Select an arbor [A] of the same diameter as the connecting rod big end, and insert the arbor through the connecting rod big end.
- Select an arbor of the same diameter as the piston pin and at least 100 mm (3.94 in.) long, and insert the arbor [B] through the connecting rod small end.
- On a surface plate, set the big-end arbor on V block [C].
- With the connecting rod held vertically, use a height gauge to measure the difference in the height of the arbor above the surface plate over a 100 mm (3.94 in.) length to determine the amount of connecting rod bend.
- ★ If connecting rod bend exceeds the service limit, the connecting rod must be replaced.

#### **Connecting Rod Bend**

**Service Limit: TIR 0.2/100 mm (0.008/3.94 in.)**

#### **Connecting Rod Twist**

- With the big-end arbor [A] still on V block [C], hold the connecting rod horizontally and measure the amount that the arbor [B] varies from being paralleled with the surface plate over a 100 mm (3.94 in.) length of the arbor to determine the amount of connecting rod twist.
- ★ If connecting rod twist exceeds the service limit, the connecting rod must be replaced.

#### **Connecting Rod Twist**

**Service Limit: TIR 0.2/100 mm (0.008/3.94 in.)**

#### **Connecting Rod Big End Side Clearance**

- Measure connecting rod big end side clearance.
- Insert a thickness gauge [A] between the big end and either crank web to determine clearance.

#### **Connecting Rod Big End Side Clearance**

**Standard: 0.13 ~ 0.33 mm (0.0051 ~ 0.0130 in.)**

**Service Limit: 0.6 mm (0.024 in.)**

- ★ If the clearance exceeds the service limit, replace the connecting rod with new one and then check clearance again. If clearance is too large after connecting rod replacement, the crankshaft also must be replaced.

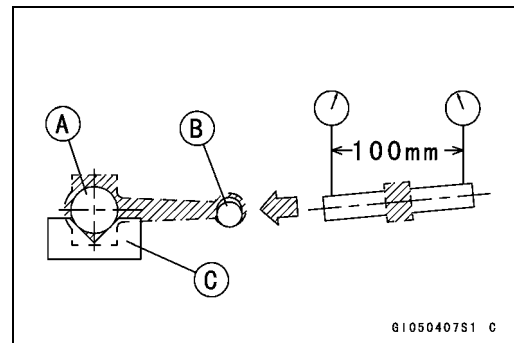
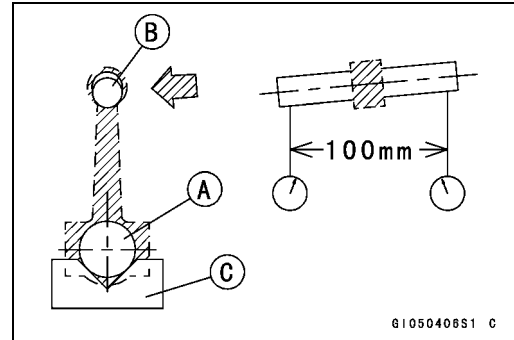

**Crankshaft and Connecting Rods**

**Connecting Rod Big End Bearing Insert/Crankpin Wear**

- Measure the bearing insert/crankpin [B] clearance with plastigage [A].
- Tighten the big end nuts to the specified torque (see Connecting Rod Installation).

**NOTE**

○ Do not move the connecting rod and crankshaft during clearance measurement.

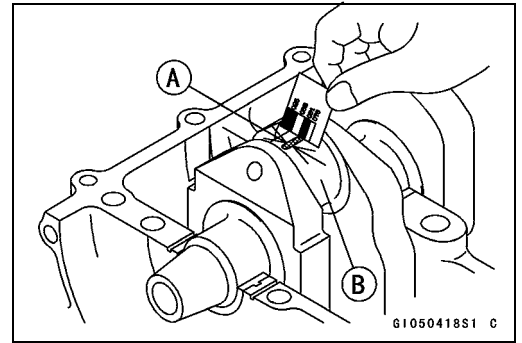

**CAUTION**

After measurement, replace the connecting rod bolts.

**Connecting Rod Big End Bearing Insert/Crankpin Clearance**

**Standard:** 0.044 ~ 0.081 mm (0.0017 ~ 0.0032 in.)

**Service Limit:** 0.12 mm (0.0047 in.)

- ★ If the clearance is within the standard, no bearing replacement is required.
- ★ If the clearance is between 0.082 mm (0.0032 in.) and the service limit (0.12 mm, 0.0047 in.), replace the bearing inserts [A] with inserts painted blue [B]. Check insert/crankpin clearance with the plastigage. The clearance may exceed the standard slightly, but it must not be less than the minimum in order to avoid bearing seizure.
- ★ If the clearance exceeds the service limit, measure the diameter [C] of the crankpins.

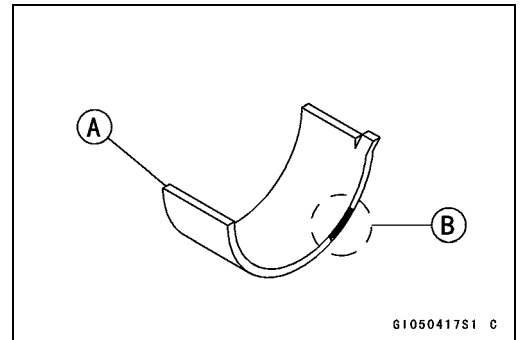

**Crankpin Diameter**

**Standard:** 29.987 ~ 30.000 mm (1.1806 ~ 1.1811 in.)

**Service Limit:** 29.97 mm (1.1799 in.)

- ★ If any crankpin has worn past the service limit, replace the crankshaft with a new one.
- ★ If the measured crankpin diameters are not less than the service limit, but do not coincide with the original diameter markings [D] on the crankshaft, make new marks on it.

**Crankpin Diameter Marks**

**None:** 29.984 ~ 29.992 mm (1.1805 ~ 1.1808 in.)

○: 29.993 ~ 30.000 mm (1.1808 ~ 1.1811 in.)

△: Crankpin Diameter Marks, “○” mark or no mark.

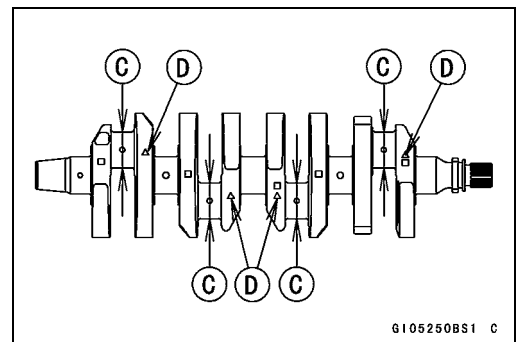

- Measure the connecting rod big end inside diameter, and mark each connecting rod big end in accordance with the inside diameter.
- Tighten the connecting rod big end nuts to the specified torque (see Connecting Rod Installation).

**NOTE**

○ The mark already on the big end should almost coincide with the measurement.

## 9-24 CRANKSHAFT/TRANSMISSION

### Crankshaft and Connecting Rods

#### Connecting Rod Big End Inside Diameter Marks

None: 33.000 ~ 33.008 mm (1.2992 ~ 1.2995 in.)

○: 33.009 ~ 33.016 mm (1.2996 ~ 1.2998 in.)

Big End Cap [A]

Connecting Rod [B]

Weight Mark, Alphabet [C]

Diameter Mark (Around Weight Mark) [D]: "○" mark or no mark

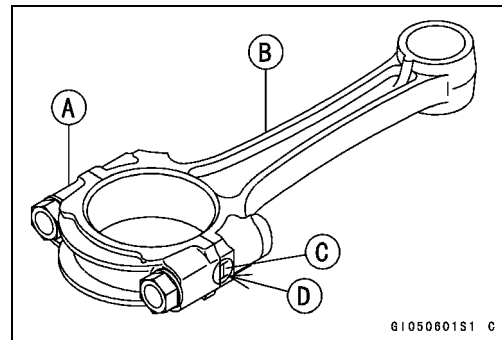

- Select the proper bearing insert [A] in accordance with the combination of the connecting rod and crankshaft coding.

Size Color [B]

Con-rod Big End Inside Diameter Marking	Crankpin Diameter Marking	Bearing Insert	
		Size Color	Part Number
None	○	Brown	92139-0167
None	None	Black	92139-0166
○	○		
○	None	Blue	92139-0165

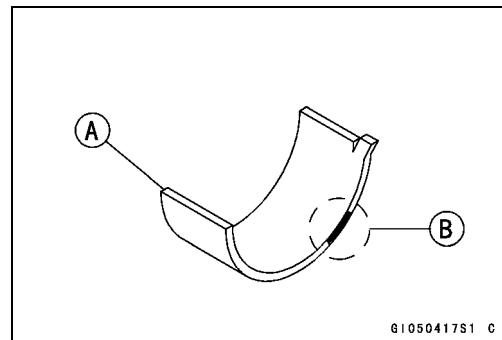

- Install the new inserts in the connecting rod and check insert/crankpin clearance with the plastigage.

- ★ If the insert/crankpin clearance is less than the service limit, replace the connecting rod bolts and nuts with new ones and measure the clearance again.

#### Crankshaft Side Clearance

- Insert a thickness gauge [A] between the thrust washer on the crankcase and the crank web at the #3 main journal [B] to determine clearance.

- ★ If the clearance exceeds the service limit, replace the thrust washers as a set and check the width of the crankshaft #3 main journal.

#### Crankshaft Side Clearance

Standard: 0.05 ~ 0.25 mm (0.0020 ~ 0.0098 in.)

Service Limit: 0.45 mm (0.0177 in.)

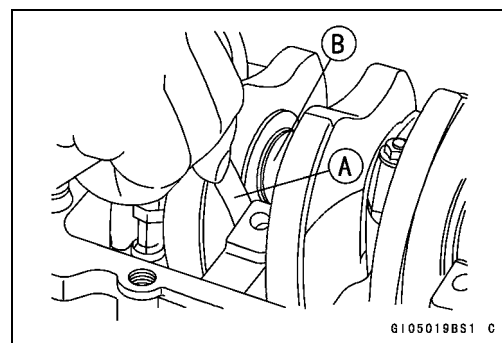

- Measure the width [A] of the crankshaft #3 main journal [B].

- ★ If the measurement exceeds the standard, replace the crankshaft.

#### Crankshaft #3 Main Journal Width

Standard: 21.09 ~ 21.14 mm (0.8303 ~ 0.8323 in.)

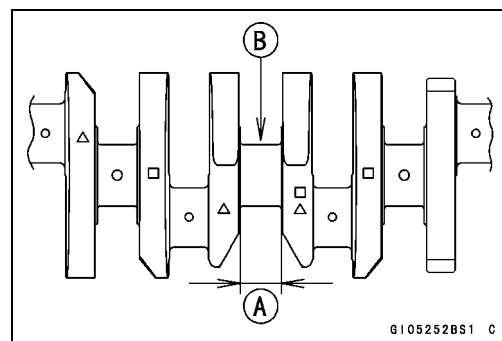

**Crankshaft and Connecting Rods**

**Crankshaft Runout**

- Measure the crankshaft runout.
- ★ If the measurement exceeds the service limit, replace the crankshaft.

**Crankshaft Runout**

**Standard:** TIR 0.02 mm (0.0008 in.) or less  
**Service Limit:** TIR 0.05 mm (0.0020 in.)

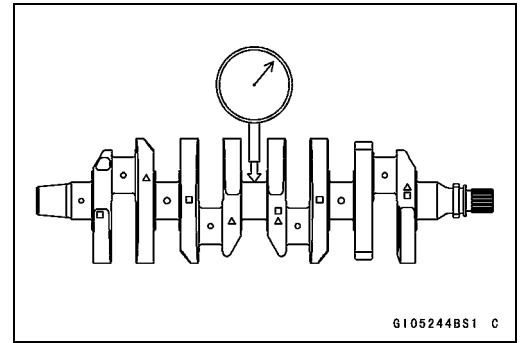

**Crankshaft Main Bearing Insert/Journal Wear**

- Using a plastigage (press gauge) [A], measure the bearing insert/journal [B] clearance.

**NOTE**

- Tighten the crankcase bolts to the specified torque (see Crankcase Assembly in this chapter).
- Do not turn the crankshaft during clearance measurement.
- Journal clearance less than 0.025 mm (0.00098 in.) can not be measured by plastigage, however, using genuine parts maintains the minimum standard clearance.

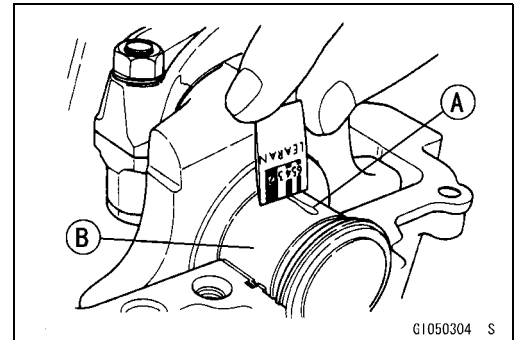

**Crankshaft Main Bearing Insert/Journal Clearance**

**Standard:** 0.028 ~ 0.060 mm (0.0011 ~ 0.0024 in.)  
**Service Limit:** 0.09 mm (0.0035 in.)

- ★ If the clearance is within the standard, no bearing replacement is required.
- ★ If the clearance is between 0.061 mm (0.0024 in.) and the service limit (0.09 mm, 0.0035 in.), replace the bearing inserts [A] with inserts painted blue [B]. Check insert/journal clearance with the plastigage. The clearance may exceed the standard slightly, but it must not be less than the minimum in order to avoid bearing seizure.
- ★ If the clearance exceeds the service limit, measure the diameter [C] of the crankshaft main journal.

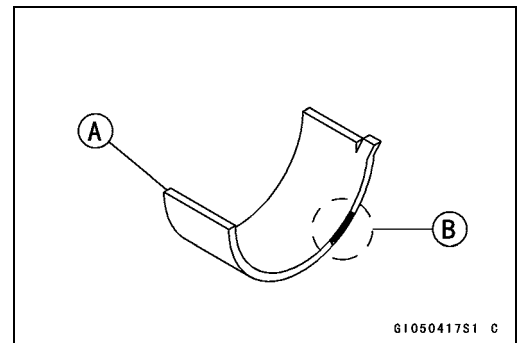

**Crankshaft Main Journal Diameter**

**Standard:** 30.984 ~ 31.000 mm (1.2198 ~ 1.2205 in.)  
**Service Limit:** 30.96 mm (1.2189 in.)

- ★ If any journal has worn past the service limit, replace the crankshaft with a new one.
- ★ If the measured journal diameters are not less than the service limit, but do not coincide with the original diameter markings [D] on the crankshaft, make new marks on it.

**Crankshaft Main Journal Diameter Marks**

**None:** 30.984 ~ 30.992 mm (1.2198 ~ 1.2202 in.)  
**1:** 30.993 ~ 31.000 mm (1.2202 ~ 1.2205 in.)

□: Crankshaft Main Journal Diameter Marks, "1" mark or no mark.

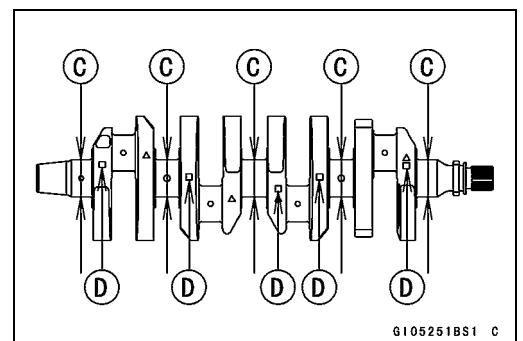

## 9-26 CRANKSHAFT/TRANSMISSION

### Crankshaft and Connecting Rods

- Measure the main bearing inside diameter, and mark the upper crankcase half in accordance with the inside diameter.

[A]: Crankcase Main Bearing Inside Diameter Marks, "○" mark or no mark.

- Tighten the crankcase bolts to the specified torque (see Crankcase Assembly in this chapter).

#### NOTE

○ The mark already on the upper crankcase half should almost coincide with the measurement.

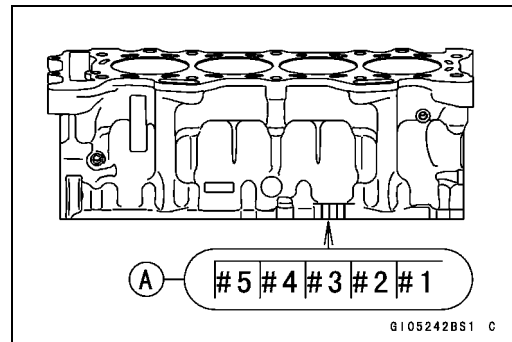

#### Crankcase Main Bearing Inside Diameter Marks

○: 34.000 ~ 34.008 mm (1.3386 ~ 1.3389 in.)

None: 34.009 ~ 34.016 mm (1.3390 ~ 1.3392 in.)

- Select the proper bearing insert [A] in accordance with the combination of the crankcase and crankshaft coding.  
Size Color [B]

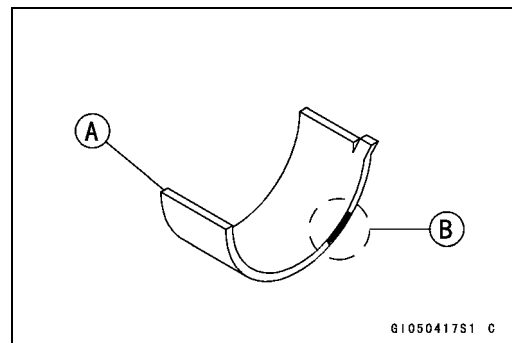

(Engine No. ~ ZX600PE008560)

Crankcase Main Bearing Inside Diameter Marking	Crankshaft Main Journal Diameter Marking	Bearing Insert*		
		Size Color	Part Number	Journal Nos.
○	1	Brown	92139-0173	5
			92139-0191	1, 2, 3, 4
None	1	Black	92139-0172	5
○	None		92139-0190	1, 2, 3, 4
None	None	Blue	92139-0171	5
			92139-0189	1, 2, 3, 4

\*: The bearing inserts for Nos. 1, 2, 3 and 4 journals have an oil groove, respectively.

(Engine No. ZX600PE008561 ~)

Crankcase Main Bearing Inside Diameter Marking	Crankshaft Main Journal Diameter Marking	Bearing Insert*		
		Size Color	Part Number	Journal Nos.
○	1	Brown	92139-0173	3, 5
			92139-0191	1, 2, 4
None	1	Black	92139-0172	3, 5
○	None		92139-0190	1, 2, 4
None	None	Blue	92139-0171	3, 5
			92139-0189	1, 2, 4

\*: The bearing inserts for Nos. 1, 2 and 4 journals have an oil groove, respectively.

- Install the new inserts in the crankcase halves and check insert/journal clearance with the plastigage.

## Pistons

### Piston Removal

- Split the crankcase (see Crankcase Splitting).
- Remove the connecting rod nuts [A] and big end caps [B].

#### NOTE

○ Mark and record the locations of the connecting rods and their big end caps so that they can be reassembled in their original positions.

- Remove:
  - Camshaft Chain [C]
  - Crankshaft [D]
- Remove the connecting rods with pistons to the cylinder head side [E].
- Remove the piston pin snap rings [A].

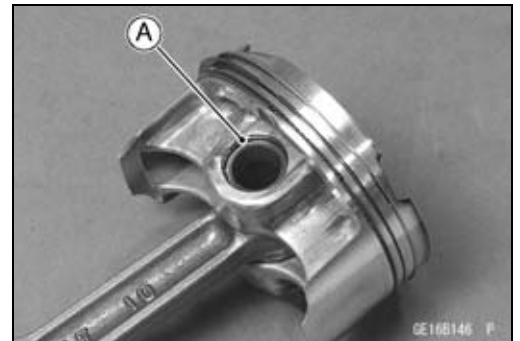
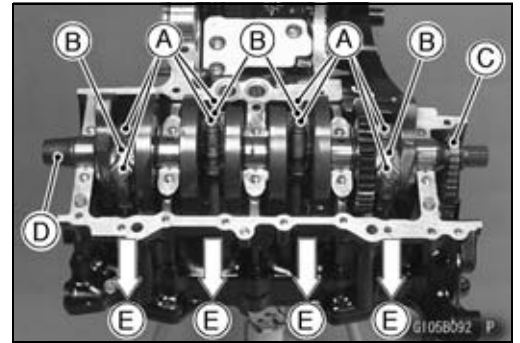

- Using the piston pin puller assembly [A], remove the piston pins.

**Special Tool - Piston Pin Puller Assembly: 57001-910**

- Remove the pistons.

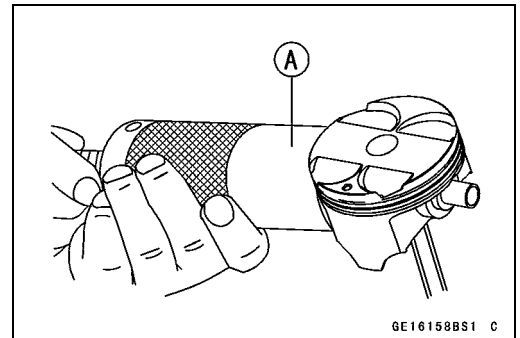

- Carefully spread the ring opening with your thumbs and then push up on the opposite side of the ring [A] to remove it.
- Remove the 3-piece oil ring with your thumbs in the same manner.

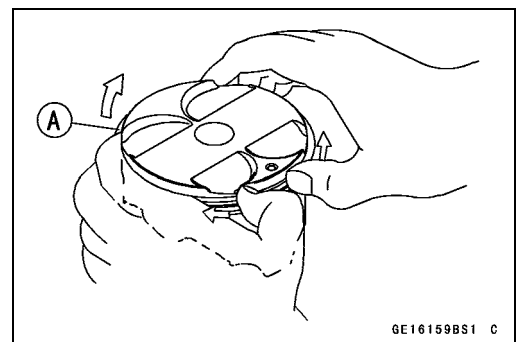

## 9-28 CRANKSHAFT/TRANSMISSION

### Pistons

#### Piston Installation

- Apply molybdenum disulfide oil solution to the oil ring expander, and install the oil ring expander [A] in the bottom piston ring groove so the ends [B] butt together.
- Apply molybdenum disulfide oil solution to the oil ring steel rails, and install the oil ring steel rails, one above the expander and one below it.
- Spread the rail with your thumbs, but only enough to fit the rail over the piston.
- Release the rail into the bottom piston ring groove.

#### NOTE

- The oil ring rails have no "top" or "bottom".

- Do not mix up the top and second ring.
- Install the top ring [A] so that the "R" mark [B] faces up.
- Install the second ring [C] so that the "RN" mark [D] faces up.
- Apply molybdenum disulfide oil solution to the piston rings.

#### NOTE

- If a new piston is used, use new piston ring.

- Fit a new piston pin snap ring into the side of the piston so that the ring opening [A] does not coincide with the slit [B] of the piston pin hole.
- Apply molybdenum disulfide oil solution to the piston pins and piston journals.
- When installing the piston pin snap ring, compress it only enough to install it and no more.

#### CAUTION

**Do not reuse snap rings, as removal weakens and deforms them. They could fall out and score the cylinder wall.**

- The piston ring openings must be positioned as shown in the figure. The openings of the oil ring steel rails must be about 30 ~ 40° of angle from the opening of the top ring.

- Top Ring [A]
- Second Ring [B]
- Oil Ring Steel Rail [C] (Upper)
- Oil Ring Expander [D]
- Oil Ring Steel Rail [E] (Lower)
- Hollow [F]
- 40 ~ 50° [G]

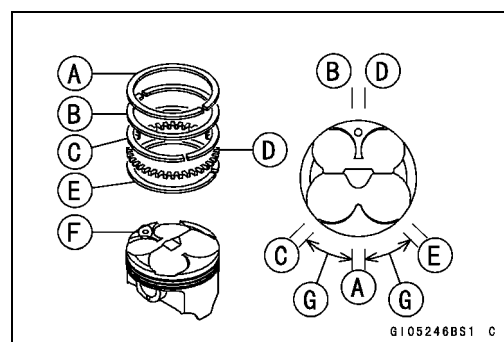
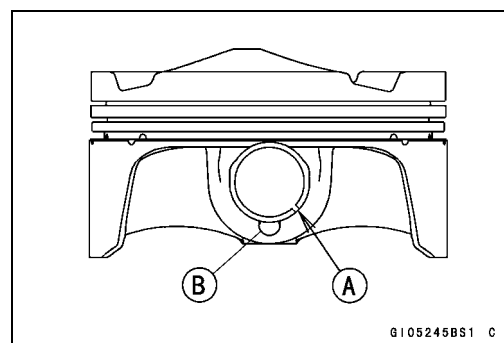
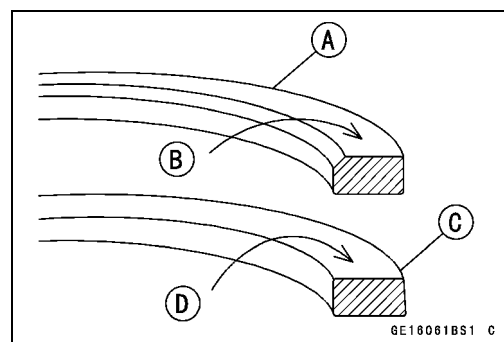
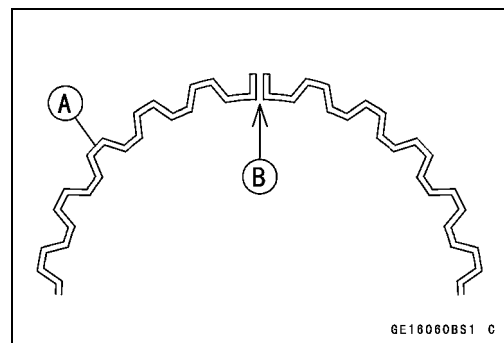



**Pistons**

- Apply molybdenum disulfide oil solution to the cylinder bore, piston skirt and piston rings.
- Install the piston with its marking hollow [A] facing exhaust side.
- Using the piston ring compressor assembly [B] to install the piston from the cylinder head side.

**Special Tools - Piston Ring Compressor Grip: 57001-1095  
Piston Ring Compressor Belt,  $\phi 67 \sim \phi 79$ :  
57001-1097**

- Install:  
Crankshaft (see Crankshaft Installation)  
Connecting Rod Big End Cap (see Connecting Rod Installation)

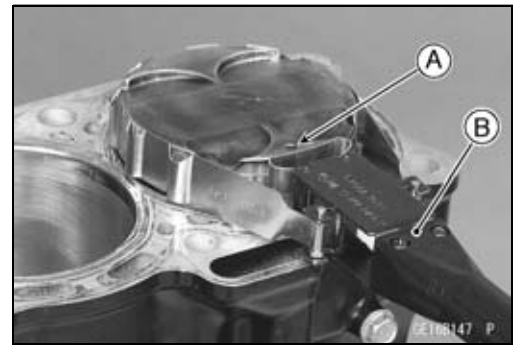

**Cylinder Wear (Upper Crankcase)**

- Since there is a difference in cylinder wear (upper crankcase) in different directions, take a side-to-side and a front-to-back measurement at each of the two locations (total of four measurements) shown in the figure.
- ★ If any of the cylinder inside diameter measurements exceeds the service limit, replace the crankcase.
  - 10 mm (0.39 in.) [A]
  - 60 mm (2.36 in.) [B]

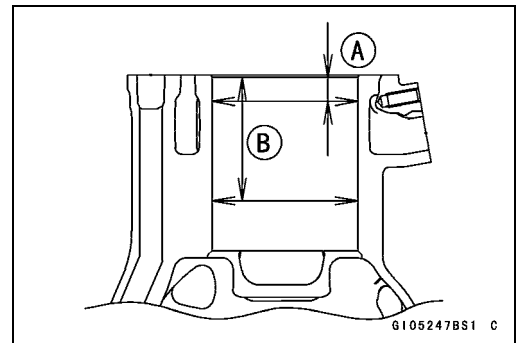

**Cylinder Inside Diameter**

**Standard: 67.000 ~ 67.012 mm (2.6378 ~ 2.6383 in.)**  
**Service Limit: 68.09 mm (2.64 in.)**

**Piston Wear**

- Measure the outside diameter [A] of each piston 5 mm (0.20 in.) [B] up from the bottom of the piston at a right angle to the direction of the piston pin.
- ★ If the measurement is under service limit, replace the piston.

**Piston Diameter**

**Standard: 66.975 ~ 66.990 mm (2.6368 ~ 2.6374 in.)**  
**Service Limit: 66.83 mm (2.631 in.)**

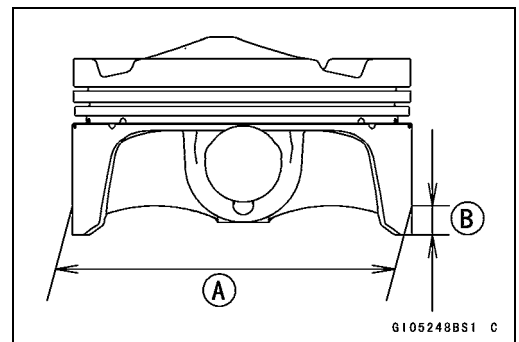

**Piston Ring, Piston Ring Groove Wear**

- Check for uneven groove wear by inspecting the ring seating.
- ★ The rings should fit perfectly parallel to groove surfaces. If not, replace the piston and all the piston rings.
- With the piston rings in their grooves, make several measurements with a thickness gauge [A] to determine piston ring/groove clearance.

**Piston Ring/Groove Clearance**

**Standard:**

**Top 0.05 ~ 0.09 mm (0.0020 ~ 0.0035 in.)**  
**Second 0.03 ~ 0.07 mm (0.0012 ~ 0.0028 in.)**

**Service Limit:**

**Top 0.19 mm (0.0075 in.)**  
**Second 0.17 mm (0.0067 in.)**

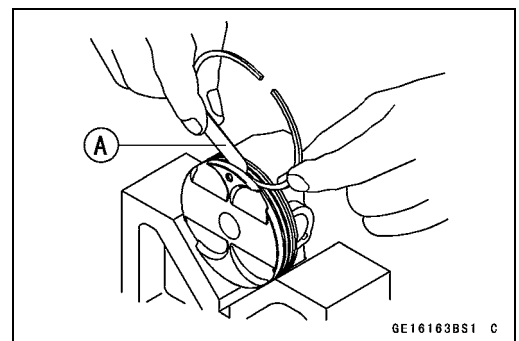

## 9-30 CRANKSHAFT/TRANSMISSION

### Pistons

#### Piston Ring Groove Width

- Measure the piston ring groove width.
- Use a vernier caliper at several points around the piston.

##### Piston Ring Groove Width

###### Standard:

Top [A] 0.84 ~ 0.86 mm (0.0331 ~ 0.0339 in.)

Second [B] 0.82 ~ 0.84 mm (0.0323 ~ 0.0331 in.)

###### Service Limit:

Top [A] 0.94 mm (0.037 in.)

Second [B] 0.92 mm (0.036 in.)

- ★ If the width of any of the two grooves is wider than the service limit at any point, replace the piston.

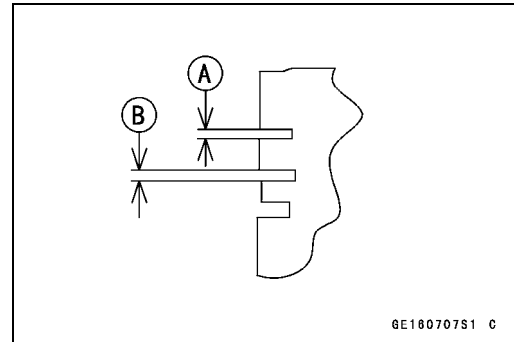

#### Piston Ring Thickness

- Measure the piston ring thickness.
- Use the micrometer to measure at several points around the ring.

##### Piston Ring Thickness

###### Standard:

Top [A] 0.77 ~ 0.79 mm (0.0303 ~ 0.0311 in.)

Second [B] 0.77 ~ 0.79 mm (0.0303 ~ 0.0311 in.)

###### Service Limit:

Top [A] 0.70 mm (0.028 in.)

Second [B] 0.70 mm (0.028 in.)

- ★ If any of the measurements is less than the service limit on either of the rings, replace all the rings.

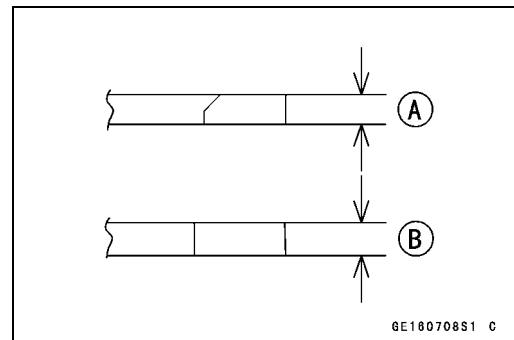

#### NOTE

- When using new rings in a used piston, check for uneven groove wear. The rings should fit perfectly parallel to the groove sides. If not, replace the piston.

#### Piston Ring End Gap

- Place the piston ring [A] inside the cylinder (upper crankcase), using the piston to locate the ring squarely in place. Set it close to the bottom of the cylinder, where cylinder wear is low.
- Measure the gap [B] between the ends of the ring with a thickness gauge.

##### Piston Ring End Gap

###### Standard:

Top 0.12 ~ 0.22 mm (0.0047 ~ 0.0087 in.)

Second 0.30 ~ 0.45 mm (0.0118 ~ 0.0177 in.)

###### Service Limit:

Top 0.5 mm (0.020 in.)

Second 0.8 mm (0.031 in.)

- ★ If the end gap of either ring is greater than the service limit, replace all the rings.

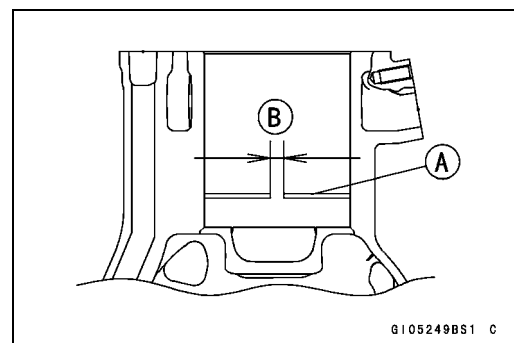

**Starter Idle Gear and Starter Clutch**

**Starter Idle Gear Removal**

- Remove:
  - Right Middle Fairing (see Right Middle Fairing Removal in the Frame chapter)
  - Heat Insulation Cover [A]
  - Bolts [B]
  - Idle Gear Cover [C]

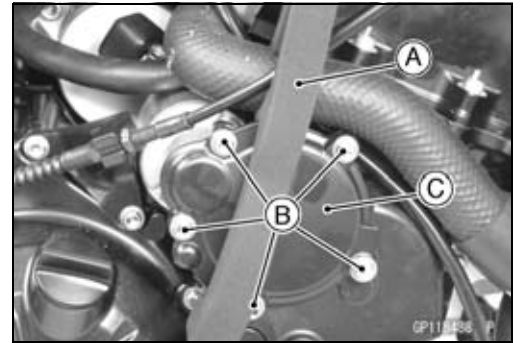

- Pull out the idle gear (starter motor side) [A] with the shaft [B].

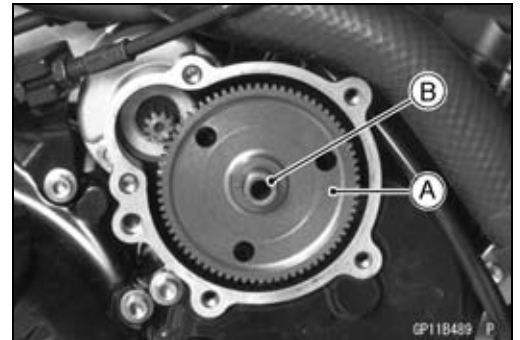

- Remove:
  - Bolts [A]
  - Bracket [B]
  - Starter Clutch Cover [B]

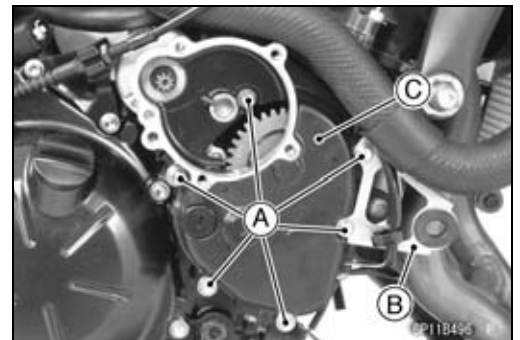

- Pull out the idle gear (starter clutch side) [A] with the shaft [B].

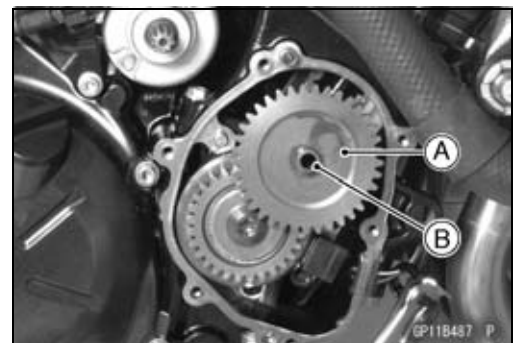

**Starter Idle Gear Installation**

- Apply molybdenum disulfide grease [A] to the idle gear shaft (starter clutch side) [B].
- Fit the pin [C] into the groove [D] of the crankcase.

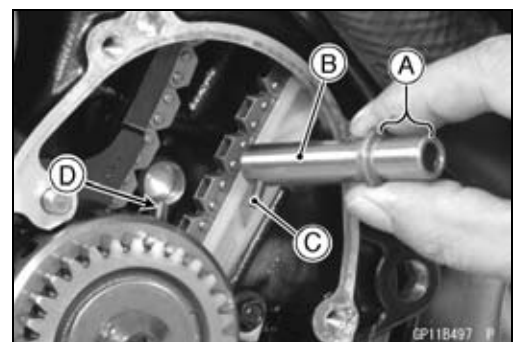

## 9-32 CRANKSHAFT/TRANSMISSION

### Starter Idle Gear and Starter Clutch

- Install the idle gear (starter clutch side) [A] on the shaft.
  - Engage the idle gear with the starter clutch gear.
  - Apply silicone sealant to the following portion.
    - Crankshaft Sensor Lead Grommet [B]
    - Crankcase Halves Mating Surfaces [C]
- Sealant - Kawasaki Bond (Silicone Sealant): 92104-0004**
- Install the dowel pins [D] and new gasket.

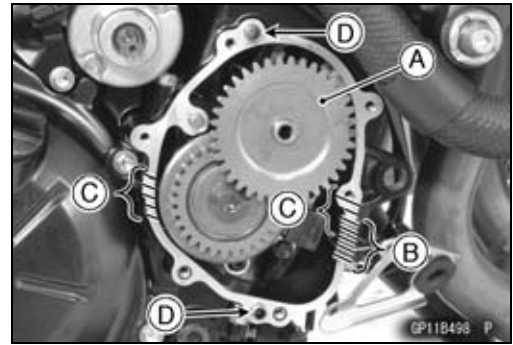

- Apply grease to the O-rings of starter motor.
- Install:
  - Starter Clutch Cover [A]
  - Bracket [B]
- Tighten:
  - **Torque - Starter Clutch Cover Bolts: 9.8 N·m (1.0 kgf·m, 87 in·lb)**
    - L = 20 mm (0.79 in.) [C]
    - L = 30 mm (1.18 in.) [D]

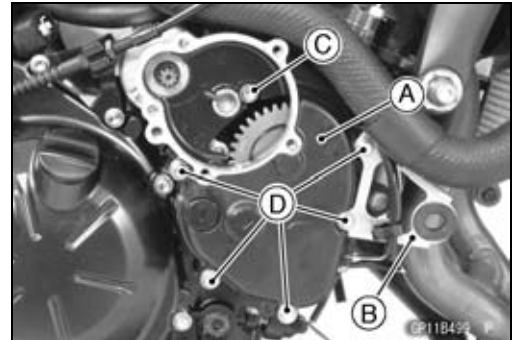

- Apply molybdenum disulfide grease to the idle gear shaft (starter motor side) [A].
- Install the idle gear (starter motor side) [B] on the shaft.
- Engage the idle gear with the starter motor gear and idle gear (starter clutch side).
- Fit the pin [C] into the groove [D] of the starter clutch cover.
- Install the dowel pin [E] and new gasket.

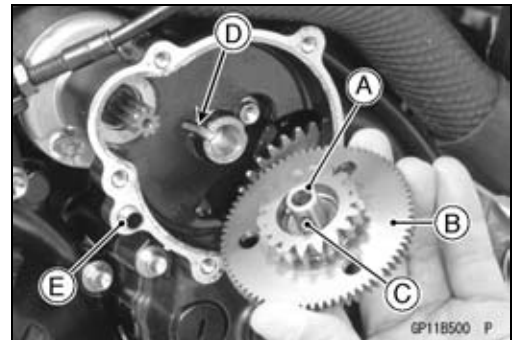

- Position the idle gear [A] to inside of the mating surface [B] of the cover.

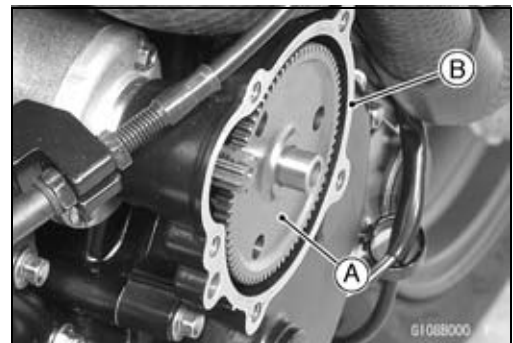

- Install:
  - Idle Gear Cover [A]
  - Idle Gear Cover Bolts [B]
  - Idle Gear Cover Bolts [C] with Gaskets
- Tighten:
  - **Torque - Idle Gear Cover Bolts: 9.8 N·m (1.0 kgf·m, 87 in·lb)**
- Install the removed parts (see appropriate chapters).

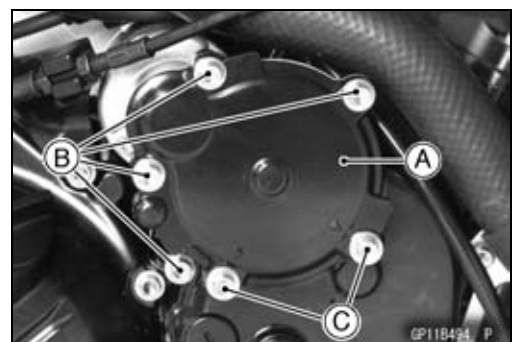

**Starter Idle Gear and Starter Clutch**

**Starter Clutch Removal**

- Remove:
  - Alternator Cover (see Alternator Cover Removal in the Electrical System chapter)
  - Starter Clutch Cover (see Idle Gear Removal)
  - Idle Gear (Starter Clutch Side, see Idle Gear Removal)
- Unscrew the starter clutch bolt [A], while holding the alternator rotor steady with the rotor holder (see Alternator Rotor Removal in the Electrical System chapter).

**Special Tools - Grip: 57001-1591**  
**Stopper: 57001-1679**  
**Rotor Holder: 57001-1666**

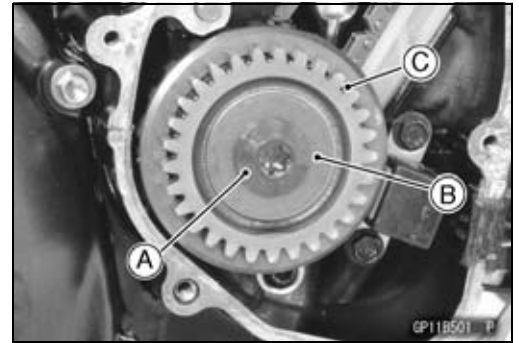

- Remove:
  - Washer [B]
  - Starter Clutch [C]

**Starter Clutch Installation**

- Install the starter clutch [A] while fitting the alignment notch [B] of the splines onto the alignment tooth [C].
- Install the washer.
- Tighten the starter clutch bolt, while holding the alternator rotor steady with the rotor holder (see Alternator Rotor Installation in the Electrical System chapter).

**Special Tools - Grip: 57001-1591**  
**Stopper: 57001-1679**  
**Rotor Holder: 57001-1666**

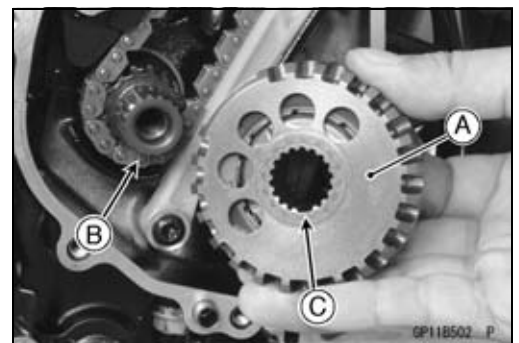

**Torque - Starter Clutch Bolt: 49 N·m (5.0 kgf·m, 36 ft·lb)**

- Install the removed parts (see appropriate chapters).

**Starter Clutch Disassembly**

- Remove:
  - Starter Clutch (see Starter Clutch Removal)
- Pull the starter clutch gear [A] out of the starter clutch [B].
- Remove:
  - Needle Bearing [C]

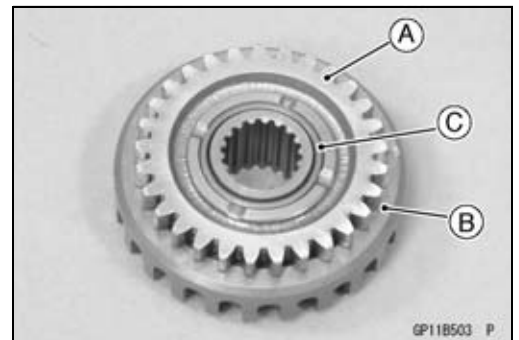

- Remove:
  - Snap Ring [A]
- Pull the one-way clutch [B] out of the starter clutch case [C].

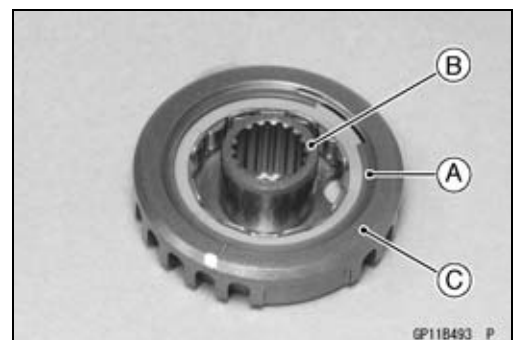

## 9-34 CRANKSHAFT/TRANSMISSION

### Starter Idle Gear and Starter Clutch

#### Starter Clutch Assembly

- Install the one-way clutch [A] so that its circlip side [B] faces in.
- Install the new snap ring.

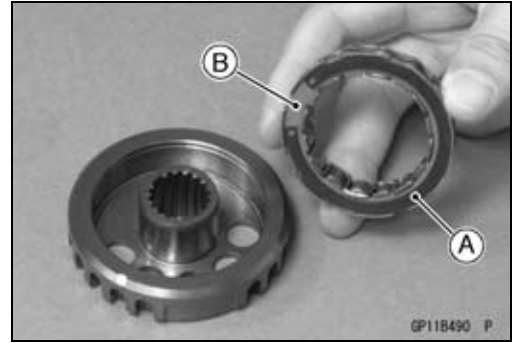

- Push [A] the starter clutch gear [B] in and turn it counterclockwise [C] and install it.

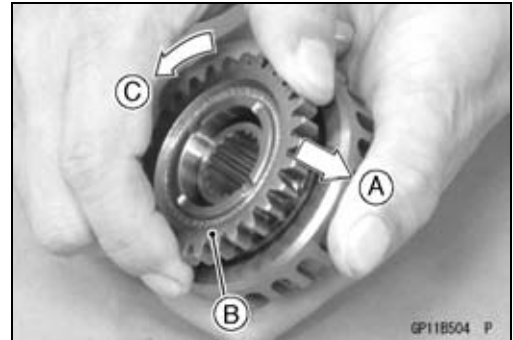

- Apply molybdenum disulfide oil solution to the needle bearing [A], and install it.

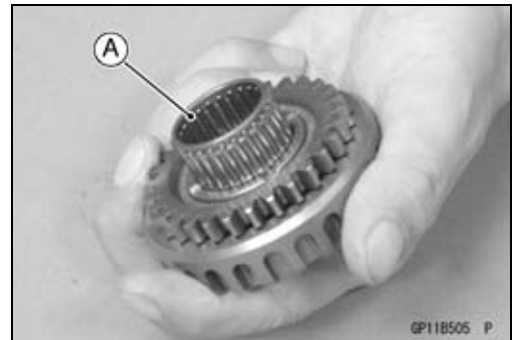

#### Starter Clutch Inspection

- Remove:
  - Starter Clutch Cover (see Idle Gear Removal)
  - Idle Gear (Starter clutch side, see Idle Gear Removal)
- Turn the starter clutch gear [A] by hand. The starter clutch gear should turn counterclockwise freely [B], but should not turn clockwise.
- ★ If the starter clutch does not operate as it should or if it makes noise, go to the next step.
- Disassemble the starter clutch, and visually inspect the clutch parts.
  - One-way Clutch [A]
  - Starter Clutch Case [B]
- ★ If there is any worn or damaged part, replace it.

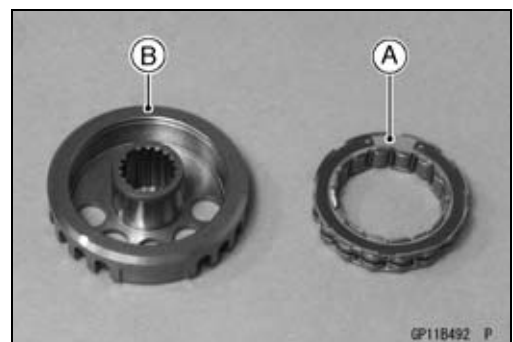
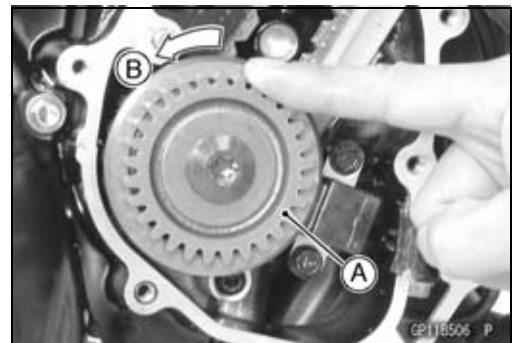

### Starter Idle Gear and Starter Clutch

---

○Examine the starter clutch gear [C] as well. Replace the clutch gear if it is worn or damaged.

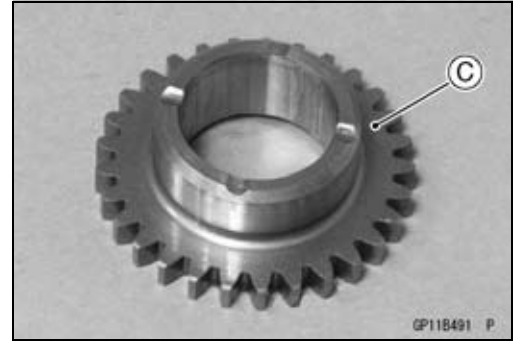

## 9-36 CRANKSHAFT/TRANSMISSION

### Transmission

#### Shift Pedal Removal

- Remove:
  - Shift Lever Bolt [A]
  - Shift Pedal Mounting Bolt [B]
  - Tie-Rod [C] and Shift Pedal [D]

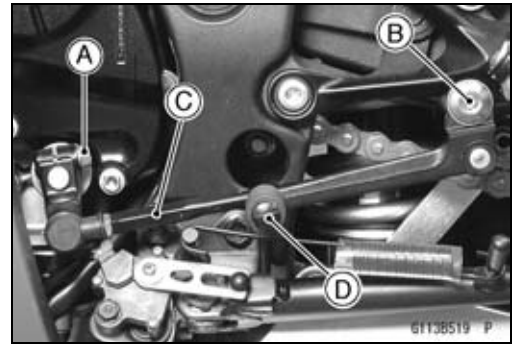

#### Shift Pedal Installation

- Apply grease to the sliding surface [A] on the shift pedal mounting bolt [B].
- Install:
  - Washers [C]
  - Shift Pedal Assembly [D]
- The front side of the tie-rod has the grooves [E].
- The grooves side of the tie-rod and front locknut [F] have left-hand threads.
- Tighten:

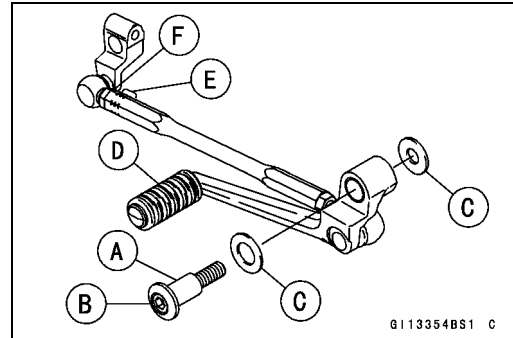

**Torque - Shift Pedal Mounting Bolt: 25 N·m (2.5 kgf·m, 18 ft·lb)**

- Align the punch mark [A] on the shift shaft with the slit [B] of the shift lever.
- Tighten:

**Torque - Shift Lever Bolt [C]: 6.9 N·m (0.70 kgf·m, 61 in·lb)**

- Install the shift pedal as follows.
  - About 90° [D]
  - About 95° [E]
  - 1 ~ 3 mm (0.04 ~ 0.12 in.) [F] (The length is distance between the center line of the tie-rod [G] and center in the shift pedal end.)
- To adjust the pedal position, loosen the locknuts [H] and then turn the tie-rod.

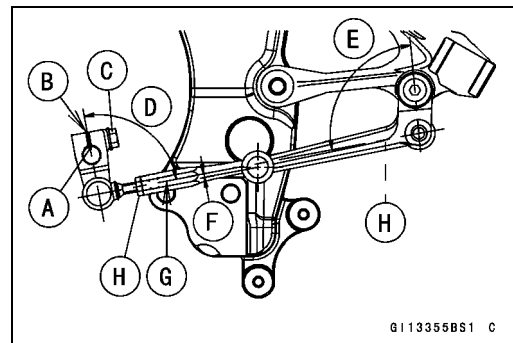

- Tighten:

**Torque - Shift Tie-Rod Locknuts: 6.9 N·m (0.70 kgf·m, 61 in·lb)**

#### External Shift Mechanism Removal

- Remove:
  - Engine Oil (see Drain, Engine Oil Change in the Periodic Maintenance chapter)
  - Shift Pedal (see Shift Pedal Removal)
  - Circlip [A]
  - Washer [B]

**Special Tool - Outside Circlip Pliers: 57001-144**

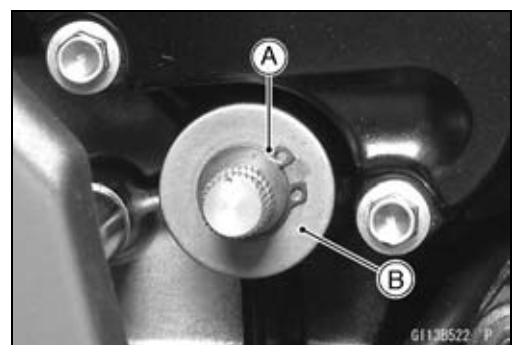



**Transmission**

- Remove:
  - Clutch (see Clutch Removal in the Clutch chapter)
- Remove the shift shaft assembly [A] while pulling the shift mechanism arm.

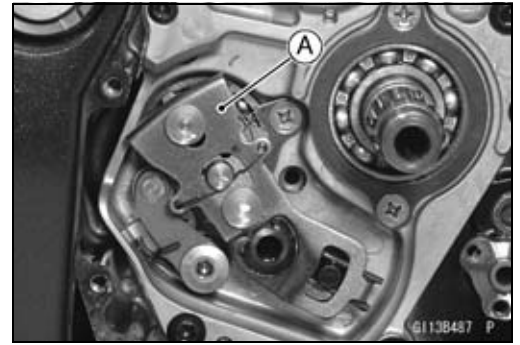

- Remove:
  - Gear Positioning Lever Bolt [A]
  - Gear Positioning Lever [B], Collar and Spring

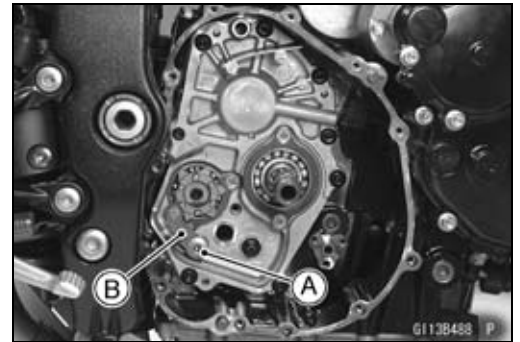

**External Shift Mechanism Installation**

- Install the gear positioning lever [A] as shown.
  - Spring [B]
  - Collar [C]
  - Bolt [D]
- Tighten:
  - Torque - Gear Positioning Lever Bolt: 12 N·m (1.2 kgf·m, 106 in·lb)**

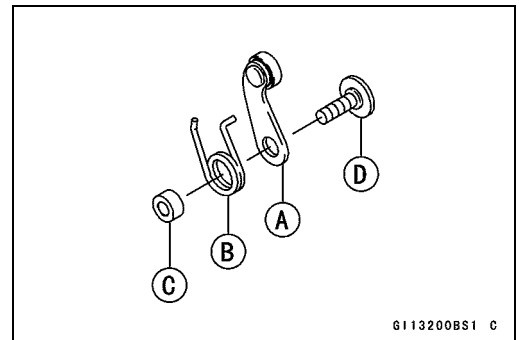

- Install:
  - Washer [A]
  - Shift Shaft Assembly [B]
- Install the spring [C] and shift mechanism arm [D] on the return spring pin [E].
- Install:
  - Washer [F]
  - Circlip [G]
- Special Tool - Outside Circlip Pliers: 57001-144**

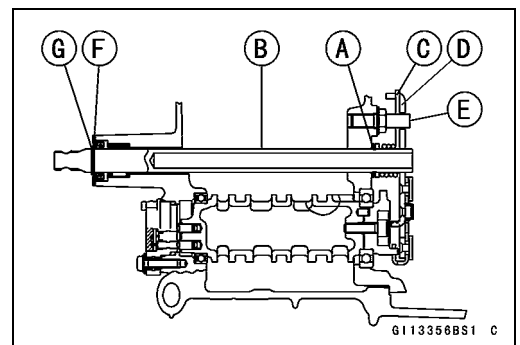

**External Shift Mechanism Inspection**

- Examine the shift shaft [A] for any damage.
  - ★ If the shaft is bent, replace it.
  - ★ If the serration [B] are damaged, replace the shaft.
  - ★ If the springs [C] are damaged in any way, replace them.
  - ★ If the shift mechanism arm [D] is damaged in any way, replace the shift shaft.

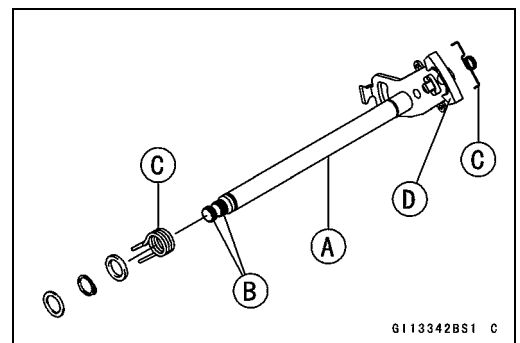

## 9-38 CRANKSHAFT/TRANSMISSION

### Transmission

- Check the return spring pin [A] is not loose.
- ★ If it is loose, unscrew it, apply a non-permanent locking agent to the threads, and tighten it.

**Torque - Shift Shaft Return Spring Pin: 28 N·m (2.9 kgf·m, 21 ft·lb)**

- Check the gear positioning lever [B] and its spring for breaks or distortion.
- ★ If the lever or spring are damaged in any way, replace them.
- Visually inspect the shift drum cam [C].
- ★ If they are badly worn or if they show any damage, replace it.

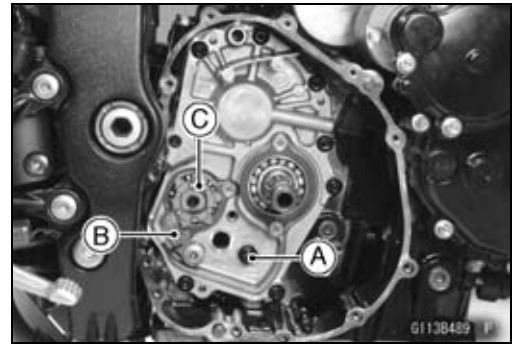

### Transmission Assy Removal

- Remove:
  - Engine Sprocket (see Engine Sprocket Removal in the Final Drive chapter)
  - Gear Position Switch (see Gear Position Switch Removal in the Electrical System chapter)
  - Collar [A]
  - O-ring [B]

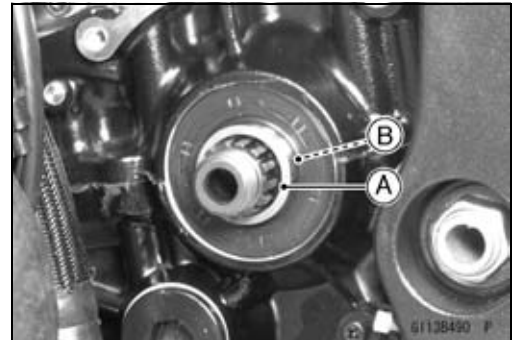

- Remove:
  - Clutch (see Clutch Removal in the Clutch chapter)
  - Shift Shaft Assembly (see External Shift Mechanism Removal)
  - Transmission Case Bolts [A]
- ★ If the transmission assy is to be disassembled, remove the following:
  - Gear Positioning Lever Bolt [B]
  - Gear Positioning Lever [C], Spring and Collar

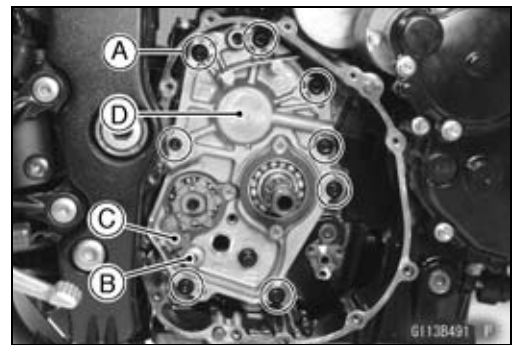

- Pull the transmission assy [D] out of the crankcase.

### Transmission Assy Disassembly

- Remove the transmission assy (see Transmission Assy Removal).
- Remove the following from the transmission case [A].
  - Shift Rods [B]
  - Shift Forks [C]
  - Drive Shaft [D]
  - Output Shaft [E]

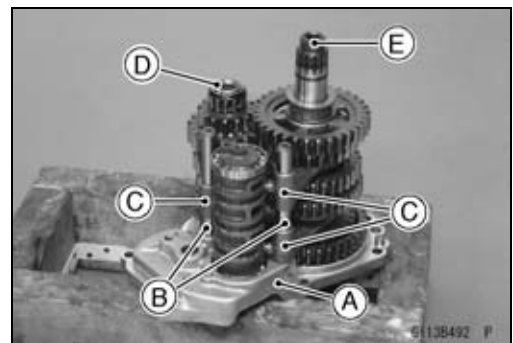

**Transmission**

- Remove:
  - Gear Positioning Lever [A]
  - Bearing Holder Screws [B]
  - Bearing Holder [C]
  - Shift Drum Assembly [D]

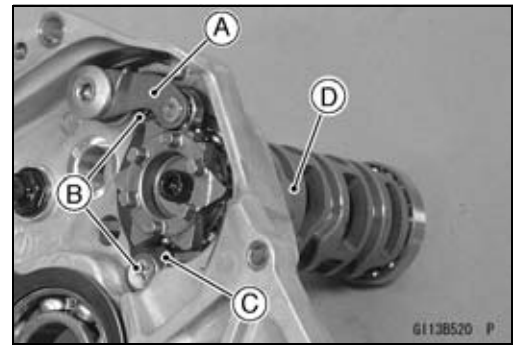

**Transmission Assy Assembly**

- Press and insert the race [A] in the transmission case [B] so that the big stepped side [C] faces to transmission gears side until it is bottomed.

**Special Tool - Bearing Driver Set: 57001-1129**

- Install the race holder [D] as shown in the figure.
- Apply a non-permanent locking agent to the race holder screw [E].
- Tighten:

**Torque - Race Holder Screw: 4.9 N·m (0.50 kgf·m, 43 in·lb)**

- Press and insert the dowel pins [F] in the transmission case until they are bottomed.

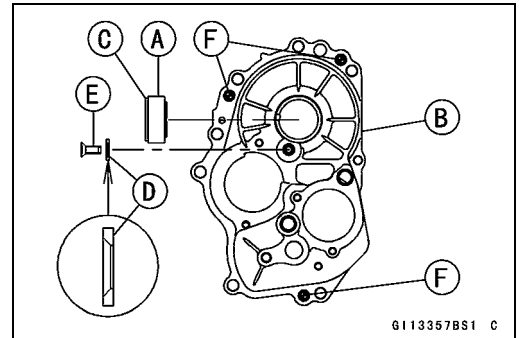

- Press and insert the ball bearing [A] in the transmission case [B] so that the stepped side faces outside until it is bottomed.

- Install the bearing holder [C] as shown in the figure.
- Apply a non-permanent locking agent to the bearing holder screw [D].

- Tighten:

**Torque - Bearing Holder Screw: 4.9 N·m (0.50 kgf·m, 43 in·lb)**

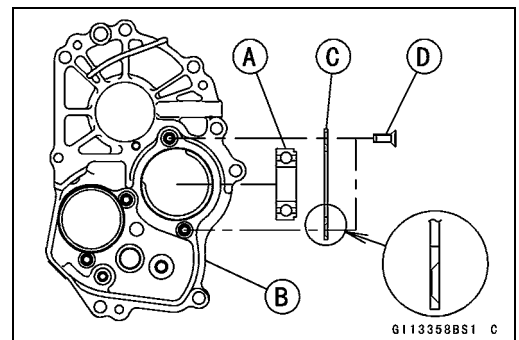

- Install:
  - Shift Drum Assembly [A]
  - Bearing Holder

- Install the bearing holder so that the taper side faces outside.

- Apply a non-permanent locking agent to the bearing holder screws [C].

- Tighten:

**Torque - Bearing Holder Screws: 4.9 N·m (0.50 kgf·m, 43 in·lb)**

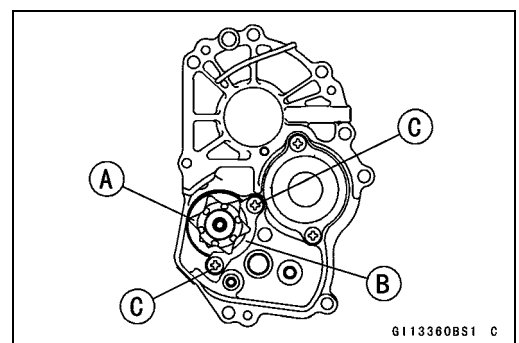

## 9-40 CRANKSHAFT/TRANSMISSION

### Transmission

- Install the drive shaft [A] and output shaft [B] as a set in the transmission case [C].
- Install the shift forks as shown in the figure.
- The shift fork [D] for drive shaft gears has the short ears.
- The shift forks [E] [F] for output shaft gears have the long ears.
- The shift fork [E] has R mark [F].
- The shift fork [G] has L mark [H].
- Install the shift rods so that the ends of the rods are same height.
- The shift rod [I] of the drive shaft side is shorter than the shift rod [J] of output shaft side.
- Apply molybdenum disulfide solution to the transmission gears (x marks) [K].
- Install the spacer [L] on the output shaft.
- Apply grease to the O-ring [M] and install it to its position on the output shaft.

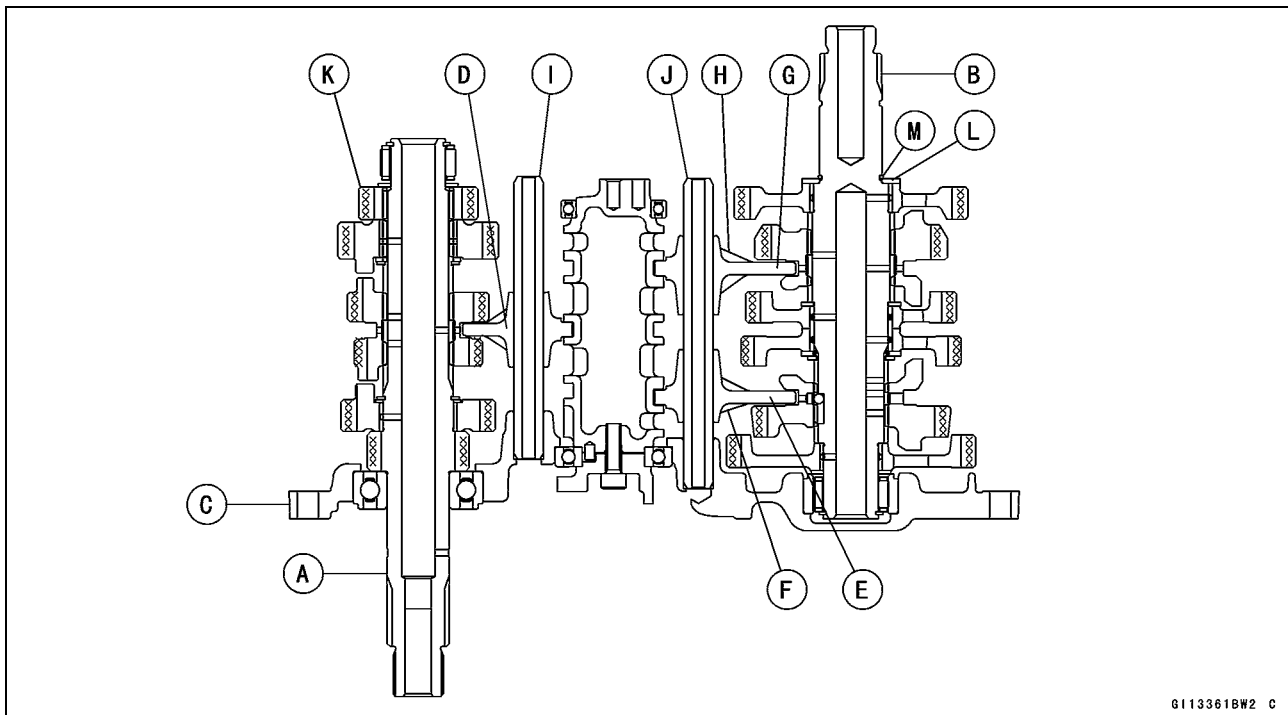

### Transmission Assy Installation

- Assemble the transmission assy (see Transmission Assy Assembly).
- Be sure that the dowel pins are in position.
- Install the transmission assy on the crankcase.
- Tighten the transmission case bolts.

**Torque - Transmission Case Bolts (M8) [A]: 20 N·m (2.0 kgf·m, 15 ft·lb)**

**Transmission Case Bolts (M6) [B]: 9.8 N·m (1.0 kgf·m, 87 in·lb)**

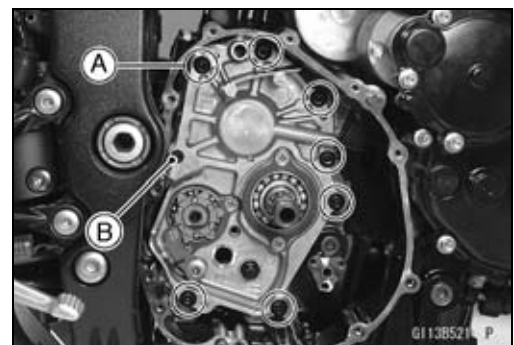

## Transmission

- Install the gear positioning lever (see External Shift Mechanism Installation).
- Set the gear positioning lever to the neutral position [A].
- Check that the drive and output shaft turn freely.

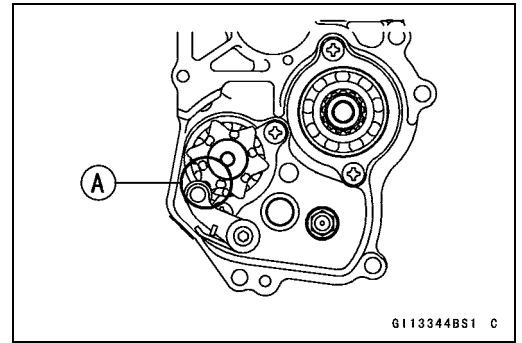

- Apply grease to the O-ring [A] and install it to its position on the output shaft [B].
- Install the collar [C].
- When installing the oil seal [D], install it as follows.
  - Apply grease to the lip of the oil seal.
  - Apply oil to the outer circumference of the oil seal so that it will go into place smoothly.
  - Press and insert the oil seal in the crankcase so that the surface of the oil seal is flush with the surface of the crankcase as shown in the figure.

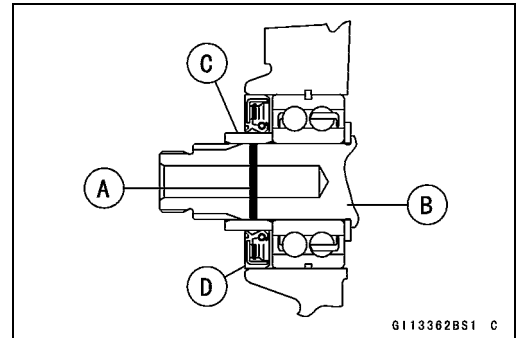

- Install:
  - Gear Position Switch (see Gear Position Switch Installation in the Electrical System chapter)
  - Removed Parts

### Transmission Shaft Removal

- Remove the transmission assy (see Transmission Assy Removal).
- Remove:
  - Shift Rods [A]
  - Shift Forks [B]
  - Drive Shaft [C] and Output Shaft [D]

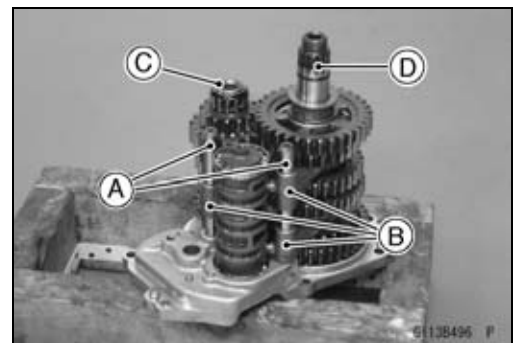

### Transmission Shaft Installation

- Be sure that the spacer [A] is on the output shaft [B].

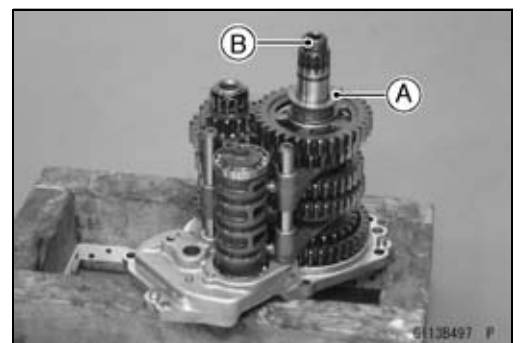

- Install the transmission assy on the crankcase (see Transmission Assy Installation).

## 9-42 CRANKSHAFT/TRANSMISSION

### Transmission

#### **Transmission Shaft Disassembly**

- Remove the transmission shafts (see Transmission Shaft Removal).
- Remove the circlips, disassemble the transmission shafts.

#### **Special Tool - Outside Circlip Pliers: 57001-144**

- The 5th gear [A] on the output shaft has three steel balls assembled into it for the positive neutral finder mechanism. Remove the 5th gear.
- Set the output shaft in a vertical position holding the 3rd gear [C].
- Spin the 5th gear quickly [B] and pull it off upward.

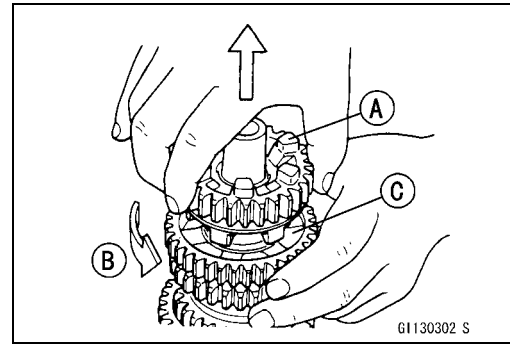

#### **Transmission Shaft Assembly**

- Apply molybdenum disulfide oil to the sliding surfaces of the gears and shafts.
- Install the gear bushings [A] on the shaft with their holes [B] aligned.

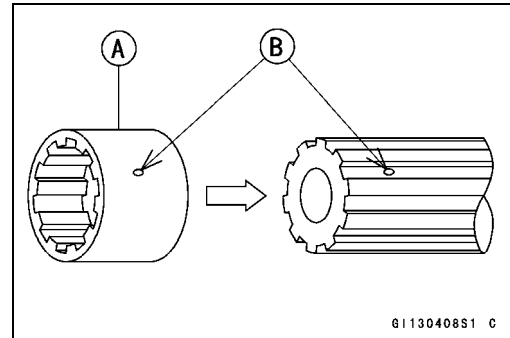

- Replace any circlips removed with new ones.
- Install the circlip [A] on the drive shaft [B] so that the punch mark [C] faces the washer [D] and position the opening [E] as shown in the figure.

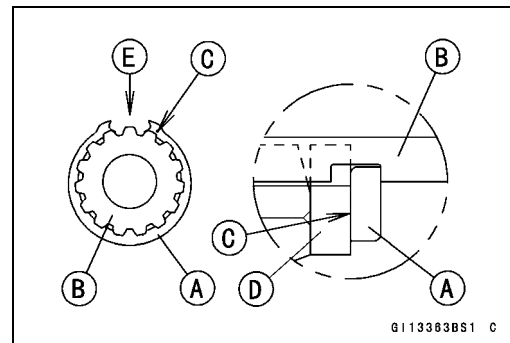

- Install the circlip [A] on the output shaft [B] so that the punch mark [C] faces the washer [D] and position the opening [E] as shown in the figure.

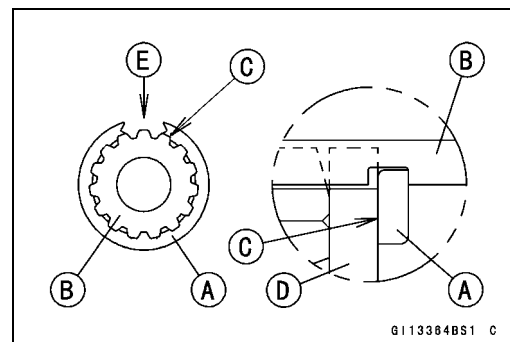

**Transmission**

- The drive shaft gears can be recognized by size: the gear with the smallest diameter is 1st gear, and the largest one is 6th gear. Be sure that all parts are put back in the correct sequence and all circlips and washers are properly in place.
- Install the 3rd/4th gear onto the drive shaft with their oil holes aligned.
- The output shaft gears can be recognized by size: the gear with the largest diameter is 1st gear, and the smallest one is 6th gear. Be sure that all parts are put back in the correct sequence and all circlips and washers are properly in place.
- Install the 5th and 6th gears onto the output shaft with their oil holes aligned.
- Fit the steel balls into the 5th gear holes in the output shaft, aligning three oil holes.
  - 5th Gear [A]
  - Output Shaft [B]
  - Steel Balls [C]
  - Oil Holes [D]

**CAUTION**

**Do not apply grease to the balls to hold them in place. This will cause the positive neutral finder mechanism to malfunction.**

- After assembling the 5th gear with steel balls in place on the output shaft, check the ball-locking effect that the 5th gear doesn't come out of the output shaft when moving it up and down by hand.
- Check that each gear spins or slides freely on the transmission shafts after assembly.
- ★ If it is not smooth, replace the damaged parts.

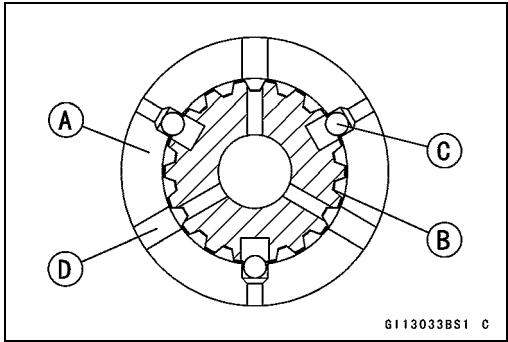

# 9-44 CRANKSHAFT/TRANSMISSION

## Transmission

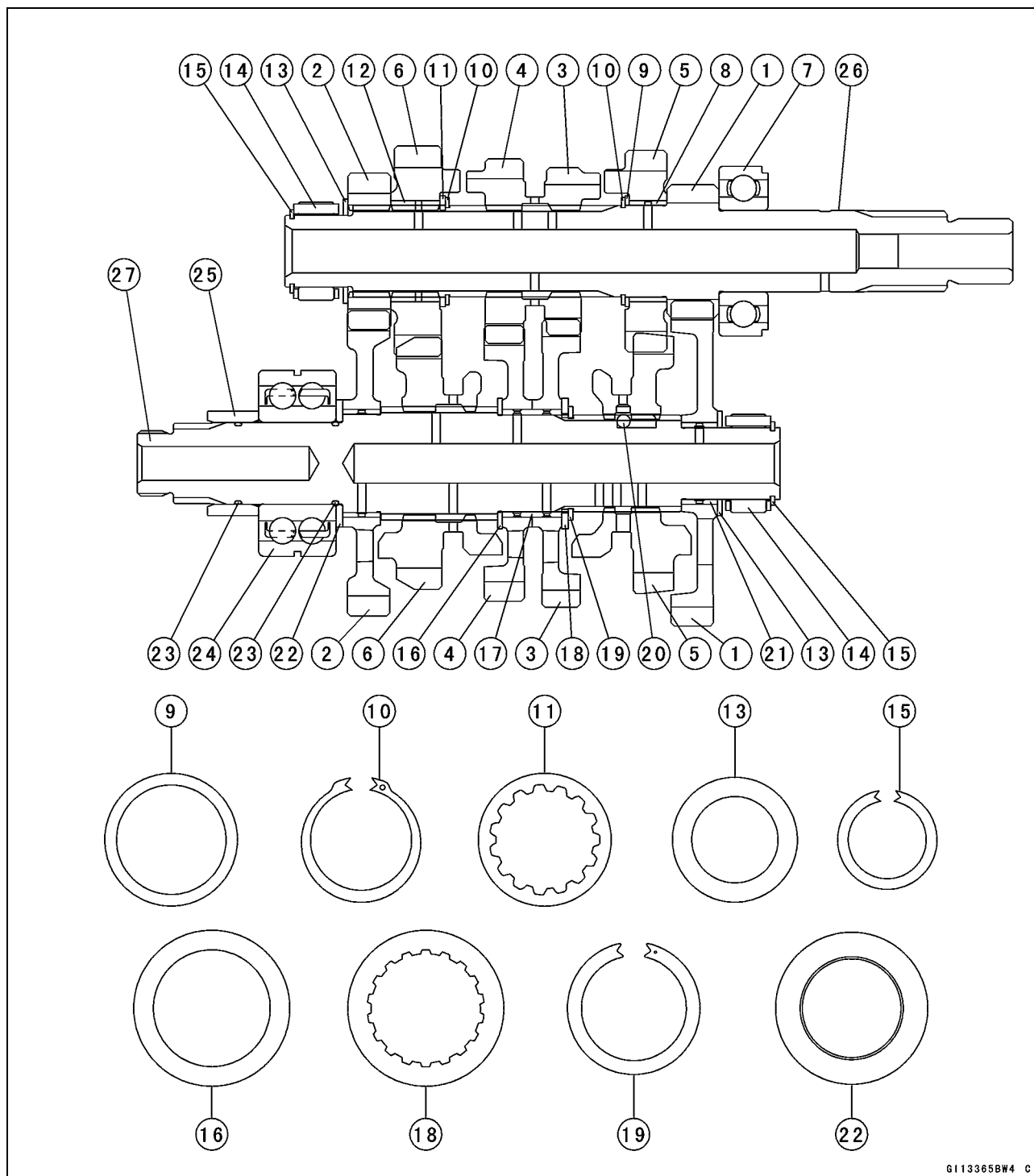

6113365BW4 C

- |   |   |
|---|---|
| 1. 1st Gear                                 | 15. Circlip                                 |
| 2. 2nd Gear                                 | 16. Water, $\phi 40$ mm (1.57 in.)          |
| 3. 3rd Gear                                 | 17. Bushing                                 |
| 4. 4th Gear                                 | 18. Toothed Washer, $\phi 40$ mm (1.57 in.) |
| 5. 5th Gear                                 | 19. Circlip                                 |
| 6. 6th (Top) Gear                           | 20. Steel Ball                              |
| 7. Ball Bearing                             | 21. Bushing                                 |
| 8. Bushing                                  | 22. Spacer                                  |
| 9. Washer, $\phi 34$ mm (1.34 in.)          | 23. O-ring                                  |
| 10. Circlip                                 | 24. Ball Bearing                            |
| 11. Toothed Washer, $\phi 34$ mm (1.34 in.) | 25. Collar                                  |
| 12. Bushing                                 | 26. Drive Shaft                             |
| 13. Washer, $\phi 32$ mm (1.26 in.)         | 27. Output Shaft                            |
| 14. Needle Bearing                          |   |



**Transmission**

**Shift Drum and Fork Removal**

- Remove the transmission assy (see Transmission Assy Removal).
- Remove the shift forks [A] and shift drum [B] (see Transmission Assy Disassembly).

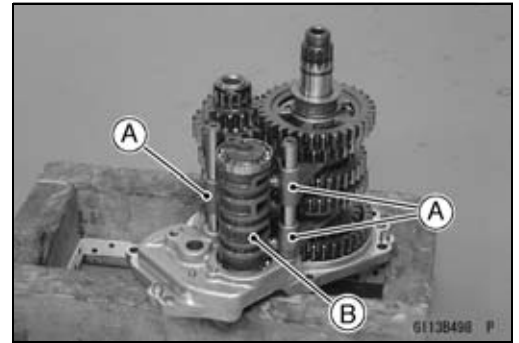

**Shift Drum and Fork Installation**

- Refer to the Transmission Assy Assembly and Installation.

**Shift Drum Disassembly**

- Remove the shift drum (see Transmission Assy Disassembly).
- While holding the shift drum with a vise, remove the shift drum cam holder bolt [A].
- Remove:
  - Shift Drum Cam [B]
  - Dowel Pin [C]
  - Ball Bearings [D]
  - Shift Drum [E]

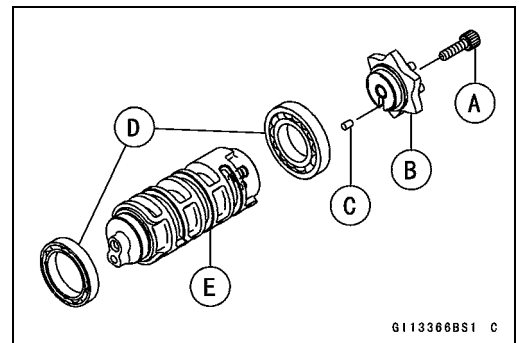

**Shift Drum Assembly**

- Press and insert the ball bearing [A] on the shift drum [B] until it is bottomed.
- Install:
  - Ball Bearing [C]
  - Pin [D] and Shift Drum Cam [E]
- Align the pin with the groove in the shift drum cam.
- Apply a non-permanent locking agent to the shift drum cam holder bolt [F] and tighten it.

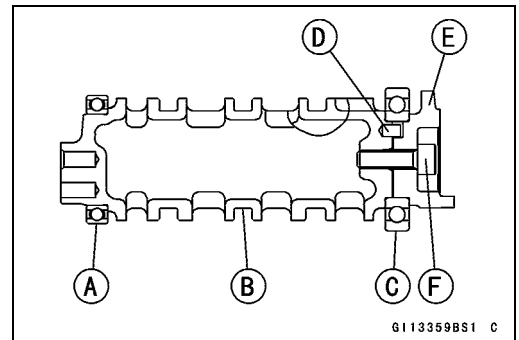

**Torque - Shift Drum Cam Holder Bolt: 12 N-m (1.2 kgf-m, 106 in-lb)**

**Shift Fork Bending**

- Visually inspect the shift forks, and replace any fork that is bent. A bent fork could cause difficulty in shifting, or allow the transmission to jump out of gear when under power. 90° [A]

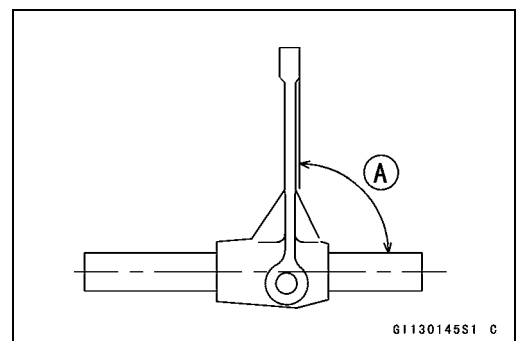

## 9-46 CRANKSHAFT/TRANSMISSION

### Transmission

#### **Shift Fork/Gear Groove Wear**

- Measure the thickness of the shift fork ears [A], and measure the width [B] of the gear grooves.
- ★ If the thickness of a shift fork ear is less than the service limit, the shift fork must be replaced.

##### **Shift Fork Ear Thickness**

**Standard:** 5.9 ~ 6.0 mm (0.232 ~ 0.236 in.)

**Service Limit:** 5.8 mm (0.228 in.)

- ★ If the gear groove is worn over the service limit, the gear must be replaced.

##### **Gear Groove Width**

**Standard:** 6.05 ~ 6.15 mm (0.238 ~ 0.242 in.)

**Service Limit:** 6.25 mm (0.246 in.)

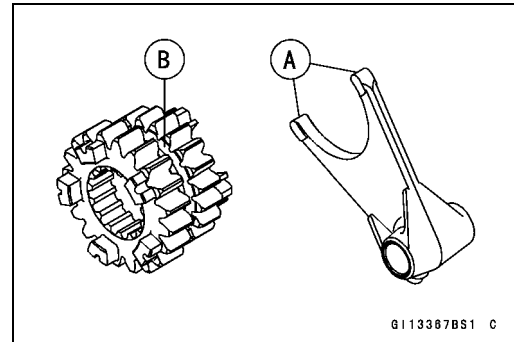

#### **Shift Fork Guide Pin/Drum Groove Wear**

- Measure the diameter of each shift fork guide pin [A], and measure the width [B] of each shift drum groove.
- ★ If the guide pin on any shift fork is less than the service limit, the fork must be replaced.

##### **Shift Fork Guide Pin Diameter**

**Standard:** 5.9 ~ 6.0 mm (0.232 ~ 0.236 in.)

**Service Limit:** 5.8 mm (0.228 in.)

- ★ If any shift drum groove is worn over the service limit, the drum must be replaced.

##### **Shift Drum Groove Width**

**Standard:** 6.05 ~ 6.20 mm (0.238 ~ 0.244 in.)

**Service Limit:** 6.3 mm (0.248 in.)

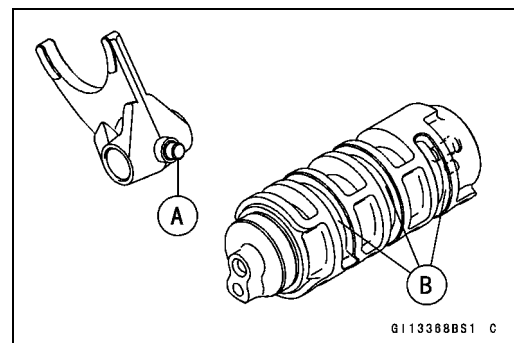

#### **Gear Dog and Gear Dog Hole Damage**

- Visually inspect the gear dogs [A] and gear dog holes [B].
- ★ Replace any damaged gears or gears with excessively worn dogs or dog holes.

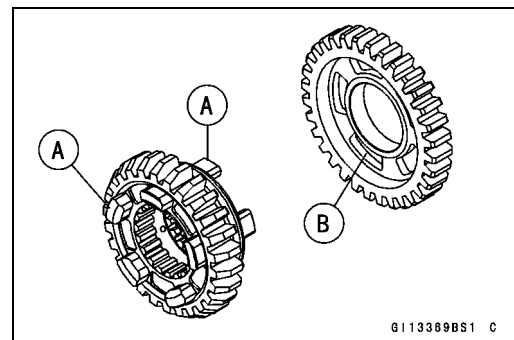

# Wheels/Tires

## Table of Contents

Exploded View .....	10-2
Specifications .....	10-4
Special Tools .....	10-5
Wheels (Rims) .....	10-6
Front Wheel Removal .....	10-6
Front Wheel Installation .....	10-6
Rear Wheel Removal .....	10-7
Rear Wheel Installation .....	10-8
Wheel Inspection .....	10-10
Axle Inspection .....	10-10
Balance Inspection .....	10-11
Balance Adjustment .....	10-11
Balance Weight Removal .....	10-11
Balance Weight Installation .....	10-11
Tires .....	10-13
Air Pressure Inspection/Adjustment .....	10-13
Tire Inspection .....	10-13
Tire Removal .....	10-13
Tire Installation .....	10-13
Tire Repair .....	10-15
Hub Bearing .....	10-16
Hub Bearing Removal .....	10-16
Hub Bearing Installation .....	10-16
Hub Bearing Inspection .....	10-16
Hub Bearing Lubrication .....	10-17



**Exploded View**

<b>No.</b>	<b>Fastener</b>	<b>Torque</b>			<b>Remarks</b>
		<b>N-m</b>	<b>kgf-m</b>	<b>ft-lb</b>	
1	Front Axle Clamp Bolts	20	2.0	15	AL
2	Front Axle Nut	127	13	94	
3	Rear Axle Nut	127	13	94	

AL: Tighten the two clamp bolts alternately two time to ensure even tightening.

G: Apply grease.

HG: Apply high-temperature grease.

R: Replacement Parts

WL: Apply soap and water solution or rubber lubricant.

## 10-4 WHEELS/TIRES

### Specifications

Item	Standard	Service Limit
<b>Wheels (Rims)</b>		
Rim Runout:		
Axial	TIR 0.5 mm (0.02 in.) or less	TIR 1.0 mm (0.04 in.)
Radial	TIR 0.8 mm (0.03 in.) or less	TIR 1.0 mm (0.04 in.)
Axle Runout/100 mm	0.05 mm (0.002 in.) or less	0.2 mm (0.01 in.)
Wheel Balance	10 g (0.35 oz.) or less	— — —
Balance Weights	10 g (0.35 oz.), 20 g (0.71 oz.), 30 g (1.06 oz.)	— — —
Rim Size:		
Front	17 × 3.50	— — —
Rear	17 × 5.50	— — —
<b>Tires</b>		
Air Pressure (when Cold):		
Front	Up to 180 kg (397 lb) load: 250 kPa (2.5 kgf/cm <sup>2</sup> , 36 psi)	— — —
Rear	Up to 180 kg (397 lb) load: 290 kPa (2.9 kgf/cm <sup>2</sup> , 42 psi)	— — —
Tread Depth:		
Front	3.6 mm (0.14 in.)	1 mm (0.04 in.) (AT, CH, DE) 1.6 mm (0.06 in.)
Rear	4.8 mm (0.19 in.)	Up to 130 km/h (80 mph): 2 mm (0.08 in.) Over 130 km/h (80 mph): 3 mm (0.12 in.)
Standard Tires:	Make, Type	Size
Front	BRIDGESTONE, BATTLEAX BT015F RADIAL J	120/70 ZR17 M/C (58 W)
Rear	BRIDGESTONE, BATTLEAX BT015R RADIAL J	180/55 ZR17 M/C (73 W)

### **WARNING**

**Use the same manufacturer's tires on both front and rear wheels.**

Special Tools

Bearing Driver Set:  
57001-1129

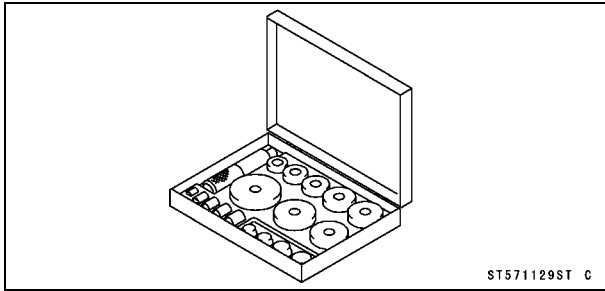

Bearing Remover Shaft,  $\phi 13$ :  
57001-1377

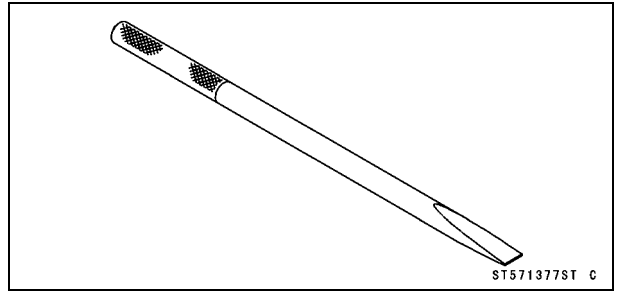

Jack:  
57001-1238

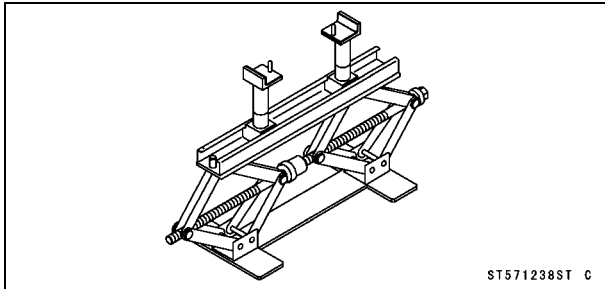

Jack Attachment:  
57001-1608

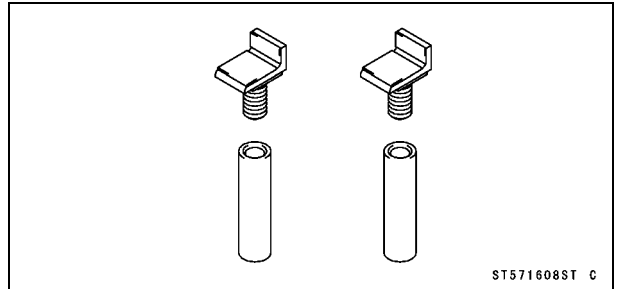

Bearing Remover Head,  $\phi 25 \times \phi 28$ :  
57001-1346

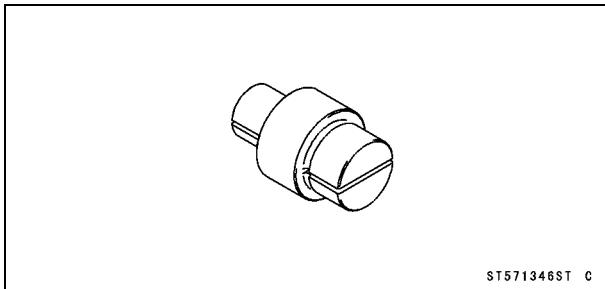

## 10-6 WHEELS/TIRES

### Wheels (Rims)

#### Front Wheel Removal

● Remove:

- Brake Caliper Mounting Bolts [A]
- Front Brake Calipers [B]

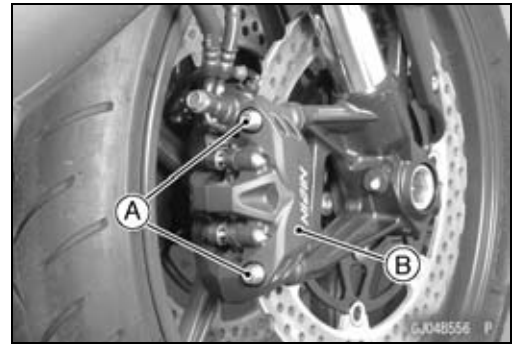

● Loosen:

- Axle Clamp Bolts [A] (Left Side)
- Axle Nut [B]
- Axle Clamp Bolts (Right Side)

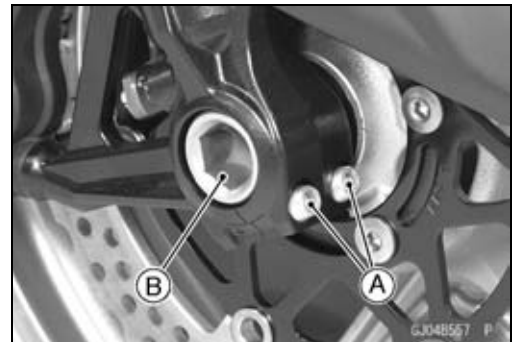

- Remove the lower fairings (see Lower Fairing Removal in the Frame chapter).
- Raise the front wheel off the ground.  
**Special Tools - Jack: 57001-1238**  
**Jack Attachment: 57001-1608**
- Remove the axle nut and pull out the axle to the right and drop the front wheel out of the forks.

#### CAUTION

Do not lay the wheel down on one of the discs. This can damage or warp the disc. Place blocks under the wheel so that the disc does not touch the ground.

#### Front Wheel Installation

##### NOTE

○ The direction of the wheel rotation [A] is shown by an arrow [B] on the wheel spoke.

- Check the wheel rotation mark on the front wheel and install it.

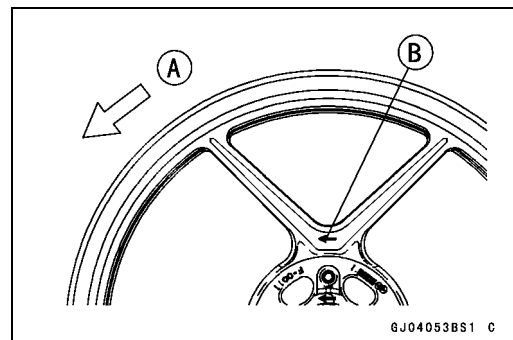



## Wheels (Rims)

- Apply high-temperature grease to the grease seal lip.
- Fit the collars [A] on the both sides of the hub.
- The collars are identical.
- Insert the axle.
- Tighten the axle nut [B].
  - Right Axle Clamp Bolts [C]
  - Left Axle Clamp Bolts [D]
  - Viewed from Rear [E]

**Torque - Front Axle Nut: 127 N·m (13 kgf·m, 94 ft·lb)**

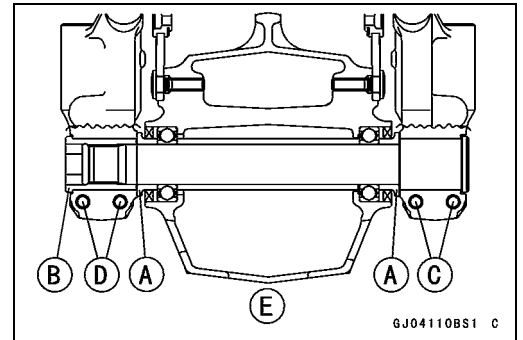

- Before tightening the axle clamp bolts on the right front fork leg, pump the front fork up and down [A] 4 or 5 times to all on the right front fork leg to seat on the front axle.

### NOTE

○ Put a block [B] in front of the front wheel to stop moving.

- Tighten the axle clamp bolts on the right fork leg first. Next, tighten the left axle clamp bolts.

**Torque - Front Axle Clamp Bolts: 20 N·m (2.0 kgf·m, 15 ft·lb)**

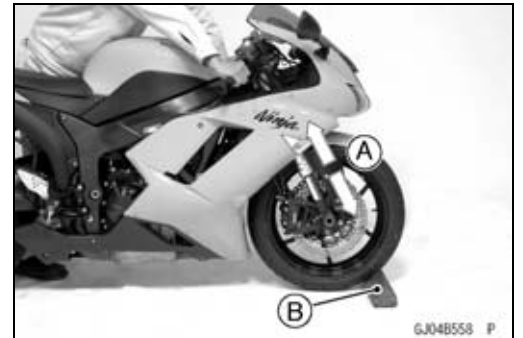

### NOTE

○ Tighten the two clamp bolts alternately two times to ensure even tightening torque.

- Install the front brake calipers (see Caliper Installation in the Brakes chapter).
- Check the front brake effectiveness (see Brake Operation Inspection in the Periodic Maintenance chapter).

## ⚠ WARNING

**Do not attempt to drive the motorcycle until a full brake lever is obtained by pumping the brake lever and the pads are against the disc. The brake will not function on the first application of the lever if this is not done.**

### Rear Wheel Removal

- Raise the rear wheel off the ground with the stand [A].

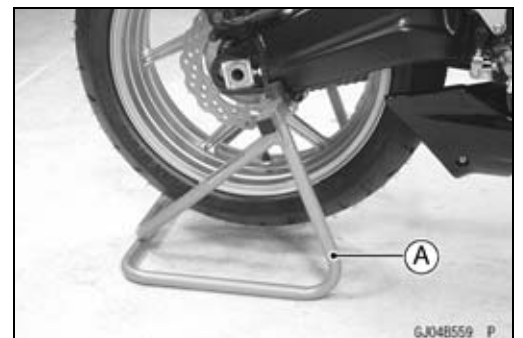

## 10-8 WHEELS/TIRES

### Wheels (Rims)

- Remove:
  - Rear Caliper Mounting Bolts [A]
  - Rear Caliper [B]

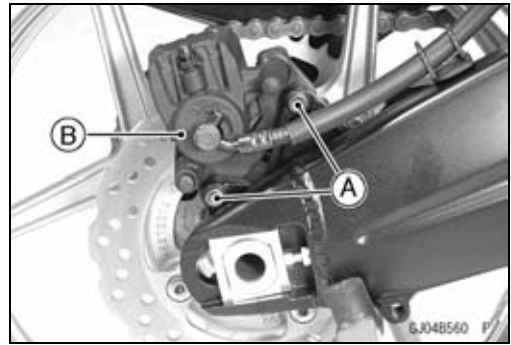

- Remove:
  - Cotter Pin [A]
  - Axle Nut [B]
  - Axle [C] (from Right Side)

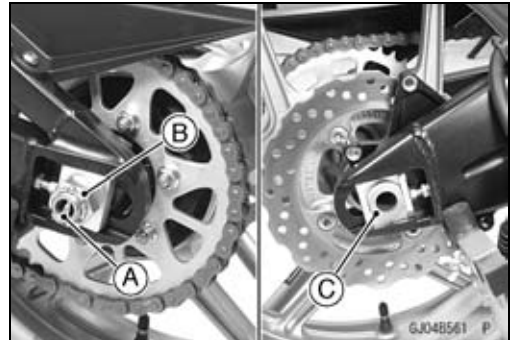

- Remove the drive chain [A] from the rear sprocket toward the left.
- Move the rear wheel back and remove it.



#### CAUTION

**Do not lay the wheel on the ground with the disc facing down. This can damage or warp the disc. Place blocks under the wheel so that the disc does not touch the ground.**

#### **Rear Wheel Installation**

- Fit the collars on the both sides of the hub.
  - Right Side Collar [A] (with Flange)
  - Left Side Collar [B]

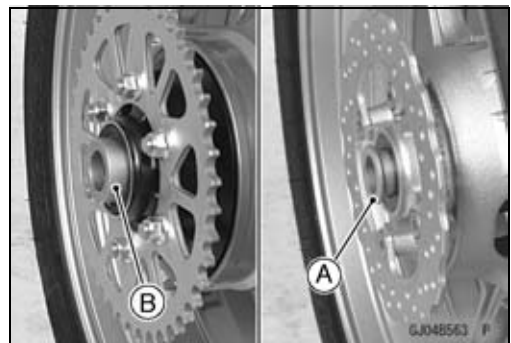

- If the coupling [A] is removed from the rear wheel, apply the grease as shown.

Wheel Flange Portion [B]  
O-ring [C]

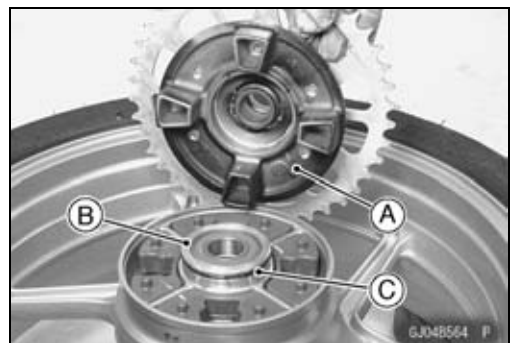

## Wheels (Rims)

- Engage the drive chain with the rear sprocket.
- Install the caliper bracket [A] onto the swingarm stop [B].
- Insert the axle from the right side of the wheel, and tighten the axle nut.

**Torque - Rear Axle Nut: 127 N·m (13 kgf·m, 94 ft·lb)**

- Adjust the drive chain slack after installation (see Drive Chain Slack Inspection in the Periodic Maintenance chapter).

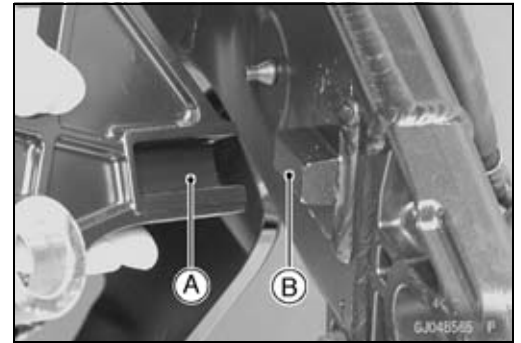

- Insert a new cotter pin [A].

### NOTE

- When inserting the cotter pin, if the slots in the nut do not align with the cotter pin hole in the axle, tighten the nut clockwise [B] up to next alignment.
- It should be within 30°.
- Loosen once and tighten again when the slot goes past the nearest hole.

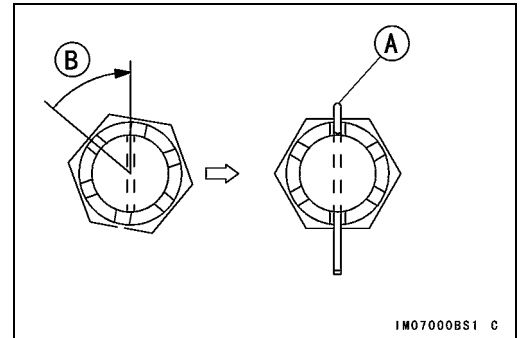

- Bend the cotter pin [A] over the nut.

### ⚠ WARNING

If the rear axle nut is not securely tightened or the cotter pin is not installed, an unsafe riding condition may result.

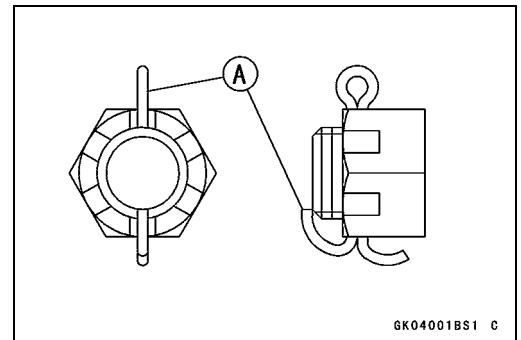

- Install the rear brake caliper (see Caliper Installation in the Brakes chapter).
- Check the rear brake effectiveness (see Brake Operation Inspection in the Periodic Maintenance chapter).

### ⚠ WARNING

Do not attempt to drive the motorcycle until a full brake pedal is obtained by pumping the brake pedal until the pads are against the disc. The brake will not function on the first application of the pedal if this is not done.

# 10-10 WHEELS/TIRES

## Wheels (Rims)

### Wheel Inspection

- Raise the front/rear wheel off the ground.  
**Special Tools - Jack: 57001-1238**  
**Jack Attachment: 57001-1608**
- Spin the wheel lightly, and check for roughness or binding.
- ★ If roughness or binding is found, replace the hub bearings (see Hub Bearing Removal/Installation).
- Inspect the wheel for small cracks, dents, bending, or warp.
- ★ If there is any damage to the wheel, replace the wheel.
- Remove the wheel, and support it with the tire by the axle.
- Measure the rim runout, axial [A] and radial [B], with a dial gauge.
- ★ If rim runout exceeds the service limit, check the hub bearings (see Hub Bearing Inspection).
- ★ If the problem is not due to the bearings, replace the wheel.

### Rim Runout (with tire installed)

#### Standard:

Axial	TIR 0.5 mm (0.02 in.) or less
Radial	TIR 0.8 mm (0.03 in.) or less

#### Service Limit:

Axial	TIR 1.0 mm (0.04 in.)
Radial	TIR 1.0 mm (0.04 in.)

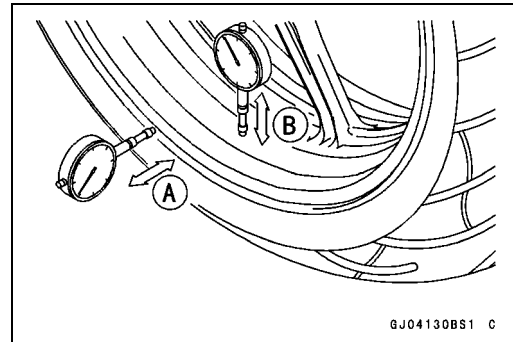

### **⚠ WARNING**

Never attempt to repair a damaged wheel. If there is any damage besides wheel bearings, the wheel must be replaced to insure safe operational condition.

### Axle Inspection

- Remove the front and rear axles (see Front/Rear Wheel Removal).
- Visually inspect the front and rear axle for damages.
- ★ If the axle is damaged or bent, replace it.
- Place the axle in V blocks that are 100 mm (3.94 in.) [A] apart, and set a dial gauge [B] on the axle at a point halfway between the blocks. Turn [C] the axle to measure the runout. The difference between the highest and lowest dial readings is the amount of runout.
- ★ If axle runout exceeds the service limit, replace the axle.

### Axle Runout/100 mm (3.94 in.)

Standard:	0.05 mm (0.002 in.) or less
Service Limit:	0.2 mm (0.01 in.)

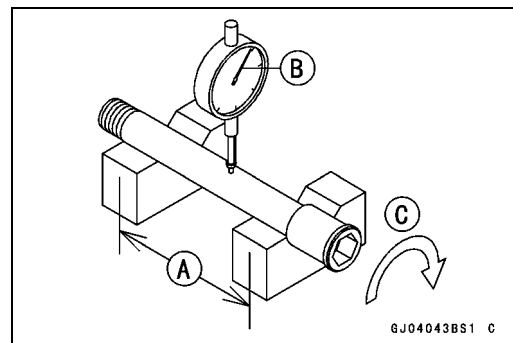

**Wheels (Rims)**

**Balance Inspection**

- Remove the front and rear wheels (see Front/Rear Wheel Removal).
- Support the wheel so that it can be spun freely.
- Spin the wheel lightly, and mark [A] the wheel at the top when the wheel stops.
- Repeat this procedure several times. If the wheel stops of its own accord in various positions, it is well balanced.
- ★ If the wheel always stops in one position, adjust the wheel balance (see Balance Adjustment).

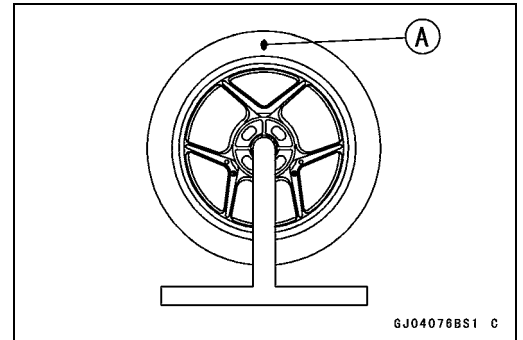

**Balance Adjustment**

- If the wheel always stops in one position, provisionally attach a balance weight [A] on the rim at the marking using adhesive tape.
- Rotate the wheel 1/4 turn [B], and see whether or not the wheel stops in this position. If it does, the correct balance weight is being used.
- ★ If the wheel rotates and the weight goes up, replace the weight with the next heavier size. If the wheel rotates and the weight goes down, replace the weight with the next lighter size. Repeat these steps until the wheel remains at rest after being rotated 1/4 turn.
- Rotate the wheel another 1/4 turn and then another 1/4 turn to see if the wheel is correctly balanced.
- Repeat the entire procedure as many times as necessary to achieve correct wheel balance.
- Permanently install the balance weight.

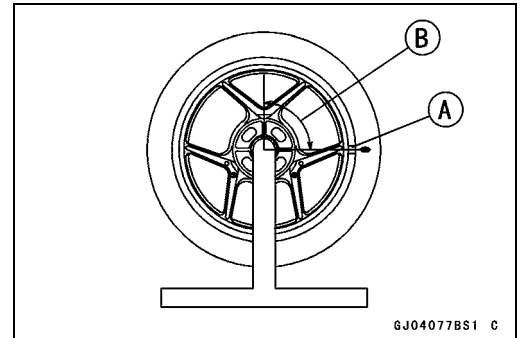

**Balance Weight Removal**

- Insert a regular tip screw drivers [A] [B] between the rib [C] and weight [D] as shown.
- Pry the balance weight with two screwdrivers and remove the balance weight.
- Discard the used balance weight.

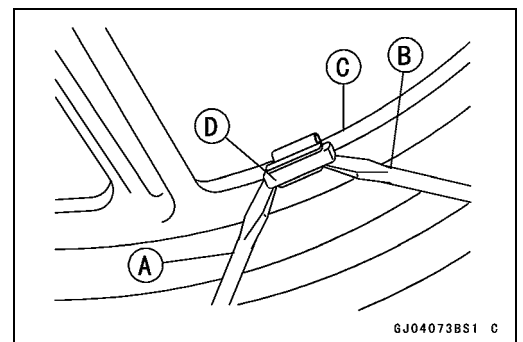

**CAUTION**

**Do not tap the screwdrivers. The rim could be damaged.**

**Balance Weight Installation**

- Check if the weight portion has any play on the blade [A] and clip [B].
- ★ If it does, discard it.

**⚠ WARNING**

**If the balance weight has any play on the rib of the rim, the blade and/or clip have been stretched. Replace the loose balance weight. Do not reuse used balance weight. Unbalanced wheels can create an unsafe riding condition.**

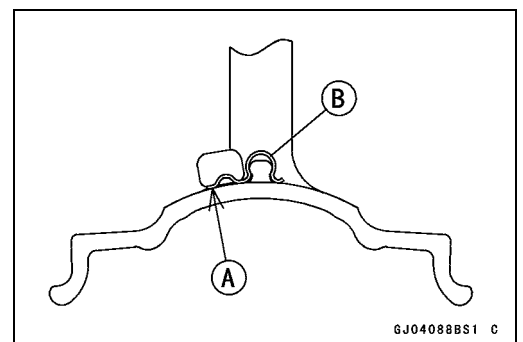

# 10-12 WHEELS/TIRES

## Wheels (Rims)

### Balance Weight

Part Number	Weight
41075-0007	10 g (0.35 oz)
41075-0008	20 g (0.71 oz)
41075-0009	30 g (1.06 oz)

### NOTE

○Balance weights are available from Kawasaki dealers in 10, 20, and 30 gram (0.35 oz, 0.71 oz, and 1.06 oz) sizes. An imbalance of less than 10 grams (0.35 oz) will not usually affect running stability.

○Do not use four or more balance weight (more than 90 gram, 3.2 oz). If the wheel requires an excess balance weight, disassemble the wheel to find the cause.

- Slip the balance weight [A] on to the rib [B], by pushing or lightly hammering [C] the clip [D].

Left Side [E]  
Right Side [F]

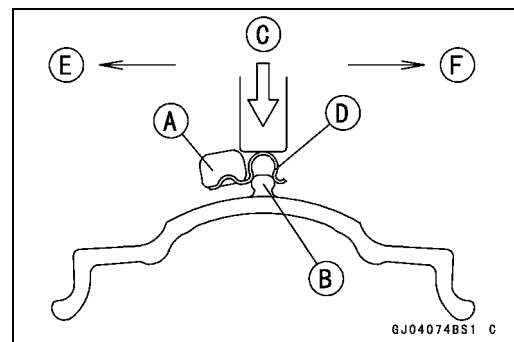

- Be sure to install the balance weight.

○Check that the blade [A] and clip [B] are fully seated on the rim [C] and that the clip is hooked over the rib [D].

Left Side [E]  
Right Side [F]

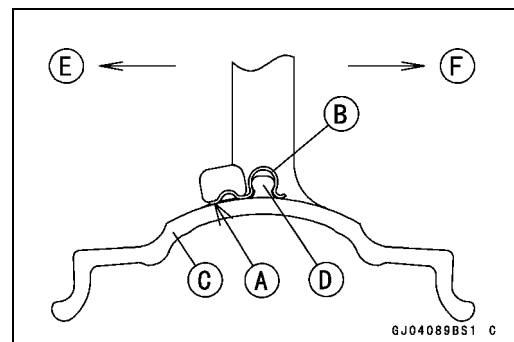

**Tires**

**Air Pressure Inspection/Adjustment**

- Refer to the Air Pressure Inspection in the Periodic Maintenance chapter (see Air Pressure Inspection in the Periodic Maintenance chapter).

**Tire Inspection**

- Refer to the Wheel/Tire Damage Inspection in the Periodic Maintenance chapter (see Wheel/Tires Damage Inspection in the Periodic Maintenance chapter).

**Tire Removal**

- Remove:
  - Wheel (see Front/Rear Wheel Removal)
  - Valve Cap
  - Valve Core (Let out the air)
- To maintain wheel balance, mark the valve stem position on the tire with chalk so that the tire can be reinstalled in the same position.
  - Chalk Mark or Yellow Mark [A]
  - Air Valve [B]
  - Align [C]

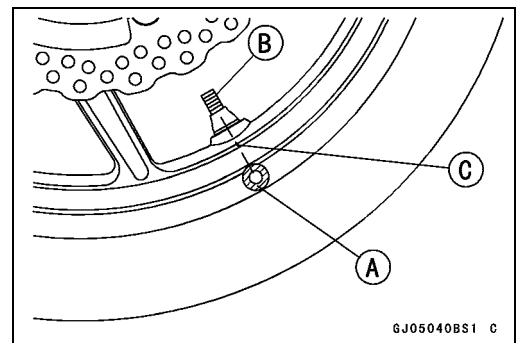

- Lubricate the tire beads and rim flanges on both sides with a soap and water solution or rubber lubricant. This helps the tire beads slip off the rim flanges.

**CAUTION**

**Never lubricate with engine oil or petroleum distillates because they will deteriorate the tire.**

- Remove the tire from the rim using a suitable commercially available tire changer.

**NOTE**

○ *The tires cannot be removed with hand tools because they fit the rims too tightly.*

**Tire Installation**

**⚠ WARNING**

**Use the same manufacturer's on both front and rear wheels.**

- Inspect the rim and tire, and replace them if necessary.
- Clean the sealing surfaces of the rim and tire, and smooth the sealing surfaces of the rim with a fine emery cloth if necessary.
- Remove the air valve and discard it.

**CAUTION**

**Replace the air valve whenever the tire is replaced. Do not reuse the air valve.**

# 10-14 WHEELS/TIRES

## Tires

- Install a new valve in the rim.
- Remove the valve cap, lubricate the stem seal [A] with a soap and water solution or rubber lubricant, and pull [B] the valve stem through the rim from the inside out until it snaps into place.

### CAUTION

**Do not use engine oil or petroleum distillates to lubricate the stem because they will deteriorate the rubber.**

- The air valve is shown in the figure.

- Valve Cap [A]
- Valve Core [B]
- Stem Seal [C]
- Valve Stem [D]
- Valve Seat [E]
- Valve Opened [F]

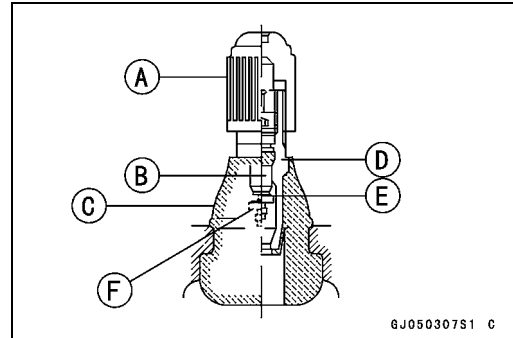
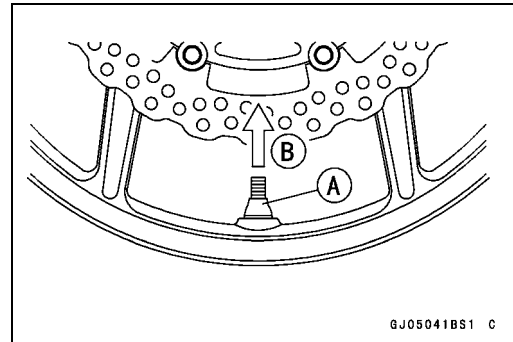

- Check the tire rotation mark on the front and rear tires and install them on the rim accordingly.

- Tire Rotation Mark [A]
- Rotating Direction [B]

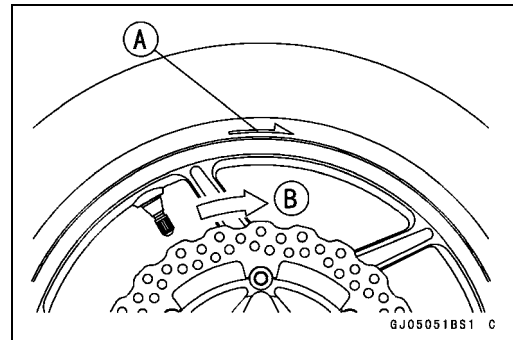

- Position the tire on the rim so that the valve [A] align with the tire balance mark [B] (the chalk mark made during removal, or the yellow paint mark on a new tire).
- Install the tire bead over the rim flange using a suitable commercially available tire changer.
- Lubricate the tire beads and rim flanges with a soap and water solution or rubber lubricant to help seat the tire beads in the sealing surfaces of the rim while inflating the tire.
- Center the rim in the tire beads, and inflate the tire with compressed air until the tire beads seat in the sealing surfaces.

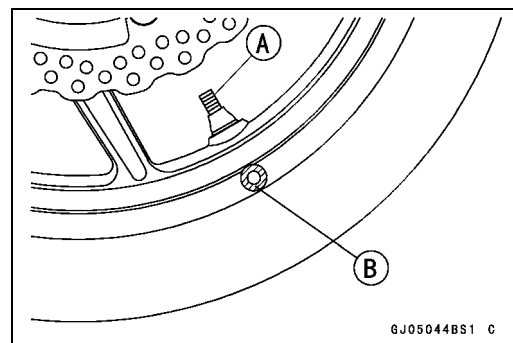

### **⚠ WARNING**

**Be sure to install the valve core whenever inflating the tire, and do not inflate the tire to more than 400 kPa (4.0 kgf/cm<sup>2</sup>, 57 psi). Overinflation can explode the tire with possibility of injury and loss of life.**



## Tires

- Check to see that the rim lines [A] on both sides of the tire sidewalls are parallel with the rim flanges.
- ★ If the rim flanges and tire sidewall rim lines are not parallel, remove the valve core.
- Lubricate the rim flanges and tire beads.
- Install the valve core and inflate the tire again.
- After the tire beads seat in the rim flanges, check for air leakage.
- Inflate the tire slightly above standard inflation.
- Use a soap and water solution or submerge the tire, and check for bubbles that would indicate leakage.
- Adjust the air pressure to the specified pressure (see Air Pressure Inspection in the Periodic Maintenance chapter).
- Install the air valve cap.
- Adjust the wheel balance (see Balance Adjustment in this chapter).

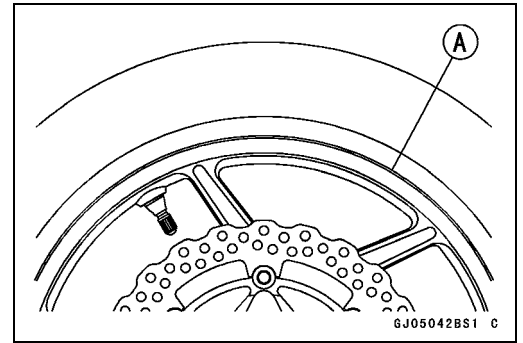

### ***Tire Repair***

Currently two types of repair for tubeless tires have come into wide use. One type is called a temporary (external) repair which can be carried out without removing the tire from the rim, and the other type is called permanent (internal) repair which requires tire removal. It is generally understood that higher running durability is obtained by permanent (internal) repairs than by temporary (external) ones. Also, permanent (internal) repairs have the advantage of permitting a thorough examination for secondary damage not visible from external inspection of the tire. For these reasons, Kawasaki does not recommend temporary (external) repair. Only appropriate permanent (internal) repairs are recommended. Repair methods may vary slightly from make to make. Follow the repair methods indicated by the manufacturer of the repair tools and materials so that safe results can be obtained.

# 10-16 WHEELS/TIRES

## Hub Bearing

### Hub Bearing Removal

- Remove the wheel (see Front/Rear Wheel Removal), and take out the following.
  - Collars
  - Coupling (Out of rear hub)
  - Grease Seals
- Use the bearing remover to remove the hub bearing [A].

#### CAUTION

Do not lay the wheel on the ground with the disc facing down. This can damage or warp the disc. Place blocks under the wheel so that the disc does not touch the ground.

- Special Tools - Bearing Remover Head,  $\phi 25 \times \phi 28$  [C]: 57001-1346  
Bearing Remover Shaft,  $\phi 13$  [B]: 57001-1377

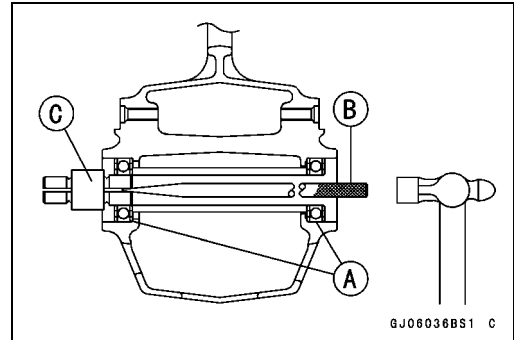

### Hub Bearing Installation

- Before installing the hub bearings, blow any dirt or foreign particles out of the hub with compressed air to prevent contamination of the bearings.
- Replace the bearings with new ones.
- Install the bearings by using the bearing driver set which does not contact the bearing inner race.
- Press in each right the bearing [A] until they are bottomed.

Special Tool - Bearing Driver Set [B]: 57001-1129

- Replace the grease seals with new ones.
- Press in the grease seals [A] so that the seal surface is flush [B] with the end of the hole.
- Apply high-temperature grease to the grease seal lips.

Special Tool - Bearing Driver Set [C]: 57001-1129

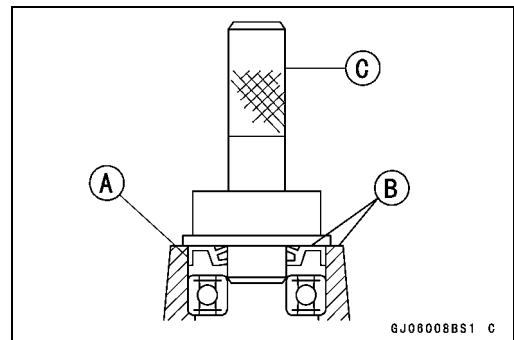
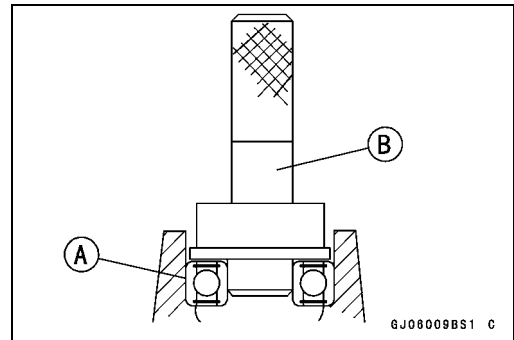

### Hub Bearing Inspection

Since the hub bearings are made to extremely close tolerances, the clearance can not normally be measured.

#### NOTE

○ Do not remove any bearings for inspection. If any bearings are removed, they will need to be replaced with new ones.

- Turn each bearing in the hub back and forth [A] while checking for plays, roughness, or binding.
- ★ If bearing play, roughness, or binding is found, replace the bearing.
- Examine the bearing seal [B] for tears or leakage.
- ★ If the seal is torn or is leaking, replace the bearing.

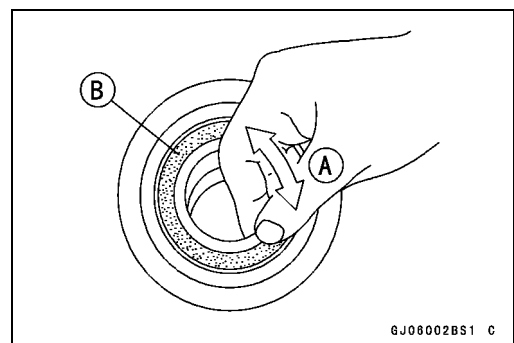

**Hub Bearing**

---

***Hub Bearing Lubrication***

**NOTE**

- *Since the hub bearings are packed with grease and sealed, lubrication is not required.*



# Final Drive

## Table of Contents

Exploded View .....	11-2
Specifications .....	11-4
Special Tools .....	11-5
Drive Chain.....	11-6
Drive Chain Slack Inspection.....	11-6
Drive Chain Slack Adjustment .....	11-6
Wheel Alignment Inspection/Adjustment .....	11-6
Drive Chain Wear Inspection .....	11-6
Drive Chain Lubrication.....	11-6
Drive Chain Removal.....	11-6
Drive Chain Installation.....	11-7
Sprocket, Coupling .....	11-10
Engine Sprocket Removal .....	11-10
Engine Sprocket Installation .....	11-10
Rear Sprocket Removal.....	11-11
Rear Sprocket Installation.....	11-11
Coupling Installation.....	11-12
Coupling Bearing Removal .....	11-12
Coupling Bearing Installation .....	11-12
Coupling Bearing Inspection.....	11-13
Coupling Bearing Lubrication.....	11-13
Coupling Damper Inspection.....	11-13
Sprocket Wear Inspection.....	11-13
Rear Sprocket Warp Inspection .....	11-14

# 11-2 FINAL DRIVE

## Exploded View

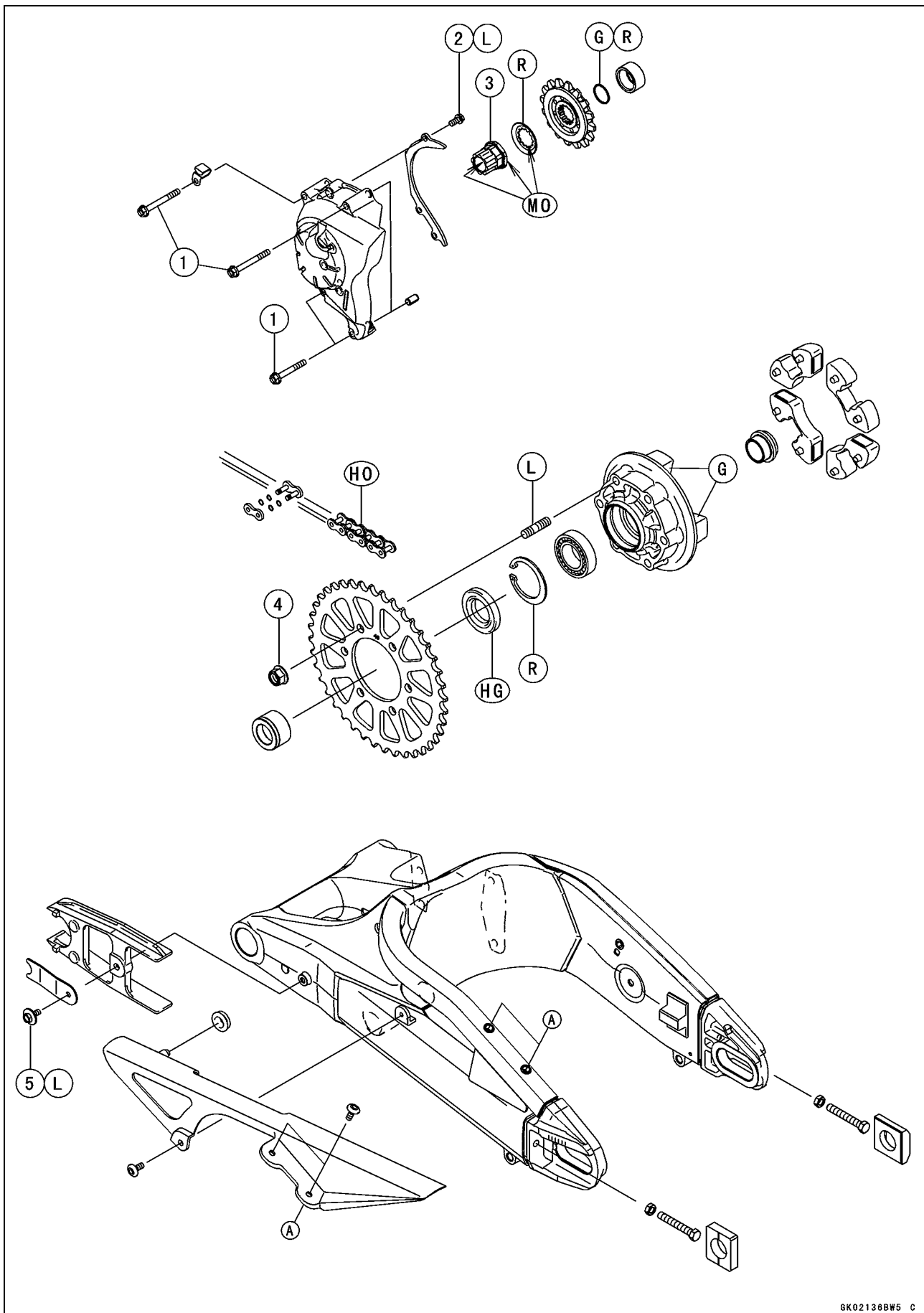

## Exploded View

No.	Fastener	Torque			Remarks
		N·m	kgf·m	ft·lb	
1	Engine Sprocket Cover Bolts	9.8	1.0	87 in·lb	
2	Chain Guide Bolts (Front)	9.8	1.0	87 in·lb	L
3	Engine Sprocket Nut	125	13	92	MO
4	Rear Sprocket Nuts	59	6.0	43	
5	Chain Guide Bolt (Rear)	4.9	0.50	43 in·lb	L

G: Apply grease.

HG: Apply high-temperature grease.

HO: Apply heavy oil.

L: Apply a non-permanent locking agent.

MO: Apply molybdenum disulfide oil solution.

(mixture of the engine oil and molybdenum disulfide grease in a weight ratio 10 : 1)

R: Replacement Parts

## 11-4 FINAL DRIVE

### Specifications

Item	Standard	Service Limit
<b>Drive Chain</b>		
Drive Chain Slack	30 ~ 40 mm (1.2 ~ 1.6 in.)	---
Drive Chain Wear (20-link Length)	317.5 ~ 318.2 mm (12.50 ~ 12.53 in.)	323 mm (12.7 in.)
Standard Chain:		
Make	ENUMA	---
Type	EK520MVXL1	---
Link	112 links	---
<b>Sprockets</b>		
Rear Sprocket Warp	0.4 mm (0.016 in.) or less	0.5 mm (0.02 in.)



**Special Tools**

---

**Inside Circlip Pliers:**  
**57001-143**

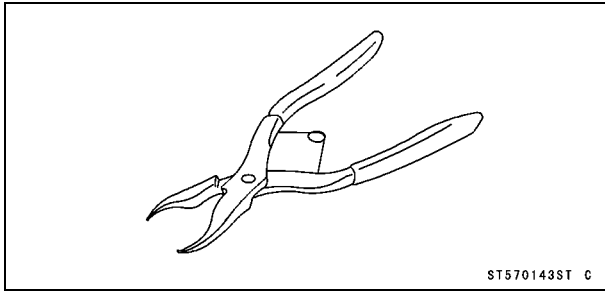

**Bearing Driver Set:**  
**57001-1129**

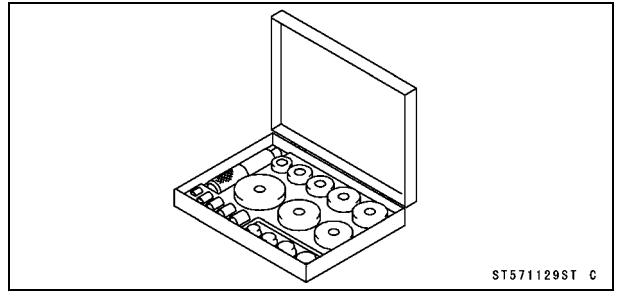

## 11-6 FINAL DRIVE

### Drive Chain

#### **Drive Chain Slack Inspection**

- Refer to the Drive Chain Slack Inspection in the Periodic Maintenance chapter (see Drive Chain Slack Inspection in the Periodic Maintenance chapter).

#### **Drive Chain Slack Adjustment**

- Refer to the Drive Chain Slack Adjustment in the Periodic Maintenance chapter (see Drive Chain Slack Adjustment in the Periodic Maintenance chapter).

#### **Wheel Alignment Inspection/Adjustment**

- Refer to the Wheel Alignment Inspection in the Periodic Maintenance chapter (see Wheel Alignment Inspection in the Periodic Maintenance chapter).

#### **Drive Chain Wear Inspection**

- Refer to the Drive Chain Wear Inspection in the Periodic Maintenance chapter (see Drive Chain Wear Inspection in the Periodic Maintenance chapter).

#### **Drive Chain Lubrication**

- Refer to the Drive Chain Lubrication Condition Inspection in the Periodic Maintenance chapter (see Drive Chain Lubrication Condition Inspection in the Periodic Maintenance chapter).

#### **Drive Chain Removal**

##### **NOTE**

○ Since the drive chain is installed through the swingarm, the chain cannot be removed other than by cutting it. Prepare the new link pin, link plate, grease seals, and tools for rejoining the chain.

- Using a suitable tool, cut the drive chain by removing the link pins.

**Recommended Tool: EK Joint Tool #50**

##### **CAUTION**

**Read the Tool Manual before removing.**

- Body [A]
- Handlebar [B]
- Cutting and Riveting Pin [C]
- For Cutting [D]
- For Riveting [E]
- Plate Holder (a) [F]
- Plate Holder (b) [G]
- Gauge [H]

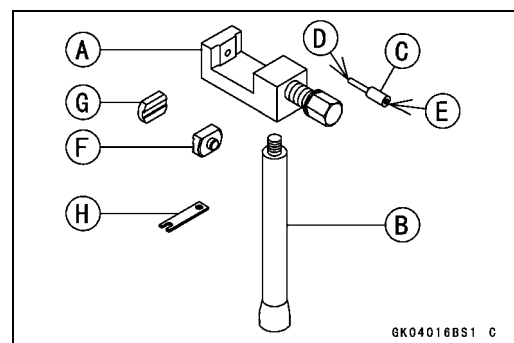

**Drive Chain**

- Grind [A] the pin head to make it flat.
- Set the cutting and riveting pin [B] as shown.

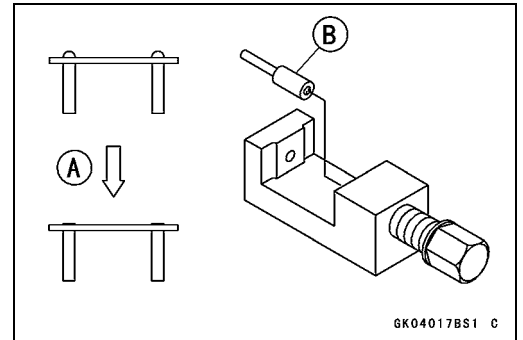

- Screw the pin holder until it touches chain pin.
- Be sure that the cutting pin hits center of chain pin.

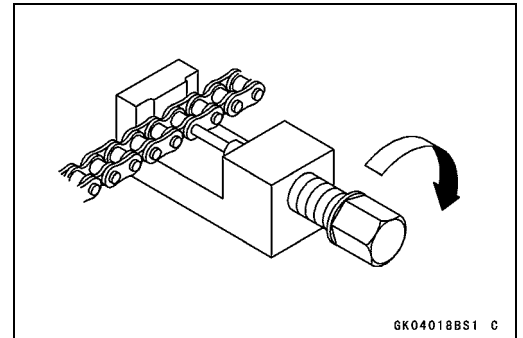

- Screw the handlebar [A] into body.
- Turn the pin holder with wrench [B] clockwise to extract chain pin.

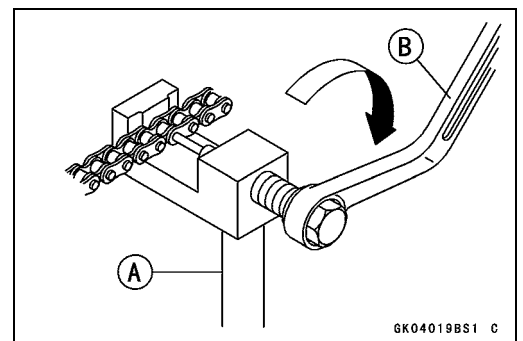

**Drive Chain Installation**

- Engage the new drive chain to the old drive chain and pull the end of the old drive chain until they are changing the position.
- Remove the old drive chain from the new drive chain.
- Apply grease to the link pins [A] and grease seals [B] [C].
- Engage the drive chain on the rear sprocket through the swingarm.
- Insert the link pins in the drive chain ends.
- Install the grease seals [C].
- Install the link plate so that the mark [D] faces out.
- Push the link plate by hand or plier to fix it.
- In case of grease seal chain, be sure to set the grease seals correctly.

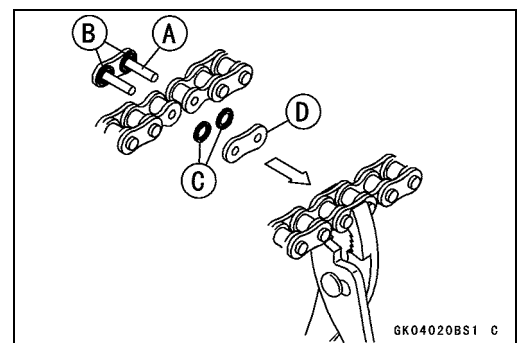

## 11-8 FINAL DRIVE

### Drive Chain

- Set the plate holder (a) [A] and plate holder (b) [B] on the body.

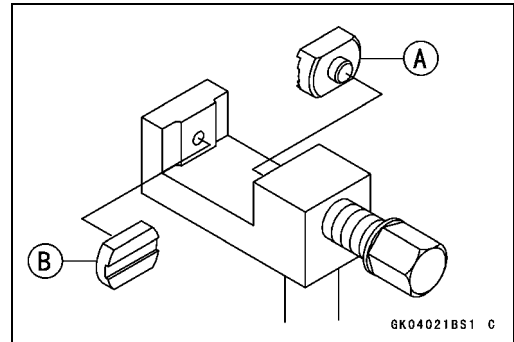

- Fit the plate holder (a) to link plate.
- Turn the pin holder by hand until plate holder (b) touches the other link plate.

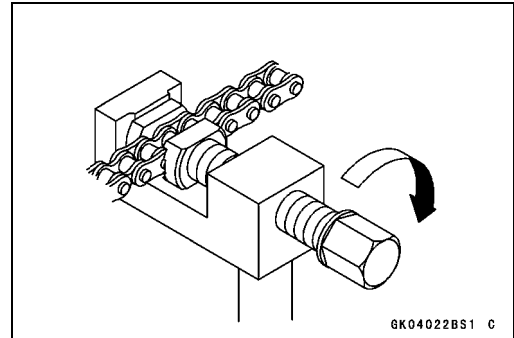

- Turn the pin holder by wrench clockwise until two pins of link come into groove of plate holder (a).
- Take off the plate holder (a).

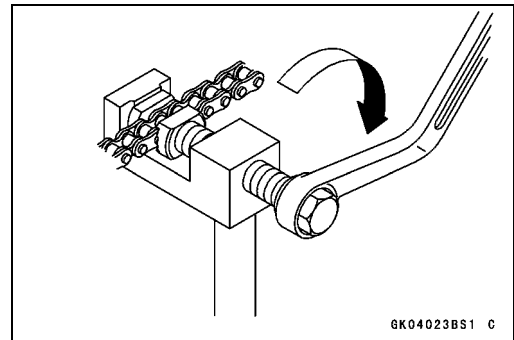

- Set the plate holder (b) [A] and cutting and riveting pin [B] as shown.

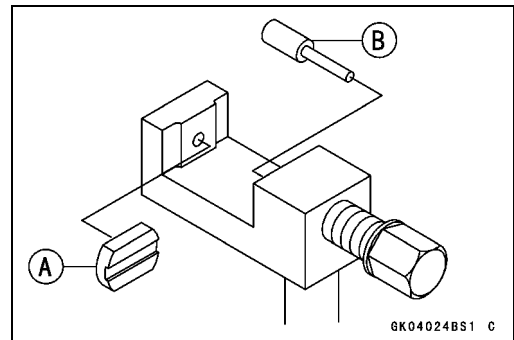

- Turn the pin holder until riveting pin touches link pin.

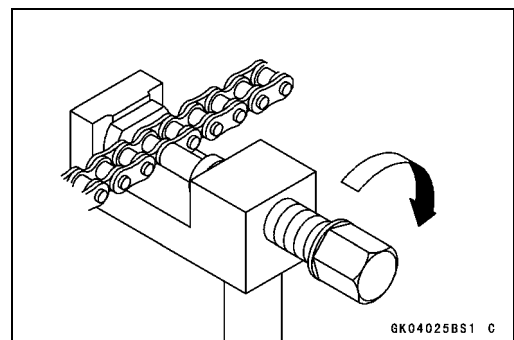

## Drive Chain

- Turn the wrench clockwise until tip of riveting pin hits of link pin.
- Rivet it.
- Same work for the other link pin.

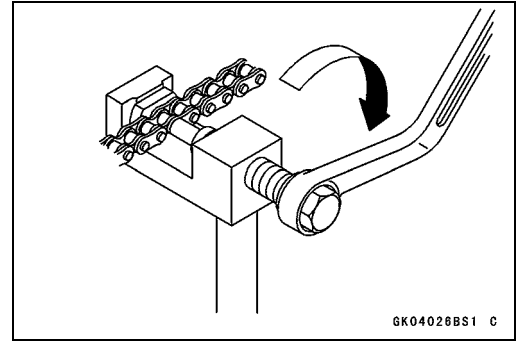

- After staking, check the staked area of the link pin for cracks.
- Measure the outside diameter [A] of the link pin and link plates width [B].

### Link Pin Outside Diameter

Standard: 5.7 ~ 6.0 mm (0.22 ~ 0.24 in.)

### Link Plates Outside Width

Standard: 17.25 ~ 17.45 mm (0.679 ~ 0.687 in.)

- ★ If the reading exceeds the specified length, cut and rejoin the chain again.
- Check:
  - Movement of the Rollers
- Adjust the drive chain slack after installing the chain (see Drive Chain Slack Adjustment in the Periodic Maintenance chapter).

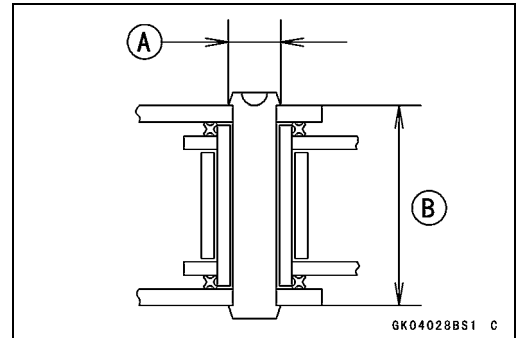

## 11-10 FINAL DRIVE

### Sprocket, Coupling

#### Engine Sprocket Removal

- Remove:
  - Speed Sensor Bolt [A]
  - Speed Sensor [B]
  - Engine Sprocket Cover Bolts [C]
  - Engine Sprocket Cover [D]

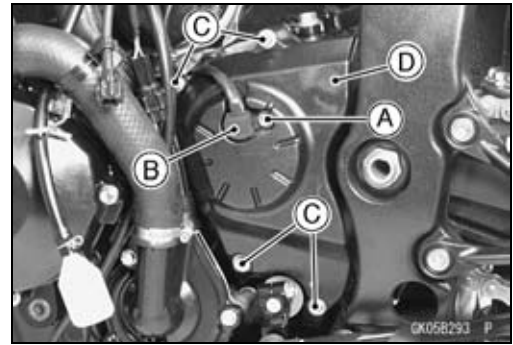

- Flatten out the bended washer [A].
- Remove the engine sprocket nut [B] and washer.

#### NOTE

○ When loosening the engine sprocket nut, hold the rear brake on.

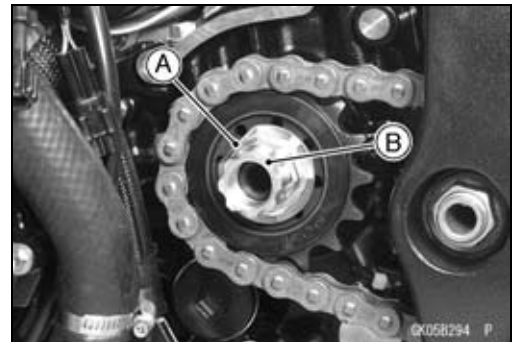

- Raise the rear wheel off the ground.
- Remove the axle cotter pin, and loosen the rear axle nut.
- Loosen the both chain adjuster locknut to loosen the drive chain.
- Remove the drive chain from the rear sprocket toward the right.
- Pull the engine sprocket [A] with drive chain [B] off the output shaft [C].
- Disengage the drive chain from the engine sprocket.

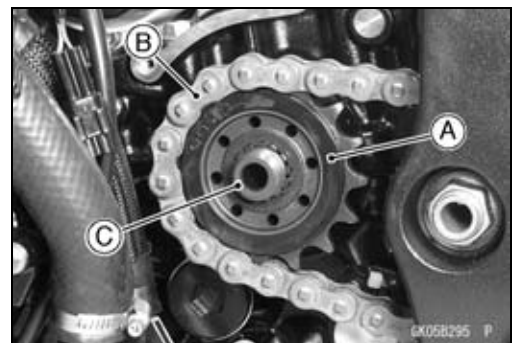

#### Engine Sprocket Installation

- Replace the sprocket washer and axle cotter pin.
- Install the engine sprocket onto the shaft so that the mark side [A] faces outwards.
- Apply molybdenum disulfide oil solution to the threads of the output shaft and the seating surface of the engine sprocket nut.
- After torquing the engine sprocket nut, bend the one side [B] of the washer [C] over the nut.

#### NOTE

○ Tighten the nut while applying the rear brake.

**Torque - Engine Sprocket Nut: 125 N·m (13 kgf·m, 92 ft·lb)**

- Adjust the drive chain slack after installing the sprocket (see Drive Chain Slack Adjustment in the Periodic Maintenance chapter).

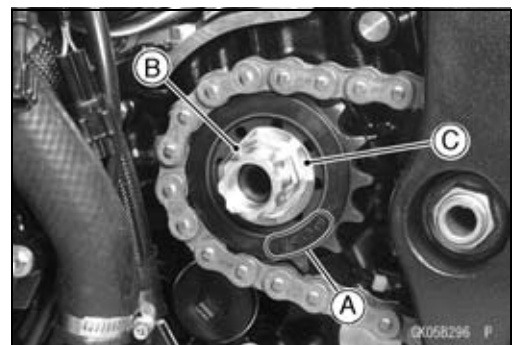

## Sprocket, Coupling

- Make sure that dowel pins [A] are in place.
- Install the engine sprocket cover.
- Install the clamp [B] as shown, and tighten the cover bolts.
  - Torque - Engine Sprocket Cover Bolts: 6.9 N·m (0.70 kgf·m, 61 in·lb)**
- Install the speed sensor (see Speed Sensor Installation in the Electrical System chapter).
- Bend the end of axle cotter pin surely after tightening the axle nut.

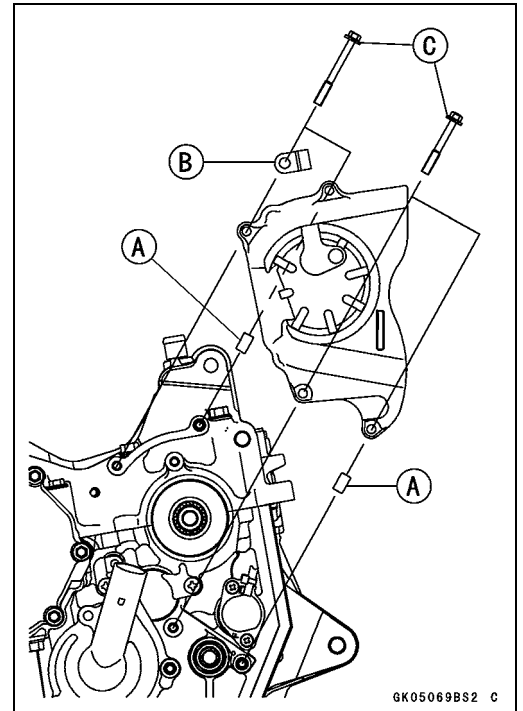

### Rear Sprocket Removal

- Remove the rear wheel (see Rear Wheel Removal in the Wheels/Tires chapter).

#### CAUTION

Do not lay the wheel on the ground with the disc facing down. This can damage or warp the disc. Place blocks under the wheel so that the disc does not touch the ground.

- Remove the rear sprocket nuts [A].
- Remove the rear sprocket [B].

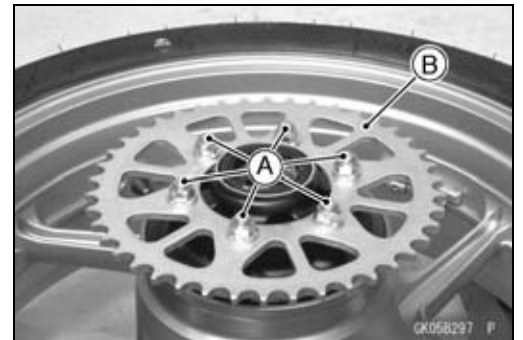

### Rear Sprocket Installation

- Install the sprocket facing the tooth number marking [A] outward.
- Tighten the rear sprocket nuts.

**Torque - Rear Sprocket Nuts: 59 N·m (6.0 kgf·m, 43 ft·lb)**

- Install the rear wheel (see Rear Wheel Installation in the Wheels/Tires chapter).



# 11-12 FINAL DRIVE

## Sprocket, Coupling

### Coupling Installation

- Grease the following and install the coupling.
  - Coupling Grease Seal Lips [A]
  - Coupling Internal Surface [B]

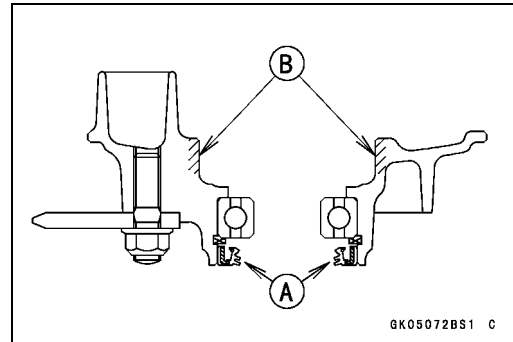

- Apply grease to the O-ring [A].
- Install the collar [B]

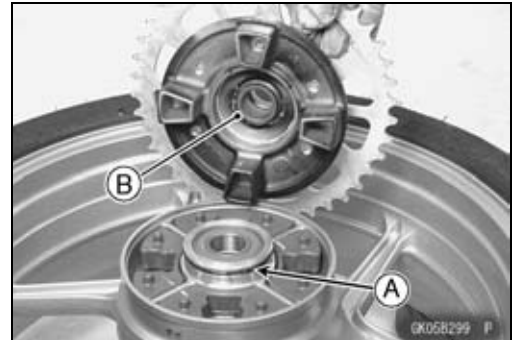

### Coupling Bearing Removal

- Remove:
  - Coupling
  - Grease Seal
  - Circlip [A] (discard)
- Special Tool - Inside Circlip Pliers [B]: 57001-143**

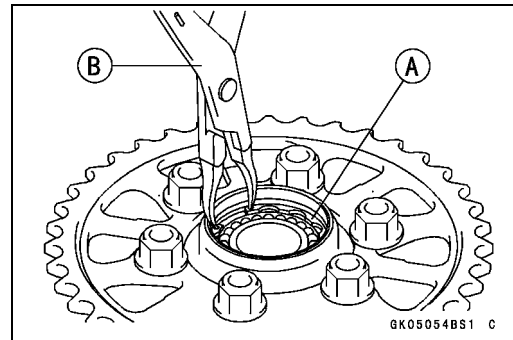

- Remove the bearing [A] by tapping from the wheel side.
- Special Tool - Bearing Driver Set [B]: 57001-1129**

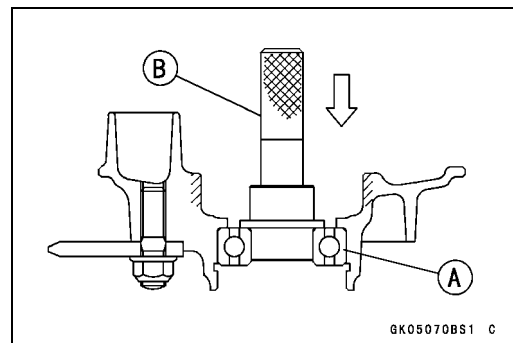

### Coupling Bearing Installation

- Replace the bearing with a new one.

#### NOTE

○ Install the bearing so that the marked side faces out.

- Press in the bearing [A] until it is bottomed.
- Special Tool - Bearing Driver Set [B]: 57001-1129**
- Replace the circlip with a new one.
- Special Tool - Inside Circlip Pliers: 57001-143**

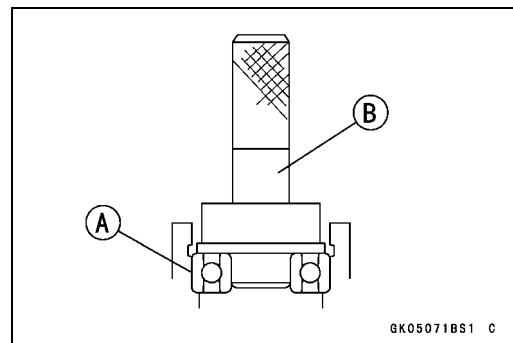



## Sprocket, Coupling

- Replace the grease seal with a new one.
- Press in the grease seal so that the seal surface is flush with the end of the hole.
- Apply high-temperature grease to the grease seal lips.

**Special Tool - Bearing Driver Set: 57001-1129**

### Coupling Bearing Inspection

Since the coupling bearing is made to extremely close tolerances, the clearance can not normally be measured.

#### NOTE

○ It is not necessary to remove the coupling bearing for inspection. If the bearing is removed, it will need to be replaced with a new one.

- Spin [A] the bearing by hand to check its condition.
- ★ If it is noisy, does not spin smoothly, or has any rough spots, it must be replaced.

### Coupling Bearing Lubrication

- Pack the bearing with good quality bearing grease [A]. Turn the bearing around by hand a few times to make sure the grease is distributed uniformly inside the bearing.

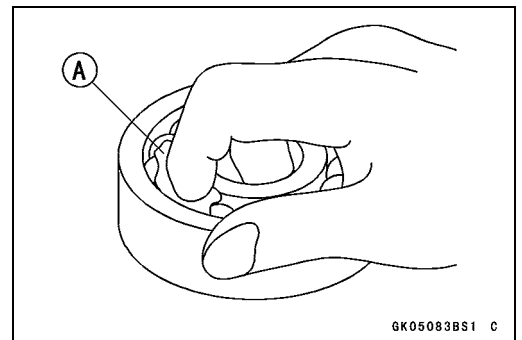
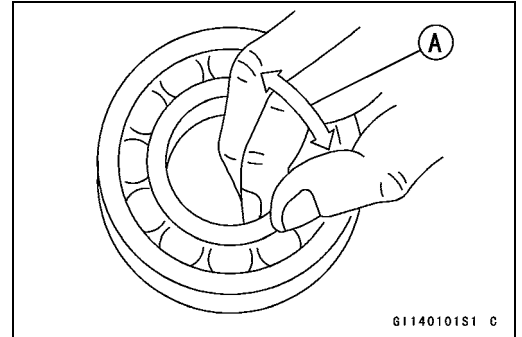

### Coupling Damper Inspection

- Remove the rear wheel coupling, and inspect the rubber dampers [A].
- Replace the damper if it appears damaged or deteriorated.

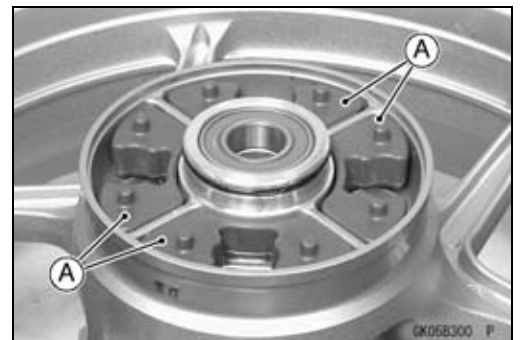

### Sprocket Wear Inspection

- Visually inspect the engine and rear sprocket teeth for wear and damage.
- ★ If the teeth are worn as illustrated, replace the sprocket, and inspect the drive chain wear (see Drive Chain Wear Inspection in the Periodic Maintenance chapter).
  - Worn Tooth (Engine Sprocket) [A]
  - Worn Tooth (Rear Sprocket) [B]
  - Direction of Rotation [C]

#### NOTE

○ If a sprocket requires replacement, the chain is probably worn also.  
When replacing a sprocket, inspect the chain.

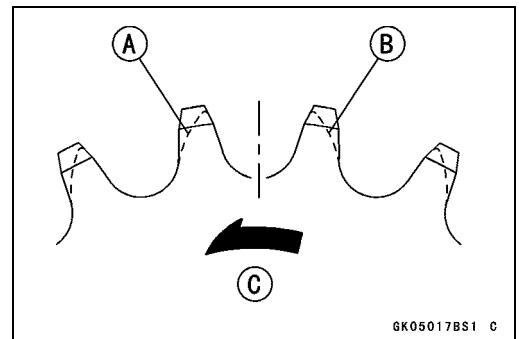

## 11-14 FINAL DRIVE

### Sprocket, Coupling

#### ***Rear Sprocket Warp Inspection***

- Raise the rear wheel off the ground so that it will turn freely.
- Set a dial gauge [A] against the rear sprocket [B] near the teeth as shown, and rotate [C] the rear wheel to measure the sprocket runout (warp). The difference between the highest and lowest dial gauge readings is the amount of runout (warp).
- ★ If the runout exceeds the service limit, replace the rear sprocket.

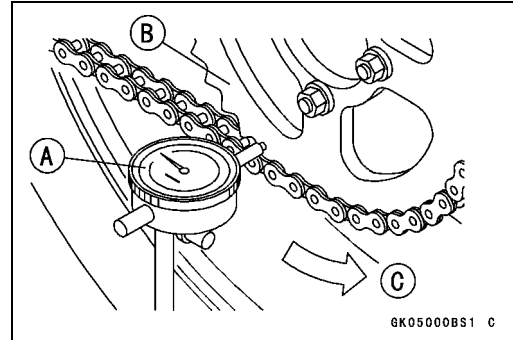

#### **Rear Sprocket Warp**

**Standard:** 0.4 mm (0.016 in.) or less

**Service Limit:** 0.5 mm (0.02 in.)

# Brakes

## Table of Contents

Exploded View .....	12-2
Specifications .....	12-6
Special Tools .....	12-7
Brake Lever, Brake Pedal.....	12-8
Brake Lever Position Adjustment.....	12-8
Brake Pedal Position Inspection .....	12-8
Brake Pedal Position Adjustment .....	12-8
Brake Pedal Removal .....	12-8
Brake Pedal Installation .....	12-9
Calipers .....	12-10
Front Caliper Removal.....	12-10
Rear Caliper Removal.....	12-10
Caliper Installation .....	12-10
Front Caliper Disassembly.....	12-11
Front Caliper Assembly.....	12-11
Rear Caliper Disassembly .....	12-11
Rear Caliper Assembly .....	12-11
Caliper Fluid Seal Damage .....	12-11
Rear Caliper Dust Boot and Friction Boot Damage .....	12-12
Caliper Piston and Cylinder Damage.....	12-12
Rear Caliper Holder Shaft Wear .....	12-12
Brake Pads .....	12-13
Front Brake Pad Removal.....	12-13
Front Brake Pad Installation.....	12-13
Rear Brake Pad Removal .....	12-13
Rear Brake Pad Installation .....	12-14
Brake Pad Wear Inspection .....	12-14
Master Cylinder .....	12-15
Front Master Cylinder Removal .....	12-15
Front Master Cylinder Installation .....	12-15
Rear Master Cylinder Removal.....	12-16
Rear Master Cylinder Installation.....	12-16
Front Master Cylinder Disassembly .....	12-16
Rear Master Cylinder Disassembly.....	12-16
Master Cylinder Inspection (Visual Inspection).....	12-16
Master Cylinder Assembly .....	12-17
Brake Disc .....	12-18
Brake Disc Removal .....	12-18
Brake Disc Installation .....	12-18
Brake Disc Wear .....	12-18
Brake Disc Warp .....	12-18
Brake Fluid .....	12-19
Brake Fluid Level Inspection.....	12-19
Brake Fluid Change .....	12-19
Brake Line Bleeding.....	12-19
Brake Hose.....	12-23
Brake Hose Removal/Installation.....	12-23
Brake Hose Inspection.....	12-23

# 12-2 BRAKES

## Exploded View

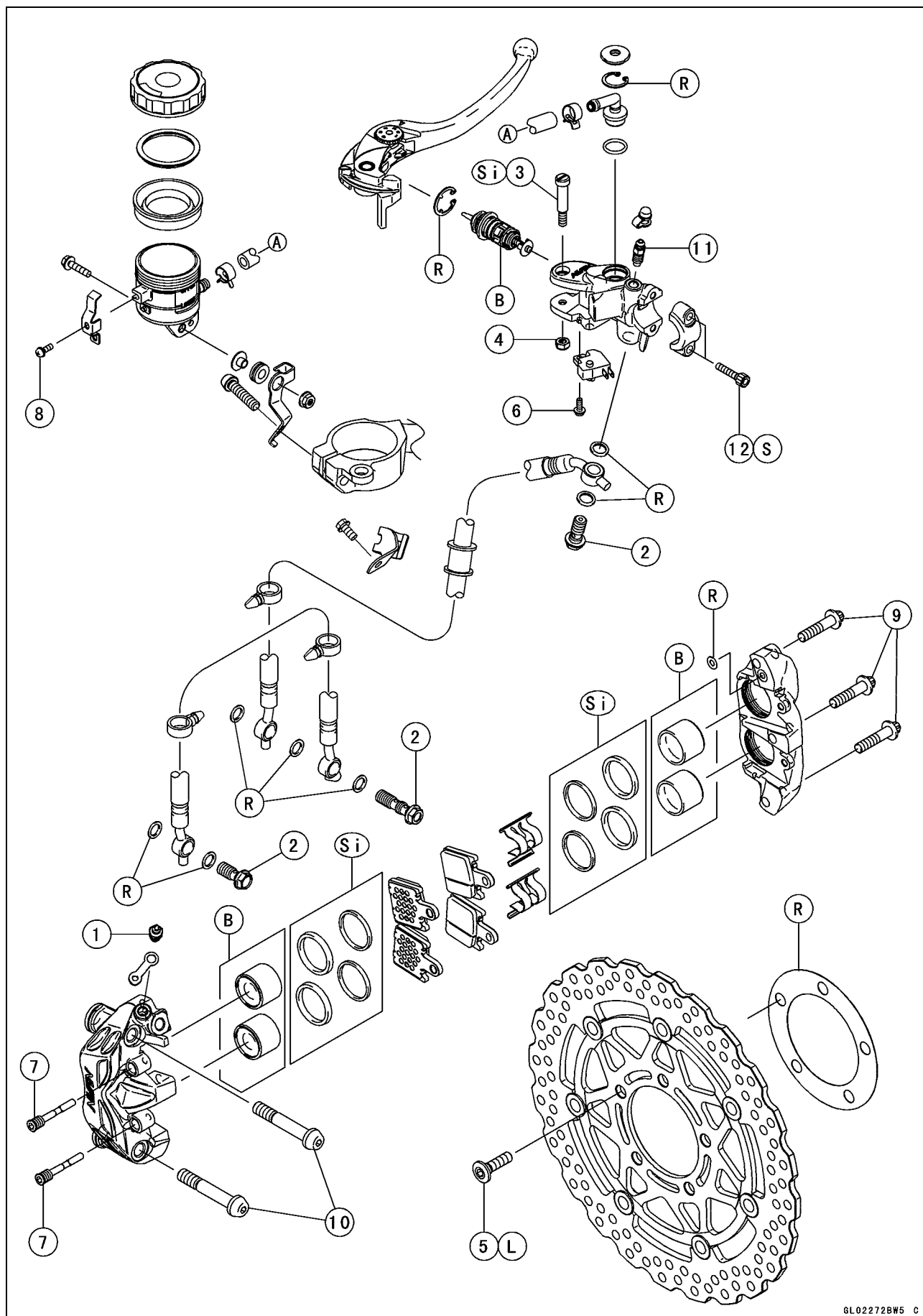

## Exploded View

No.	Fastener	Torque			Remarks
		N·m	kgf·m	ft·lb	
1	Bleed Valves	7.8	0.80	69 in·lb	
2	Brake Hose Banjo Bolts	25	2.5	18	
3	Brake Lever Pivot Bolt	1.0	0.10	9 in·lb	Si
4	Brake Lever Pivot Bolt Locknut	5.9	0.60	52 in·lb	
5	Front Brake Disc Mounting Bolts	27	2.8	20	L
6	Front Brake Light Switch Screw	1.2	0.12	10 in·lb	
7	Front Brake Pad Pins	17	1.7	12	
8	Front Brake Reservoir Cap Stopper Screw	1.2	0.12	10 in·lb	
9	Front Caliper Assembly Bolts	27	2.8	20	
10	Front Caliper Mounting Bolts	34	3.5	25	
11	Front Master Cylinder Bleed Valve	5.9	0.60	52 in·lb	
12	Front Master Cylinder Clamp Bolts	11	1.1	97 in·lb	S

B: Apply brake fluid.

L: Apply a non-permanent locking agent.

R: Replacement Parts

S: Follow the specified tightening sequence.

Si: Apply silicone grease.

# 12-4 BRAKES

## Exploded View

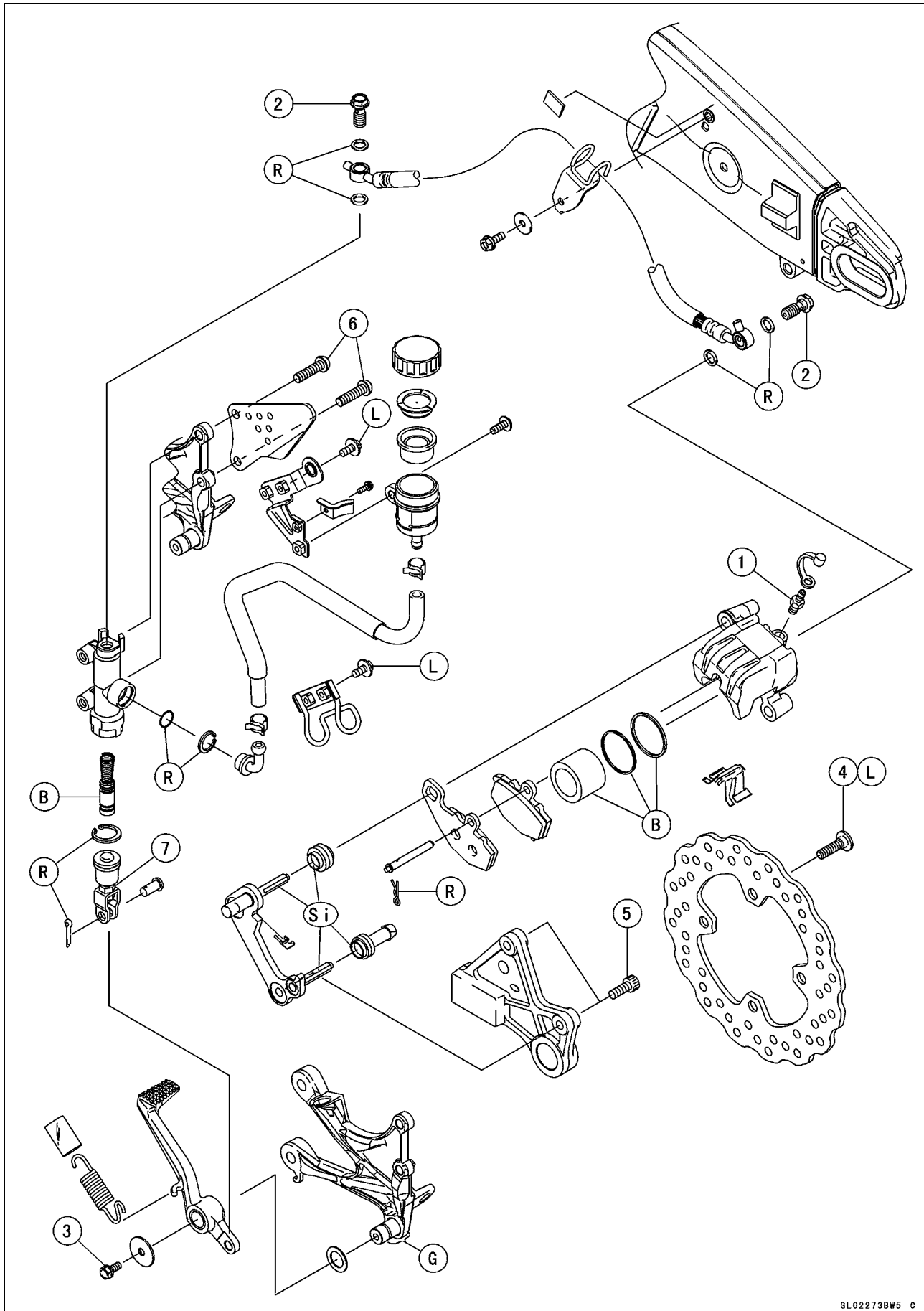

## Exploded View

No.	Fastener	Torque			Remarks
		N·m	kgf·m	ft·lb	
1	Bleed Valve	7.8	0.80	69 in·lb	
2	Brake Hose Banjo Bolts	25	2.5	18	
3	Brake Pedal Bolt	8.8	0.90	78 in·lb	
4	Rear Brake Disc Mounting Bolts	27	2.8	20	L
5	Rear Caliper Mounting Bolts	25	2.5	18	
6	Rear Master Cylinder Mounting Bolts	25	2.5	18	
7	Rear Master Cylinder Push Rod Locknut	18	1.8	13	

B: Apply brake fluid.

G: Apply grease.

L: Apply a non-permanent locking agent.

R: Replacement Parts

Si: Apply silicone grease.

## 12-6 BRAKES

### Specifications

Item	Standard	Service Limit
<b>Brake Lever, Brake Pedal</b>		
Brake Lever Position	6-way adjustable (to suit rider)	---
Brake Lever Free Play	Non-adjustable	---
Pedal Free Play	Non-adjustable	---
Pedal Position	About 78 mm (3.1 in.) below footpeg top	---
<b>Brake Fluid</b>		
Grade	DOT4	---
<b>Brake Pads</b>		
Pad Lining Thickness:		
Front	4 mm (0.16 in.)	1 mm (0.04 in.)
Rear	5 mm (0.20 in.)	1 mm (0.04 in.)
<b>Brake Discs</b>		
Thickness:		
Front	5.8 ~ 6.2 mm (0.23 ~ 0.24 in.)	5.5 mm (0.22 in.)
Rear	4.8 ~ 5.2 mm (0.19 ~ 0.20 in.)	4.5 mm (0.18 in.)
Runout	TIR 0.15 mm (0.006 in.) or less	TIR 0.3 mm (0.01 in.)



**Special Tools**

**Inside Circlip Pliers:**  
**57001-143**

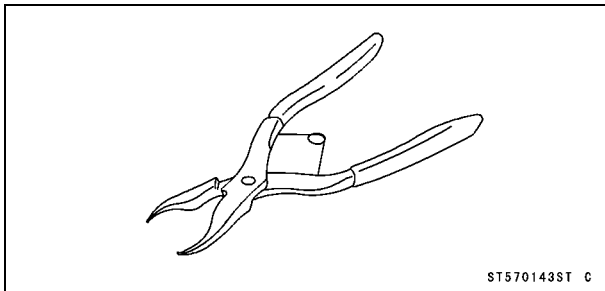

**Jack Attachment:**  
**57001-1608**

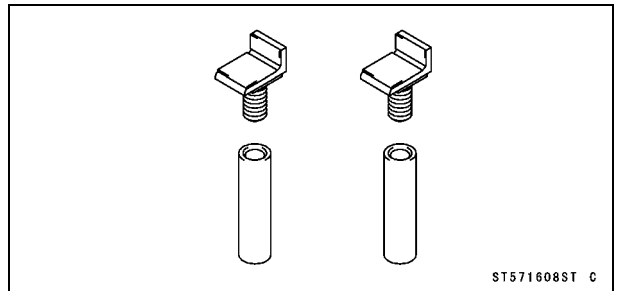

**Jack:**  
**57001-1238**

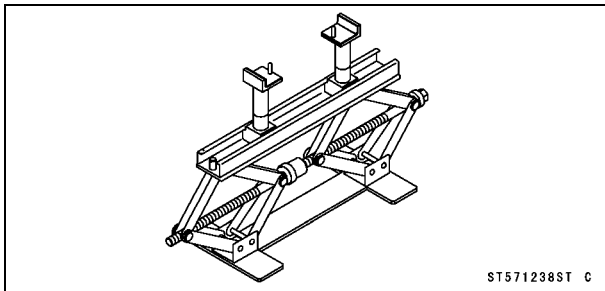

## 12-8 BRAKES

### Brake Lever, Brake Pedal

#### **Brake Lever Position Adjustment**

The brake lever adjuster has 6 positions so that the brake lever position can be adjusted to suit the operator's hand.

- Push the lever forward and turn the adjuster [A] to align the number with the arrow mark [B] on the lever holder.
- The distance from the grip to the lever is minimum at number 6 and maximum at number 1.

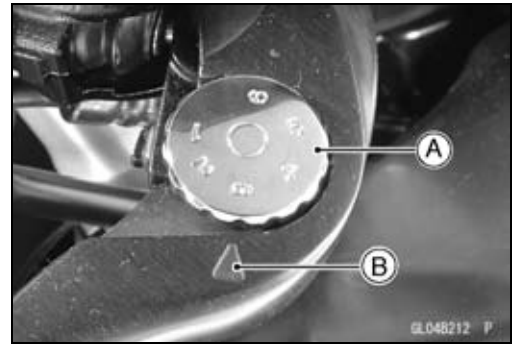

#### **Brake Pedal Position Inspection**

- Check that the brake pedal [A] is in the correct position. Footpeg [B]

##### **Pedal Position**

**Standard:** About 78 mm (3.1 in.) [C] below top of footpeg

- ★ If it is incorrect, adjust the brake pedal position.

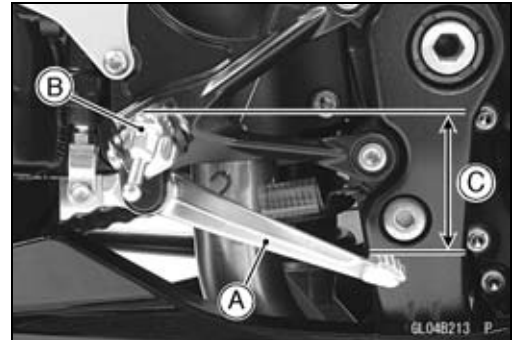

#### **Brake Pedal Position Adjustment**

##### **NOTE**

○ Usually it is not necessary to adjust the pedal position, but always adjust it when push rod locknut has been loosened.

- Loosen the locknut [A] and turn the push rod with the hex head [B] to achieve the correct pedal position.
- ★ If the length [C] shown is  $70 \pm 1$  mm ( $2.8 \pm 0.04$  in.), the pedal position will be within the standard range.
- Tighten:

**Torque - Rear Master Cylinder Push Rod Locknut: 18 N·m (1.8 kgf·m, 13 ft·lb)**

- Check the brake light switch operation (see Brake Light Switch Operation Inspection in the Periodic Maintenance chapter).

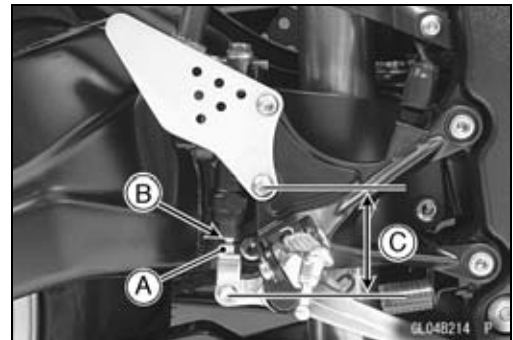

#### **Brake Pedal Removal**

- Remove:
  - Rear Master Cylinder Mounting Bolts [A]
  - Right Footpeg Bracket Bolts [B]

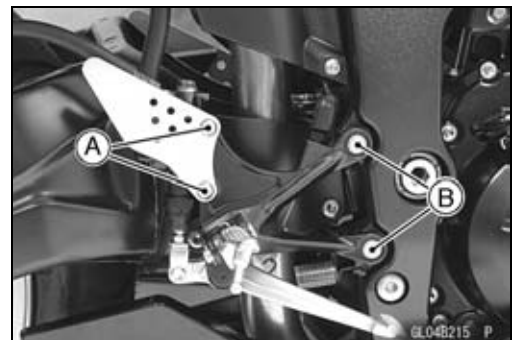

## Brake Lever, Brake Pedal

- Remove:
  - Cotter Pin [A]
  - Joint Pin [B]
  - Rear Brake Light Switch Spring [C]
  - Return Spring [D]
- Remove the mounting bolt [E] and take out the brake pedal.

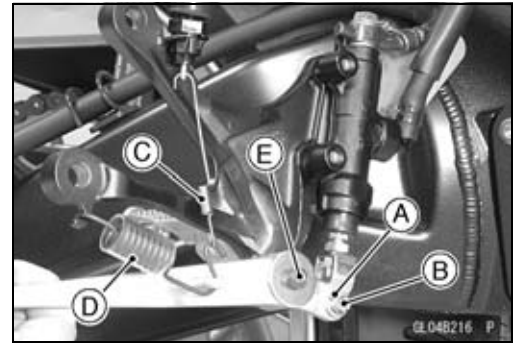

### Brake Pedal Installation

- Apply grease to the pivot shaft [A] and install the washer [B].
- Install:
  - Brake Pedal [C]
  - Washer [D]
  - Brake Pedal Bolt [E]

**Torque - Brake Pedal Bolt: 8.8 N·m (0.90 kgf·m, 78 in·lb)**

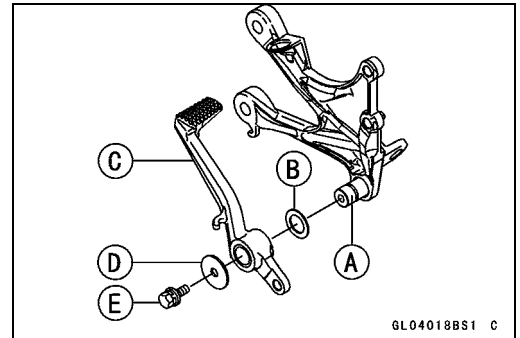

- Hook the upper end of the return spring [A] on the pedal hook.
- Hook the lower end of the rear brake light switch spring [B] on the return spring hook.
- Install the switch spring so that the hook faces outside [C] as shown.
- Footpeg Bracket [D]

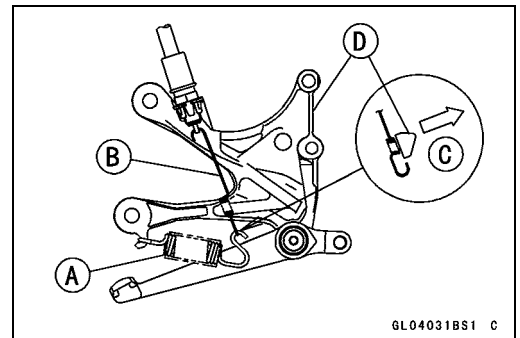

- Replace the cotter pin with a new one.
- Insert the cotter pin [A] and bend the pin ends [B].

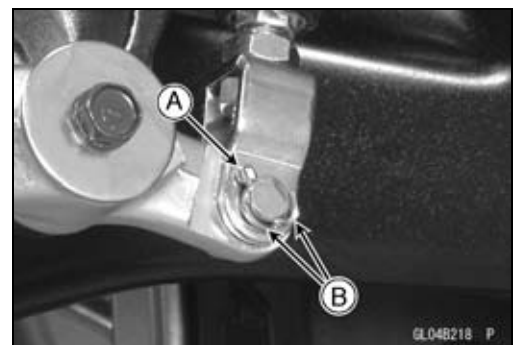

- Install the right footpeg bracket and tighten the bolts.
  - Torque - Front Footpeg Bracket Bolts: 25 N·m (2.5 kgf·m, 18 ft·lb)**
- Depress the brake pedal [A] and then align the bolts holes of the master cylinder [B].
- Tighten:
  - Torque - Rear Master Cylinder Mounting Bolts: 25 N·m (2.5 kgf·m, 18 ft·lb)**
- Check the brake pedal position (see Brake Pedal Position Inspection).

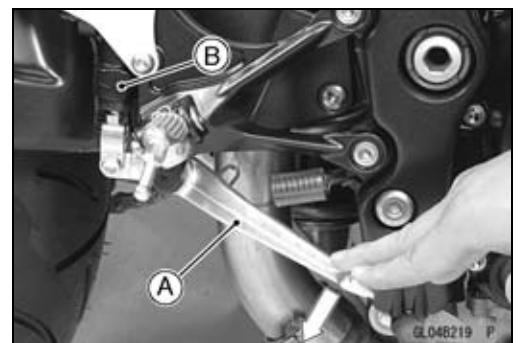

## 12-10 BRAKES

### Calipers

#### Front Caliper Removal

- Loosen the banjo bolt [A] at the brake hose lower end, and tighten it loosely.
- Unscrew the caliper mounting bolts [B], and detach the caliper [C] from the disc.

#### CAUTION

Do not loosen the caliper assembly bolts [D]. Take out only the caliper mounting bolts for caliper removal. Loosening the caliper assembly bolts will cause brake fluid leakage.

- Unscrew the banjo bolt and remove the brake hose [E] from the caliper (see Brake Hose Removal/Installation).

#### CAUTION

Immediately wash away any brake fluid that spills.

#### NOTE

○ If the caliper is to be disassembled after removal and if compressed air is not available, disassemble the caliper before the brake hose is removed (see Front Caliper Disassembly).

#### Rear Caliper Removal

- Loosen the banjo bolt [A] at the brake hose lower end, and tighten it loosely.
- Unscrew the caliper mounting bolts [B], and detach the caliper [C] from the disc.
- Unscrew the banjo bolt and remove the brake hose [D] from the caliper.

#### CAUTION

Immediately wash away any brake fluid that spills.

#### NOTE

○ If the caliper is to be disassembled after removal and if compressed air is not available, disassemble the caliper before the brake hose is removed (see Rear Caliper Disassembly).

#### Caliper Installation

- Install the caliper and brake hose lower end.
- Replace the washers on each side of hose fitting with new ones.
- Tighten:

##### Torque - Caliper Mounting Bolts

Front: 34 N·m (3.5 kgf·m, 25 ft·lb)

Rear: 25 N·m (2.5 kgf·m, 18 ft·lb)

Brake Hose Banjo Bolts: 25 N·m (2.5 kgf·m, 18 ft·lb)

- Check the fluid level in the brake reservoirs.
- Bleed the brake line (see Brake Line Bleeding).
- Check the brake for good braking power, no brake drag, and no fluid leakage.

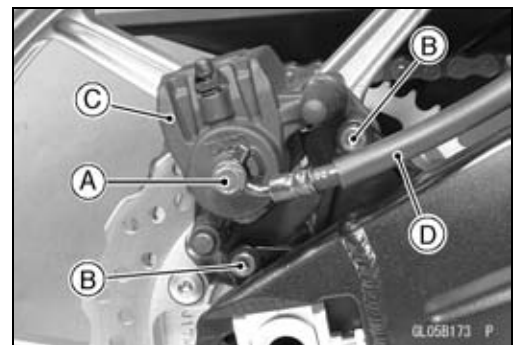
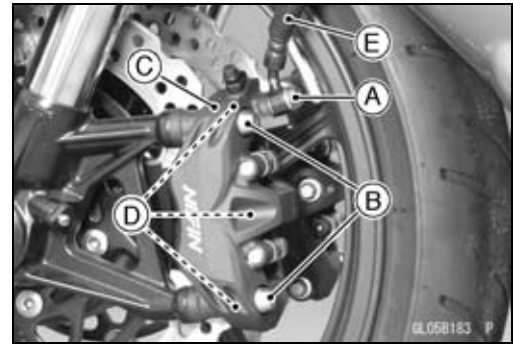

## Calipers

### **⚠ WARNING**

Do not attempt to drive the motorcycle until a full brake lever or pedal is obtained by pumping the brake lever or pedal and the pads are against the disc. The brakes will not function on the first application of the lever or pedal if this is not done.

### **Front Caliper Disassembly**

- Refer to the Caliper Rubber Parts Replacement in the Periodic Maintenance chapter.

### **Front Caliper Assembly**

- Refer to the Caliper Rubber Parts Replacement in the Periodic Maintenance chapter.

### **Rear Caliper Disassembly**

- Refer to the Caliper Rubber Parts Replacement in the Periodic Maintenance chapter.

### **Rear Caliper Assembly**

- Refer to the Caliper Rubber Parts Replacement in the Periodic Maintenance chapter.

### **Caliper Fluid Seal Damage**

The fluid seal (piston seal) [A] is placed around the piston to maintain clearance between the pad and the disc. If the seal is in a poor condition, it could lead the pad to wear excessively or the brake to drag, which may cause the temperature of the discs or the brake fluid to increase.

- Replace the fluid seal if it exhibits any of the conditions listed below.
  - Brake fluid leakage around the pad.
  - Brakes overheat.
  - Considerable difference in inner and outer pad wear.
  - Seal and piston are stuck together.
- ★ If the fluid seal is replaced, replace the dust seal [B] as well. Also, replace all seals every other time the pads are changed.

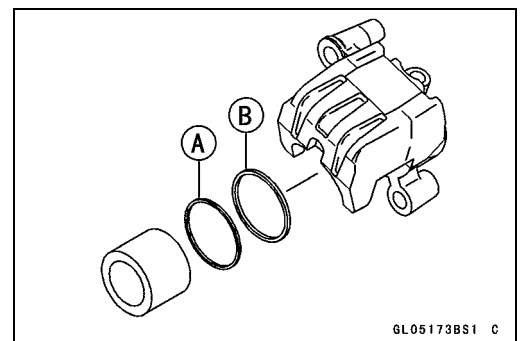
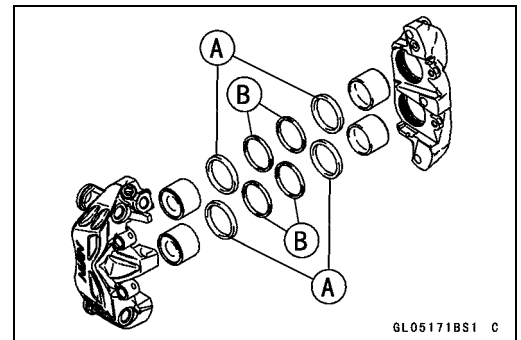

## 12-12 BRAKES

### Calipers

#### **Rear Caliper Dust Boot and Friction Boot Damage**

- Check that the dust boot [A] and friction boot [B] are not cracked, worn, swollen, or otherwise damaged.
- ★ If they show any damage, replace it.

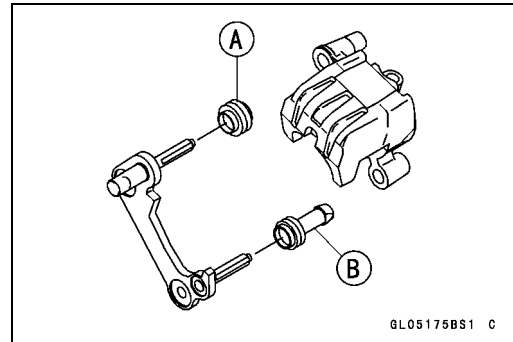

#### **Caliper Piston and Cylinder Damage**

- Visually inspect the pistons [A] and cylinder surfaces [B].
- ★ Replace the caliper if the cylinder and piston are badly scored or rusty.

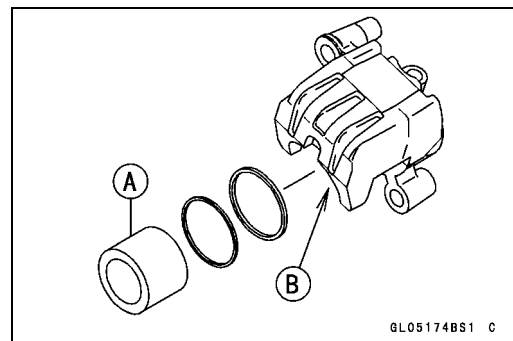
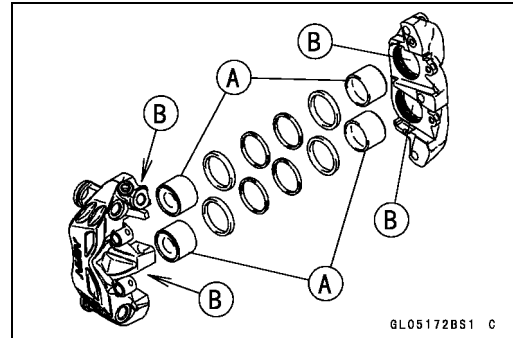

#### **Rear Caliper Holder Shaft Wear**

The caliper body must slide smoothly on the caliper holder shafts [A]. If the body does not slide smoothly, one pad will wear more than the other, pad wear will increase, and constant drag on the disc will raise brake and brake fluid temperature.

- Check to see that the caliper holder shafts are not badly worn or stepped, and that the rubber friction boots are not damaged.
- ★ If the rubber friction boot is damaged, replace the rubber friction boot. To replace the friction boot, remove the pads and the caliper bracket.
- ★ If the caliper holder shaft is damaged, replace the caliper bracket.

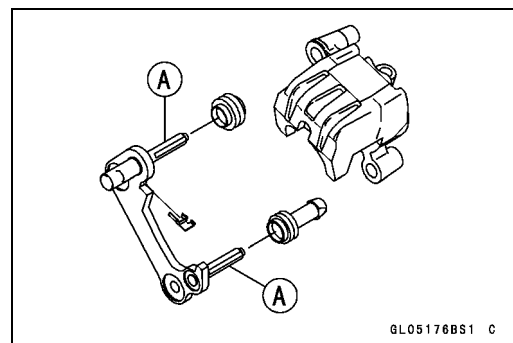

## Brake Pads

### Front Brake Pad Removal

- Remove:
  - Pad Pins [A]
  - Pad Springs [B]
  - Brake Pads [C]

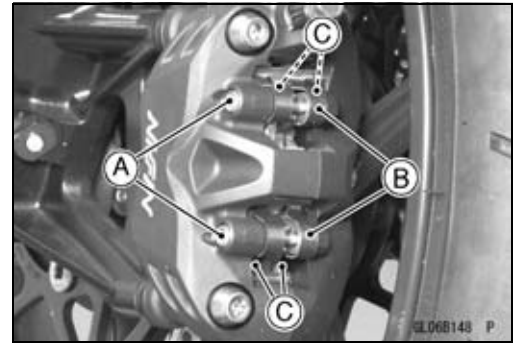

### Front Brake Pad Installation

- Push the caliper pistons in by hand as far as they will go.
- Install the outside pad [A] and insert the pad pin [B] as shown.

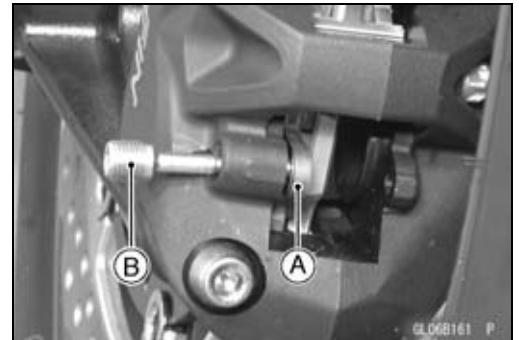

- Set:
  - Inside Pad [A]
  - Pad Spring [B]
- Pushing the pin holder [C] to hole of the pad and insert the pad pin [D].

**Torque - Front Brake Pad Pins: 17 N·m (1.7 kgf·m, 13 ft·lb)**

### **⚠ WARNING**

**Do not attempt to drive the motorcycle until a full brake lever is obtained by pumping the brake lever and the pads are against the disc. The brake will not function on the first application of the lever if this is not done.**

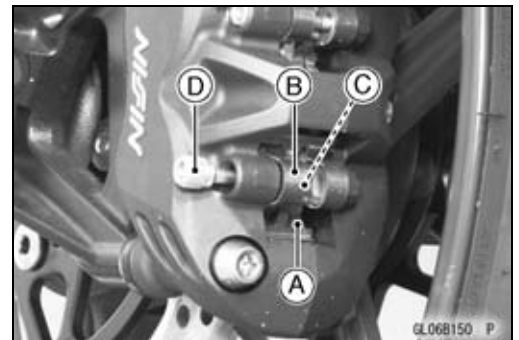

### Rear Brake Pad Removal

- Remove the caliper with the hose installed.
- Remove:
  - Clip [A]
  - Pad Pin [B]
  - Brake Pads [C]

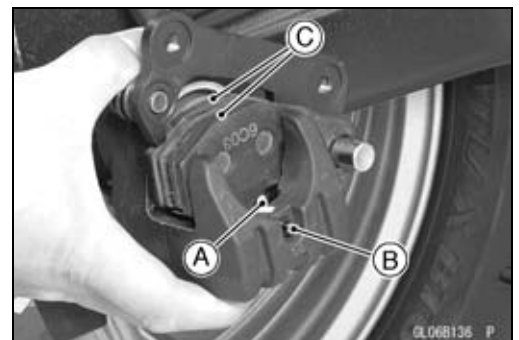

## 12-14 BRAKES

### Brake Pads

#### **Rear Brake Pad Installation**

- Push the caliper piston in by hand as far as it will go.
- Install the pad spring in place.
- Install the piston side pad [A] first, and then another pad.
- Fit the projections [B] of the pad into the recess [C] of the caliper holder.
- Install the pad pin and clip. The clip must be “outside” of the pads.
- Install the caliper (see Caliper Installation).

#### **⚠ WARNING**

**Do not attempt to drive the motorcycle until a full brake pedal is obtained by pumping the brake pedal and the pads are against the disc. The brake will not function on the first application of the pedal if this is not done.**

#### **Brake Pad Wear Inspection**

- Refer to the Brake Pad Wear Inspection in the Periodic Maintenance chapter.

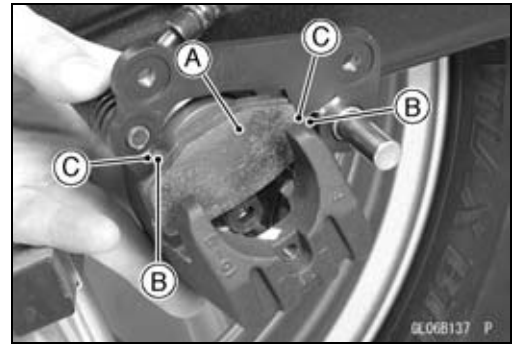



## Master Cylinder

### Front Master Cylinder Removal

- Remove the reservoir bracket nut [A].



- Remove the banjo bolt [A] to disconnect the brake hose from the master cylinder (see Brake Hose Removal/Installation in this chapter).
- Unscrew the clamp bolts [B], and take off the master cylinder [C] as an assembly with the reservoir, brake lever, and brake switch installed.
- Disconnect the front brake light switch connector [D].

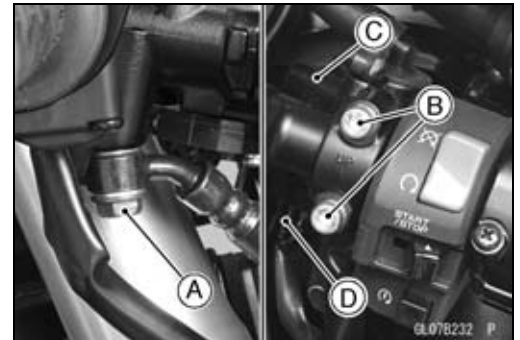

### CAUTION

Immediately wash away any brake fluid that spills.

- Remove:
  - Brake Lever Pivot Bolt [A] and Nut
  - Brake Lever [B]
  - Clamp [C] (Slide Out)
  - Brake Hose [D]
  - Front Brake Light Switch [E]

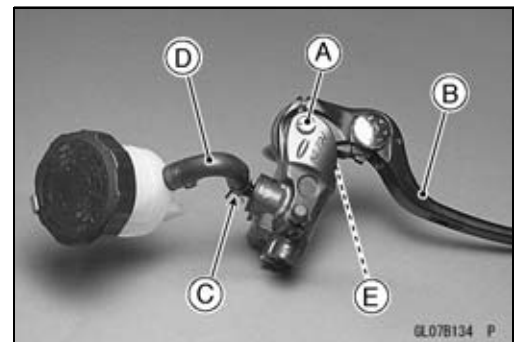

### Front Master Cylinder Installation

- Set the front master cylinder to match its mating surface [A] to the punch mark [B] of the handlebar.
- The master cylinder clamp must be installed with the arrow mark [C] upward.
- Tighten the upper clamp bolt first, and then the lower clamp bolt.

**Torque - Front Master Cylinder Clamp Bolts: 11 N·m (1.1 kgf·m, 97 in·lb)**

- Replace the washers that are on each side of the hose fitting with new ones.
- Tighten:

**Torque - Brake Hose Banjo Bolt: 25 N·m (2.5 kgf·m, 18 ft·lb)**

- Bleed the brake line (see Brake Line Bleeding).
- Check the brake for good braking power, no brake drag, and no fluid leakage.

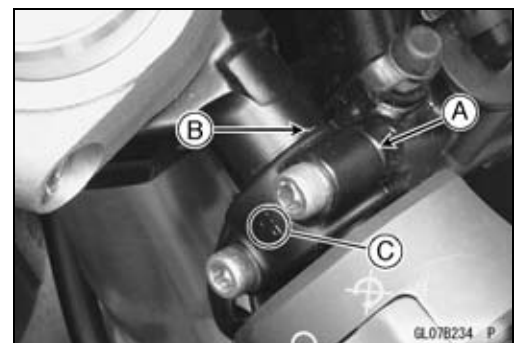

## 12-16 BRAKES

### Master Cylinder

#### **Rear Master Cylinder Removal**

- Unscrew the brake hose banjo bolt [A] and brake hose [B].
- Remove:
  - Cotter Pin [C]
  - Joint Pin [D]
  - Bolts [E]
  - Foot Guard [F]
  - Rear Master Cylinder
- Slide out the clamp [G].
- Pull off the reservoir hose lower end [H], and drain the brake fluid into a container.

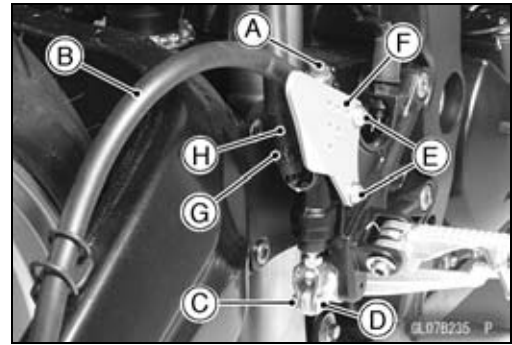

#### **Rear Master Cylinder Installation**

- Replace the cotter pin with a new one.
- Replace the washers that are on each side of hose fitting with new ones.
- Tighten:
  - **Torque - Rear Master Cylinder Mounting Bolts: 25 N·m (2.5 kgf·m, 18 ft·lb)**
  - **Brake Hose Banjo Bolt: 25 N·m (2.5 kgf·m, 18 ft·lb)**
- Bleed the brake line (see Brake Line Bleeding).
- Check the brake for good braking power, no brake drag, and no fluid leakage.

#### **Front Master Cylinder Disassembly**

- Refer to the Master Cylinder Rubber Parts Replacement in the Periodic Maintenance chapter.

#### **Rear Master Cylinder Disassembly**

- Refer to the Master Cylinder Rubber Parts Replacement in the Periodic Maintenance chapter.

#### **Master Cylinder Inspection (Visual Inspection)**

- Remove the master cylinders (see Front/Rear Master Cylinder Removal).
  - Disassemble the front and rear master cylinders (see Master Cylinder Rubber Parts Replacement in the Periodic Maintenance chapter).
  - Check that there are no scratches, rust or pitting on the inner wall [A] of each master cylinder and on the outside of each piston [B].
  - ★ If a master cylinder or piston shows any damage, replace them.
  - Inspect the primary cup [C] and secondary cup [D].
  - ★ If a cup is worn, damaged softened (rotted), or swollen, the piston assembly should be replaced to renew the cups.
  - ★ If fluid leakage is noted at the brake lever, the piston assembly should be replaced to renew the cups.
- Front Master Cylinder [I]

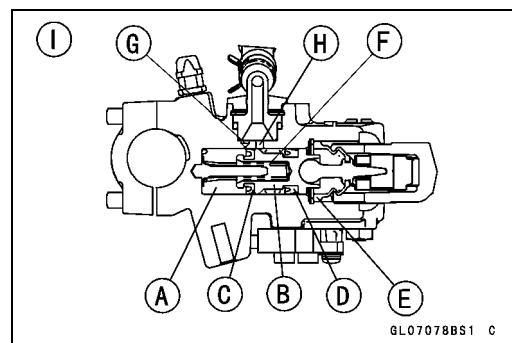

## Master Cylinder

- Check the dust covers [E] for damage.
- ★ If they are damaged, replace them.
- Check the piston return spring [F] for any damage.
- ★ If the springs are damaged, replace them.
- Check that relief port [G] and supply port [H] are not plugged.
- ★ If the relief port becomes plugged, the brake pads will drag on the disc. Blow the ports clean with compressed air.

Rear Master Cylinder [J]

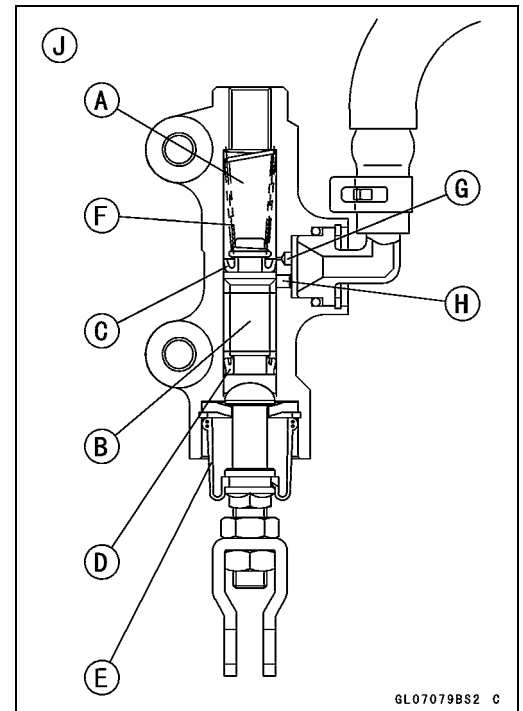

### **Master Cylinder Assembly**

- Refer to the Master Cylinder Rubber Parts Replacement in the Periodic Maintenance chapter.

## 12-18 BRAKES

### Brake Disc

#### **Brake Disc Removal**

- Remove the wheel (see Front/Rear Wheel Removal in the Wheels/Tires chapter).
- Unscrew the mounting bolts, and take off the disc.

#### **Brake Disc Installation**

- Install the brake disc on the wheel so that the marked side [B] faces out.
- Apply a non-permanent locking agent to the threads of the rear brake disc mounting bolts [A].
- Tighten:

**Torque - Brake Disc Mounting Bolts: 27 N·m (2.8 kgf·m, 20 ft·lb)**

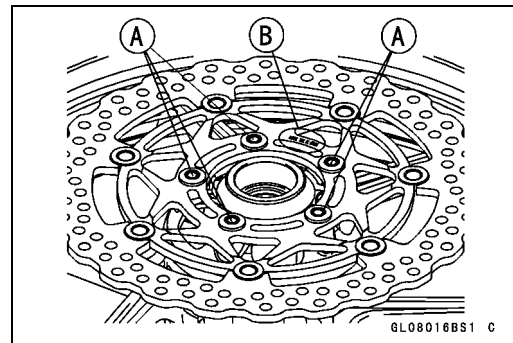

#### **Brake Disc Wear**

- Measure the thickness of each disc [A] at the point where it has worn the most.
  - ★ If the disc has worn past the service limit, replace it.
- Measuring Area [B]

#### **Brake Discs Thickness**

##### **Standard:**

Front	5.8 ~ 6.2 mm (0.23 ~ 0.24 in.)
Rear	4.8 ~ 5.2 mm (0.19 ~ 0.20 in.)

##### **Service Limit:**

Front	5.5 mm (0.22 in.)
Rear	4.5 mm (0.18 in.)

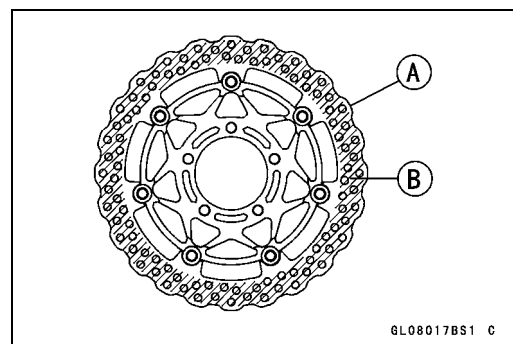

#### **Brake Disc Warp**

- Jack up the motorcycle so that the wheel is off the ground.

**Special Tools - Jack: 57001-1238**

**Jack Attachment: 57001-1608**

- For front disc inspection, turn the handlebar fully to one side.

- Set up a dial gauge against the disc [A] as shown and measure disc runout, while turning [B] the wheel by hand.

- ★ If runout exceeds the service limit, replace the disc.

#### **Disc Runout**

<b>Standard:</b>	<b>TIR 0.15 mm (0.006 in.) or less</b>
<b>Service Limit:</b>	<b>TIR 0.3 mm (0.01 in.)</b>

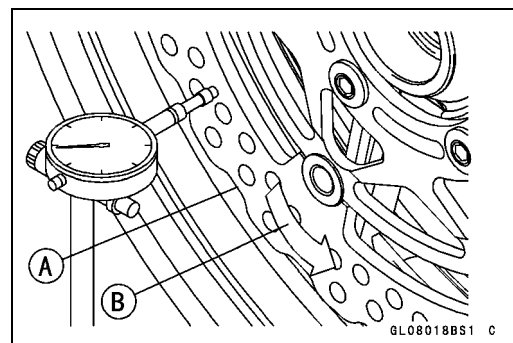

## Brake Fluid

### **Brake Fluid Level Inspection**

- Refer to the Brake Fluid Level Inspection in the Periodic Maintenance chapter.

### **Brake Fluid Change**

- Refer to the Brake Fluid Change in the Periodic Maintenance chapter.

### **Brake Line Bleeding**

The brake fluid has a very low compression coefficient so that almost all the movement of the brake lever or pedal is transmitted directly to the caliper for braking action. Air, however, is easily compressed. When air enters the brake lines, brake lever or pedal movement will be partially used in compressing the air. This will make the lever or pedal feel spongy, and there will be a loss in braking power.

#### **⚠ WARNING**

**Be sure to bleed the air from the brake line whenever brake lever or pedal action feels soft or spongy after the brake fluid is changed, or whenever a brake line fitting has been loosened for any reason.**

#### **NOTE**

○ *The procedure to bleed the front brake line is as follows. Bleeding the rear brake line is the same as for the front brake.*

- Remove:
  - Screw [A]
  - Clamp [B]
  - Front Brake Reservoir Cap [C]
  - Diaphragm Plate
  - Diaphragm
- Fill the reservoir with fresh brake fluid to the upper level line in the reservoir.
- With the reservoir cap off, slowly pump the brake lever several times until no air bubbles can be seen rising up through the fluid from the holes at the bottom of the reservoir.
- Bleed the air completely from the master cylinder by this operation.
- Remove the rubber cap from the bleed valve on the front master cylinder.
- Attach a clear plastic hose [A] to the bleed valve, and run the other end of the hose into a container.

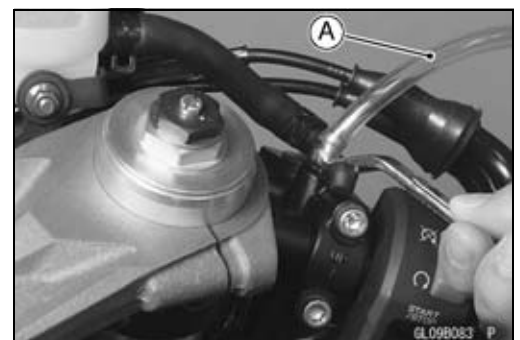

## 12-20 BRAKES

### Brake Fluid

- Bleed the brake line and the master cylinder.
- Repeat this operation until no more air can be seen coming out into the plastic hose.
  1. Pump the brake lever until it becomes hard, and apply the brake and hold it [A].
  2. Quickly open and close [B] the bleed valve while holding the brake applied.
  3. Release the brake [C].

#### NOTE

- *The fluid level must be checked often during the bleeding operation and replenished with fresh brake fluid as necessary. If the fluid in the reservoir runs completely out any time during bleeding, the bleeding operation must be done over again from the beginning since air will have entered the line.*

- Remove the clear plastic hose.
- Tighten the bleed valve, and install the rubber cap.

**Torque - Front Master Cylinder Bleed Valve: 5.9 N·m (0.60 kgf·m, 52 in·lb)**

- Remove the rubber cap from the bleed valve [A] on the caliper.
- Attach a clear plastic hose [B] to the bleed valve, and run the other end of the hose into a container.

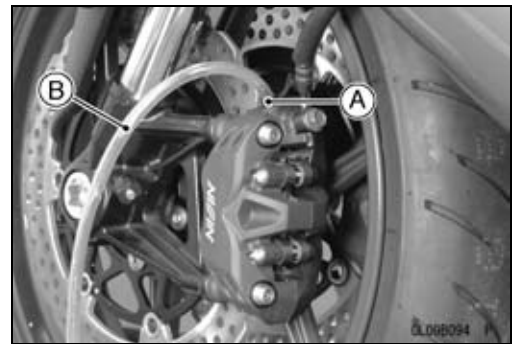
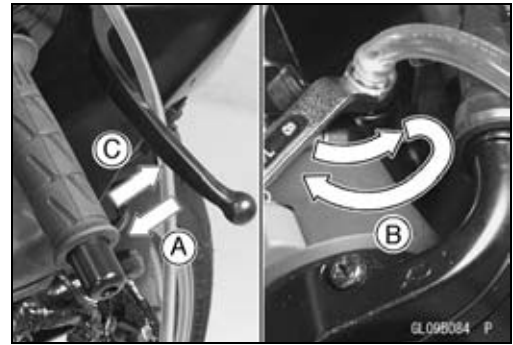

- Bleed the brake line and the caliper.
- Repeat this operation until no more air can be seen coming out into the plastic hose.
  1. Pump the brake lever until it becomes hard, and apply the brake and hold it [A].
  2. Quickly open and close [B] the bleed valve while holding the brake applied.
  3. Release the brake [C].

#### NOTE

- *The fluid level must be checked often during the bleeding operation and replenished with fresh brake fluid as necessary. If the fluid in the reservoir runs completely out any time during bleeding, the bleeding operation must be done over again from the beginning since air will have entered the line.*

○ *Tap the brake hose lightly from the caliper to the reservoir for more complete bleeding.*

○ *Front Brake: First bleeding the right caliper then repeat the above steps for the left caliper.*

- Remove the clear plastic hose.

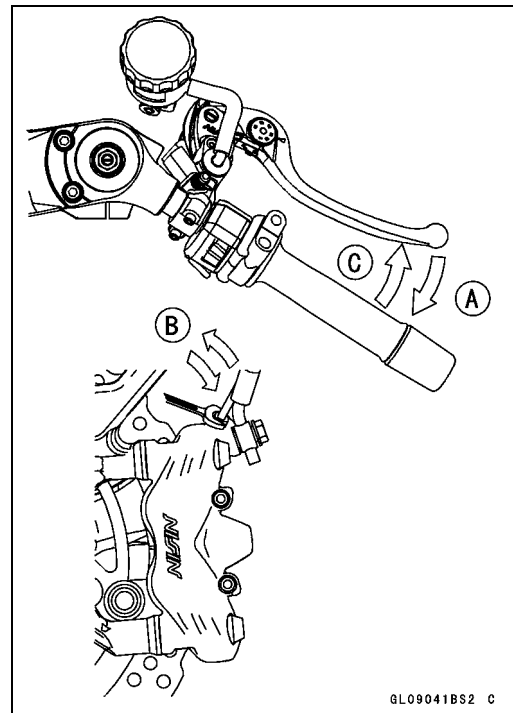

## Brake Fluid

- Install:

- Diaphragm [A]
- Diaphragm Plate [B]
- Front Brake Reservoir Cap [C]

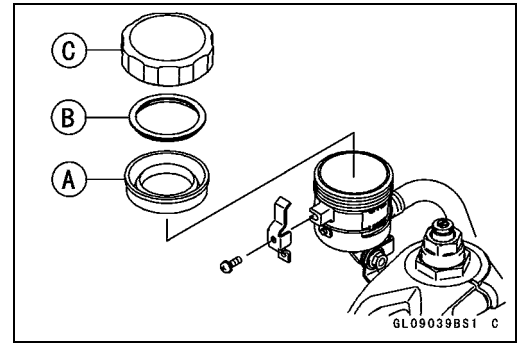

- Follow the procedure below to install the front/rear brake fluid reservoir cap correctly.

- First, tighten the brake fluid reservoir cap [B] clockwise [C] by hand until the resistance is felt fully; then, tighten the cap an additional 1/6 turn [D] while holding the brake fluid reservoir body [A].

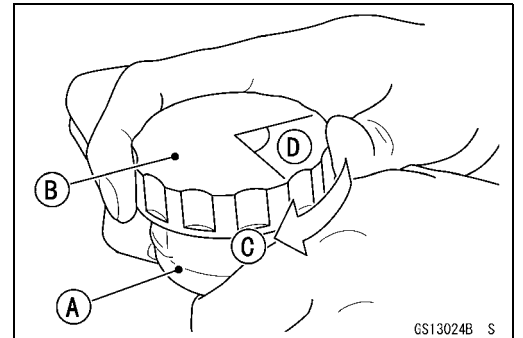

- Tighten:

**Torque - Front Brake Reservoir Cap Stopper Screw: 1.2 N·m (0.12 kgf·m, 11 in·lb)**

- Tighten the bleed valve, and install the rubber cap.

**Torque - Bleed Valve: 7.8 N·m (0.80 kgf·m, 69 in·lb)**

- Check the fluid level (see Brake Fluid Level Inspection in the Periodic Maintenance chapter).
- After bleeding is done, check the brake for good braking power, no brake drag, and no fluid leakage.

## 12-22 BRAKES

### Brake Fluid

#### **WARNING**

**When working with the disc brake, observe the precautions listed below.**

1. Never reuse old brake fluid.
2. Do not use fluid from a container that has been left unsealed or that has been open for a long time.
3. Do not mix two types and brands of fluid for use in the brake. This lowers the brake fluid boiling point and could cause the brake to be ineffective. It may also cause the rubber brake parts to deteriorate.
4. Don't leave the reservoir cap off for any length of time to avoid moisture contamination of the fluid.
5. Don't change the fluid in the rain or when a strong wind is blowing.
6. Except for the disc pads and disc, use only disc brake fluid, isopropyl alcohol, or ethyl alcohol for cleaning of the brake parts. Do not use any other fluid for cleaning these parts. Gasoline, engine oil, or any other petroleum distillate will cause deterioration of the rubber parts. Oil spilled on any part will be difficult to wash off completely and will eventually deteriorate the rubber used in the disc brake.
7. When handling the disc pads or disc, be careful that no disc brake fluid or any oil gets on them. Clean off any fluid or oil that inadvertently gets on the pads or disc with a high-flash point solvent. Do not use one which will leave an oily residue. Replace the pads with new ones if they cannot be cleaned satisfactorily.
8. Brake fluid quickly ruins painted surfaces; any spilled fluid should be completely wiped up immediately.
9. If any of the brake line fittings or the bleed valve is opened at any time, the **AIR MUST BE BLED FROM THE BRAKE LINE.**



**Brake Hose**

---

***Brake Hose Removal/Installation***

- Refer to the Brake Hose and Pipe Replacement in the Periodic Maintenance chapter.

***Brake Hose Inspection***

- Refer to the Brake Hose Damage and Installation Condition Inspection in the Periodic Maintenance chapter.



# Suspension

## Table of Contents

Exploded View .....	13-2
Specifications .....	13-6
Special Tools .....	13-7
Front Fork .....	13-9
Rebound Damping Force Adjustment .....	13-9
Spring Preload Adjustment .....	13-9
Compression Damping Force Adjustment .....	13-10
Front Fork Removal (Each Fork Leg) .....	13-10
Front Fork Installation .....	13-11
Front Fork Oil Change .....	13-11
Front Fork Disassembly .....	13-15
Front Fork Assembly .....	13-16
Inner Tube Inspection .....	13-17
Dust Seal Inspection .....	13-18
Spring Tension .....	13-18
Rear Shock Absorber .....	13-19
Rebound Damping Force Adjustment .....	13-19
Compression Damping Force Adjustment .....	13-19
Spring Preload Adjustment .....	13-20
Rear Shock Absorber Removal .....	13-21
Rear Shock Absorber Installation .....	13-21
Rear Shock Absorber Inspection .....	13-21
Rear Shock Absorber Scrapping .....	13-22
Swingarm.....	13-23
Swingarm Removal.....	13-23
Swingarm Installation.....	13-24
Swingarm Bearing Removal .....	13-25
Swingarm Bearing Installation .....	13-25
Swingarm Bearing, Sleeve Inspection .....	13-26
Chain Guide Inspection.....	13-26
Tie-Rod, Rocker Arm .....	13-27
Tie-Rod Removal .....	13-27
Tie-Rod Installation .....	13-27
Rocker Arm Removal.....	13-27
Rocker Arm Installation.....	13-28
Tie-Rod and Rocker Arm Bearing Removal.....	13-29
Tie-Rod and Rocker Arm Bearing Installation.....	13-29
Rocker Arm/Tie-Rod Bearing, Sleeve Inspection .....	13-31
Rocker Arm/Tie-Rod Bearing Lubrication .....	13-31

# 13-2 SUSPENSION

## Exploded View

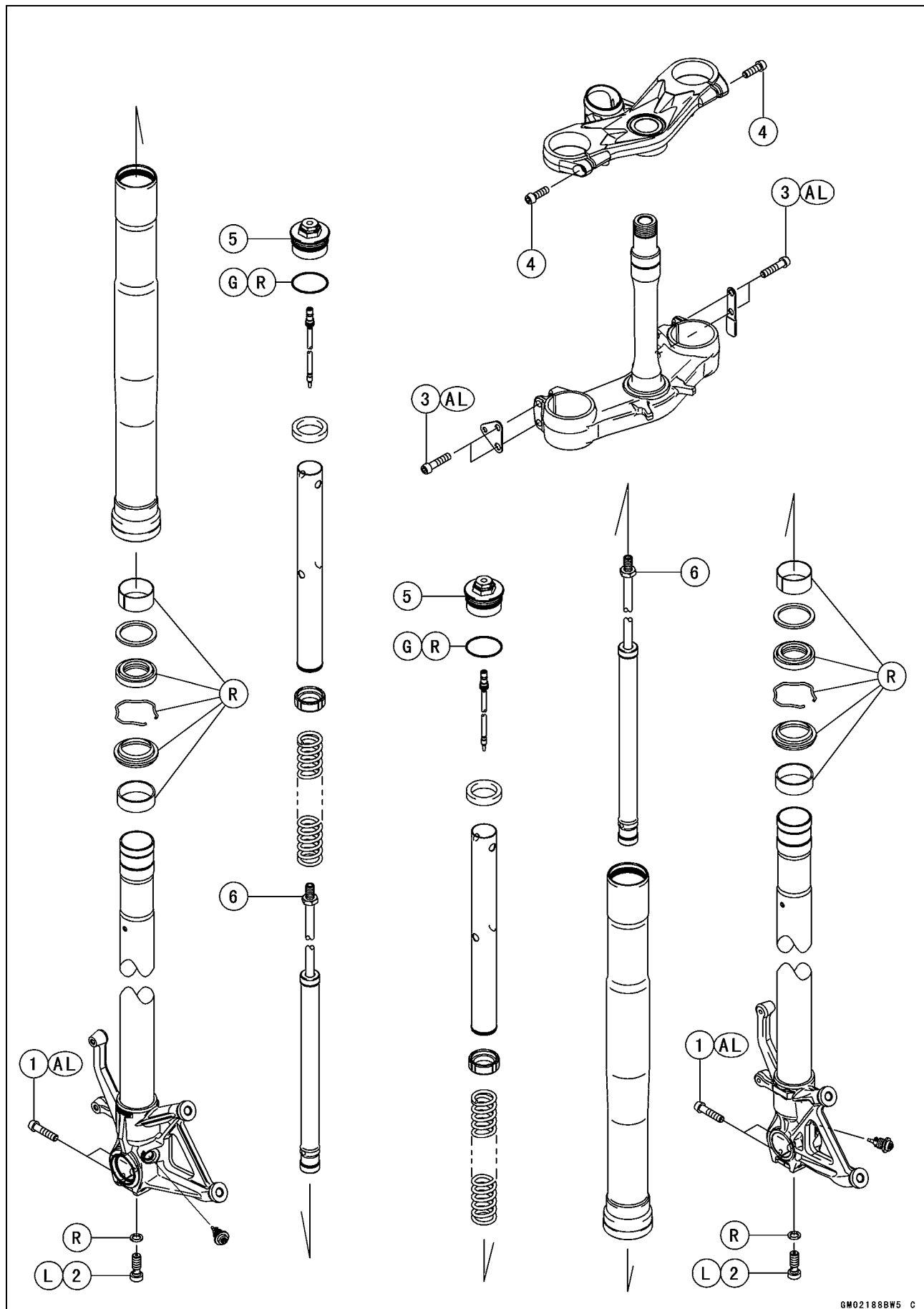

**Exploded View**

No.	Fastener	Torque			Remarks
		N-m	kgf-m	ft-lb	
1	Front Axle Clamp Bolts	20	2.0	15	AL
2	Front Fork Bottom Allen Bolts	35	3.5	26	
3	Front Fork Clamp Bolts (Lower)	25	2.5	18	AL
4	Front Fork Clamp Bolts (Upper)	20	2.0	15	
5	Front Fork Top Plugs	35	3.5	26	
6	Piston Rod Nuts	20	2.0	15	

AL: Tighten the two clamp bolts alternately two times to ensure even tightening torque.

G: Apply grease.

L: Apply a non-permanent locking agent.

R: Replacement Parts



**Exploded View**

No.	Fastener	Torque			Remarks
		N·m	kgf·m	ft·lb	
1	Rear Shock Absorber Bracket Nut	59	6.0	43	
2	Rear Shock Absorber Nut (Lower)	34	3.5	25	
3	Rear Shock Absorber Nut (Upper)	34	3.5	25	
4	Swingarm Pivot Adjusting Collar	20	2.0	15	S
5	Swingarm Pivot Adjusting Collar Locknut	98	10	72	S
6	Swingarm Pivot Shaft Nut	108	11	81	S
7	Tie-Rod Nuts	59	6.0	43	
8	Uni-Trak Rocker Arm Nut	34	3.5	25	

G: Apply grease.

L: Apply a non-permanent locking agent.

R: Replacement Parts

S: Follow the specified tightening sequence.

## 13-6 SUSPENSION

### Specifications

Item	Standard
<b>Front Fork (Per One Unit)</b> Fork Inner Tube Diameter Air Pressure Rebound Damper Setting Compression Damper Setting Fork Spring Preload Setting Fork Oil: Viscosity Amount: When Changing Oil After Disassembly and Completely Dry Fork Oil Level: (Fully Compressed, without Spring, below from the Top of the Outer Tube) Fork Spring Free Length	$\phi 41$ mm (1.6 in.) Atmospheric pressure (non-adjustable) 1 1/2 turns out from the fully clockwise position (Usable range: 0 $\longleftrightarrow$ 3 1/2 turns out) 1 1/2 turns out from the fully clockwise position (Usable range: 0 $\longleftrightarrow$ 3 turns out) 5 turns in from the fully counterclockwise position (Usable range: 0 $\longleftrightarrow$ 15 turns in) SHOWA SS47 or equivalent SAE 10W Approx. 430 mL (14.5 US oz.) 505 $\pm 2.5$ mL (17.1 $\pm 0.085$ US oz.) 97 $\pm 2$ mm (3.8 $\pm 0.08$ in.) 257 mm (10.1 in.) (Service Limit: 252 mm (9.92 in.))
<b>Rear Shock Absorber</b> Rebound Damper Setting Compression Damper Setting: High Speed Low Speed Spring Preload Setting Position: Standard Usable Range Gas Pressure	19th click from the first click of the fully clockwise position (Usable range: 0 $\longleftrightarrow$ 25th click) 2 1/2 turns out from the fully clockwise position (Usable range: 0 $\longleftrightarrow$ 4 turns out) 2 turns out from the fully clockwise position (Usable range: 0 $\longleftrightarrow$ 5 turns out) Spring length: 180 mm (7.09 in.) Spring length: 175 ~ 185 mm (6.89 ~ 7.28 in.) (stronger to weaker) 980 kPa (10.0 kgf/cm <sup>2</sup> , 142 psi, non-adjustable)



Special Tools

Inside Circlip Pliers:  
57001-143

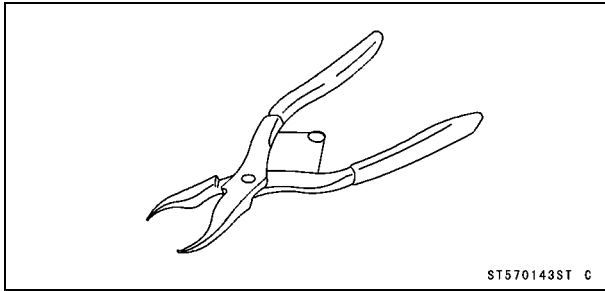

ST570143ST C

Fork Oil Level Gauge:  
57001-1290

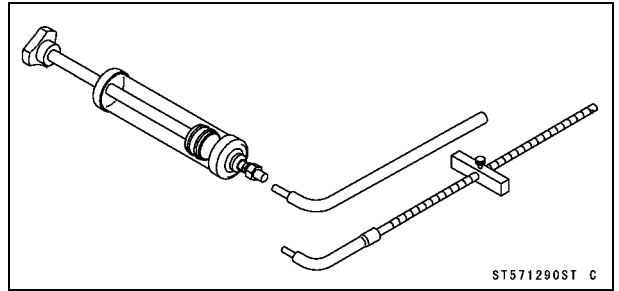

ST571290ST C

Oil Seal & Bearing Remover:  
57001-1058

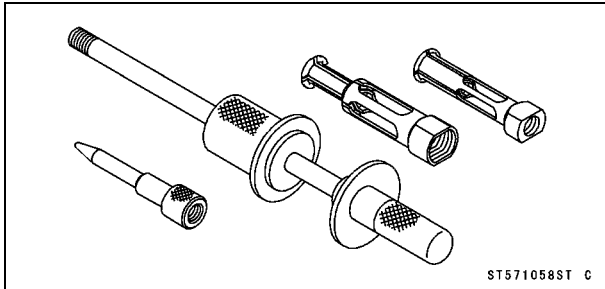

ST571058ST C

Fork Piston Rod Puller, M10 x 1.0:  
57001-1298

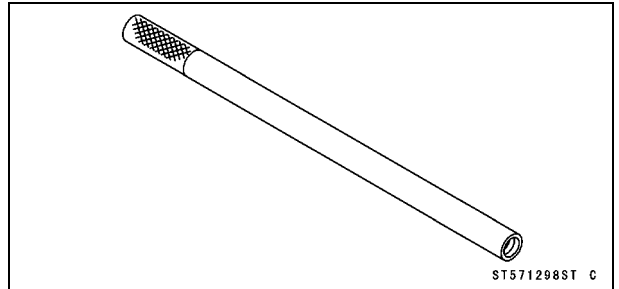

ST571298ST C

Bearing Driver Set:  
57001-1129

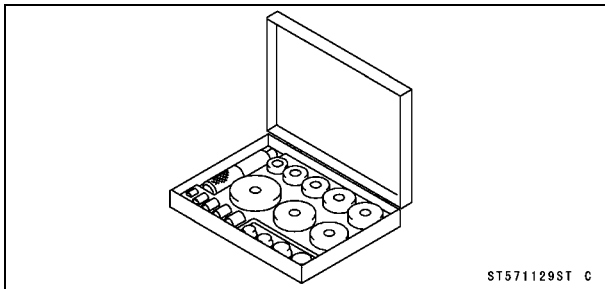

ST571129ST C

Fork Spring Stopper:  
57001-1374

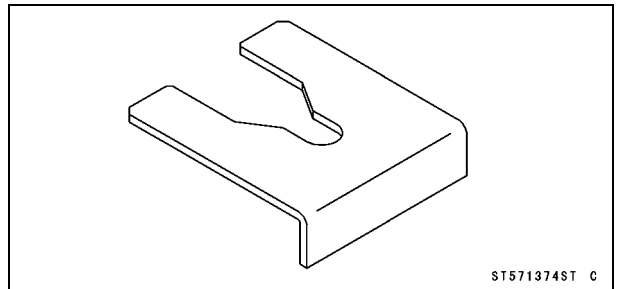

ST571374ST C

Jack:  
57001-1238

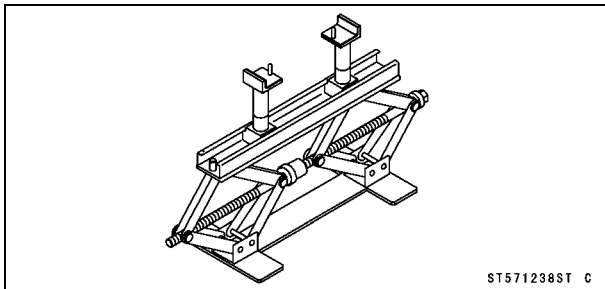

ST571238ST C

Bearing Remover Shaft,  $\phi 13$ :  
57001-1377

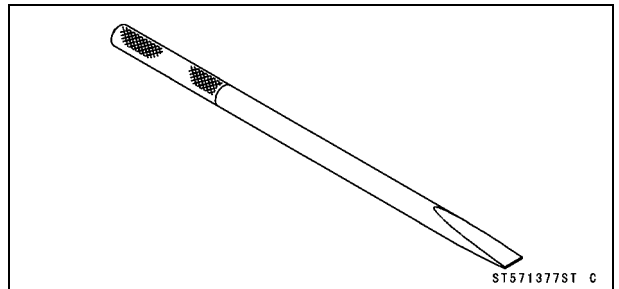

ST571377ST C

Fork Oil Seal Driver,  $\phi 41$ :  
57001-1288

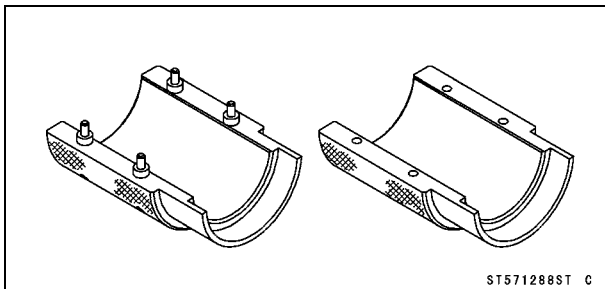

ST571288ST C

Hook Wrench T=3.2 R37:  
57001-1539

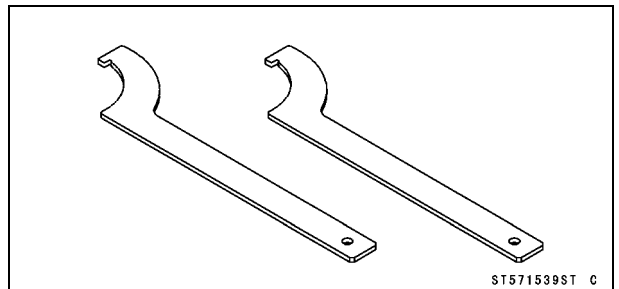

ST571539ST C

# 13-8 SUSPENSION

## Special Tools

**Swingarm Pivot Nut Wrench:**  
57001-1597

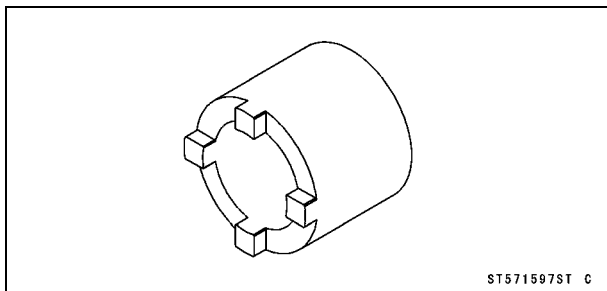

**Spacer,  $\phi 18$ :**  
57001-1636

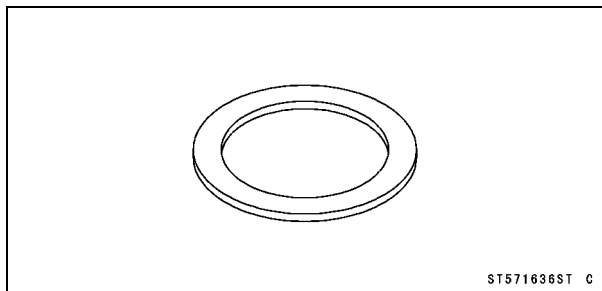

**Jack Attachment:**  
57001-1608

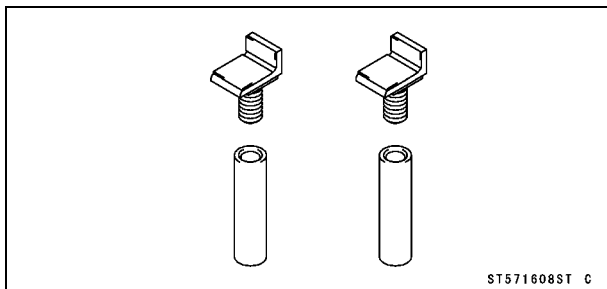

**Spacer,  $\phi 28$ :**  
57001-1637

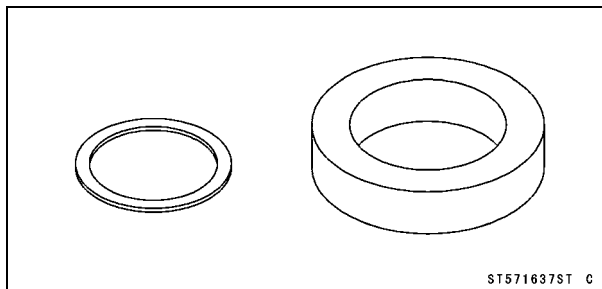

**Needle Bearing Driver,  $\phi 17/\phi 18$ :**  
57001-1609

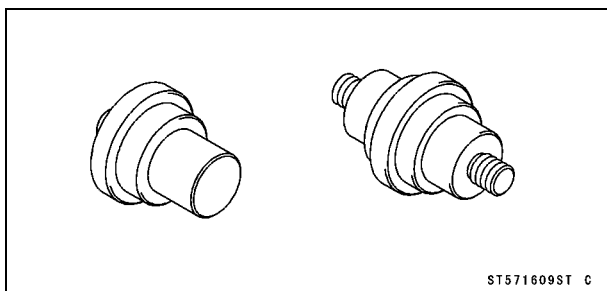

**Fork Spring Compressor:**  
57001-1685

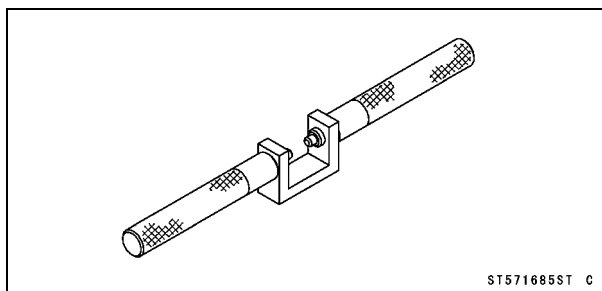

**Stem Bearing Driver,  $\phi 28$ :**  
57001-1610

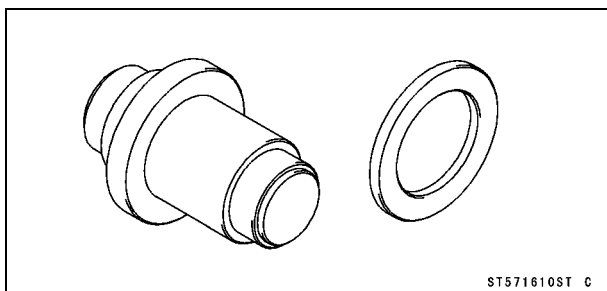

**Front Fork**

**Rebound Damping Force Adjustment**

- To adjust the rebound damping force, turn the rebound damping adjuster [A] on top of the right front fork leg to the desired position.
- The standard adjuster setting for the average-build rider of 68 kg (150 lb) with no passenger and no accessories is **1 1/2 turns out** from the fully clockwise position.

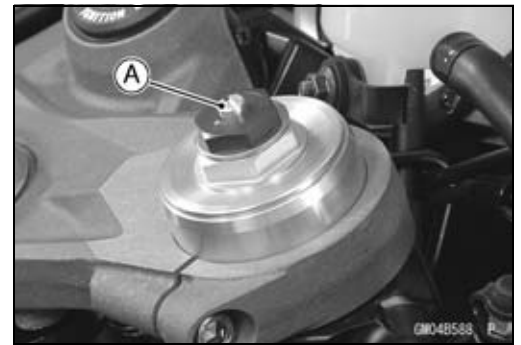

- The damping force can be left soft for average riding. But it should be adjusted harder for high speed riding or riding with a passenger. If the damping feels too soft or too stiff, adjust it in accordance with the following table.

**Rebound Damping Force Adjustment**

Adjuster Position	Damping Force	Setting	Load	Road	Speed
3 1/2 Turns Out	Weak	Soft	Light	Good	Low
↑	↑	↑	↑	↑	↑
↓	↓	↓	↓	↓	↓
0	Strong	Hard	Heavy	Bad	High

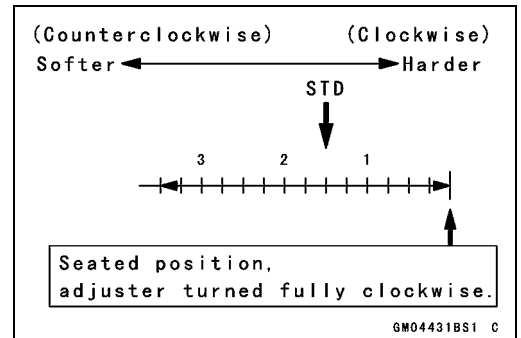

**Spring Preload Adjustment**

- Turn the spring preload adjuster [A] to change spring preload setting.
- The standard adjuster setting for the average-build rider of 68 kg (150 lb) with no passenger and no accessories is **5 turns in** from the fully counterclockwise position.

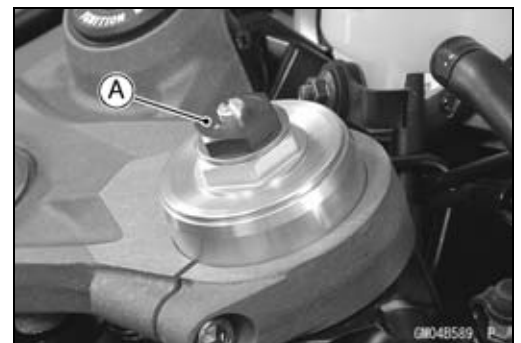

**⚠ WARNING**

**If both adjusters are not adjusted equally, handling may be impaired and a hazardous condition may result.**

- The spring preload can be left soft for average riding. But it should be adjusted harder for high speed riding or riding with a passenger. If the spring action feels too soft or too stiff, adjust it in accordance with the following table.

**Spring Action**

Adjuster Position	Damping Force	Setting	Load	Road	Speed
0	Weak	Soft	Light	Good	Low
↑	↑	↑	↑	↑	↑
↓	↓	↓	↓	↓	↓
15 Turns Out	Strong	Hard	Heavy	Bad	High

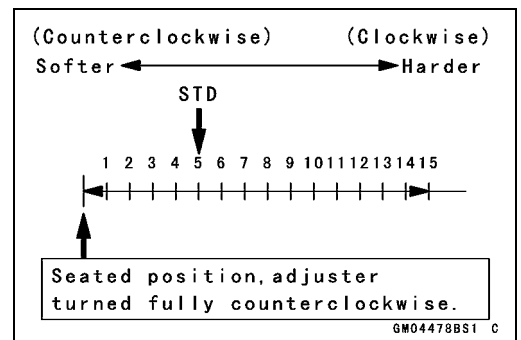

# 13-10 SUSPENSION

## Front Fork

### Compression Damping Force Adjustment

- To adjust the compression damping force, turn the compression damping adjuster [A] until you feel a click.
- The standard adjuster setting for the average-build rider of 68 kg (150 lb) with no passenger and no accessories is the 1 1/2 turn out from the fully clockwise position.



**⚠ WARNING**

**If both adjusters are not adjusted equally, handling may be impaired and a hazardous condition may result.**

- The damping force can be left soft for average riding. But it should be adjusted harder for high speed riding or riding with a passenger. If the damping feels too soft or too stiff, adjust it in accordance with the following table.

### Compression Damping Force Adjustment

Adjuster Position	Damping Force	Setting	Load	Road	Speed
3 Turns Out	Weak	Soft	Light	Good	Low
↑	↑	↑	↑	↑	↑
↓	↓	↓	↓	↓	↓
0	Strong	Hard	Heavy	Bad	High

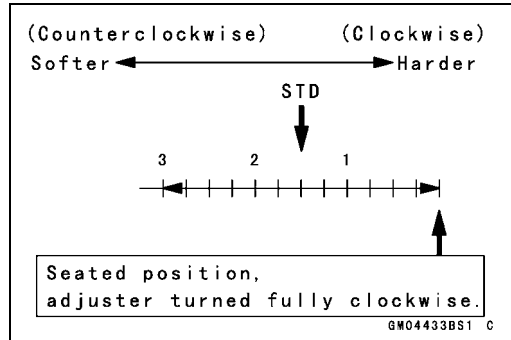

### Front Fork Removal (Each Fork Leg)

- Remove:
  - Middle Fairings (see Middle Fairing Removal in the Frame chapter)
  - Upper Inner Fairings (see Upper Inner Fairing Removal in the Frame chapter)
  - Front Wheel (see Front Wheel Removal in the Wheels/Tires chapter)
  - Front Fender (see Front Fender Removal in the Frame chapter)

- ★ Loosen the handlebar bolt [A], upper fork clamp bolt [B] and fork top plug [C] beforehand if the fork leg is to be disassembled.

**NOTE**

- Loosen the top plug after loosening the handlebar bolt and upper fork clamp bolt.

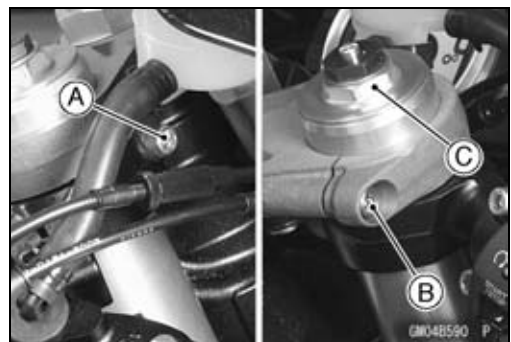

## Front Fork

- Loosen the handlebar bolt, upper fork clamp bolt and lower fork clamp bolts [A].
- With a twisting motion, work the fork leg down and out.

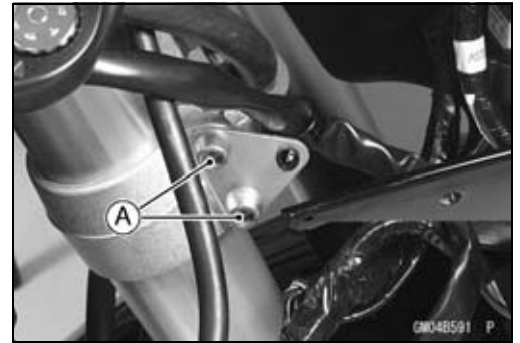

### Front Fork Installation

- Install the fork so that the top end [A] of the outer tube as shown.  
8.5 mm (0.33 in.) [B]
- Tighten the lower fork clamp bolts and fork top plug.  
**Torque - Front Fork Clamp Bolts (Lower): 25 N·m (2.5 kgf·m, 18 ft·lb)**  
**Front Fork Top Plug: 35 N·m (3.5 kgf·m, 26 ft·lb)**
- Tighten the handlebar bolt and upper fork clamp bolt.  
**Torque - Handlebar Bolt: 25 N·m (2.5 kgf·m, 18 ft·lb)**  
**Front Fork Clamp Bolt (Upper): 20 N·m (2.0 kgf·m, 15 ft·lb)**

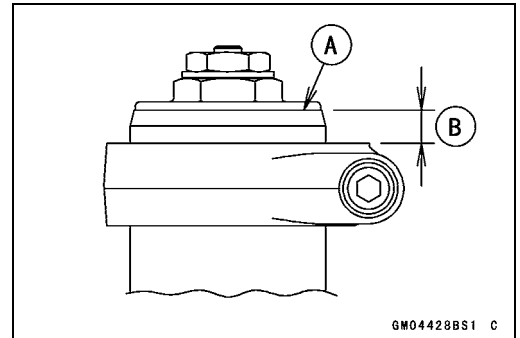

### NOTE

- Tighten the two clamp bolts alternately two times to ensure even tightening torque.
- Tighten the top plug before tightening the handlebar bolt and upper fork clamp bolt.
- Install the removed parts (see appropriate chapters).
- Adjust the spring preload and the damping force.

### Front Fork Oil Change

- Remove the front fork (see Front Fork Removal).
- Hold the inner tube lower end in a vice.
- Unscrew the top plug [A] out of the outer tube.

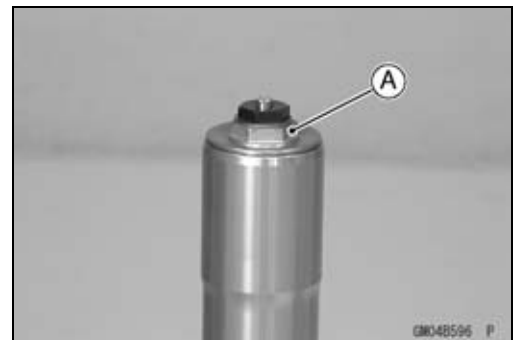

- Install the fork spring compressor as shown.

### NOTE

- Set the fork spring compressor so that the end of the handle [A] passes the upper side hole on the spacer [B] by screwing the handle in the holder [C] to the bottom.

**Special Tool - Fork Spring Compressor: 57001-1685**

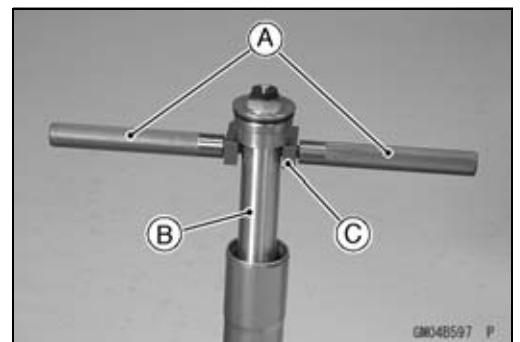

## 13-12 SUSPENSION

### Front Fork

- While holding up the top plug [A] by one person, push down [B] the fork spring compressor and insert the fork spring stopper [C] between the piston rod nut [D] and the spacer [E].

**Special Tool - Fork Spring Stopper: 57001-1374**

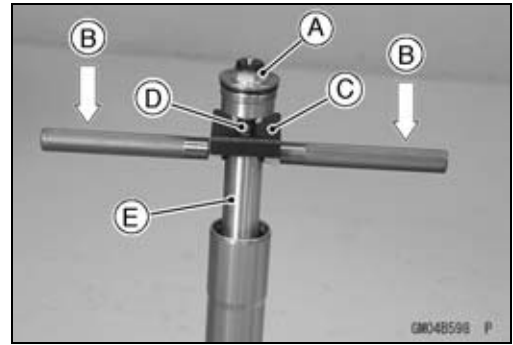

- Holding the spring preload adjuster [A] with a wrench [B], loosen the piston rod nut [C].
- Remove the top plug [D] with the rebound damping adjuster rod from the piston rod.

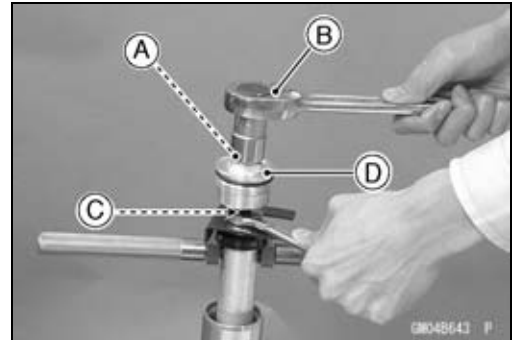

- Remove:
  - Damper [A]
  - Spacer [B]
  - Spring Joint [C]
  - Fork Spring [D]

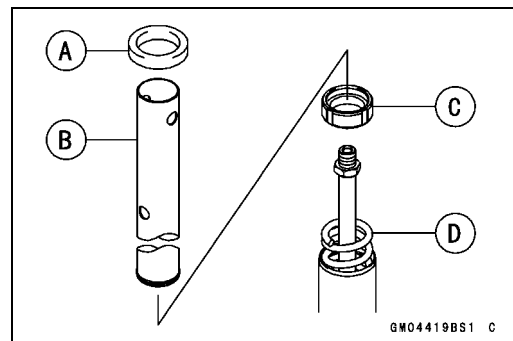

- Drain the fork oil into a suitable container.
- Pump the piston rod [B] up and down at least ten times to expel the oil from the fork.

**Special Tool - Fork Piston Rod Puller, M10 x 1.0 [A]: 57001-1298**

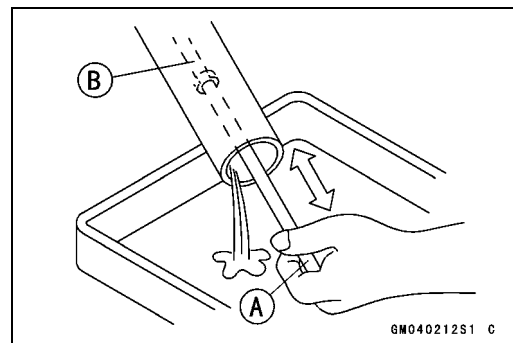

- Hold the fork tube upright, press the inner tube [A] and the piston rod all the way down.
- Pour in the type and amount of fork oil specified.

#### Fork Oil

**Viscosity: SHOWA SS47 or equivalent SAE 10W**

**Amount (per side):**

**When changing oil: approx. 430 mL (14.5 US oz.)**

**After disassembly and completely dry:**

**505 ±2.5 mL (17.1 ±0.085 US oz.)**

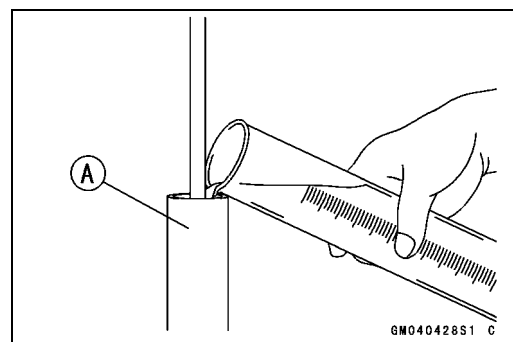

**Front Fork**

- ★ If necessary, measure the oil level as follows.
- Hold the inner tube vertically in a vise.
- Pump the inner tube several times to expel air bubbles.
- Using the piston rod puller [A], move the piston rod [B] up and down more than ten times in order to expel all the air from the fork oil.

**Special Tool - Fork Piston Rod Puller, M10 x 1.0: 57001-1298**

- Remove the piston rod puller.
- Wait until the oil level settles.
- With the fork fully compressed and the piston rod fully pushed in, insert a tape measure or rod into the inner tube, and measure the distance from the top of the outer tube to the oil.

**Oil Level (fully compressed, without spring)**

**Standard: 97 ±2 mm (3.8 ±0.08 in.)**

**(from the top of the outer tube)**

**NOTE**

- Fork oil level may also be measured using the fork oil level gauge.

**Special Tool - Fork Oil Level Gauge [A]: 57001-1290**

- With the fork fully compressed and without fork spring, insert the gauge tube into the inner tube [B] and position the stopper across the top end [F] of the outer tube [C].
- Set the gauge stopper [D] so that its lower side shows the oil level distance specified [E].
- Pull the handle slowly to pump out the excess oil until the oil no longer comes out.
- ★ If no oil is pumped out, there is insufficient oil in the inner tube. Pour in enough oil, then pump out the excess oil as shown above.

- Screw on the rod nut [A] fully to the piston rod [B].

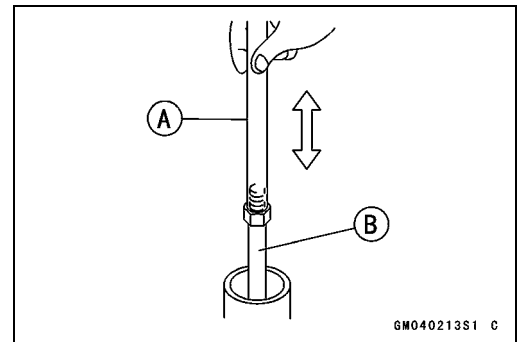

GM040213S1 C

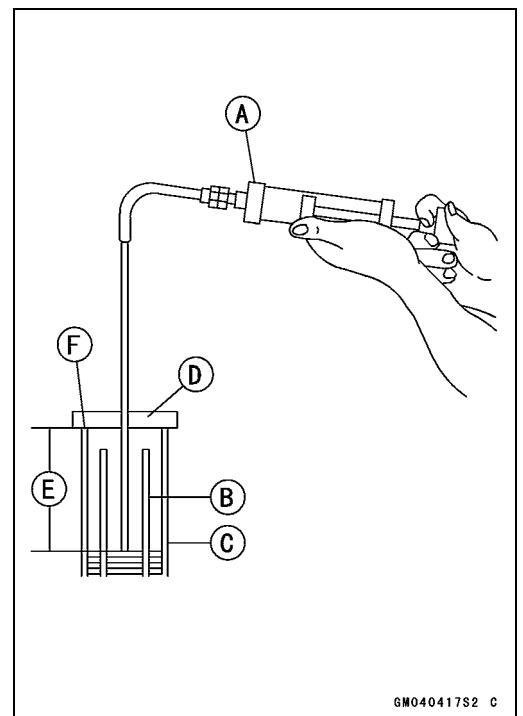

GM040417S2 C

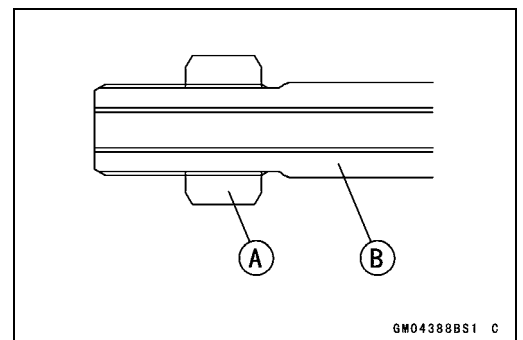

GM04388BS1 C

## 13-14 SUSPENSION

### Front Fork

- Screw the fork piston rod puller [A] onto the end of the piston rod.

**Special Tool - Fork Piston Rod Puller, M10 x 1.0: 57001-1298**

- Pull the puller upward above the outer tube top.
- Install:
  - Fork Spring [B]
- Assemble the following parts, and install them to the inner tube.
  - Spring Joint [C]
  - Spacer [D]
  - Damper [E]

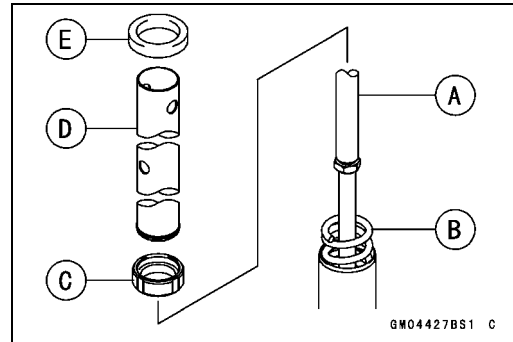

- Set the distance between the upper end [A] of the spring preload adjuster [B] and rebound damping adjuster [C].  
1.5 mm (0.059 in.) [D]

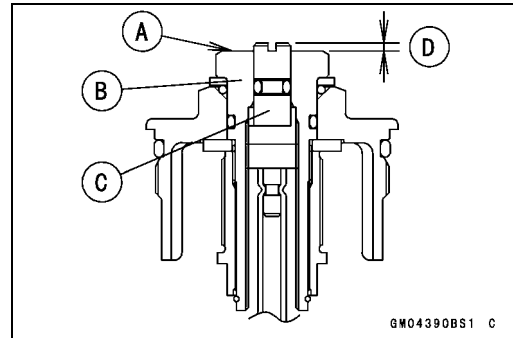

- Set the fork spring compressor on the spacer [A].

**Special Tool - Fork Spring Compressor: 57001-1685**

#### NOTE

○ Set the fork spring compressor so that the end of the handle [B] passes the upper side hole on the spacer by screwing the handle in the holder [C] to the bottom.

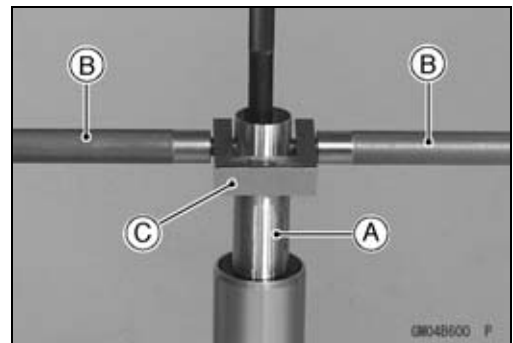

- While holding up the piston rod puller [A] by one person, push down [B] the fork spring compressor, and insert the fork spring stopper [C] between the piston rod nut [D] and the spacer [E].

**Special Tool - Fork Piston Rod Puller, M10 x 1.0: 57001-1298**

**Fork Spring Stopper: 57001-1374**

- Remove the piston rod puller.

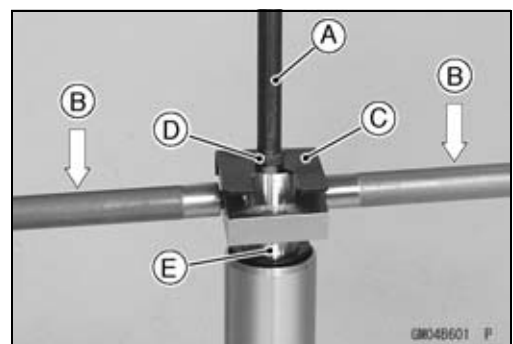



## Front Fork

- Replace O-ring on the top plug with a new one.
- Apply grease to the O-ring.
- Insert the rebound damping adjuster rod [A] into the holes of the piston rod.
- Screw in the top plug [B] stopped onto the piston rod.

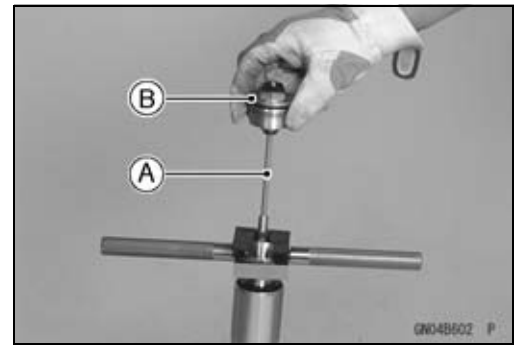

- Holding the spring preload adjuster [A] with a wrench [B], tighten the piston rod nut [C].

**Torque - Piston Rod Nuts: 20 N·m (2.0 kgf·m, 15 ft·lb)**

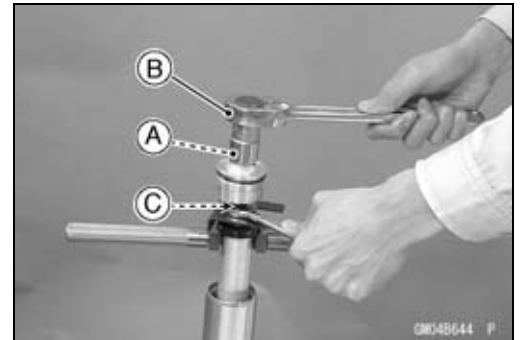

- While holding up the top plug [A] by one person, push down [B] the fork spring compressor, and pull out the fork spring stopper [C].
- Remove the fork spring compressor.
- Rise the outer tube and screw the top plug into it.
- Install the front fork (see Front Fork Installation).

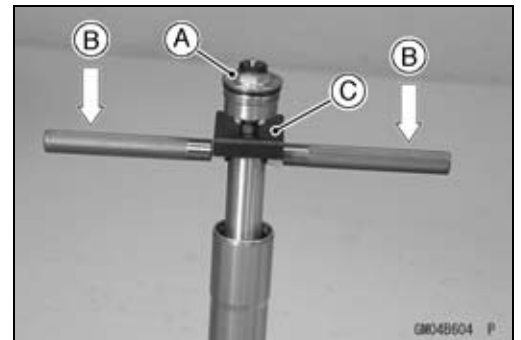

### Front Fork Disassembly

- Remove the front fork (see Front Fork Removal).
- Drain the fork oil (see Fork Oil Change).
- Hold the fork leg with a vise [A].
- Unscrew the Allen bolt [B], then take the bolt and gasket out of the bottom of the inner tube.

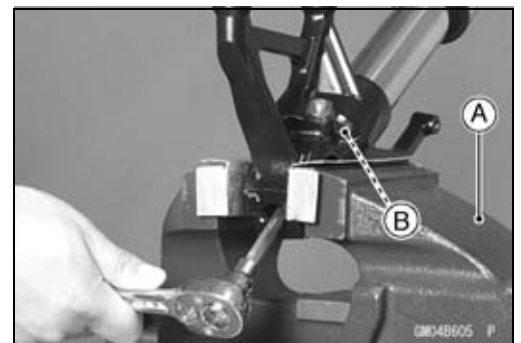

- Take the cylinder unit [A].
- Do not disassemble the cylinder unit.

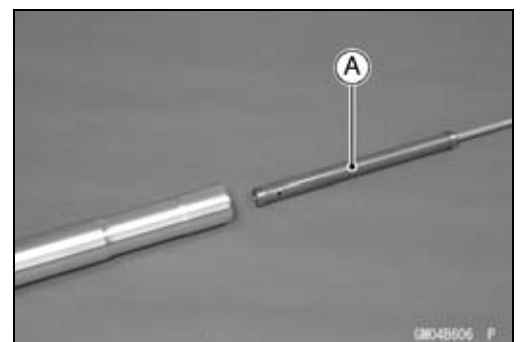

## 13-16 SUSPENSION

### Front Fork

- Separate the inner tube from the outer tube as follows.
- Slide up the dust seal [A].
- Remove the retaining ring [B] from the outer tube.

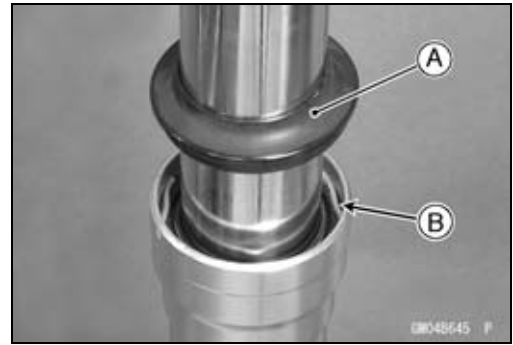

- Holding the inner tube [A] by hand, pull the outer tube [B] several times to pull out the outer tube.

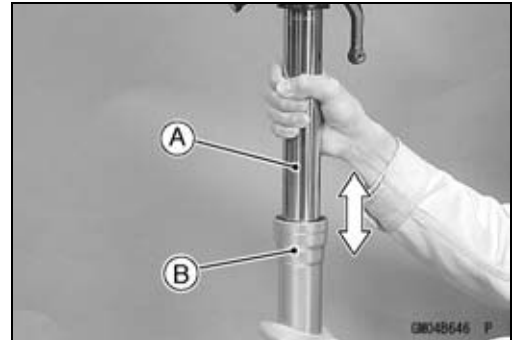

- Remove the inner tube guide bushing [A], outer tube guide bushing [B], washer [C], oil seal [D] from the inner tube.

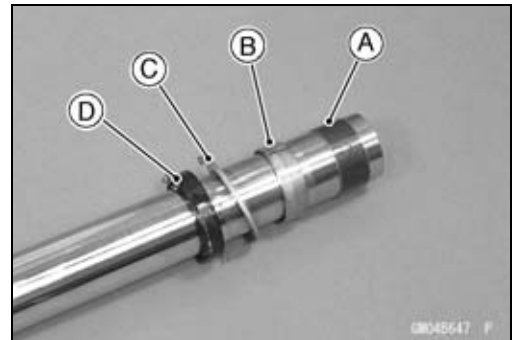

### Front Fork Assembly

- Replace the following parts with new one.
  - Oil Seal [A]
  - Outer Tube Guide Bushing [B]
  - Inner Tube Guide Bushing [C]
  - Bottom Allen Bolt Gasket [D]
  - Dust Seal [E]
  - Retaining Ring [F]
- Install the following parts onto the inner tube.
  - Dust Seal
  - Retaining Ring
  - Oil Seal
  - Washer [G]
  - Outer Tube Guide Bushing
  - Inner Tube Guide Bushing

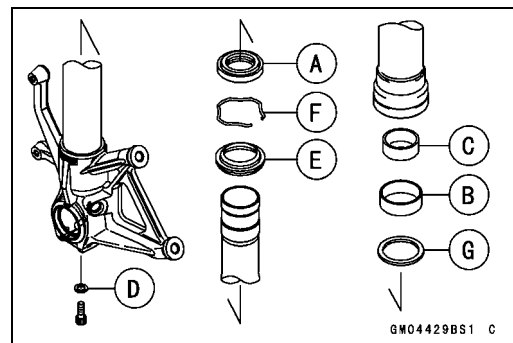

## Front Fork

- Insert the inner tube to the outer tube.
- Fit the new outer tube guide bushing [A] into the outer tube.

### NOTE

○ When assembling the new outer tube guide bushing, hold the washer [B] against the new outer tube guide bushing and tap the washer with the fork oil seal driver [C] until it stops.

**Special Tool - Fork Oil Seal Driver,  $\phi$ 41: 57001-1288**

- Install the oil seal [A].
- Special Tool - Fork Oil Seal Driver,  $\phi$ 41 [B]: 57001-1288**
- Install the retaining ring and dust seal into the outer tube.

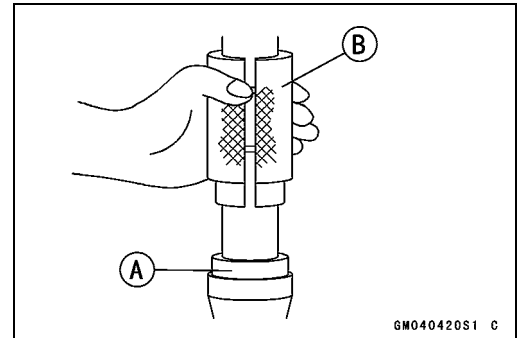
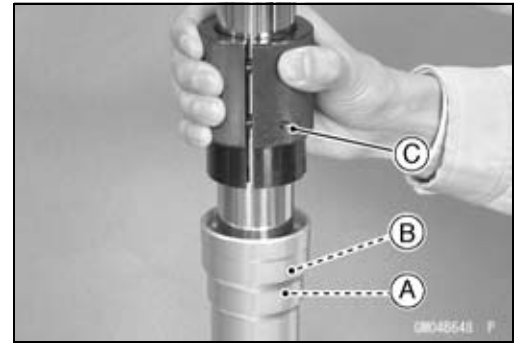

- Insert the cylinder unit [A] into the inner tube [B].
- Hold the front fork in a vise.
- Tighten:
  - Torque - Front Fork Bottom Allen Bolt: 35 N·m (3.5 kgf·m, 26 ft·lb)**
- Pour in the specified type of the fork oil (see Fork Oil Change).

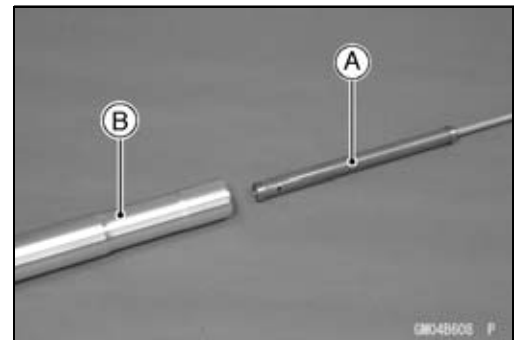

### Inner Tube Inspection

- Visually inspect the inner tube [A], and repair any damage.
- Nicks or rust damage can sometimes be repaired by using a wet-stone to remove sharp edges or raised areas which cause seal damage.
- ★ If the damage is not repairable, replace the inner tube. Since damage to the inner tube damages the oil seal, replace the oil seal whenever the inner tube is repaired or replaced.

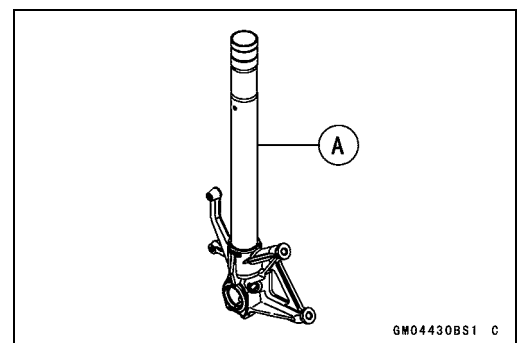

## 13-18 SUSPENSION

### Front Fork

#### CAUTION

If the inner tube is badly bent or creased, replace it. Excessive bending, followed by subsequent straightening, can weaken the inner tube.

- Temporarily assemble the inner and outer tubes, and pump them back and forth manually to check for smooth operation.
- If you feel binding or catching, the inner and outer tubes must be replaced.

#### ⚠ WARNING

A straightened inner or outer fork tube may fall in use, possibly causing an accident. Replace a badly bent or damaged inner or outer tube and inspect the other tube carefully before reusing it.

#### *Dust Seal Inspection*

- Inspect the dust seals [A] for any signs of deterioration or damage.
- ★ Replace it if necessary.

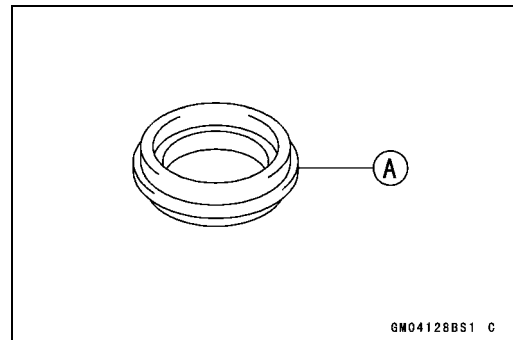

#### *Spring Tension*

- Since a spring becomes shorter as it weakens, check its free length [A] to determine its condition.
- ★ If the spring of either fork leg is shorter than the service limit, it must be replaced. If the length of a replacement spring and that of the remaining spring vary greatly, the remaining spring should also be replaced in order to keep the fork legs balanced for motorcycle stability.

#### Spring Free Length

Standard: 257 mm (10.1 in.)

Service Limit: 252 mm (9.92 in.)

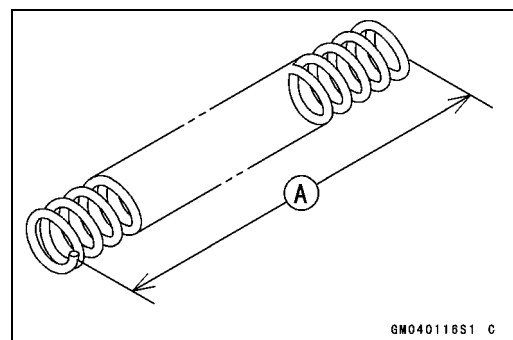

Rear Shock Absorber

**Rebound Damping Force Adjustment**

- To adjust the rebound damping force, turn the lower damping adjuster [A] to the desired position, until you feel a click.
- The standard adjuster setting for an average-build rider of 68 kg (150 lb) with no passenger and no accessories is the **19th click** from the 1st click of the fully clockwise position.

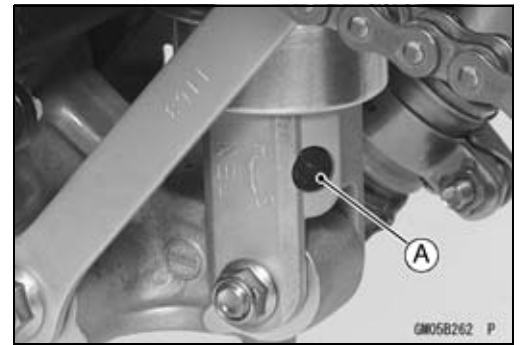

**Rebound Damping Force Adjustment**

Adjuster Position	Damping Force	Setting	Load	Road	Speed
25 Turns out	Weak	Soft	Light	Good	Low
↑	↑	↑	↑	↑	↑
↓	↓	↓	↓	↓	↓
0	Strong	Hard	Heavy	Bad	High

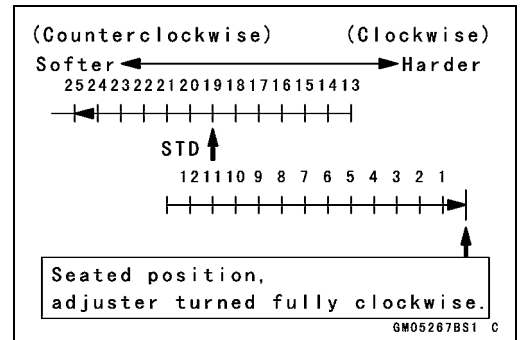

**Compression Damping Force Adjustment**

There are two adjustments you can make to the rear shock absorber gas reservoir.

- High Speed Compression Damping Adjuster [A]
- Low Speed Compression Damping Adjuster [B]

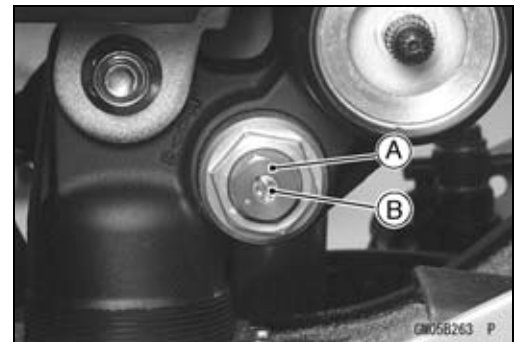

- To adjust the low speed compression damping force, turn the upper damping adjuster with a flat-head screwdriver to the desired position until you feel a click.
- The standard adjuster setting for the average-build rider of 68 kg (150 lb) with no passenger and no accessories is the **2 turns out** from the fully clockwise position.

**NOTE**

○ Adjustment of the rebound damping adjuster for the rear suspension will slightly affect the compression damping force. Always make any damping adjustments in small steps.

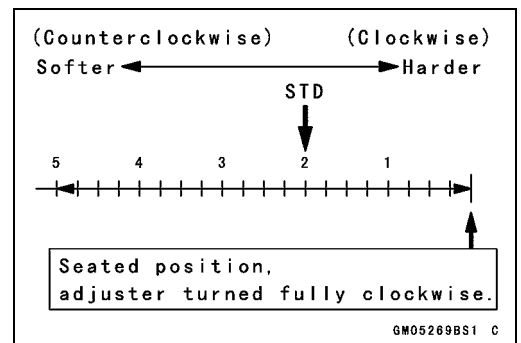

- To adjust the high speed compression damping force, turn the upper damping adjuster with a 14 mm wrench to the desired position until you feel a click.
- The standard adjuster setting for the average-build rider of 68 kg (150 lb) with no passenger and no accessories is the **2 1/2 turns out** from the fully clockwise position.

**NOTE**

○ Adjustment of the rebound damping adjuster for the rear suspension will slightly affect the compression damping force. Always make any damping adjustments in small steps.

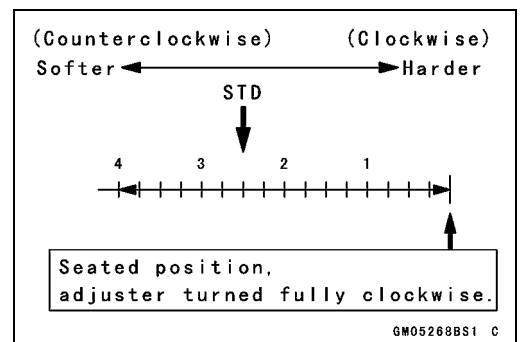

# 13-20 SUSPENSION

## Rear Shock Absorber

### Spring Preload Adjustment

- Loosen the locknut and turn out the adjusting nut to free the spring.

**Special Tool - Hook Wrench T=3.2 R37: 57001-1539**

- To adjust the spring preload, turn in the adjusting nut [A] to the desired position and tighten the locknut [B].  
Spring Length [C]

### Spring Preload Setting

**Standard: Spring length 180 mm (7.09 in.)**

**Usable Range: Spring length 175 ~ 185 mm (6.89 ~ 7.28 in.)**

- The standard adjusting nut setting for an average-build rider of 68 kg (150 lb) with no passenger and no accessories is 180 mm (7.09 in.) spring length.

- Remove the bolts [A] and left foot guard [B] for turning the hook wrench easily.

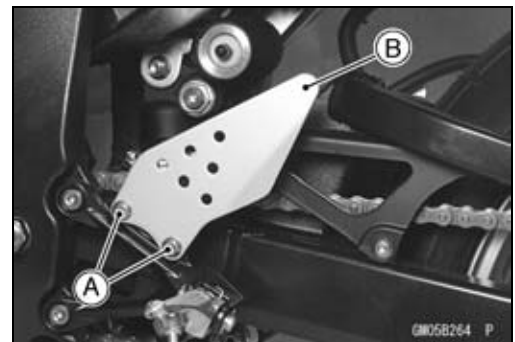
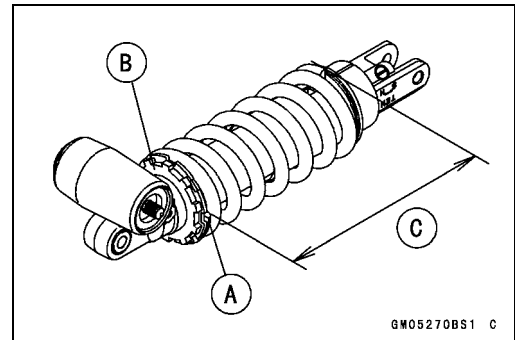

- To adjust the spring preload, turn in the adjusting nut to the desired position and tighten the locknut by using hook wrenches [A] with the rear shock absorber attached the frame.

**Special Tools - Hook Wrench T=3.2 R37: 57001-1539**

- ★ If the spring action feels too soft or too stiff, adjust it.

### Spring Adjustment

Adjuster Position	Damping Force	Setting	Load	Road	Speed
185 mm (7.28 in.)	Weak	Soft	Light	Good	Low
↑	↑	↑	↑	↑	↑
↓	↓	↓	↓	↓	↓
175 mm (6.89 in.)	Strong	Hard	Heavy	Bad	High

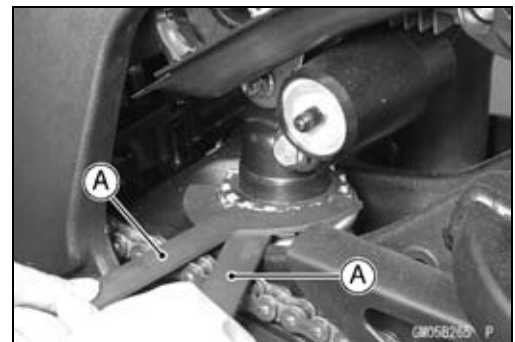

## Rear Shock Absorber

### Rear Shock Absorber Removal

- Remove:
  - Lower Fairings (see Lower Fairings Removal in the Frame chapter)
  - Front Exhaust Pipe (see Front Exhaust Removal in the Engine Top End chapter)
- Using the jack, raise the rear wheel off the ground.
  - Special Tools - Jack: 57001-1238**
  - Jack Attachment: 57001-1608**
- Squeeze the brake lever slowly and it with a band [A].

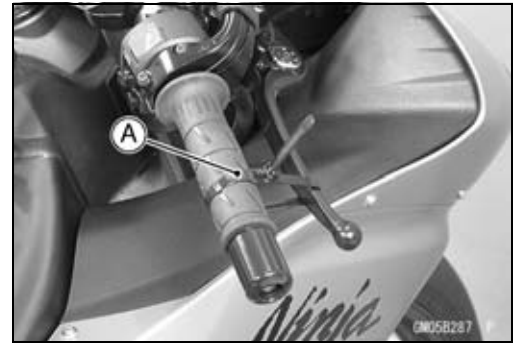

### **⚠ WARNING**

**Be sure to hold the front brake when removing the shock absorber, or the motorcycle may fall over. It could cause an accident and injury.**

- Remove:
  - Lower Shock Absorber Nut and Bolt [A]
  - Upper Tie-Rod Nut and Bolt [B]
  - Upper Shock Absorber Nut and Bolt [C]
- Remove the shock absorber downward.

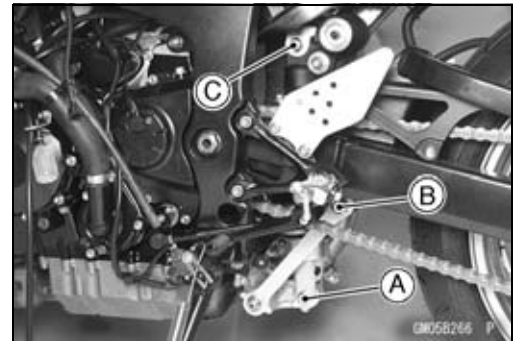

### Rear Shock Absorber Installation

- While lifting up the rear wheel, install the rear shock absorber.
- Tighten:
  - Torque - Rear Shock Absorber Nuts: 34 N·m (3.5 kgf·m, 25 ft·lb)**
  - Tie-Rod Nuts: 59 N·m (6.0 kgf·m, 43 ft·lb)**

### Rear Shock Absorber Inspection

- Remove the rear shock absorber (see Rear Shock Absorber Removal).
- Visually inspect the following items.
  - Smooth Stroke
  - Oil Leakage
  - Crack or Dent
- ★ If there is any damage to the rear shock absorber, replace it.
- Visually inspect the bushing.
- ★ If it show any signs of damage, replace it.

## 13-22 SUSPENSION

### Rear Shock Absorber

#### *Rear Shock Absorber Scrapping*

#### **⚠ WARNING**

Since the reservoir tank of the rear shock absorber contains nitrogen gas, do not incinerate the reservoir tank without first releasing the gas or it may explode.

- Remove the valve cap [A] and release the nitrogen gas completely from the gas reservoir.
- Remove the valve [B].

#### **⚠ WARNING**

Since the high pressure gas is dangerous, do not point the valve toward your face or body.

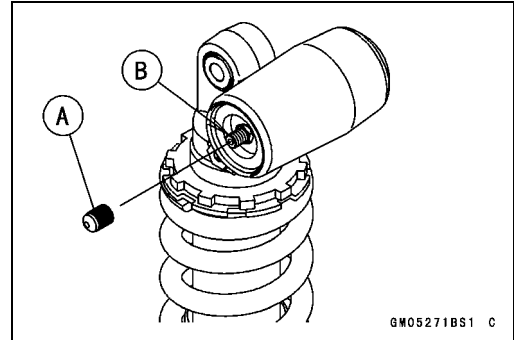



## Swingarm

### Swingarm Removal

● Remove:

- Rear Wheel (see Rear Wheel Removal in the Wheels/Tires chapter)
- Engine Sprocket Cover (see Engine Sprocket Removal in the Final Drive chapter)
- Bolt [A]
- Brake Hose Clamp [B]
- Brake Pedal (see Brake Pedal Removal in the Brakes chapter)
- Rear Exhaust Pipe (see Rear Exhaust Pipe Removal in the Engine Top End chapter)
- Drive Chain (see Drive Chain Removal in the Final Drive chapter)

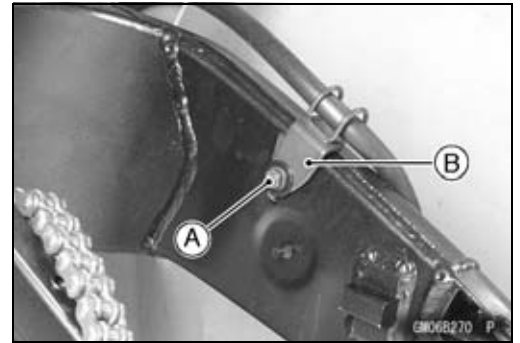

● Remove:

- Upper Tie-Rod Nut and Bolt [A]
- Rear Shock Absorber [B] (see Rear Shock Absorber Removal)



● Unscrew the swingarm pivot shaft locknut [A].

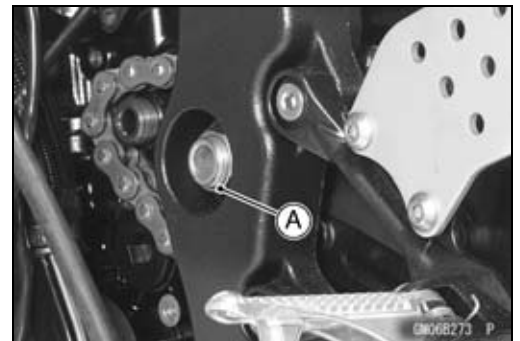

● Unscrew the swingarm pivot collar locknut [A] using the nut wrench [B].

**Special Tool - Swingarm Pivot Nut Wrench: 57001-1597**

- Unscrew the swingarm pivot shaft [C] few times.
- Turn out the swingarm pivot adjusting collar [D].
- Pull out the pivot shaft right side of the motorcycle and remove the swingarm.

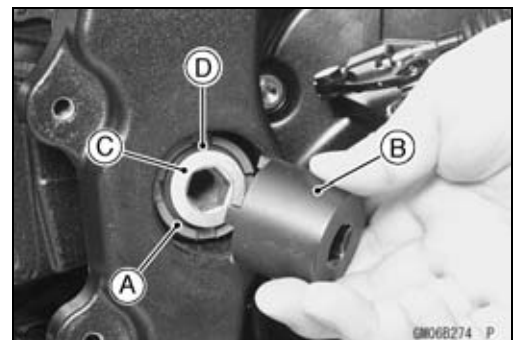

## 13-24 SUSPENSION

### Swingarm

#### Swingarm Installation

- Apply plenty of grease to the lip [A] of the grease seals.

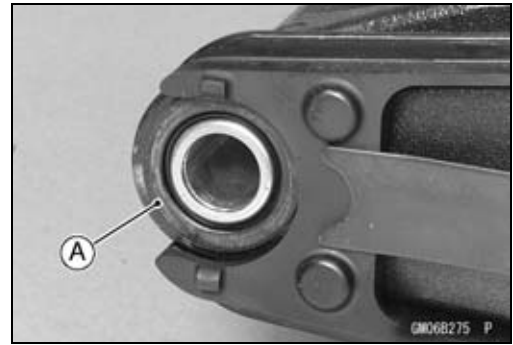

- Screw the adjusting collar [A] into the frame [B] so that the collar does not project the swingarm mating surface [C].

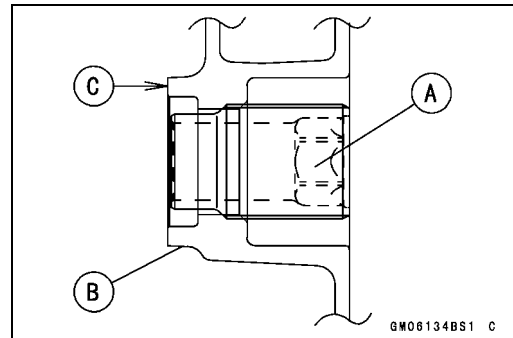

- Place the washer [A] between swingarm left end and frame mating surface.

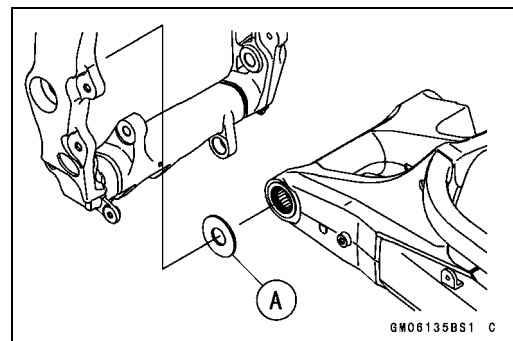

- Insert the pivot shaft [A] into the frame from the right side.
- Tighten the pivot shaft so that the clearance between the adjusting collar [B] and the ball bearing [C] come to 0 mm (0 in.) [D].

**Torque - Swingarm Pivot Adjusting Collar: 20 N·m (2.0 kgf·m, 15 ft·lb)**

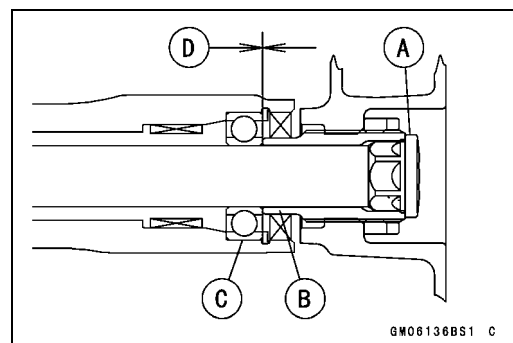

- Tighten the adjusting collar locknut [A] with the swingarm pivot nut wrench [B].

**Special Tool - Swingarm Pivot Nut Wrench: 57001-1597**

**Torque - Swingarm Pivot Adjusting Collar Locknut: 98 N·m (10 kgf·m, 72 ft·lb)**

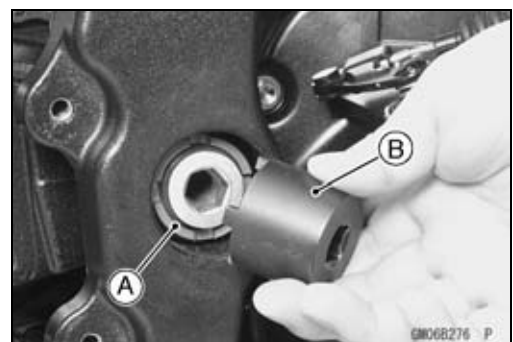

## Swingarm

- Tighten the pivot shaft nut [A].  
**Torque - Swingarm Pivot Shaft Nut: 108 N·m (11 kgf·m, 81 ft·lb)**
- Install the removed parts (see appropriate chapters).

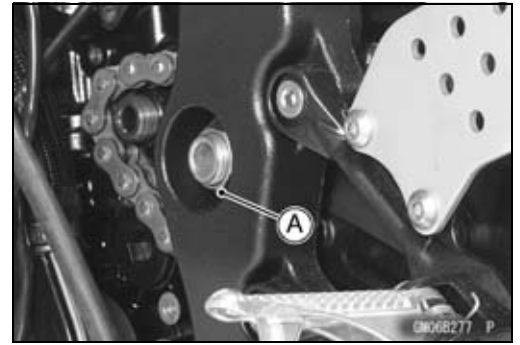

### Swingarm Bearing Removal

- Remove:
  - Swingarm (see Swingarm Removal)
  - Washer [A]
  - Grease Seals [B]
  - Sleeve [C]
  - Circlip [D] (Right Side)

**Special Tool - Inside Circlip Pliers: 57001-143**

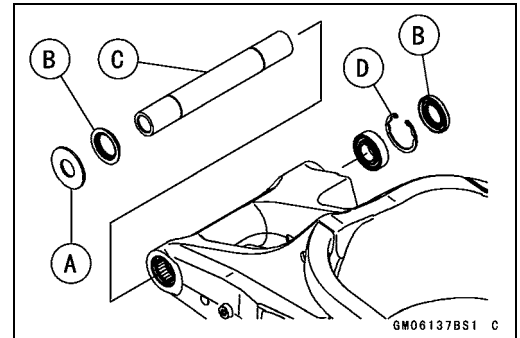

- Remove the ball bearing and needle bearings.  
**Special Tool - Oil Seal & Bearing Remover [A]: 57001-1058**

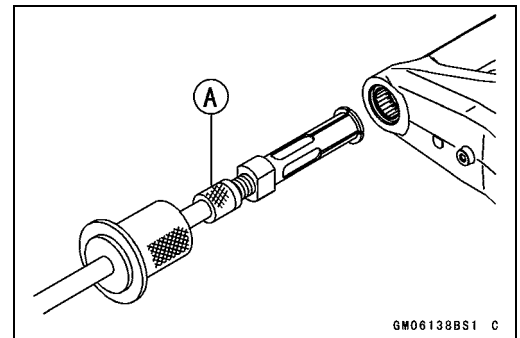

### Swingarm Bearing Installation

- Replace the ball and needle bearings [A] with new ones.
- Install the ball and needle bearings so that the manufacturer's marks face out.

**Special Tools - Bearing Driver Set: 57001-1129**  
**Needle Bearing Driver,  $\phi 28$  [B]: 57001-1610**  
**Spacer,  $\phi 28$ : 57001-1637**

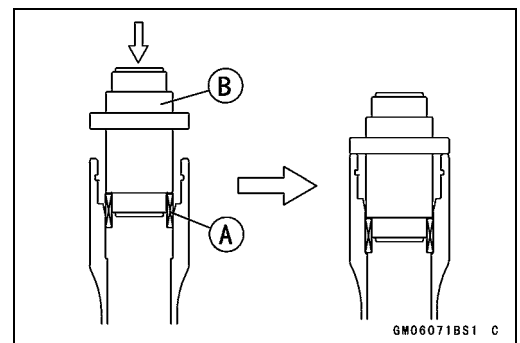

## 13-26 SUSPENSION

### Swingarm

- Install the needle bearings [A], ball bearing [B] and oil seals [C] position as shown.

Circlip [D]

32.5 mm (1.28 in.) [E]

0.5 mm (0.02 in.) [F]

1 mm (0.04 in.) [G]

5 mm (0.20 in.) [H]

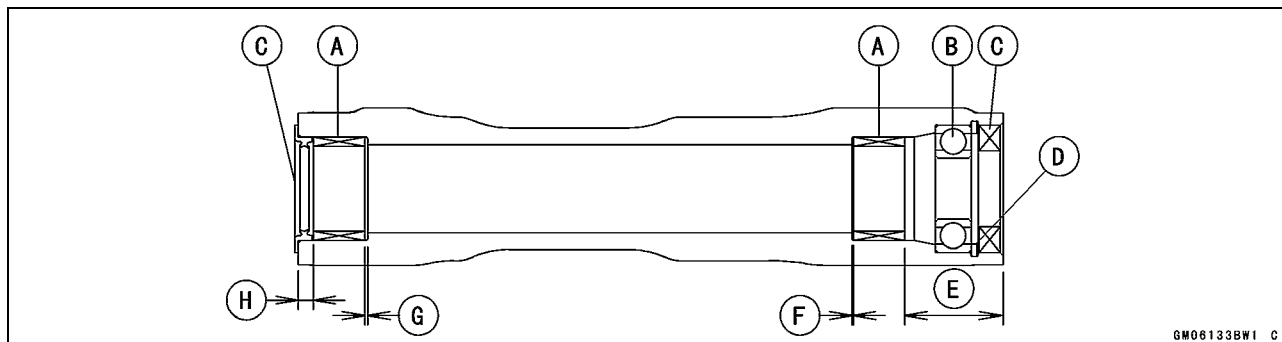

### Swingarm Bearing, Sleeve Inspection

#### CAUTION

**Do not remove the bearings for inspection. Removal may damage them.**

- Inspect the needle bearings [A] and ball bearing installed in the swingarm.
- The rollers and ball in a bearing normally wear very little, and wear is difficult to measure. Instead of measuring, visually inspect the bearing for abrasion, discoloration, or other damage.
- ★ If the needle bearing and sleeve [B] show any signs of abnormal wear, discoloration, or damage, replace them as a set.
- Turn the bearings in the swingarm back and forth [A] while checking for plays, roughness, or binding.
- ★ If bearing play, roughness, or binding is found, replace the bearing.
- Examine the bearing seal on the right side ball bearing for tears or leakage.
- ★ If the seal is torn or is leaking, replace the bearing.

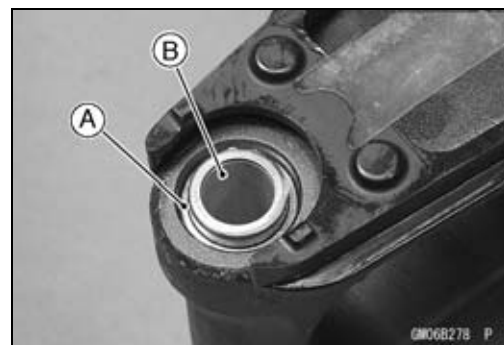

### Chain Guide Inspection

- Refer to the Chain Guide Wear Inspection in the Periodic Maintenance chapter.

## Tie-Rod, Rocker Arm

### Tie-Rod Removal

- Remove:
  - Lower Fairings (see Lower Fairing Removal in the Frame chapter)
  - Front Exhaust Pipe (see Front Exhaust Pipe Removal in the Engine Top End chapter)
- Squeeze the brake lever slowly and hold it with a band [A].

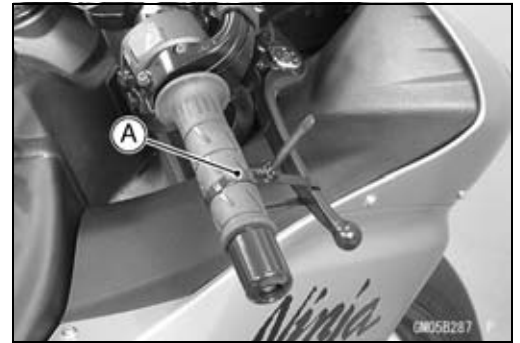

- Using the jack, raise the rear wheel off the ground.

**Special Tools - Jack: 57001-1238**

**Jack Attachment: 57001-1608**

- Remove:
  - Upper Tie-Rod Bolt and Nut [A]
  - Lower Tie-Rod Bolt and Nut [B]
  - Tie-Rods [C]

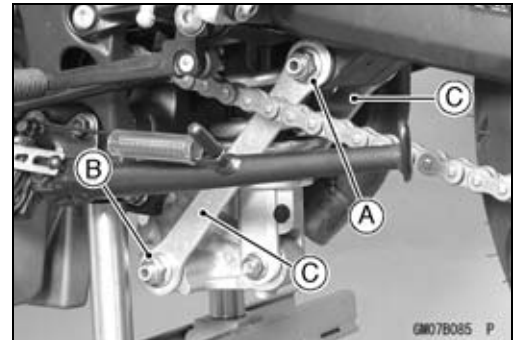

### Tie-Rod Installation

- Apply grease to the inside of the grease seals.
- Install the tie-rods so that the marked side faces [A] outside.
- Tighten:
  - Torque - Tie-Rod Nuts: 59 N·m (6.0 kgf·m, 43 ft·lb)**



### Rocker Arm Removal

- Remove:
  - Lower Fairings (see Lower Fairing Removal in the Frame chapter)
- Squeeze the brake lever slowly and hold it with a band [A].



- Remove:
  - Front Exhaust Pipe (see Front Exhaust Pipe Removal in the Engine Top End chapter)
- Remove the following nuts first.
  - [A] Lower Rear Shock Absorber Nut
  - [B] Lower Tie-Rod Nut
  - [C] Rocker Arm Nut

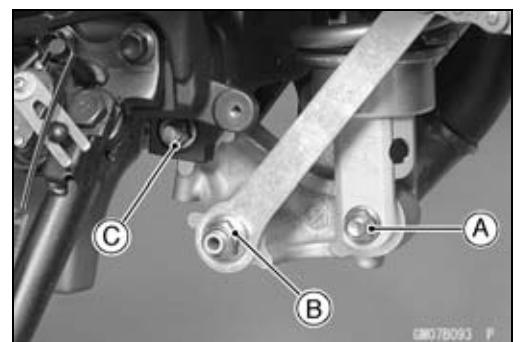

## 13-28 SUSPENSION

### Tie-Rod, Rocker Arm

- Using the jack, raise the rear wheel off the ground.

**Special Tools - Jack [A]: 57001-1238**

**Jack Attachment [B]: 57001-1608**

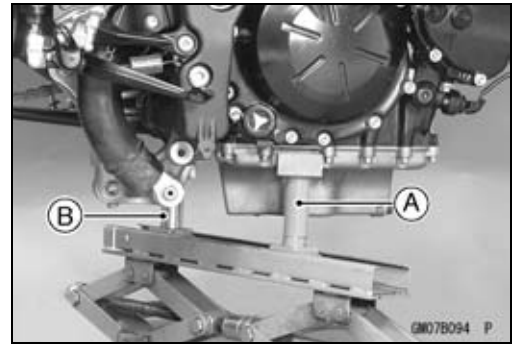

- Remove:

Lower Rear Shock Absorber Bolt [A]

Lower Tie-Rod Bolt [B]

Rocker Arm Bolt [C]

Rocker Arm [D]

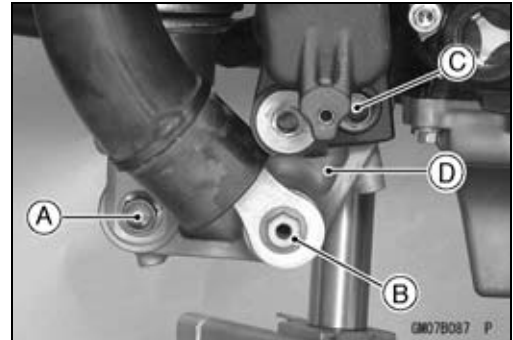

#### ***Rocker Arm Installation***

- Apply grease to the inside of the grease seals.

- Tighten:

**Torque - Uni-Trak Rocker Arm Nut: 34 N·m (3.5 kgf·m, 25 ft·lb)**

**Tie-Rod Nuts: 59 N·m (6.0 kgf·m, 43 ft·lb)**

**Rear Shock Absorber Nut (Lower): 34 N·m (3.5 kgf·m, 25 ft·lb)**

**Tie-Rod, Rocker Arm**

***Tie-Rod and Rocker Arm Bearing Removal***

- Remove:
  - Tie-Rods (see Tie-Rod Removal in this chapter)
  - Rocker Arm (see Rocker Arm Removal in this chapter)
  - Sleeves [A]
  - Grease Seal [B]
  - Swingarm [C]
  - Needle Bearings [D]

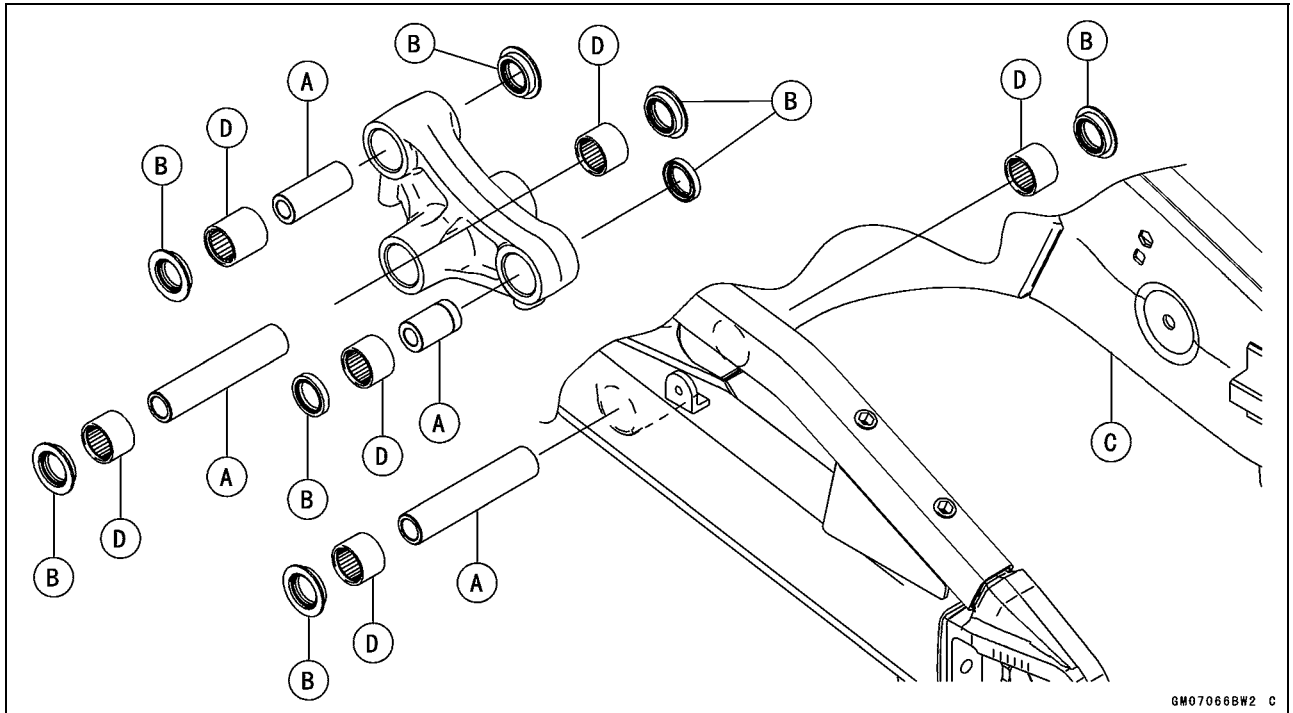

○When remove the needle bearings [A], tap the bearings evenly with the bearing remover shaft [B].

**Special Tool - Bearing Remover Shaft,  $\phi$ 13: 57001-1377**

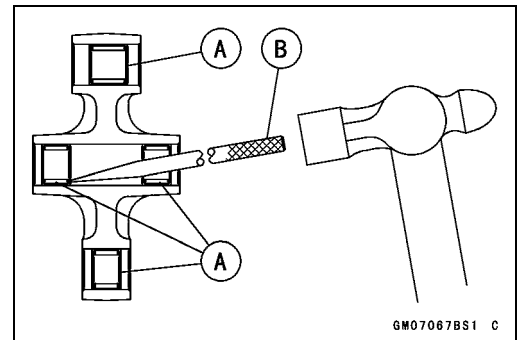

***Tie-Rod and Rocker Arm Bearing Installation***

- Replace the needle bearing and oil seals with new ones.
- Apply plenty of grease to the lips of the oil seals.
- Install the needle bearings and oil seals position as shown.

# 13-30 SUSPENSION

## Tie-Rod, Rocker Arm

- Screw the needle bearing driver [A] into the driver holder [B].
- Insert the needle bearing driver into the needle bearing [C] and press the needle bearing into the housing until the driver contacts the end surface of the housing.  
 Bearing Pressing Depth: 5.5 mm (0.22 in.)[D]  
 5.0 mm (0.20 in.)[E]

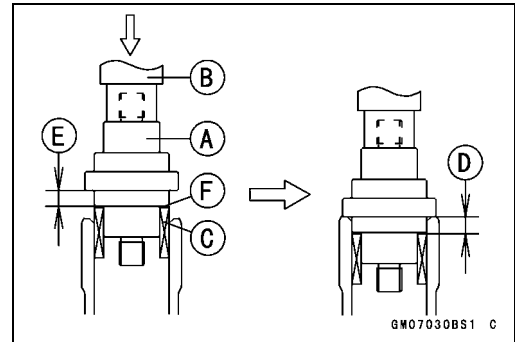

### NOTE

- For a bearing of inner diameter  $\phi 18$ , select the pressing side of the needle bearing driver according to its pressing depth.

**Special Tools - Bearing Driver Set: 57001-1129**  
**Needle Bearing Driver,  $\phi 17/\phi 18$ : 57001-1609**  
**Spacer,  $\phi 18$  [F]: 57001-1636**

### NOTE

- Install the needle bearings so that the marked side faces out.

- Needle Bearing [A]
- Oil Seals [B]
- Front [C]
- Right Side [D]
- Left Side [E]
- Rear Shock Absorber [F]
- Tie-Rods [G]
- Rocker Arm [H]
- 7.5 mm (0.30 in.) [I]
- 5.0 mm (0.20 in.) [J]
- 5.5 mm (0.22 in.) [K]

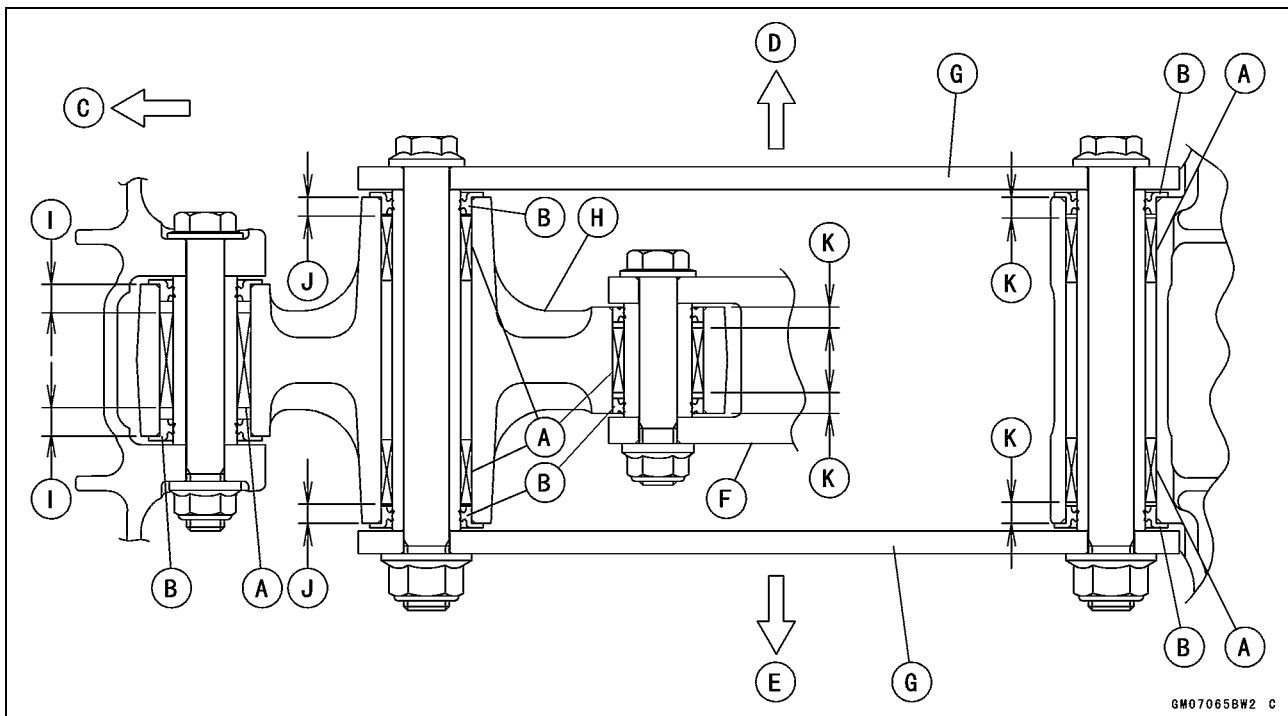



**Tie-Rod, Rocker Arm****Rocker Arm/Tie-Rod Bearing, Sleeve Inspection****CAUTION**

**Do not remove the bearings for inspection. Removal may damage them.**

- Visually inspect the rocker arm, or tie-rod sleeves [A] and needle bearings [B].
- The rollers in a needle bearing normally wear very little, and wear is difficult to measure. Instead of measuring, inspect the bearing for abrasion, color change, or other damage.
- ★ If there is any doubt as to the condition of any of the needle bearings or sleeve replace the sleeve and needle bearings as a set.

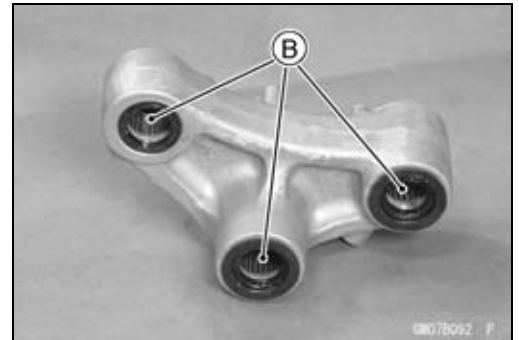
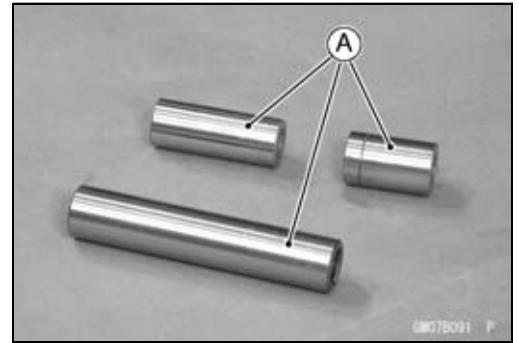
**Rocker Arm/Tie-Rod Bearing Lubrication****NOTE**

○ Since the bearings are packed with grease, lubrication is not required.



---

# Steering

## Table of Contents

Exploded View .....	14-2
Special Tools .....	14-4
Steering .....	14-5
Steering Inspection .....	14-5
Steering Adjustment.....	14-5
Steering Stem.....	14-6
Stem, Stem Bearing Removal.....	14-6
Stem, Stem Bearing Installation.....	14-7
Steering Stem Bearing Lubrication .....	14-9
Steering Stem Warp.....	14-9
Stem Cap Deterioration, Damage.....	14-9
Handlebar .....	14-10
Handlebar Removal .....	14-10
Handlebar Installation .....	14-11

# 14-2 STEERING

## Exploded View

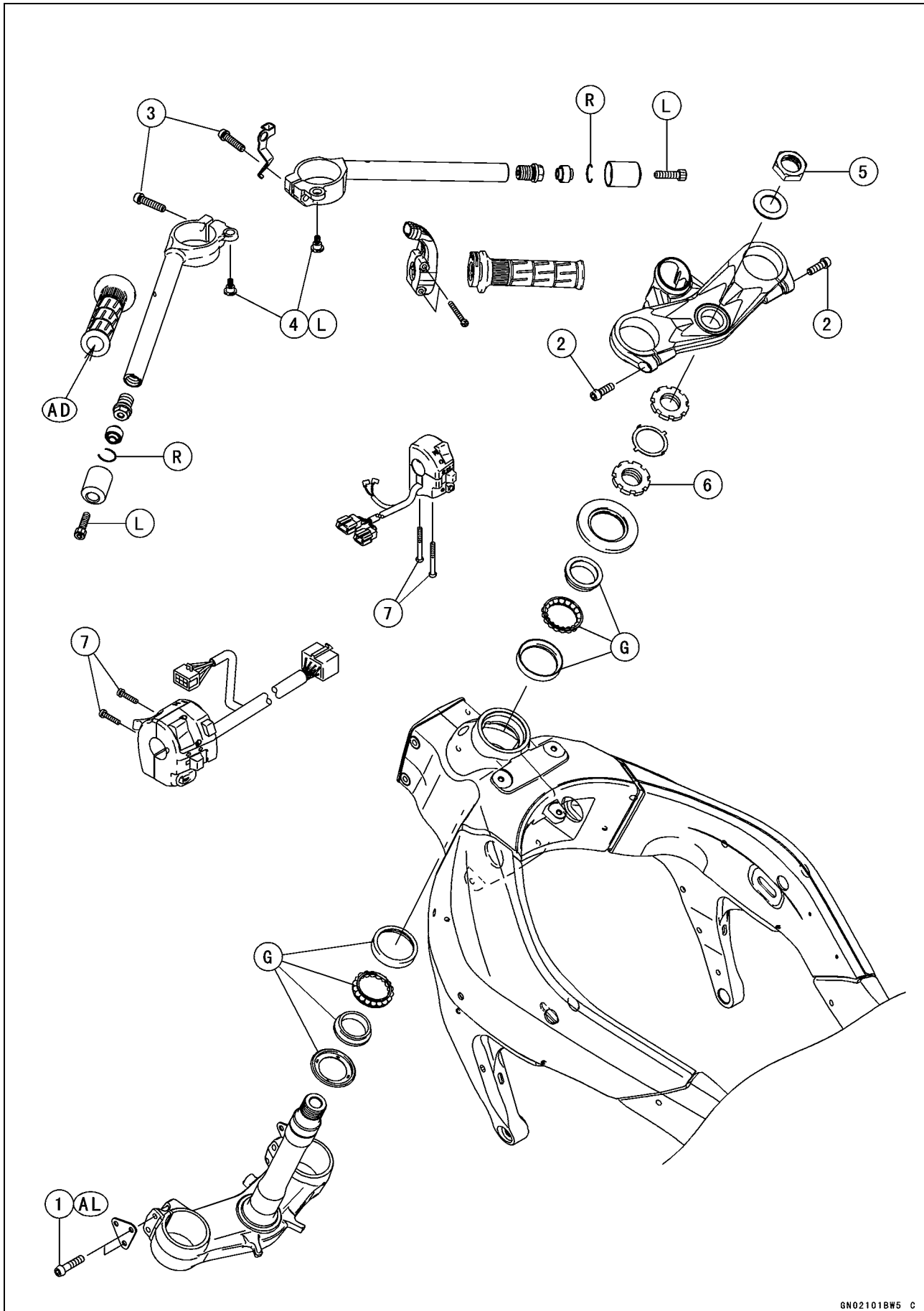

**Exploded View**

No.	Fastener	Torque			Remarks
		N-m	kgf-m	ft-lb	
1	Front Fork Clamp Bolts (Lower)	25	2.5	18	AL
2	Front Fork Clamp Bolts (Upper)	20	2.0	15	
3	Handlebar Bolts	25	2.5	18	
4	Handlebar Position Bolts	9.8	1.0	87 in-lb	L
5	Steering Stem Head Nut	78	8.0	58	
6	Steering Stem Nut	20	2.0	15	
7	Switch Housing Screws	3.5	0.36	31 in-lb	

AD: Apply adhesive.

AL: Tighten the two clamp bolts alternately two times to ensure even tightening torque.

G: Apply grease.

L: Apply a non-permanent locking agent.

R: Replacement Parts

# 14-4 STEERING

## Special Tools

**Bearing Puller:**  
57001-135

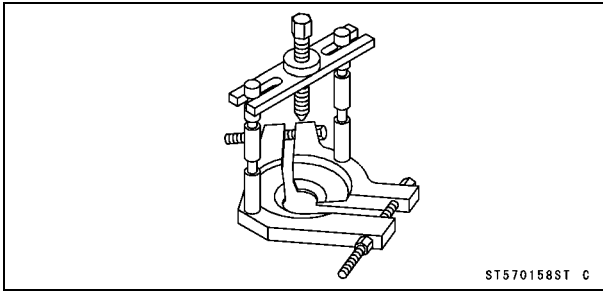

**Bearing Puller Adapter:**  
57001-136

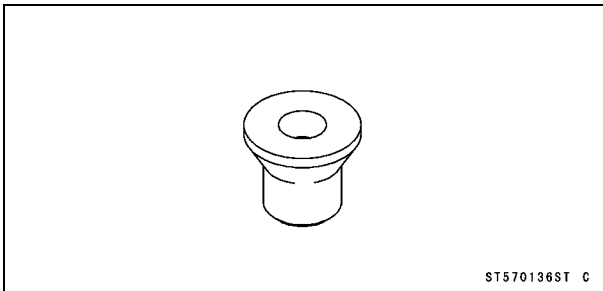

**Head Pipe Outer Race Press Shaft:**  
57001-1075

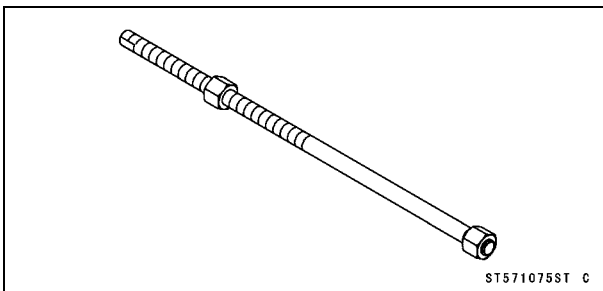

**Steering Stem Nut Wrench:**  
57001-1100

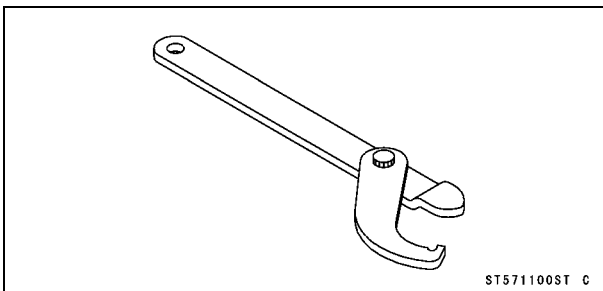

**Bearing Driver Set:**  
57001-1129

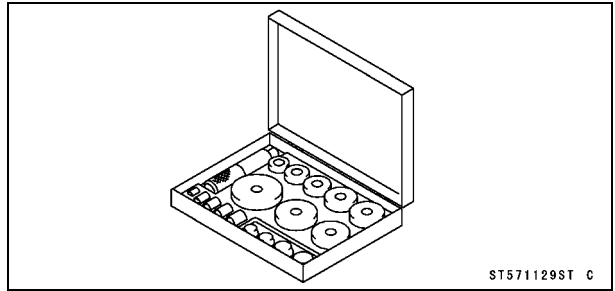

**Steering Stem Bearing Driver,  $\phi 42.5$ :**  
57001-1344

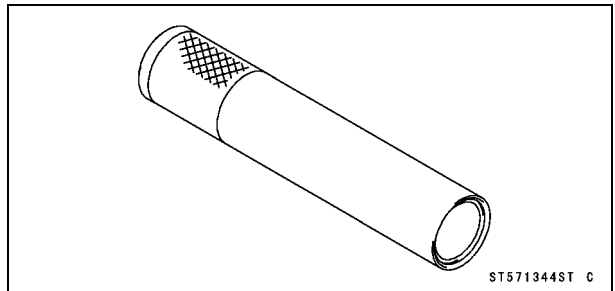

**Steering Stem Bearing Driver Adapter,  $\phi 41.5$ :**  
57001-1345

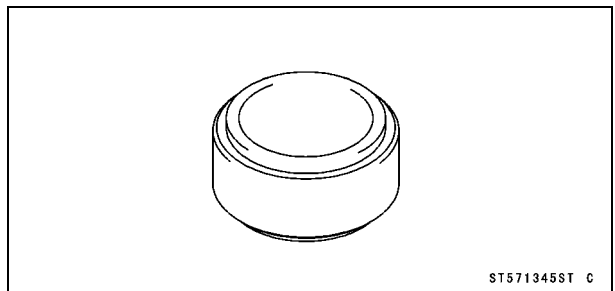

**Head Pipe Outer Race Driver,  $\phi 55$ :**  
57001-1446

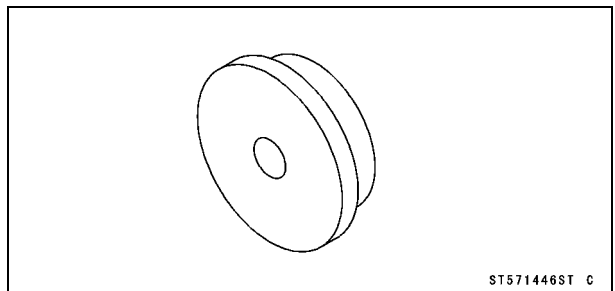

---

## Steering

---

### ***Steering Inspection***

- Refer to the Steering Play Inspection in the Periodic Maintenance chapter.

### ***Steering Adjustment***

- Refer to the Steering Play Adjustment in the Periodic Maintenance chapter.

## 14-6 STEERING

### Steering Stem

#### Stem, Stem Bearing Removal

- Remove:
  - Fuel Tank (see Fuel Tank Removal in the Fuel System (DFI) chapter)
  - Front Wheel (see Front Wheel Removal in the Wheels/Tires chapter)
  - Front Fork (see Front Fork Removal in the Suspension chapter)
  - Brake Hose Clamp Bolt [A]



- Remove:
  - Steering Stem Head Nut [A] and Washer [B]
  - Steering Stem Head
  - Handlebars (see Handlebar Removal)

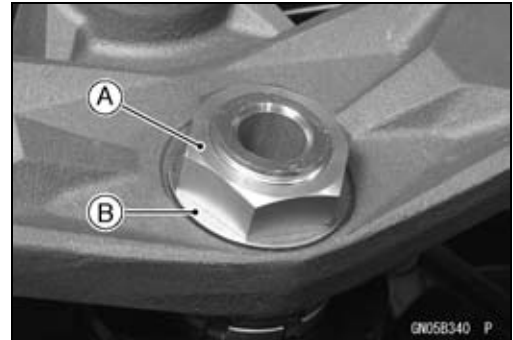

- Bend the claws [A] of lock washer straighten.
- Remove the steering stem locknut [B].
  - Special Tool - Steering Stem Nut Wrench: 57001-1100**
- Remove the lock washer.

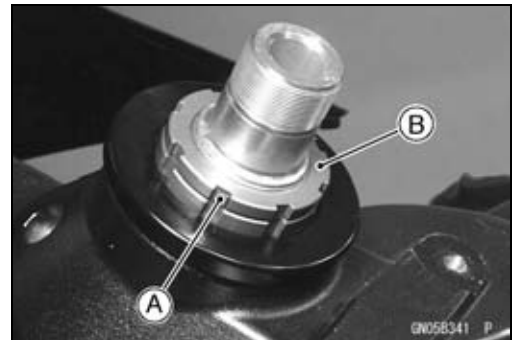

- Pushing up the stem base, and remove the steering stem nut [A] with stem cap.

**Special Tool - Steering Stem Nut Wrench [B]: 57001-1100**

- Remove:
  - Steering Stem [C]
  - Upper Ball Bearing Inner Race

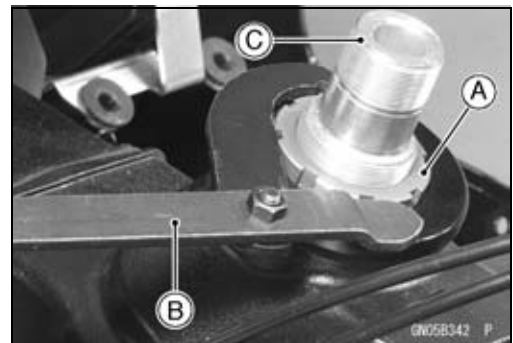

- To remove the bearing outer races [A] pressed into the head pipe [B], insert a bar into the recesses [C] of head pipe, and applying it to both recess alternately hammer it to drive the race out.

#### NOTE

○If either steering stem bearing is damaged, it is recommended that both the upper and lower bearings (including outer races) should be replaced with new ones.

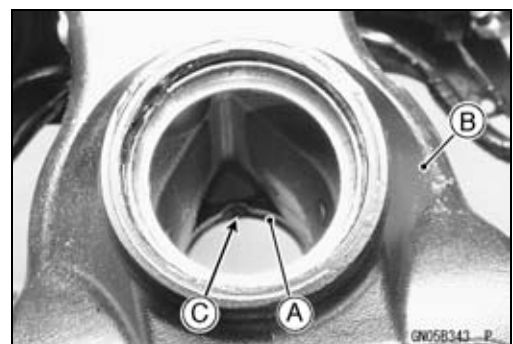



## Steering Stem

- Remove the lower bearing inner race (with its oil seal) [A] which is pressed onto the steering stem [B] with the bearing puller [C] and adapter [D].

**Special Tools - Bearing Puller: 57001-135**

**Bearing Puller Adapter: 57001-136**

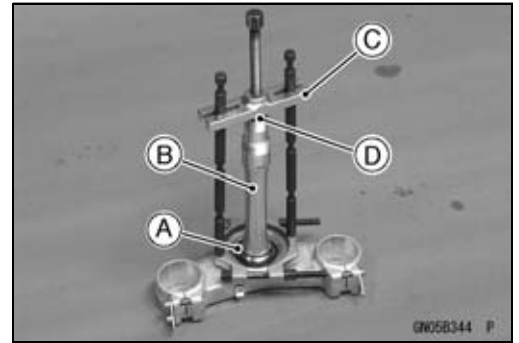

### Stem, Stem Bearing Installation

- Replace the bearing outer races with new ones.
- Drive them into the head pipe at the same time.

**Special Tools - Head Pipe Outer Race Press Shaft [A]: 57001-1075**

**Bearing Driver Set: 57001-1129**

**Head Pipe Outer Race Driver,  $\phi 55$  [B]: 57001-1446**

- Apply grease to the outer races.

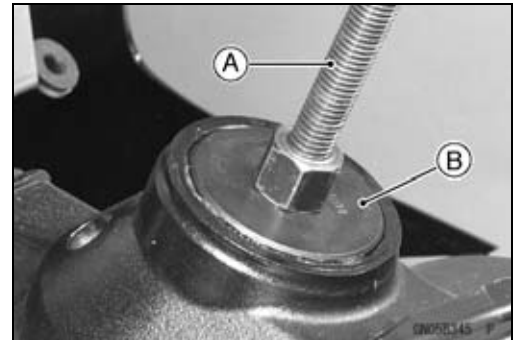

- Replace the bearing inner races and oil seal with new ones.
- Install the oil seal [D] on the steering stem, and drive the lower ball bearing inner race [A] applied the grease onto the stem.

**Special Tools - Steering Stem Bearing Driver,  $\phi 42.5$  [B]: 57001-1344**

**Steering Stem Bearing Driver Adapter,  $\phi 41.5$  [C]: 57001-1345**

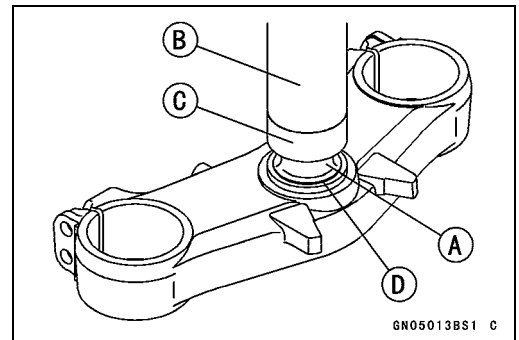

- Install the lower ball bearing [A] onto the stem.
- Apply grease:
  - Inner and Outer Races
  - Lower and Upper Ball Bearings
- The lower and upper ball bearings are identical.

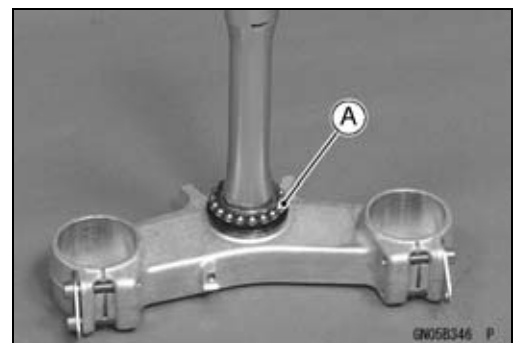

- Install the stem [A] through the head pipe and install the ball bearing [B] and inner race [C] on it.
- Install:
  - Stem Cap [D]
  - Steering Stem Nut [E]

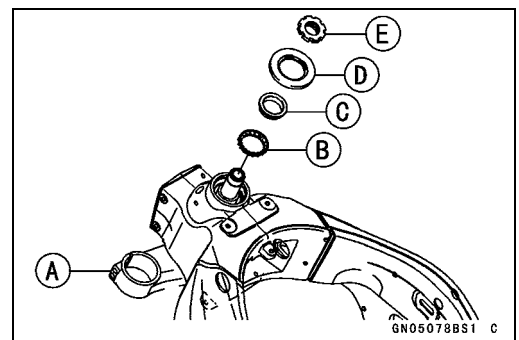

## 14-8 STEERING

### Steering Stem

- Settle the bearings in place as follows.
- Tighten the steering stem nut with **55 N·m (5.6 kgf·m, 41 ft·lb)** of torque first, and loosen it a fraction of a turn until it turns lightly (To tighten the stem nut to the specified torque, hook the wrench on the stem nut, and pull the wrench at the hole by **305 N (31.0 kgf, 69 lb)** [B] force in the direction shown.). Afterward tighten it again with specified torque using a special tool [A].

**Special Tool - Steering Stem Nut Wrench: 57001-1100**

**Torque - Steering Stem Nut: 20 N·m (2.0 kgf·m, 15 ft·lb)**

- For the torque of 20 N·m (2.0 kgf·m, 15 ft·lb), pull the wrench at the hole by 101 N (11.1 kgf, 25 lb) force.
- Install the claw washer [A] so that its bent side [B] faces upward, and engage the bent claws with the grooves of stem locknut [C].
- Hand tighten the stem locknut until it touches the claw washer.
- Tighten the stem locknut clockwise until the claws are aligned with the grooves (ranging from 2nd to 4th) of stem nut [D], and bend the 2 claws downward [E].

- Install the stem head [A] with handlebars to the steering stem [B].
- Install the washer [C], and temporary tighten the stem head nut [D].
- Install the front fork (see Front Fork Installation in the Suspension chapter).

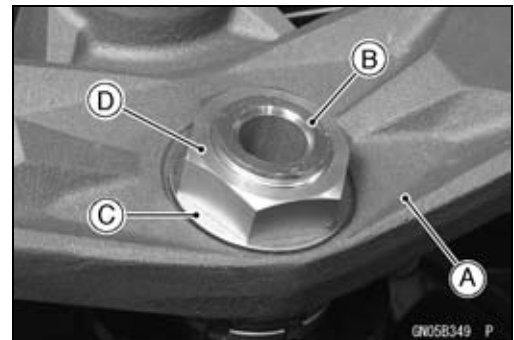
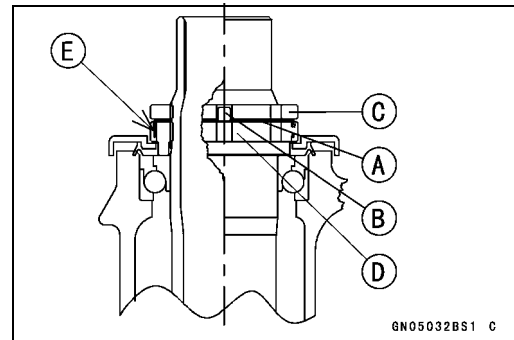
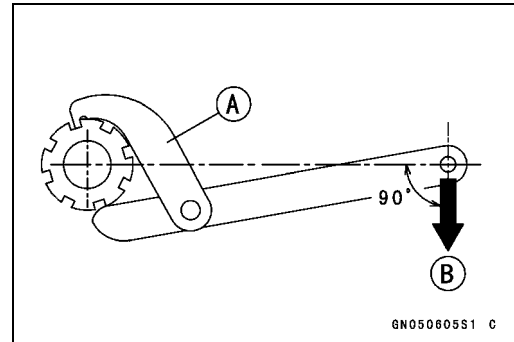

## Steering Stem

### NOTE

- Tighten the upper fork clamp bolts [A] first, next the stem head nut [B], last the lower fork clamp bolts [C] and the handlebar bolts [D].
- Tighten the two lower fork clamp bolts alternately two times to ensure even tightening torque.

**Torque - Front Fork Clamp Bolts (Upper):** 20 N·m (2.0 kgf·m, 15 ft·lb)

**Steering Stem Head Nut:** 78 N·m (8.0 kgf·m, 58 ft·lb)

**Front Fork Clamp Bolts (Lower):** 25 N·m (2.5 kgf·m, 18 ft·lb)

**Handlebar Bolts:** 25 N·m (2.5 kgf·m, 18 ft·lb)

### ⚠ WARNING

Do not impede the handlebar turning by routing the cables, harnesses and hoses improperly (see Cable, Wire, and Hose Routing section in the Appendix chapter).

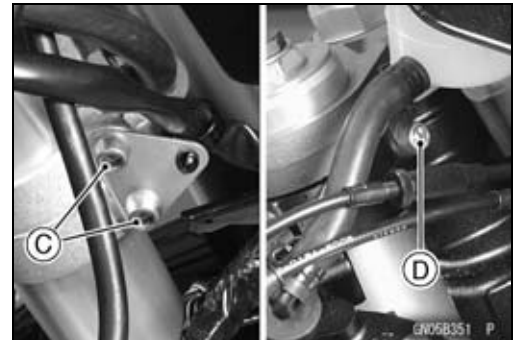
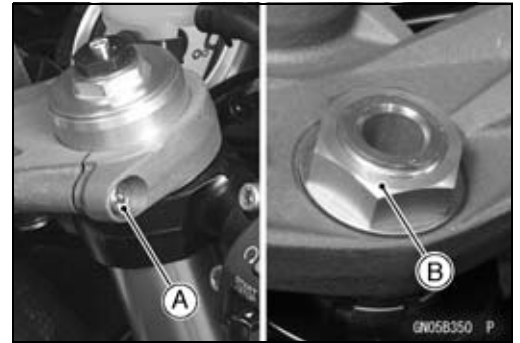

### Steering Stem Bearing Lubrication

- Refer to the Steering Stem Bearing Lubrication in the Periodic Maintenance chapter.

### Steering Stem Warp

- Whenever the steering stem is removed, or if the steering can not be adjusted for smooth action, check the steering stem for straightness.
- ★ If the steering stem [A] is bent, replace the steering stem.

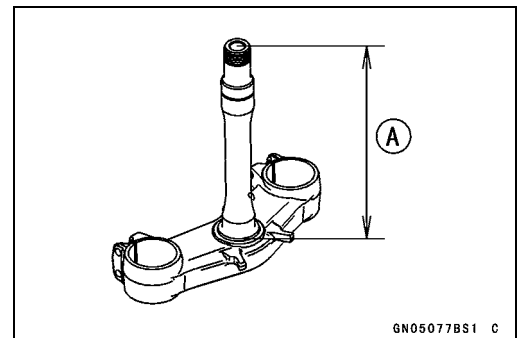

### Stem Cap Deterioration, Damage

- ★ Replace the stem cap if its oil seal [A] shows damage.



## 14-10 STEERING

### Handlebar

#### Handlebar Removal

- Loosen:
  - Front Fork Clamp Bolts [A] (Right and Left)
  - Handlebar Bolts [B] (Right and Left)
  
- Remove:
  - Clutch Lever Clamp Bolts [A]
  - Clutch Lever Assembly [B]
  - Left Switch Housing [C]
  - Handlebar Weight [D]
  
- Remove:
  - Front Brake Master Cylinder [A] (see Front Master Cylinder Removal in the Brakes chapter)
  - Right Switch Housing [B]
  - Throttle Case [C]
  - Handlebar Weight [D]
  - Throttle Grip [E]
  
- Remove:
  - Steering Stem Head Nut [A] and Washer [B]
  - Steering Stem Head [C] with Handlebars
  
- Remove:
  - Handlebar Position Bolts [A]
  - Handlebars [B]
  - Left handlebar grip [C]

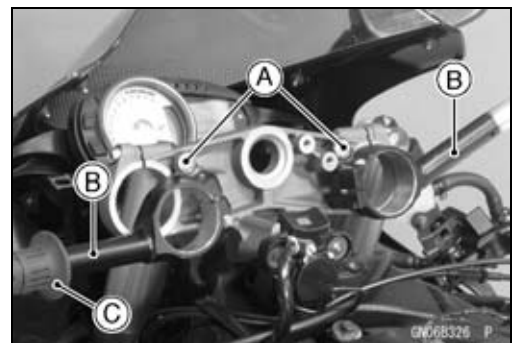
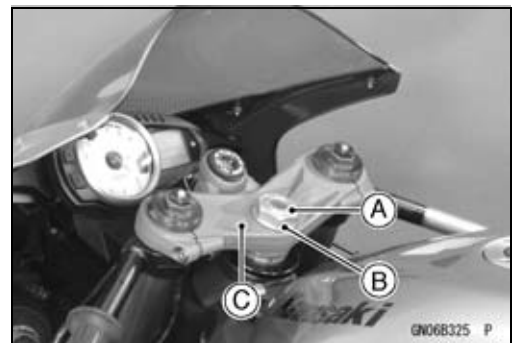
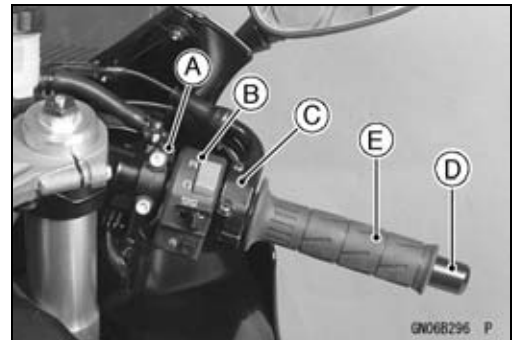
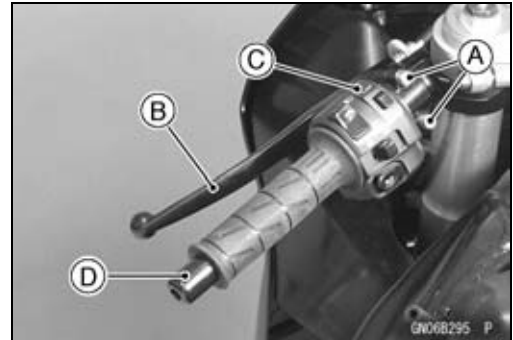
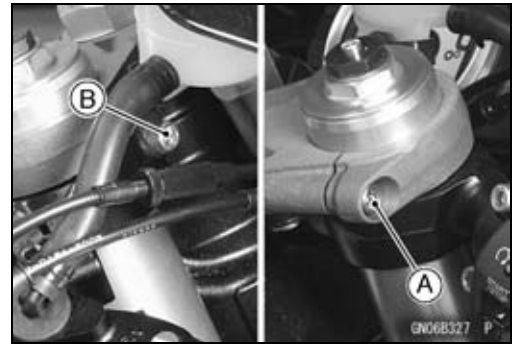

## Handlebar

### ***Handlebar Installation***

- Apply adhesive cement to the inside of the left handlebar grip.
- Apply a non-permanent locking agent to the threads of handlebar position bolts.
- Tighten:

**Torque - Steering Stem Head Nut: 78 N·m (8.0 kgf·m, 58 ft·lb)**

**Handlebar Bolts: 25 N·m (2.5 kgf·m, 18 ft·lb)**

**Handlebar Position Bolts: 9.8 N·m (1.0 kgf·m, 87 in·lb)**

- Install the front brake master cylinder (see Front Master Cylinder Installation in the Brakes chapter).
- Install the left and right switch housings.
- Fit the projection [A] into a small hole [B] in the handlebar.

**Torque - Switch Housing Screws: 3.5 N·m (0.36 kgf·m, 31 in·lb)**

- Install:
  - Clutch Lever (see Clutch Lever Installation in the Clutch chapter)

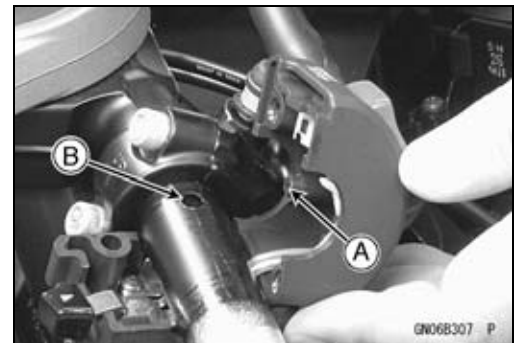

- Install:
  - Throttle Grip
  - Throttle Cable Tips
  - Throttle Cases
- Fit the projection [A] into a small hole [B] in the handlebar.

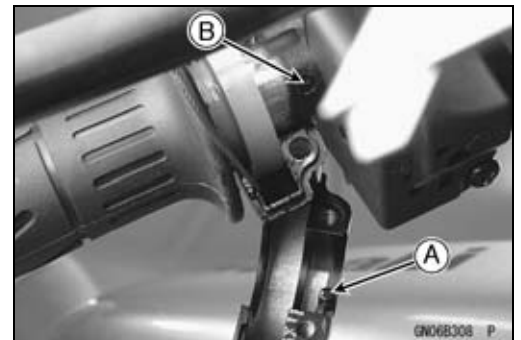

- Apply a non-permanent locking agent to the threads of handlebar weight bolts, and tighten them.
- Install the removed parts (see appropriate chapters).



# Frame

## Table of Contents

Exploded View .....	15-2
Seats .....	15-8
Rear Seat Removal.....	15-8
Rear Seat Installation.....	15-8
Front Seat Removal .....	15-8
Front Seat Installation .....	15-8
Fairings.....	15-9
Lower Fairing Removal .....	15-9
Lower Fairing Installation .....	15-9
Middle Fairing Removal .....	15-9
Windshield Removal .....	15-11
Windshield Installation .....	15-11
Upper Fairing Disassembly.....	15-12
Upper Fairing Assembly.....	15-12
Upper Fairing Installation .....	15-12
Inner Cover Removal .....	15-12
Inner Cover Installation .....	15-13
Center Inner Fairing Removal.....	15-13
Center Inner Fairing Installation.....	15-13
Lower Inner Fairing Removal.....	15-13
Lower Inner Fairing Installation.....	15-14
Side Covers .....	15-15
Left Side Cover Removal .....	15-15
Left Side Cover Installation .....	15-15
Right Side Cover Removal.....	15-15
Right Side Cover Installation.....	15-15
Seat Cover.....	15-16
Seat Cover Removal.....	15-16
Seat Cover Installation.....	15-16
Engine Cover.....	15-17
Heat Insulation Plate Removal.....	15-17
Heat Insulation Plate Installation.....	15-17
Heat Insulation Rubber Plate Removal .....	15-17
Heat Insulation Rubber Plate Installation.....	15-18
Fenders .....	15-19
Front Fender Removal .....	15-19
Front Fender Installation .....	15-19
Flap and Rear Fender Removal.....	15-19
Flap and Rear Fender Installation.....	15-23
Frame .....	15-24
Rear Frame Removal.....	15-24
Rear Frame Installation.....	15-24
Frame Inspection .....	15-24
Sidestand.....	15-25
Sidestand Removal.....	15-25
Sidestand Installation.....	15-25

# 15-2 FRAME

## Exploded View

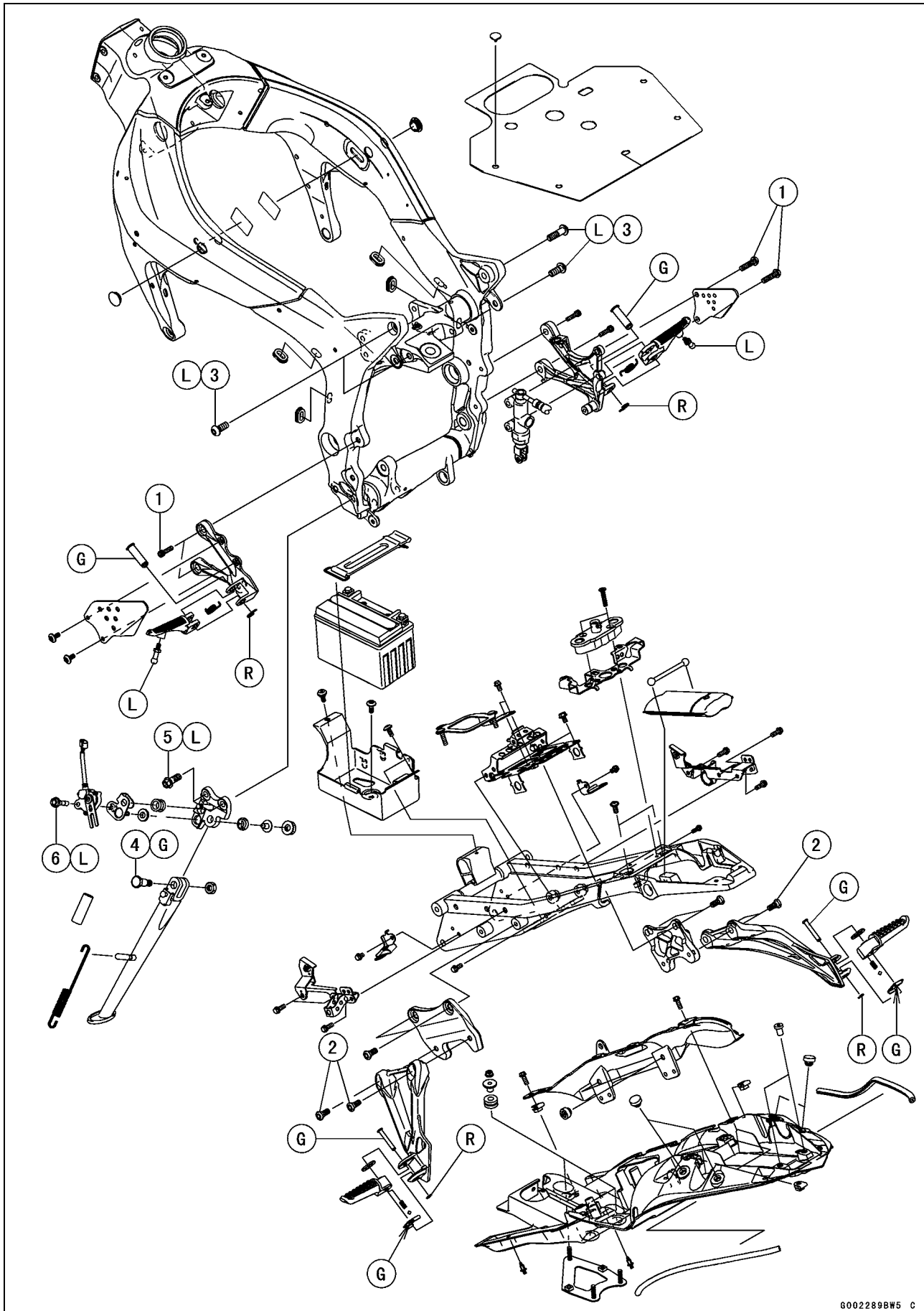



## Exploded View

No.	Fastener	Torque			Remarks
		N·m	kgf·m	ft·lb	
1	Front Footpeg Bracket Bolts	25	2.5	18	
2	Rear Footpeg Bracket Bolts	25	2.5	18	
3	Rear Frame Bolts	44	4.5	32	L
4	Sidestand Bolt	44	4.5	32	G
5	Sidestand Bracket Bolts	49	5.0	36	L
6	Sidestand Switch Bolt	8.8	0.90	78 in·lb	L

G: Apply grease.

L: Apply a non-permanent locking agent.

R: Replacement Parts

# 15-4 FRAME

## Exploded View

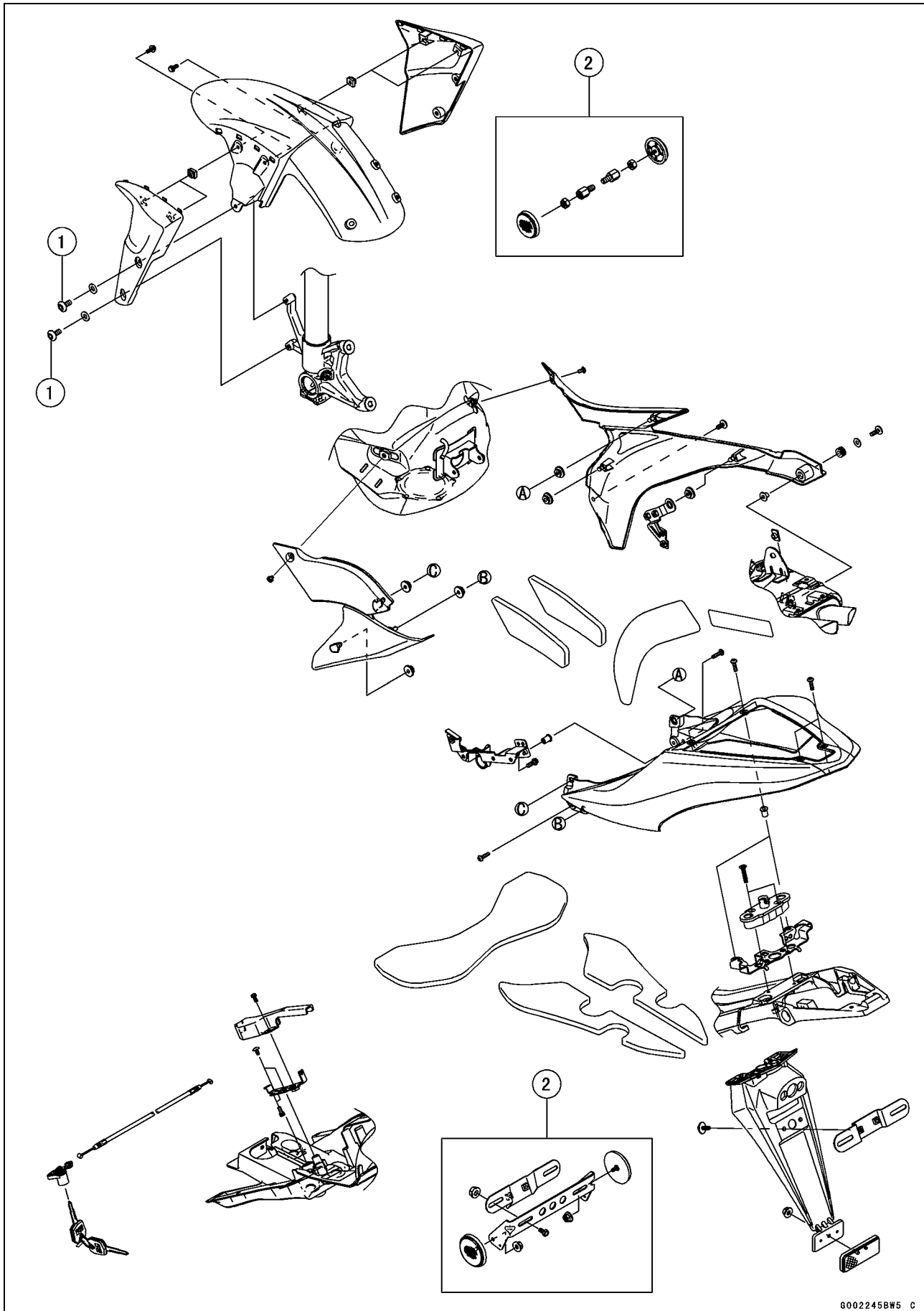

**Exploded View**

<b>No.</b>	<b>Fastener</b>	<b>Torque</b>			<b>Remarks</b>
		<b>N·m</b>	<b>kgf·m</b>	<b>ft·lb</b>	
1	Front Fender Mounting Bolts	3.9	0.40	35 in·lb	

2. United States and Canada Models

# 15-6 FRAME

## Exploded View

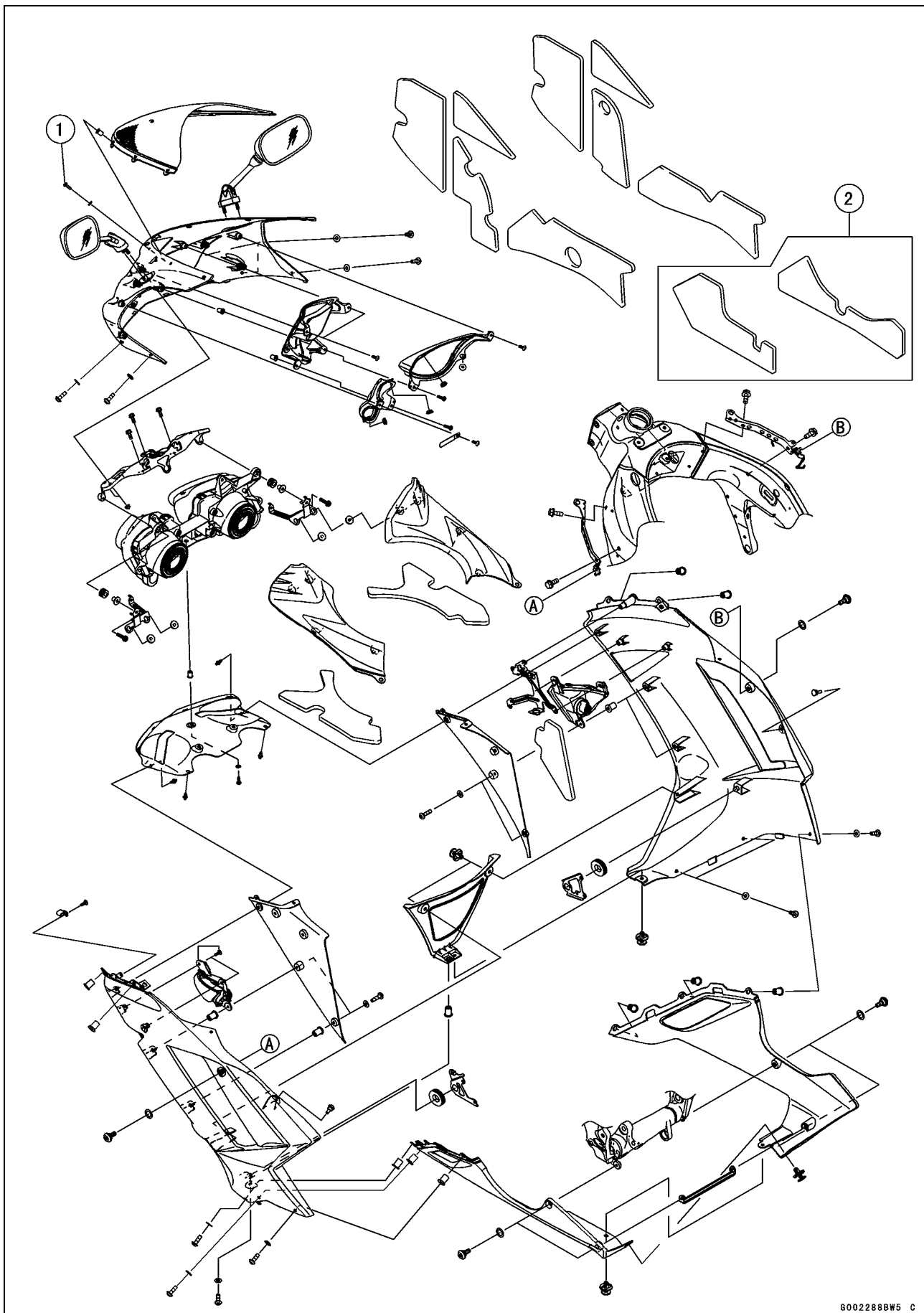

**Exploded View**

<b>No.</b>	<b>Fastener</b>	<b>Torque</b>			<b>Remarks</b>
		<b>N·m</b>	<b>kgf·m</b>	<b>ft·lb</b>	
1	Windshield Mounting Bolts	0.4	0.04	4 in·lb	

2. ZX600P7F

## 15-8 FRAME

### Seats

#### **Rear Seat Removal**

- Insert the ignition switch key [A] into the seat lock, turning the key counterclockwise, pulling the front part of the seat [B] up, and pull the seat forward.

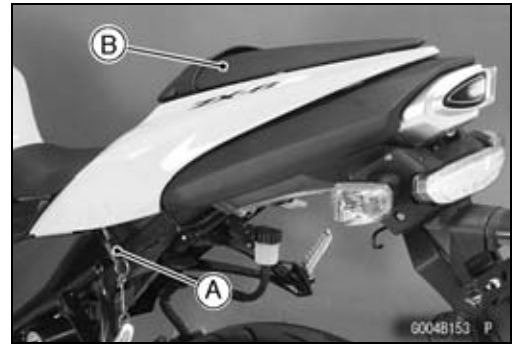

#### **Rear Seat Installation**

- Put the rear seat hook [A] on the rib [B].
- Insert the seat pins [C] into the latch holes [D].

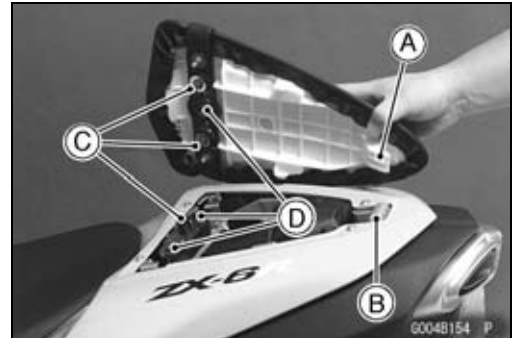

#### **Front Seat Removal**

- Remove:
  - Side Covers (Both Side) (see Right/Left Side Cover Removal)
  - Mounting Bolts [A] (Both Side)
- Remove the front seat [B] by pulling the front of it up and forward.



#### **Front Seat Installation**

- Slip the front seat hooks [A] under the brace [B] of the bracket.
- Tighten the mounting bolts.

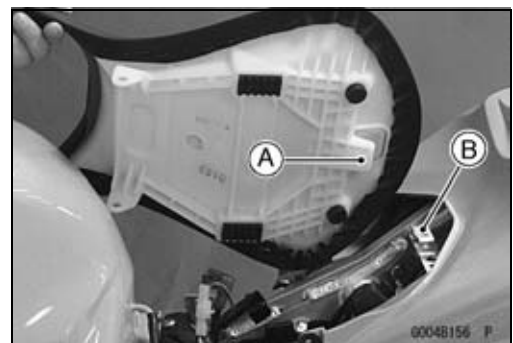

## Fairings

### Lower Fairing Removal

- Remove:
  - Bolts [A] with Washers
- Clear the hook portion from the slot.

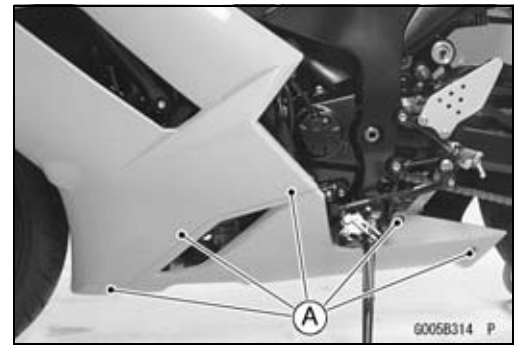

- Pull up the core [A] by the thin blade screw driver.
- Remove:
  - Quick Rivets [B]
- Separate the right lower fairing from the left lower fairing.

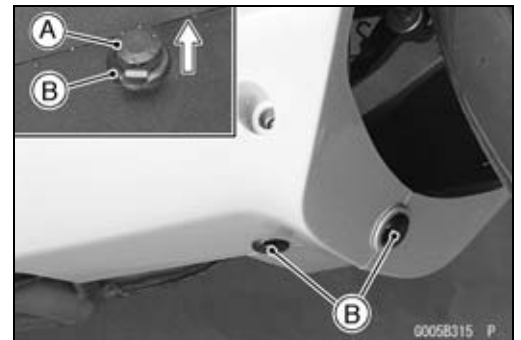

### Lower Fairing Installation

- Set the quick rivet [A] and push the core [B].

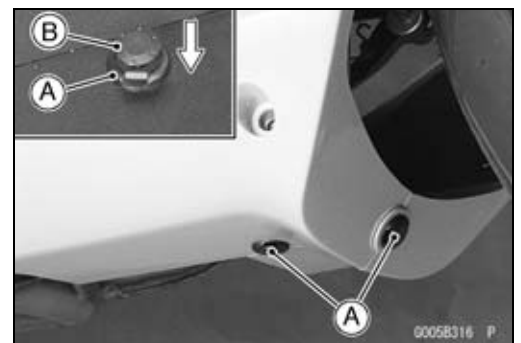

- Insert the hook portion [A] into the slot [B].

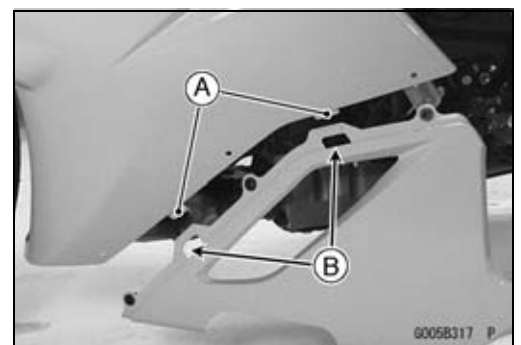

### Middle Fairing Removal

#### Left Middle Fairing Removal

- Remove:
  - Lower Fairings (see Lower Fairing Removal)
  - Bolts [A] with Washers
  - Left Inner Cover [B] (see Right and Left Inner Cover Removal)

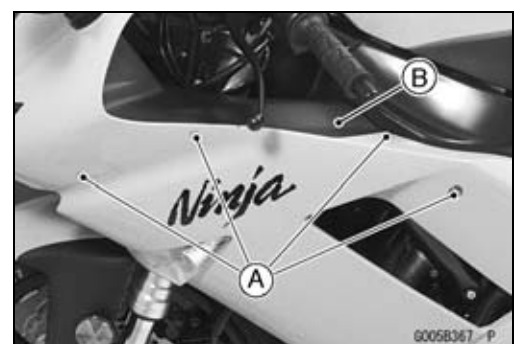

## 15-10 FRAME

### Fairings

- Remove:  
Quick Rivets [A]



- Remove:  
Quick Rivets [A]  
Left Turn Signal Lead Connector  
Separator Band (California Model)
- Remove the left middle fairing with lower inner fairing.



#### Left Middle Fairing Installation

- Install the separator band (California Model).
- Connect the left turn signal lead connector.
- Insert the projections [A] into the slots [B].
- Install:  
Left Inner Cover (see Inner Cover Installation)  
Washers and Bolts

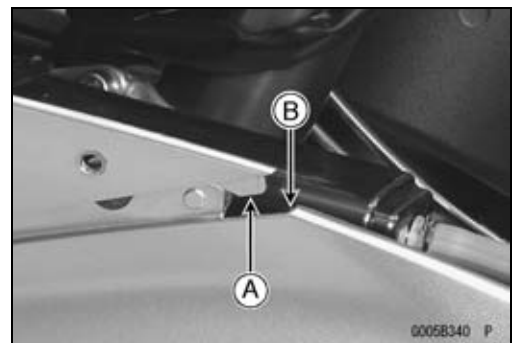

#### Right Middle Fairing Removal

- Remove:  
Lower Fairings (see Lower Fairing Removal)  
Bolts [A] with Washers  
Right Inner Cover [B] (see Inner Cover Removal)

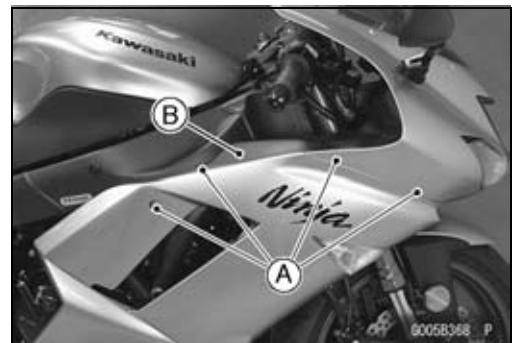

- Remove:  
Quick Rivets [A]





## Fairings

- Remove:  
Quick Rivets [A]



- Remove:  
Right Turn Signal Lead Connector [A]  
Fan Motor Connector [B]  
Relay Box Connectors [C]  
Fuse Box [D]
- Remove the right middle fairing.

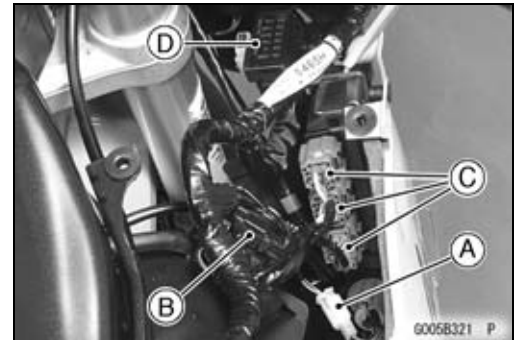

### Right Middle Fairing Installation

- Install the Fuse Box.
- Connect:  
Relay Box Connectors  
Fan Motor Connector  
Right Turn Signal Lead Connector
- Insert the projections [A] into the slots [B].
- Install:  
Right Inner Cover (see Inner Cover Installation)  
Washers and Bolts

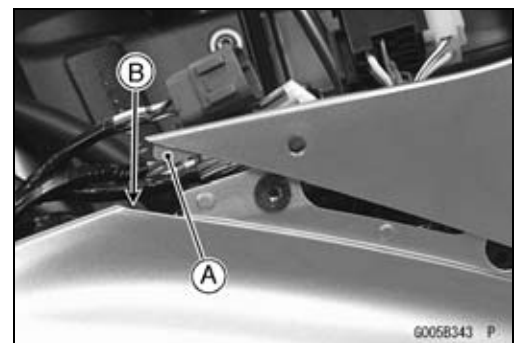

### Windshield Removal

- Remove:  
Bolts [A] and Washers  
Windshield [B]

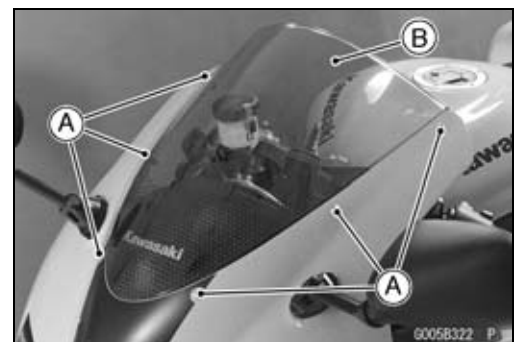

### Windshield Installation

- Put the front tongue [A] into the hollow [B].
- Install the washers and bolts.

**Torque - Windshield Mounting Bolts: 0.4 N·m (0.04 kgf·m, 4 in·lb)**

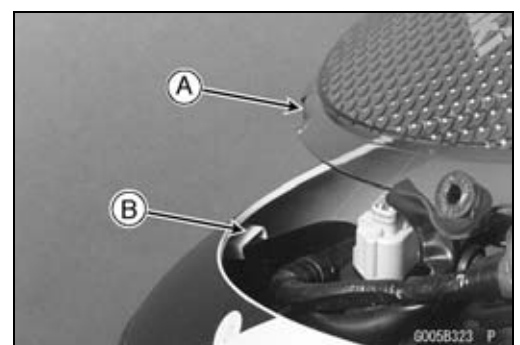

## 15-12 FRAME

### Fairings

#### Upper Fairing Removal

- Remove:
  - Lower Fairings (see Lower Fairing Removal)
  - Middle Fairing (see Left Middle Fairing Removal)
  - Windshield (see Windshield Removal)
  - Inner Cover (see Inner Cover Removal)
  - Headlight Lead Connectors [A]
  - Clamps (Open) [B]
  - City Light Connector [C]
- Disconnect:
  - Meter Lead Connector [A]
  - Vehicle-down Sensor Connector [B]
  - Immobilizer Amplifier Connector (Equipped Models)
- Remove:
  - Turn Signal Relay [C]
  - Bolts [D]
  - Upper Fairing
- Pull out the upper fairing forward.

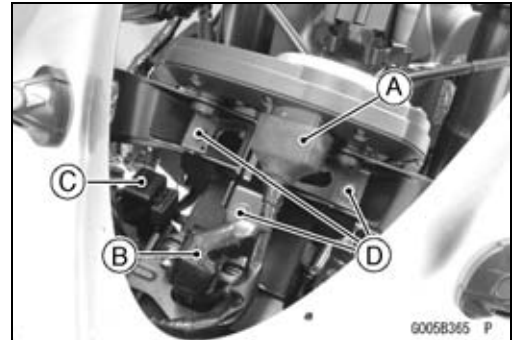
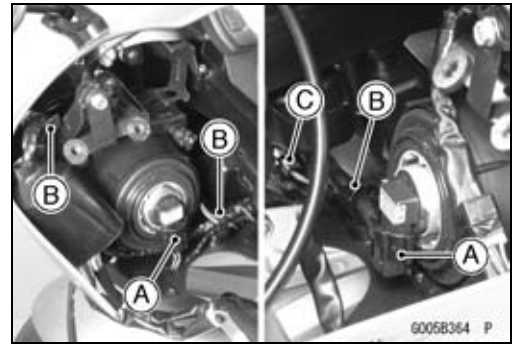

#### Upper Fairing Disassembly

- Remove:
  - Center Inner Fairing [A] (see Center Inner Fairing Removal)
  - Nuts [B]
  - Rear View Mirrors (Right and Left)
  - Meter Unit [C] with bracket (see Meter Unit Removal in the Electrical System chapter)
  - Screws [D]
  - Bolts [E]
  - Headlight (see Headlight Removal in the Electrical System chapter)
  - City Light
  - Holdings

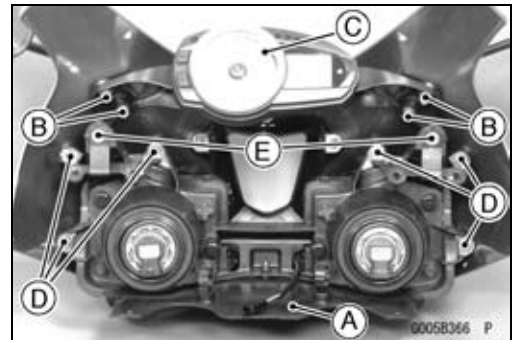

#### Upper Fairing Assembly

- Install the removed parts (see appropriate chapters).

#### Upper Fairing Installation

- Install the removed parts (see appropriate chapters).

#### Inner Cover Removal

- Remove the bolt [A].
- Remove the inner cover [B].
- Remove the inner cover by pulling the rear portion [C] of it up and forward, clear the cover from the stoppers.
- Remove the inner cover by pulling the front portion [D] of it up and backward clear the cover from the stoppers.

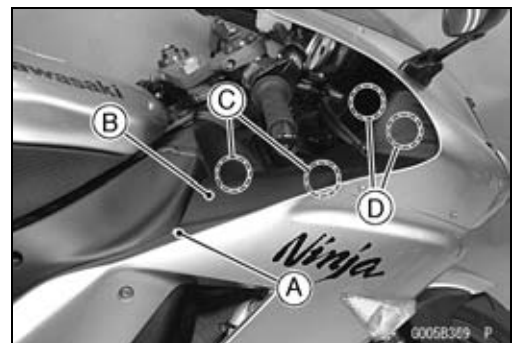

## Fairings

### Inner Cover Installation

- Insert the rear portion of the cover under the middle fairing.
- Fit the projections [B] of the inner cover on to the holes [A] of the upper fairing.
- Tighten the bolt.

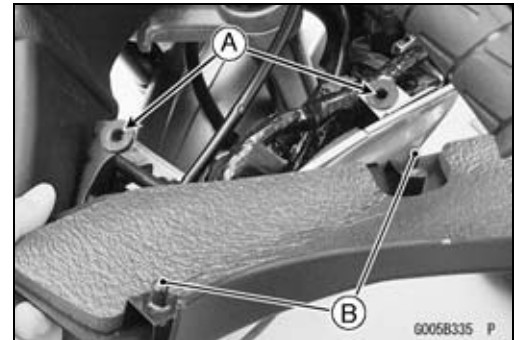
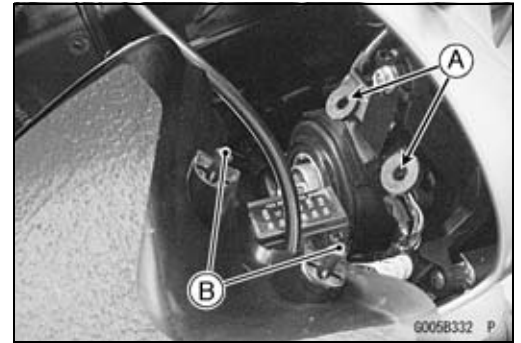

### Center Inner Fairing Removal

- Remove:
  - Upper Fairing (see Upper Fairing Removal)
  - Screws [A]
  - Center Inner Fairing [B]
- Slide out the center inner fairing backward [C].

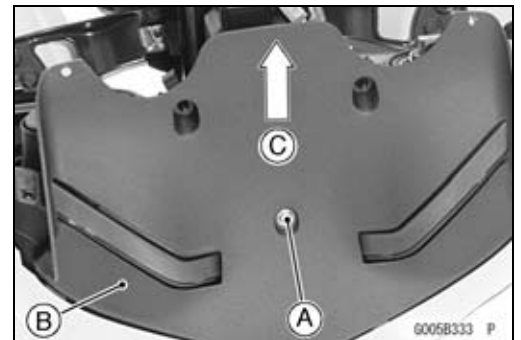

### Center Inner Fairing Installation

- Insert the tangs [A] of the center inner fairing into the holes [B] of the upper fairing.

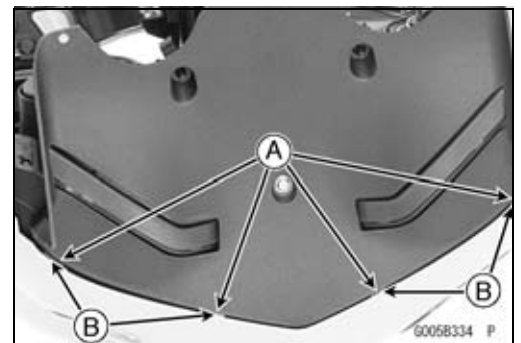

### Lower Inner Fairing Removal

- Remove:
  - Middle Fairing (see Middle Fairing Removal)
  - Bolts [A]
  - Quick Rivet [B]
  - Inner Fairing [C]

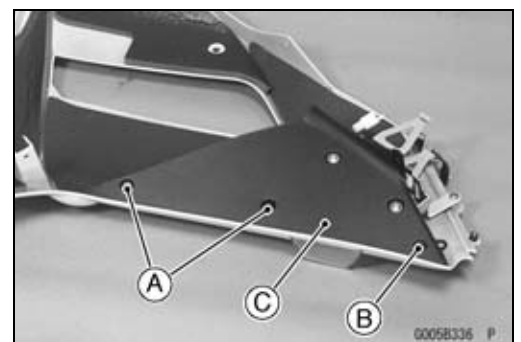

## 15-14 FRAME

### Fairings

#### *Lower Inner Fairing Installation*

- Tighten:
  - Bolts [A]
  - Quick Rivets [B]
- Install the removed parts (see appropriate chapters).

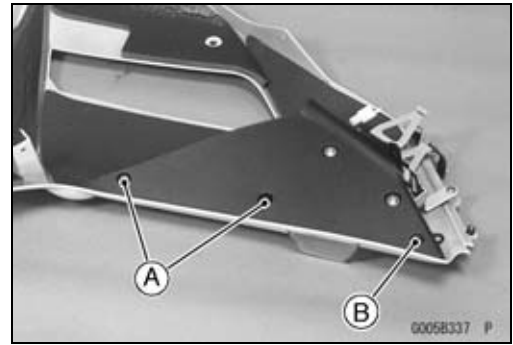

## Side Covers

### *Left Side Cover Removal*

- Remove:
  - Bolt [A]
  - Projections [B]
- Pull out the side cover [C].

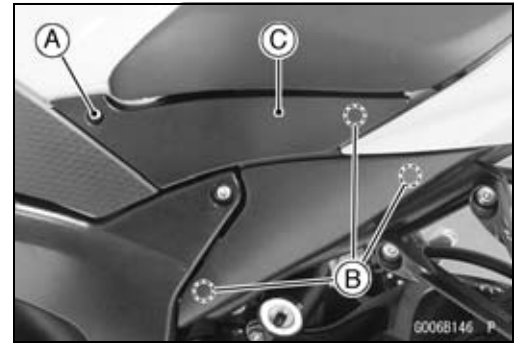

### *Left Side Cover Installation*

- Insert the projections [A] into the holes [B].
- Tighten the bolt.

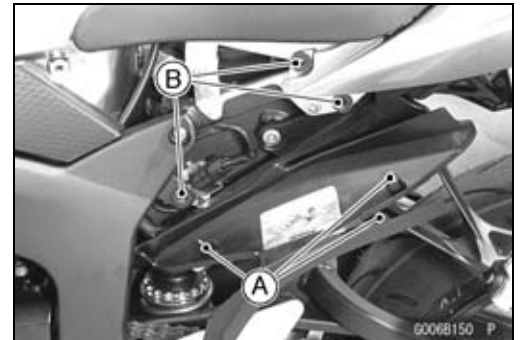

### *Right Side Cover Removal*

- Remove:
  - Bolts [A]
  - Projections [B]
- Pull out the side cover [C].

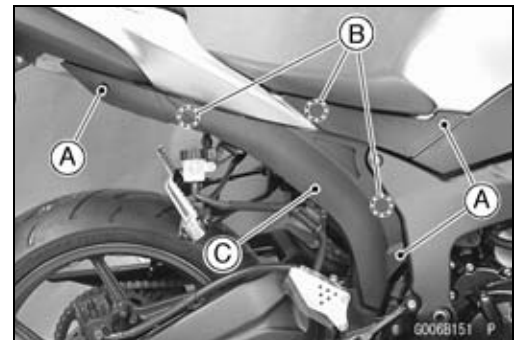

### *Right Side Cover Installation*

- Insert the projections [A] into the holes [B].

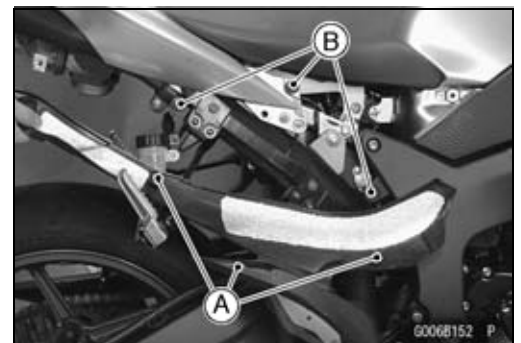

## 15-16 FRAME

### Seat Cover

#### **Seat Cover Removal**

- Remove:
  - Seats (see Rear/Front Seat Removal)
  - Bolts [A] with Washer

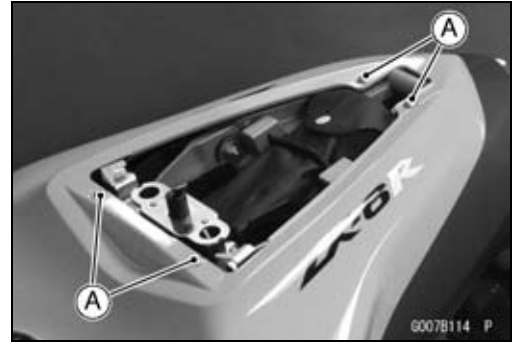

- Remove:
  - Bolts [A] with Washer

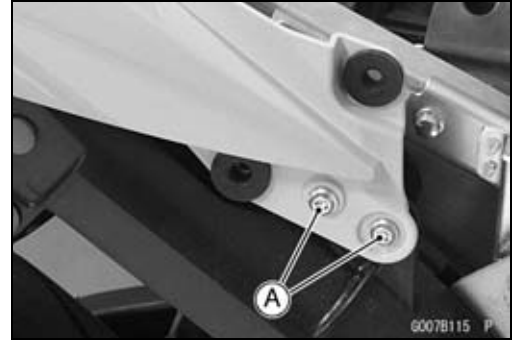

- Remove:
  - Bolt [A] with Washer
  - Seat Cover [B] (backward)

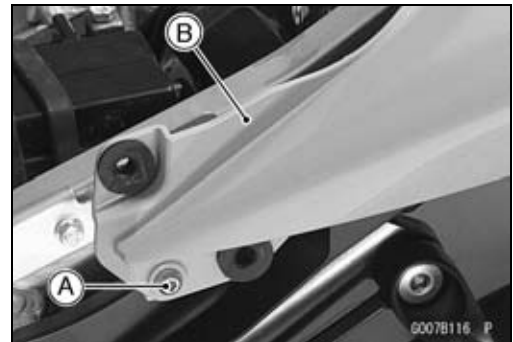

#### **Seat Cover Installation**

- Install the removed parts.

## Engine Cover

### Heat Insulation Plate Removal

- Remove:
  - Lower Fairing (see Lower Fairing Removal)
  - Middle Fairing (see Left Middle Fairing Removal)
  - Radiator Upper Bolts [A] (both side)
  - Radiator Lower Bolt [B]
- Move the radiator to the front side.

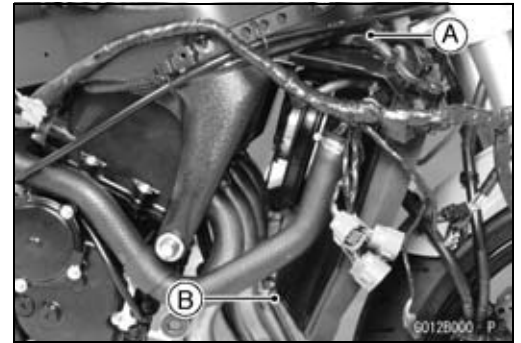

- Remove the heat insulation plate [B].
- Pull out the right side of the plate to clear the projections [A] from the stoppers.

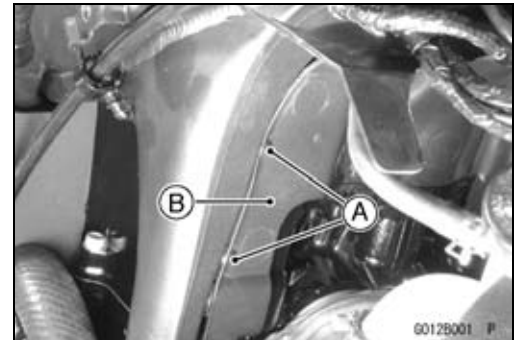

### Heat Insulation Plate Installation

- Insert the projections [A] into the holes [B] of the frame.

#### NOTE

○ Install the plate from the left side first.

- Install the removed parts (see appropriate chapters).

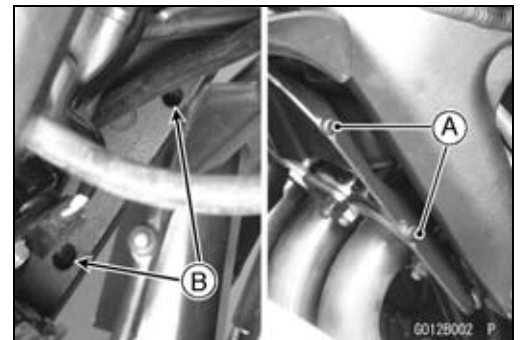

### Heat Insulation Rubber Plate Removal

- Remove:
  - Fuel Tank (see Fuel Tank Removal in the Fuel System chapter)
  - Air Cleaner Housing (see Air Cleaner Housing Removal in the Fuel System chapter)
  - Throttle Body Assy (see Throttle Body Assy Removal in the Fuel System chapter)
  - Alternator Lead Connector [A]
  - Gear Position Sensor Lead Connector [B]
  - Water Temperature Sensor Lead
  - Crankshaft Sensor Lead
  - Clamps [C]
  - Heat Insulation Rubber Plate [D]

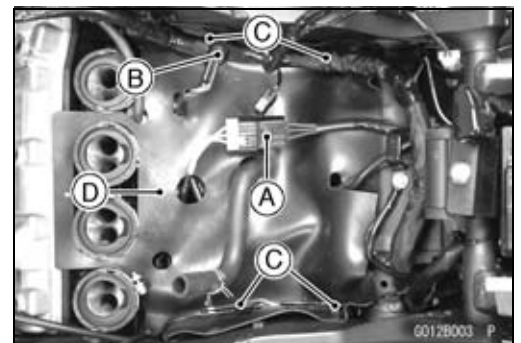

## 15-18 FRAME

### Engine Cover

#### **Heat Insulation Rubber Plate Installation**

- Install the heat insulation rubber plate [A] in throttle body (#2, #3) [B] so that the white paint face [C] up.
- Install:
  - Water Temperature Sensor Lead [D]
  - Alternator Lead [E]
  - Gear Position Sensor Lead [F]
  - Crankshaft Sensor Lead [G]
  - Coolant Hose [H]
  - Breather Hose [I]
  - Starter Motor Lead [J]
  - Battery Negative Cable [K]
  - Clamps with Main Harness [L]
  - Clamp with Speed Sensor Lead of Main Harness [M]
  - Clamp [N]

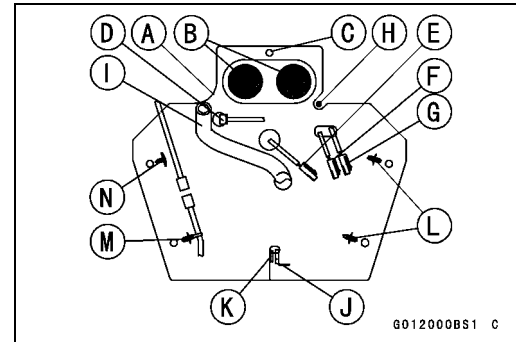



## Fenders

### Front Fender Removal

- Remove:
  - Brake Hose Clamps [A] (Both Side)
  - Bolts [B] (Both Side)
- Remove the front fender assy [C].

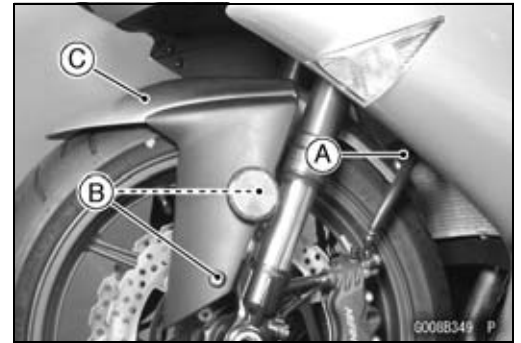

- Remove:
  - Bolts [A]
- Separate the front fender cover [B] and front fender [C].

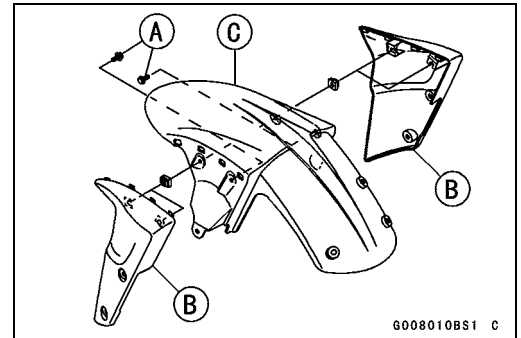

### Front Fender Installation

- Install the front fender assy to the front fork.
- Tighten:
  - Torque - Front Fender Mounting Bolts: 3.9 N·m (0.40 kgf·m, 35 in·lb)**
- Install the brake hose clamps to the front fender holes.

### Flap and Rear Fender Removal

- Remove:
  - Seats (see Rear/Front Seat Removal)
  - Seat Cover (see Seat Cover Removal)
  - Fuel Tank (see Fuel Tank Removal in the Fuel System (DFI) chapter)
  - Muffler Cover Bolts [A] (Both Side)
  - Muffler Covers [B]
- After the muffler body mounting bolts removed, the muffler body [C] moves downward little.
- Remove the right muffler cover [D] backward to clean the stoppers [E].
- Remove the left muffler cover [F].
- Remove:
  - Clamps [A]
  - Connectors [B]

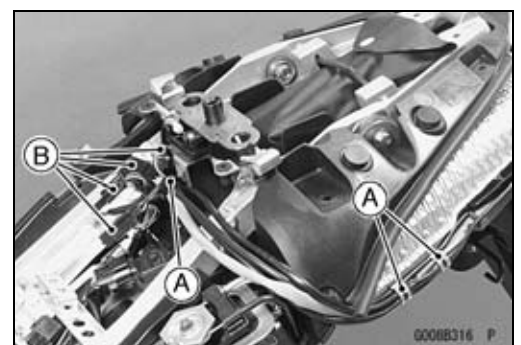
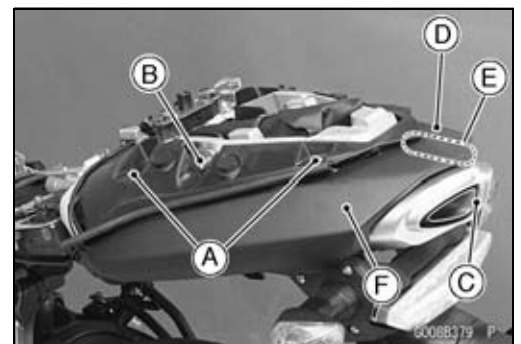

## 15-20 FRAME

### Fenders

- Remove:
  - Bolts [A] (Both Side)
  - Turn Signal Lights [B] (Both Side)

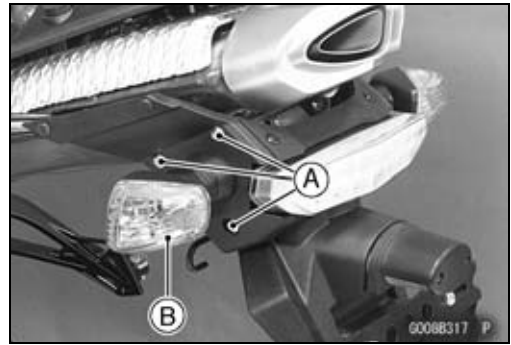

- Remove:
  - Bolts [A] (Both Side)
  - Bracket [B] (Both Side)

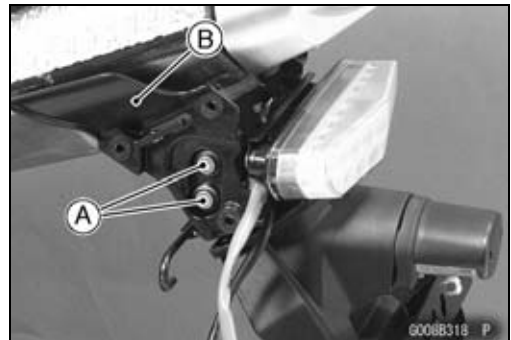

- Remove:
  - Bolts [A] (Both Side)
  - Bracket [B]
  - Flap [C] with Tail/Brake Light
- Separate the flap and Light.

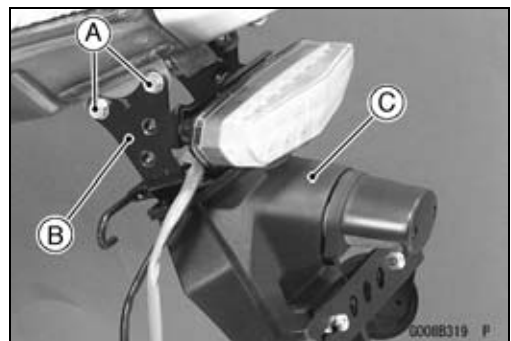

- Remove:
  - Muffler Body (see Muffler Body Removal in the Engine Top End chapter)
  - Rear Exhaust Pipe (see Rear Exhaust Pipe Removal in the Engine Top End chapter)
- Remove:
  - Bolt [A]
  - Cover [B]

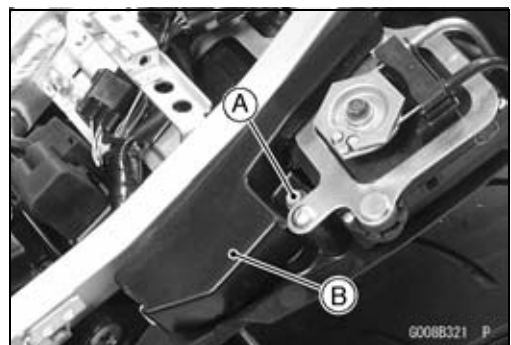

- Remove:
  - Screws [A]
  - Seat Lock Assy [B]
  - Screw [C]
  - Bolts [D]
  - Exhaust Butterfly Valve Actuator [E]

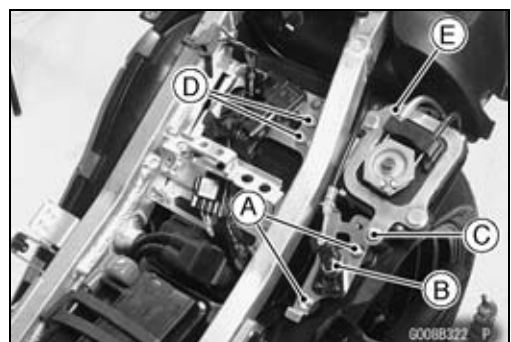

**Fenders**

- Remove:  
Connectors [A]  
Grommet [B]

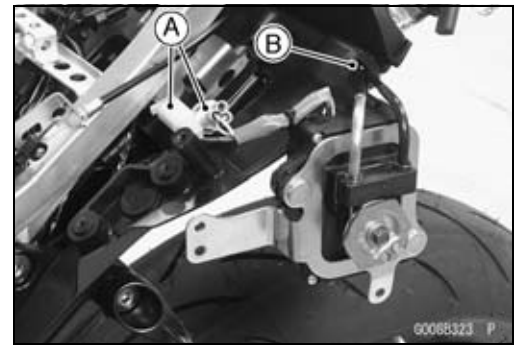

- Remove:  
Rear Footpeg Bracket Bolts [A] (Both Side)  
Rear Footpeg Bracket Assy [B]

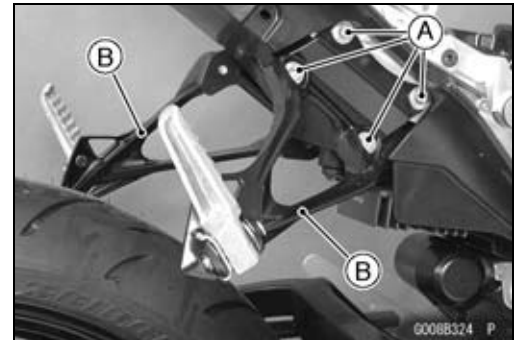

- Remove:  
Band [A]  
Cables [B]  
Battery [C]

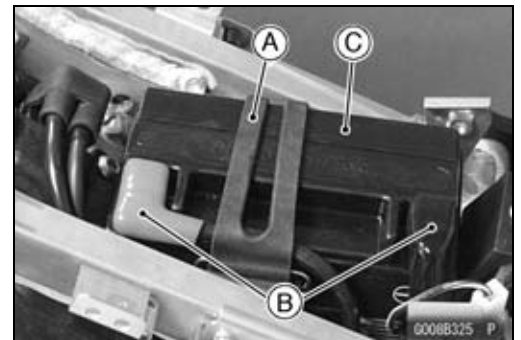

- Remove:  
Bolts [A]  
Battery Case [B]  
Starter Relay [C] (pull out)

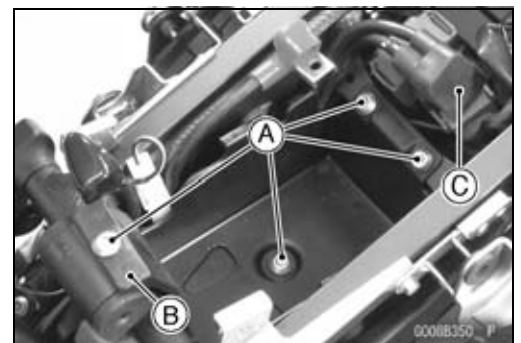

- Remove:  
Regulator/Rectifier Bracket Nuts [A]

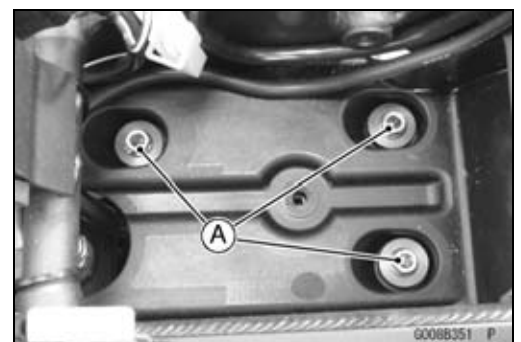

## 15-22 FRAME

### Fenders

- Remove:  
Main Harness Clamp [A]



- Remove:  
Quick Rivets [A] (both side)

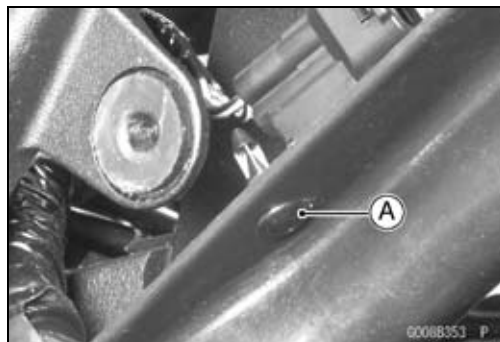

- Remove:  
Screws [A]  
Rocks with Bracket [B]

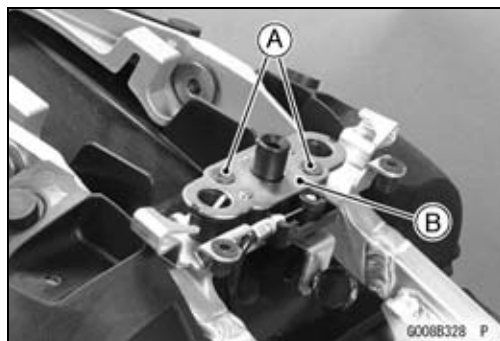

- Remove:  
Bolts [A]  
Rear Fender [B]

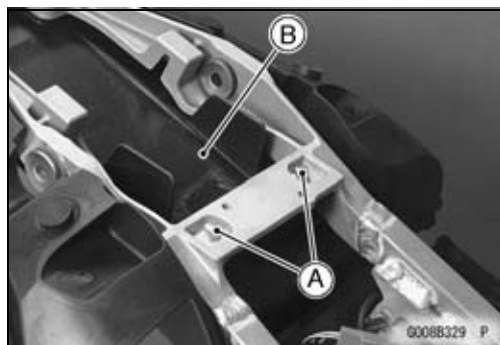

## Fenders

### **Flap and Rear Fender Installation**

- Install the removed parts (see appropriate chapters).
- Tighten:
  - Torque - Rear Footpeg Bracket Bolts: 25 N·m (2.5 kgf·m, 18 ft·lb)**
- Note the following procedure for the muffler covers installation.
  - Install the left cover [A].
  - Fit the stoppers [B] of left cover into the slits of the right cover [C].
  - Tighten:
    - Torque - Muffler Body Mounting Bolts: 28 N·m (2.8 kgf·m, 21 ft·lb)**
  - Tighten the muffler cover bolts.
- Install the harness clamps in accordance with Cable, Wire, and Hose Routing section in the Appendix chapter.

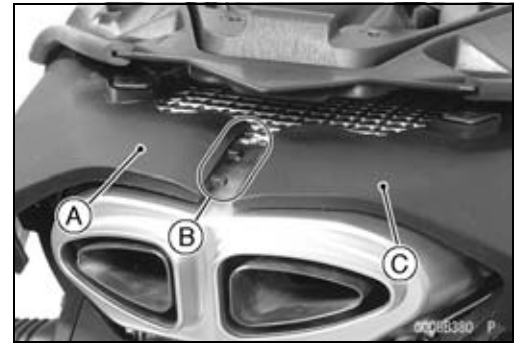

## 15-24 FRAME

### Frame

#### **Rear Frame Removal**

- Remove:
  - Rear Fender (see Rear Fender Removal)
  - Frame Bolts [A] and Nuts

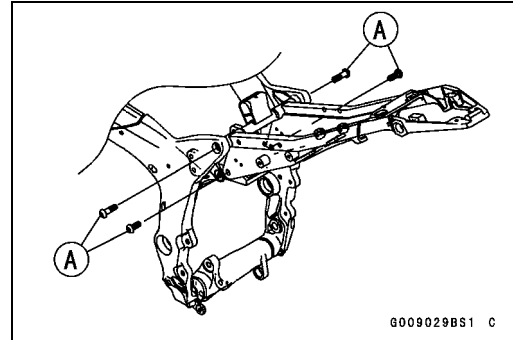

#### **Rear Frame Installation**

- Apply a non-permanent locking agent to the threads of rear frame bolt.
- Tighten:
  - Torque - Rear Frame Bolts and Nuts: 59 N·m (6.0 kgf·m, 44 ft·lb)
  - Rear Footpeg Bracket Bolts: 25 N·m (2.5 kgf·m, 18 ft·lb)

#### **Frame Inspection**

- Visually inspect the frame for cracks, dents, bending, or warp.
- ★ If there is any damage to the frame, replace it.

#### **⚠ WARNING**

A repaired frame may fail in use, possibly causing an accident. If the frame is bent, dented, cracked, or warped, replace it.

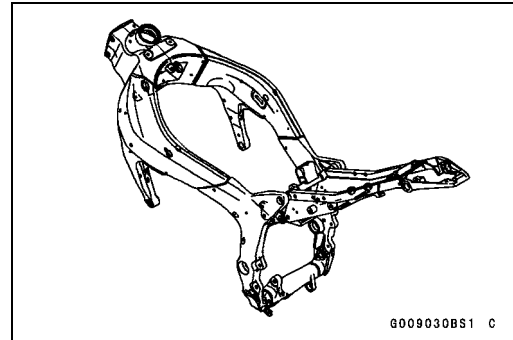

## Sidestand

### Sidestand Removal

- Raise the rear wheel off the ground with the stand.
- Remove:
  - Lower Fairings (see Lower Fairing Removal)
- Disconnect the sidestand switch lead connector [A].



- Remove:
  - Spring [A]
  - Sidestand Bolt Locknut
  - Sidestand Bolt [B]
  - Sidestand [C]
  - Switch Bracket Bolts [D]
  - Sidestand Bracket Bolts [E]

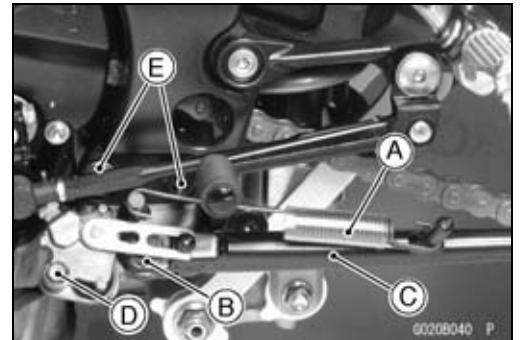

### Sidestand Installation

- Apply a non-permanent locking agent to the bracket bolts.
- Apply grease to the sliding area [A] of the sidestand [B] and thread of the sidestand bolt [C].
- Tighten the bolt and lock them with the nut.

**Torque - Sidestand Bracket Bolts [D]: 49 N·m (5.0 kgf·m, 36 ft·lb)**

**Sidestand Bolt: 44 N·m (4.5 kgf·m, 32 ft·lb)**

- Hook the spring [E] so that the long spring end side upward.
- Install the spring hook direction as shown.
- Install the switch bracket and sidestand switch.
- Apply a non-permanent locking agent to the thread of the switch bolt.

- Tighten:
  - Torque - Sidestand Switch Bolt [F]: 8.8 N·m (0.90 kgf·m, 78 in·lb)**

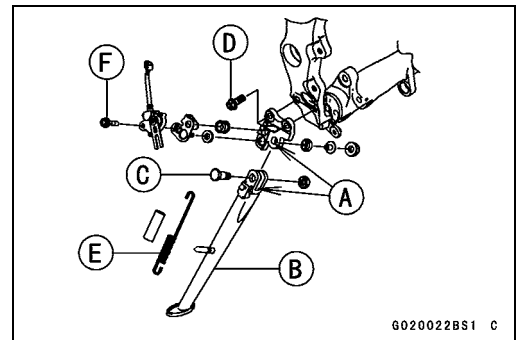





# Electrical System

## Table of Contents

Parts Location.....	16-3	Stick Coil Installation.....	16-46
Exploded View.....	16-4	Stick Coil Inspection.....	16-47
Wiring Diagram (United States and Canada) ZX600P7F.....	16-10	Stick Coil Primary Peak Voltage ..	16-47
Wiring Diagram (United States and Canada) ZX600P8F.....	16-12	Spark Plug Removal.....	16-48
Wiring Diagram (Other than United States, Canada, Australia and Malaysia) ZX600P7F.....	16-14	Spark Plug Installation.....	16-48
Wiring Diagram (Other than United States, Canada, Australia and Malaysia) ZX600P8F.....	16-16	Spark Plug Clean and Inspection.	16-48
Wiring Diagram (Australia) ZX600P7F.....	16-18	Camshaft Position Sensor Removal.....	16-49
Wiring Diagram (Australia) ZX600P8F.....	16-20	Camshaft Position Sensor Installation.....	16-49
Wiring Diagram (Malaysia) ZX600P7F.....	16-22	Camshaft Position Sensor Inspection.....	16-49
Wiring Diagram (Malaysia) ZX600P8F.....	16-24	Camshaft Position Sensor Peak Voltage Inspection.....	16-50
Specifications.....	16-26	Interlock Operation Inspection.....	16-51
Special Tools and Sealant.....	16-27	IC Igniter Inspection.....	16-52
Precautions.....	16-28	Electric Starter System.....	16-54
Electrical Wiring.....	16-29	Starter Motor Removal.....	16-54
Wiring Inspection.....	16-29	Starter Motor Installation.....	16-54
Battery.....	16-30	Starter Motor Disassembly.....	16-55
Battery Removal.....	16-30	Starter Motor Assembly.....	16-55
Battery Installation.....	16-30	Brush Inspection.....	16-56
Battery Activation.....	16-30	Commutator Cleaning and Inspection.....	16-56
Precautions.....	16-33	Armature Inspection.....	16-57
Interchange.....	16-33	Brush Lead Inspection.....	16-57
Charging Condition Inspection.....	16-34	Right-hand End Cover Assembly Inspection.....	16-57
Refreshing Charge.....	16-34	Starter Relay Inspection.....	16-57
Charging System.....	16-36	Lighting System.....	16-60
Alternator Cover Removal.....	16-36	Headlight Beam Horizontal Adjustment.....	16-60
Alternator Cover Installation.....	16-36	Headlight Beam Vertical Adjustment.....	16-60
Stator Coil Removal.....	16-36	Headlight Bulb Replacement.....	16-60
Stator Coil Installation.....	16-37	City Light Bulb Replacement.....	16-61
Alternator Rotor Removal.....	16-37	Headlight Removal/Installation.....	16-61
Alternator Rotor Installation.....	16-37	Tail/Brake Light (LED) Removal...	16-61
Alternator Inspection.....	16-38	Tail/Brake Light (LED) Installation	16-62
Regulator/Rectifier Removal.....	16-39	License Plate Light Bulb Replacement.....	16-62
Regulator/Rectifier Inspection.....	16-40	Turn Signal Light Bulb Replacement.....	16-63
Charging Voltage Inspection.....	16-41	Turn Signal Light Removal.....	16-65
Ignition System.....	16-43	Turn Signal Relay Inspection.....	16-66
Crankshaft Sensor Removal.....	16-44	Air Switching Valve.....	16-69
Crankshaft Sensor Installation.....	16-44	Air Switching Valve Operation Test.....	16-69
Crankshaft Sensor Inspection.....	16-45	Air Switching Valve Unit Test.....	16-69
Crankshaft Sensor Peak Voltage.	16-45	Radiator Fan System.....	16-70
Stick Coil Removal.....	16-46		

## 16-2 ELECTRICAL SYSTEM

---

Fan Motor Inspection .....	16-70	Water Temperature Sensor	
Meter, Gauge, Indicator Unit.....	16-72	Inspection.....	16-115
Meter Unit Removal .....	16-72	Speed Sensor Removal.....	16-115
Meter Unit Disassembly .....	16-72	Speed Sensor Installation.....	16-116
Electronic Unit (Combination		Speed Sensor Inspection.....	16-116
Meter) Inspection .....	16-73	Fuel Reserve Switch Inspection...	16-117
Fuel Level Sensor Line		Oxygen Sensor Removal	
Self-Diagnosis Mode		(Equipped Models).....	16-117
Inspection.....	16-89	Oxygen Sensor Installation	
Immobilizer System (Equipped		(Equipped Models).....	16-118
Models).....	16-91	Oxygen Sensor Inspection	
Operational Cautions .....	16-91	(Equipped Models).....	16-118
Key Registration.....	16-91	Relay Box .....	16-119
Immobilizer System Parts		Relay Box Removal .....	16-119
Replacement .....	16-107	Relay Circuit Inspection .....	16-119
Immobilizer System Inspection ....	16-109	Diode Circuit Inspection .....	16-120
Switches and Sensors.....	16-111	Fuse.....	16-122
Brake Light Timing Inspection.....	16-111	30 A Main Fuse Removal.....	16-122
Brake Light Timing Adjustment ....	16-111	Fuse Box Fuse Removal.....	16-122
Gear Position Switch Removal ....	16-111	10 A ECU Fuse Removal.....	16-122
Gear Position Switch Installation .	16-112	Fuse Installation.....	16-123
Gear Position Switch Inspection ..	16-113	Fuse Inspection.....	16-123
Switch Inspection .....	16-114		

## Parts Location

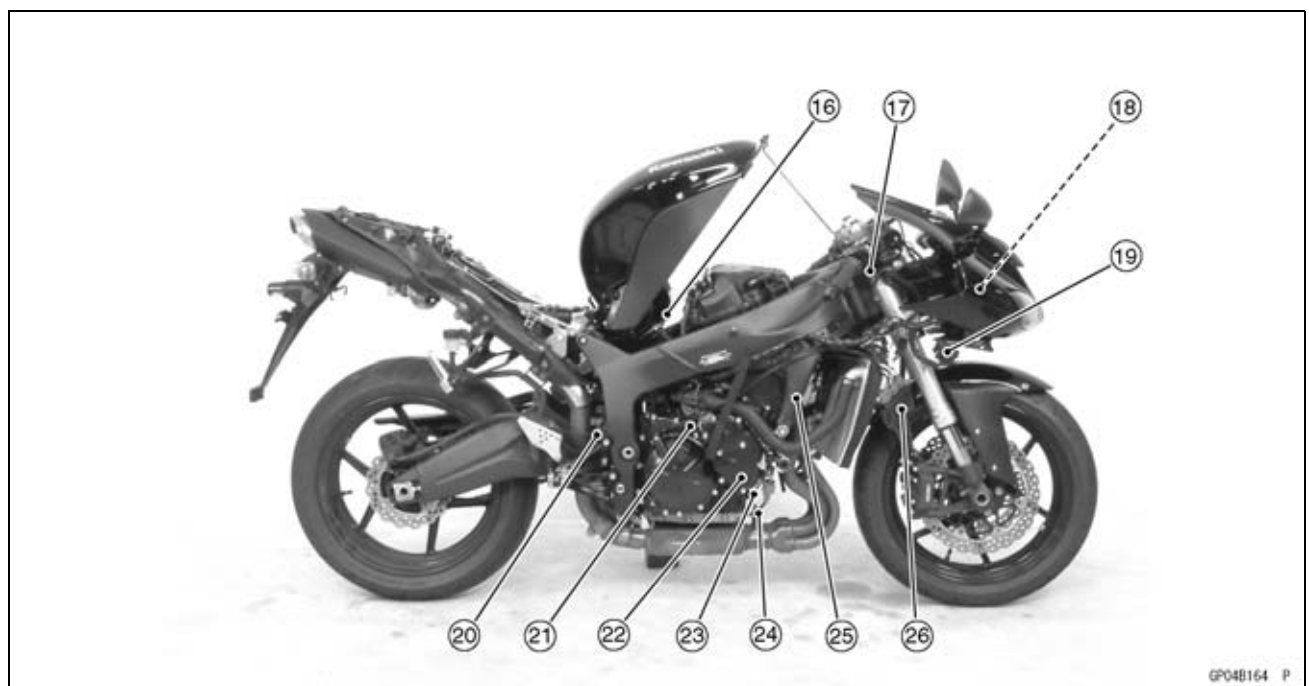
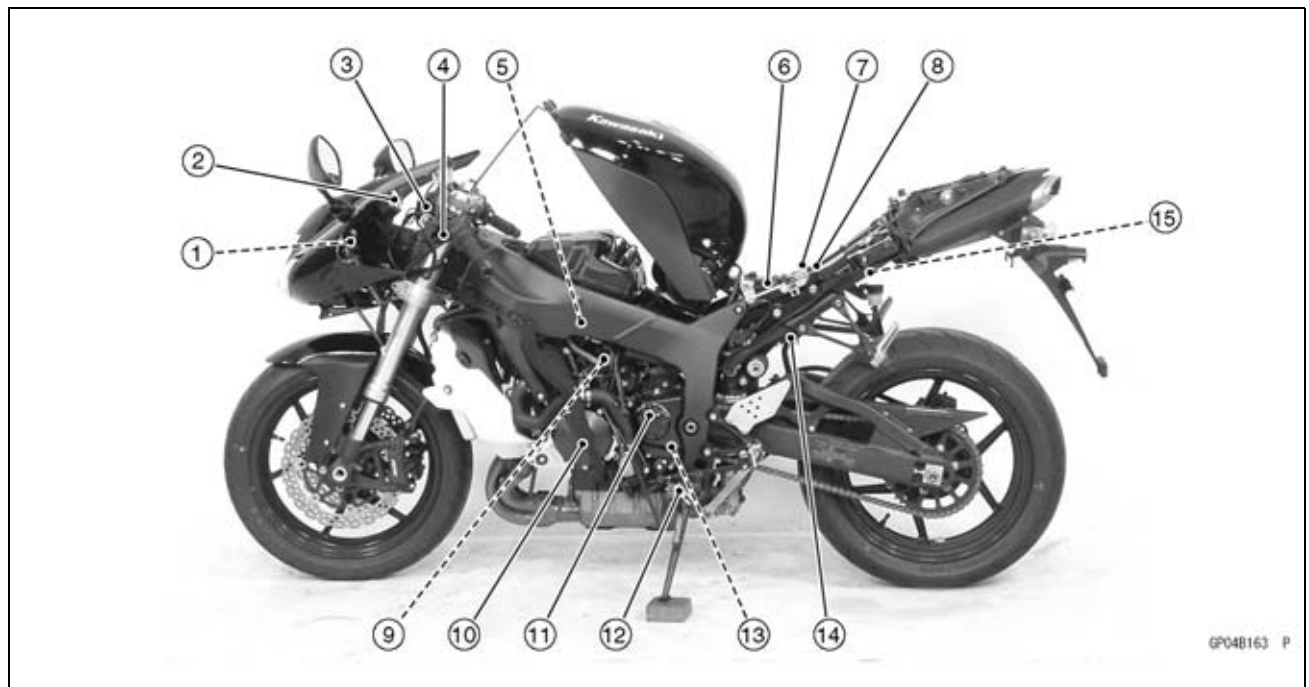

- |   |  |
|---|--|
| 1. Immobilizer Amplifier (Equipped Models)  | 14. Regulator/rectifier                |
| 2. Meter Unit                               | 15. ECU (Electric Control Unit)        |
| 3. Ignition Switch with Immobilizer Antenna | 16. Fuel Pump with Fuel Reserve Switch |
| 4. Starter Lockout Switch                   | 17. Front Brake Light Switch           |
| 5. Stick Coils                              | 18. Turn Signal Relay                  |
| 6. Battery 12 V 8 Ah                        | 19. Fuse Box with ECU Main Fuse        |
| 7. Starter Relay with Main Fuse             | 20. Rear Brake Light Switch            |
| 8. Immobilizer Diagnostic System Connector  | 21. Starter Motor                      |
| 9. Water Temperature Sensor                 | 22. Crankshaft Sensor                  |
| 10. Alternator                              | 23. Oil Pressure Switch                |
| 11. Speed Sensor                            | 24. Oxygen Sensors                     |
| 12. Side Stand Switch                       | 25. Camshaft Position Sensor           |
| 13. Gear Position Switch                    | 26. Relay Box                          |

# 16-4 ELECTRICAL SYSTEM

## Exploded View

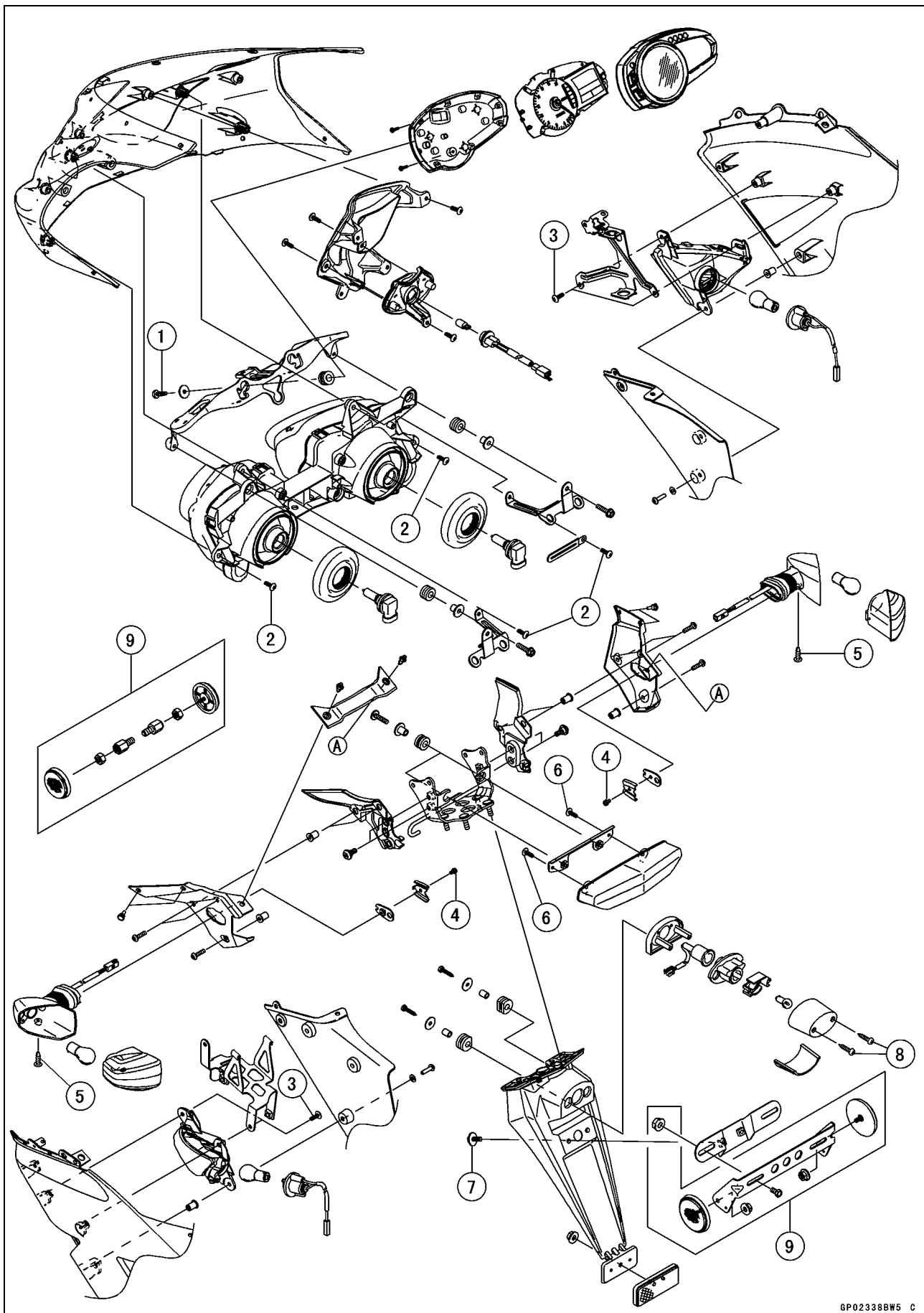

**Exploded View**

<b>No.</b>	<b>Fastener</b>	<b>Torque</b>			<b>Remarks</b>
		<b>N-m</b>	<b>kgf-m</b>	<b>ft-lb</b>	
1	Meter Mounting Screws	1.2	0.12	10 in-lb	
2	Headlight Mounting Screws	1.2	0.12	10 in-lb	
3	Front Turn Signal Light Mounting Screws	1.2	0.12	10 in-lb	
4	Rear Turn Signal Light Mounting Screws	1.2	0.12	10 in-lb	
5	Rear Turn Signal Light Lens Screws	1.0	0.10	9 in-lb	
6	Tail/Brake Light Mounting Bolts	4.0	0.40	35 in-lb	
7	Licence Plate Mounting Screws	1.2	0.12	10 in-lb	
8	Licence Plate Light Cover Screws	0.9	0.09	8 in-lb	

9. United States and Canada Models

10. California Model

# 16-6 ELECTRICAL SYSTEM

## Exploded View

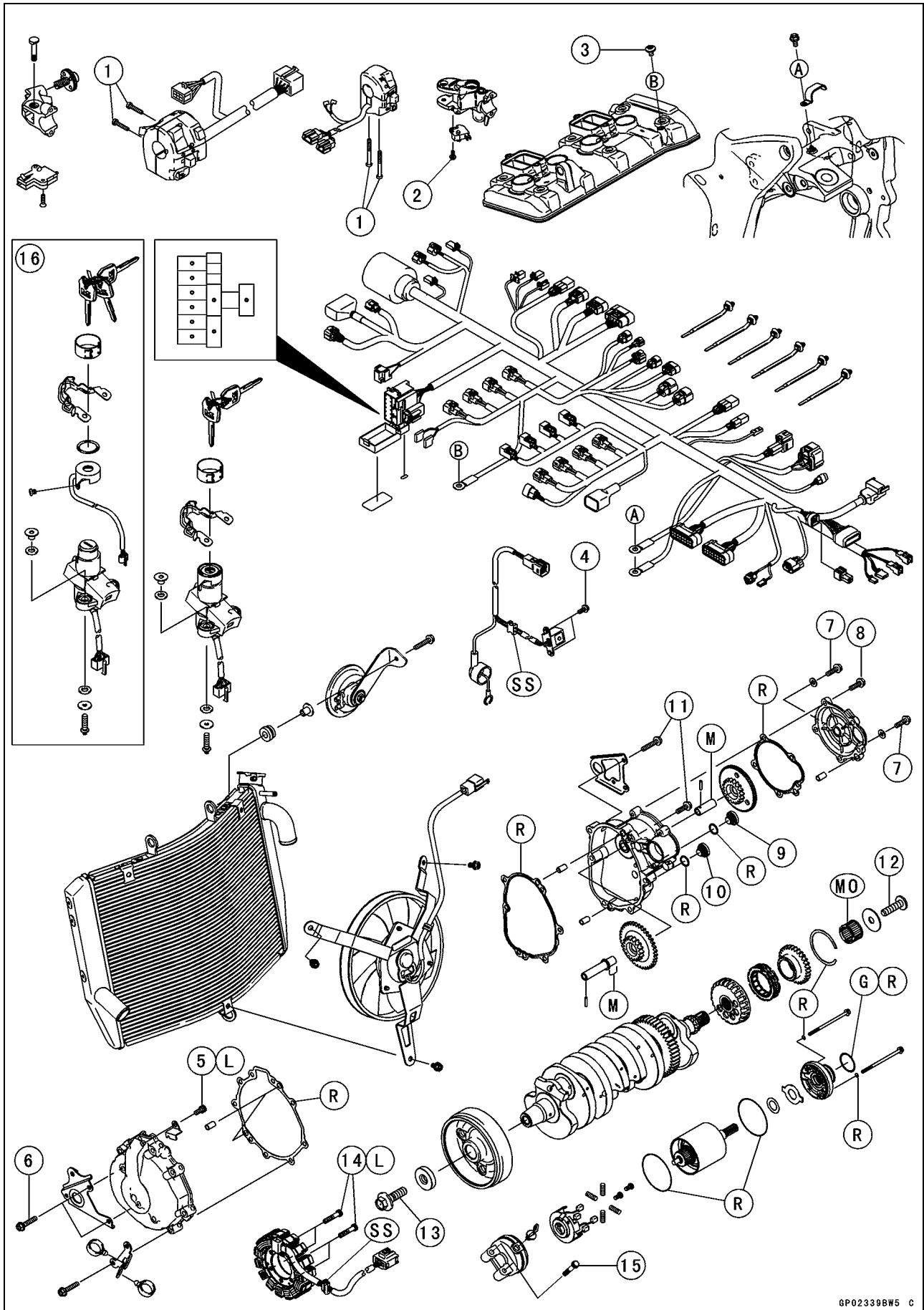

**Exploded View**

No.	Fastener	Torque			Remarks
		N-m	kgf-m	ft-lb	
1	Switch Housing Screws	3.5	0.36	31 in-lb	
2	Front Brake Light Switch Screw	1.2	0.12	10 in-lb	
3	Cylinder Head Cover Ground Bolt	9.8	1.0	87 in-lb	
4	Crankshaft Sensor Bolts	5.9	0.60	52 in-lb	
5	Alternator Lead Holding Plate Bolt	9.8	1.0	87 in-lb	L
6	Alternator Cover Bolts	9.8	1.0	87 in-lb	
7	Idle Gear Cover Bolts	9.8	1.0	87 in-lb	with Washer
8	Idle Gear Cover Bolts	9.8	1.0	87 in-lb	
9	Timing Inspection Cap	–	–	–	Hand-tighten
10	Starter Clutch Bolt Cap	–	–	–	Hand-tighten
11	Starter Clutch Cover Bolts	9.8	1.0	87 in-lb	
12	Starter Clutch Bolts	49	5.0	36	
13	Alternator Rotor Bolt	155	16	115	
14	Stator Coil Bolts	12	1.2	106 in-lb	L
15	Starter Motor Mounting Bolts	9.8	1.0	87 in-lb	

16. Immobilizer Models

G: Apply grease.

L: Apply a non-permanent locking agent.

M: Apply molybdenum disulfide grease.

MO: Apply molybdenum disulfide grease oil solution.

R: Replacement Parts

SS: Apply silicone sealant.

# 16-8 ELECTRICAL SYSTEM

## Exploded View

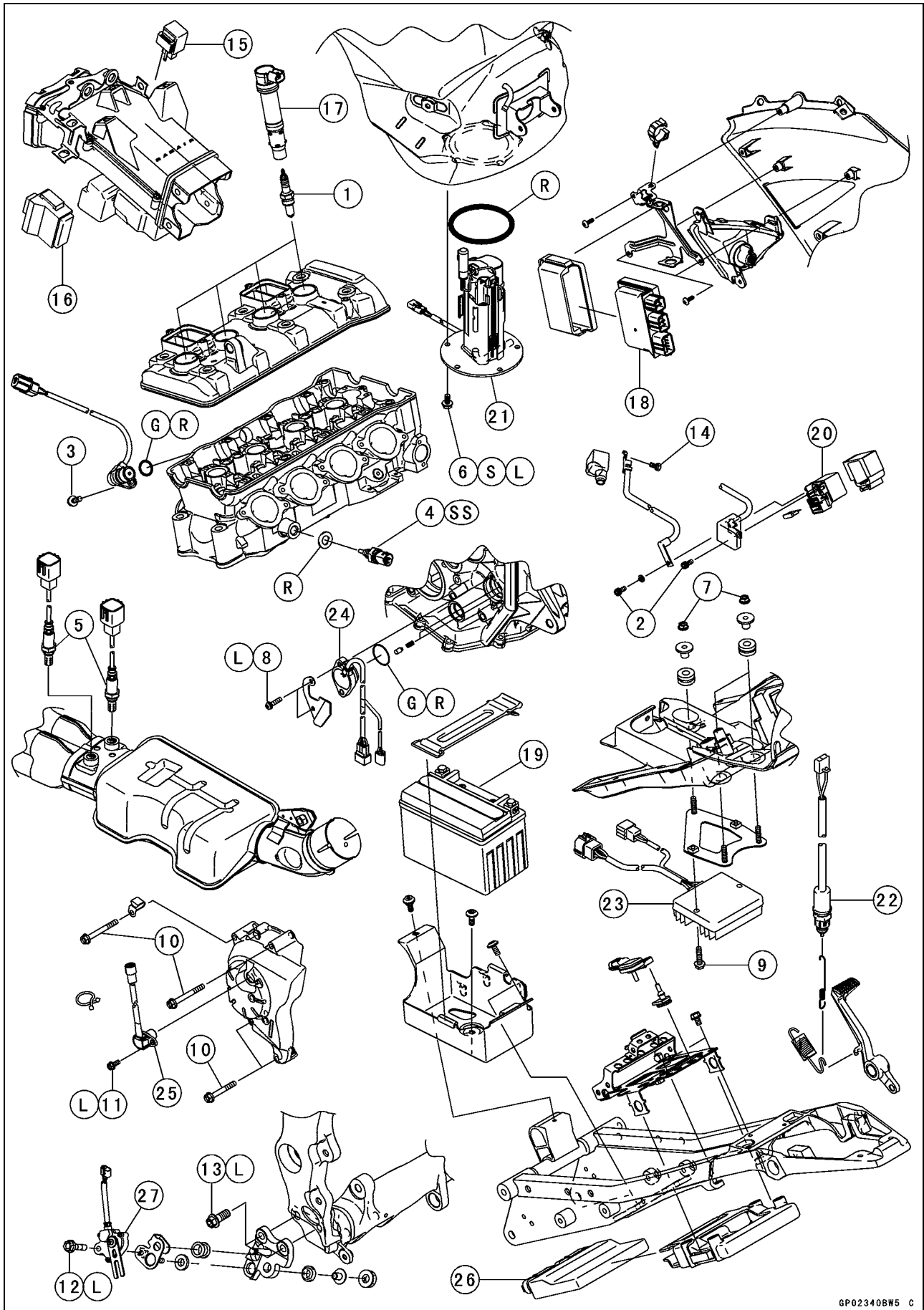



**Exploded View**

No.	Fastener	Torque			Remarks
		N·m	kgf·m	ft·lb	
1	Spark Plugs	13	1.3	113 in·lb	
2	Starter Relay Cable Terminal Bolts	4.0	0.41	35 in·lb	
3	Camshaft Position Sensor Bolt	9.8	1.0	87 in·lb	
4	Water Temperature Sensor	25	2.5	18	SS
5	Oxygen Sensors	25	2.5	18	
6	Fuel Pump Bolts	9.8	1.0	87 in·lb	L, S
7	Regulator/Rectifier Bracket Nuts	6.9	0.70	61 in·lb	
8	Gear Position Switch Screws	2.9	0.30	26 in·lb	L
9	Regulator/Rectifier Bolts	6.9	0.70	61 in·lb	
10	Engine Sprocket Cover Bolts	6.9	0.70	61 in·lb	
11	Speed Sensor Bolt	6.9	0.70	61 in·lb	L
12	Side Stand Switch Bolt	8.8	0.90	78 in·lb	L
13	Side Stand Bracket Bolt	49	5.0	36	L
14	Starter Motor Cable Terminal Bolt	2.9	0.30	26 in·lb	

- 15. Turn Signal Relay
- 16. Immobilizer Amplifier
- 17. Stick Coils
- 18. Relay Box
- 19. Battery 12 V 8 Ah
- 20. Starter Relay
- 21. Fuel Pump
- 22. Rear Brake Light Switch
- 23. Regulator/Rectifier
- 24. Gear Position Switch
- 25. Speed Sensor
- 26. ECU
- 27. Side Stand Switch

G: Apply grease.

L: Apply a non-permanent locking agent.

R: Replacement Parts

S: Follow the specific tightening sequence.

SS: Apply silicone sealant.

# 16-10 ELECTRICAL SYSTEM

## Wiring Diagram (United States and Canada) ZX600P7F

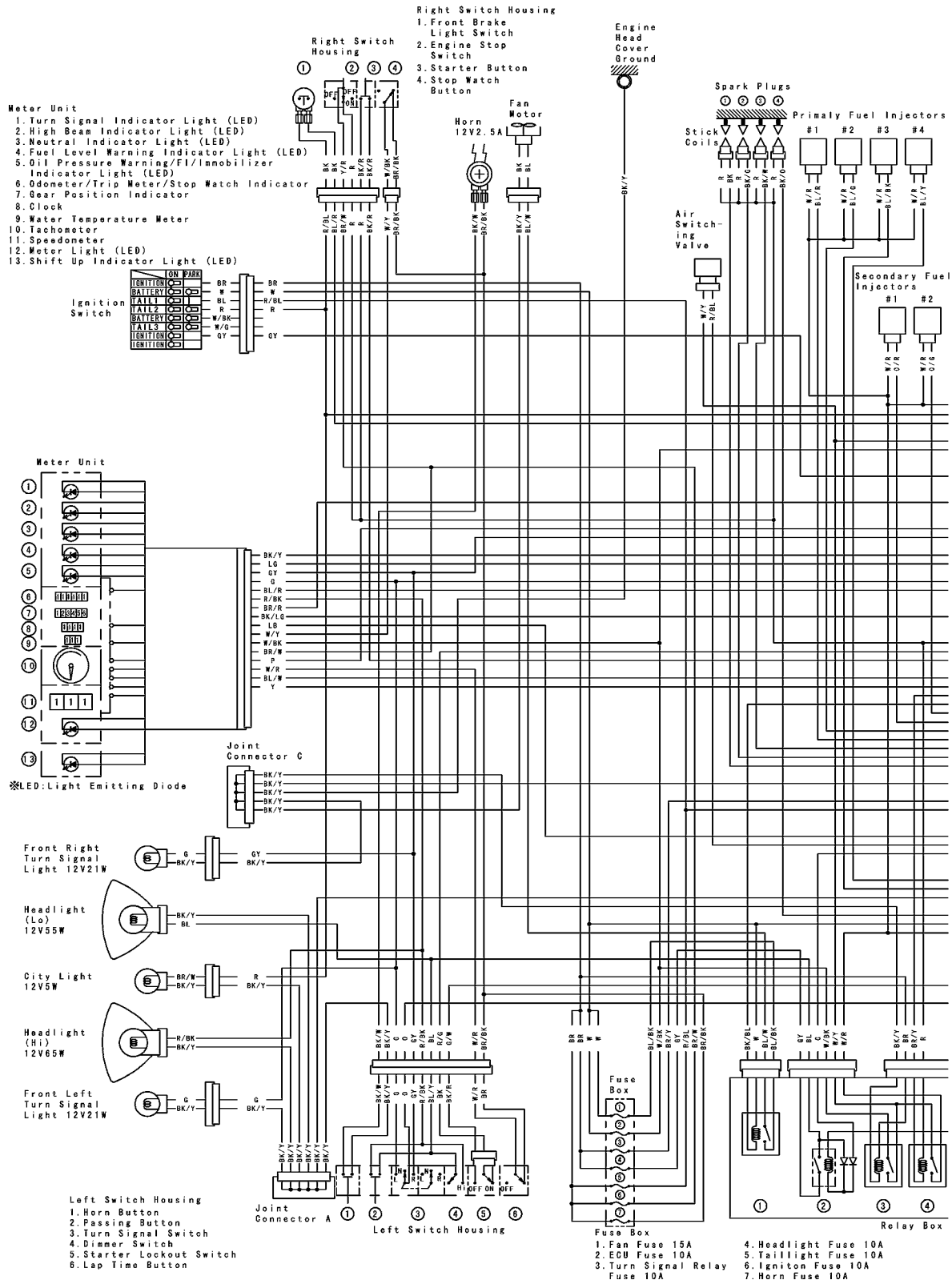

**LEFT HANDLEBAR SWITCH CONNECTIONS**

Horn Button	Turn Signal Switch	Dimmer Switch	Starter Lockout Switch	Lap Time Button	Passing Button
Color BK/W BK/Y	Color G 0 GY	Color BL/YR/BK	Color BK BK/R	Color W/R BR	Color BL/YR/BK
Push	L	HI	Clutch Lever	Push	Push
Released	R	LO	Released	Push	Push

## Wiring Diagram (United States and Canada) ZX600P7F

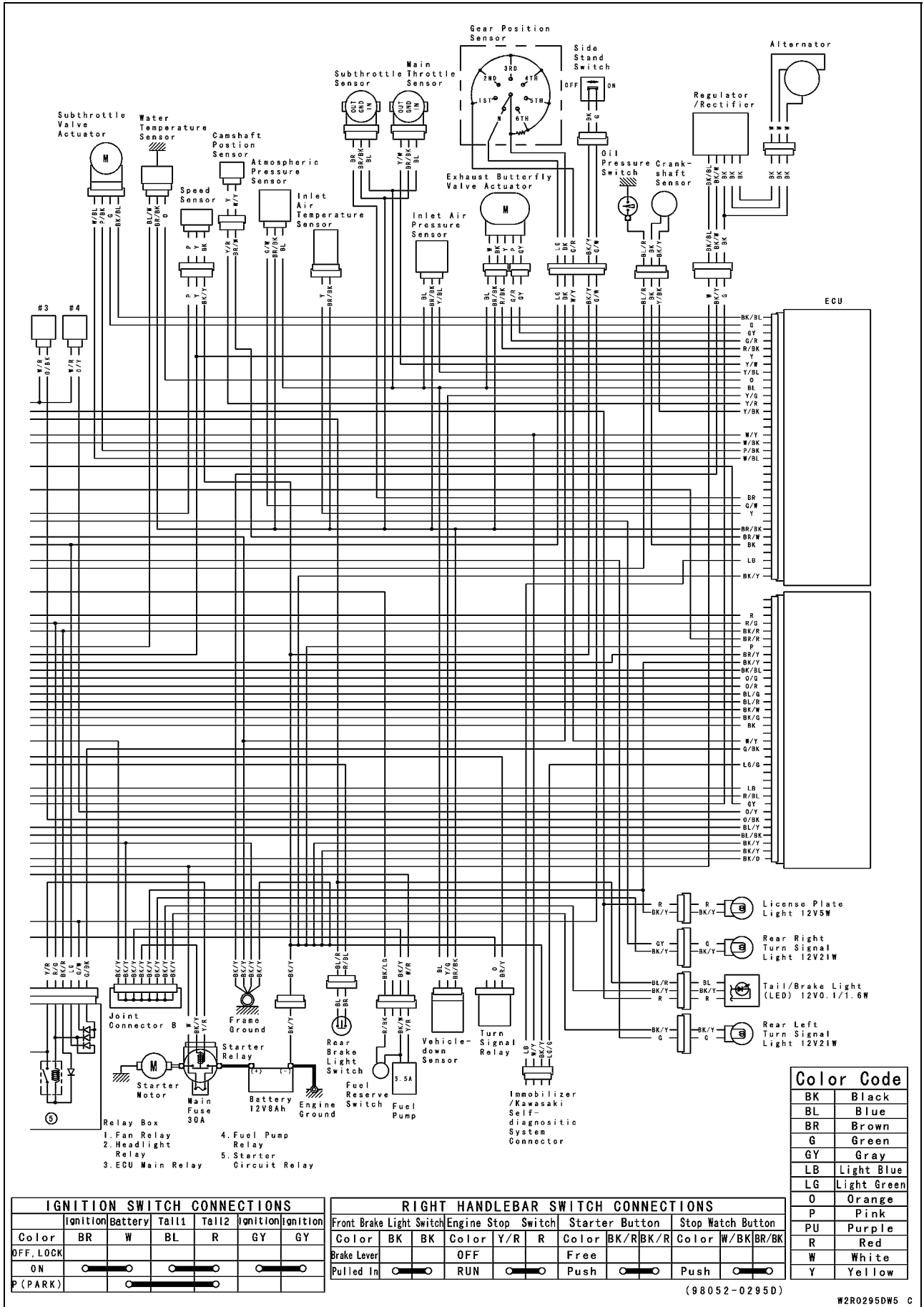

# 16-12 ELECTRICAL SYSTEM

## Wiring Diagram (United States and Canada) ZX600P8F

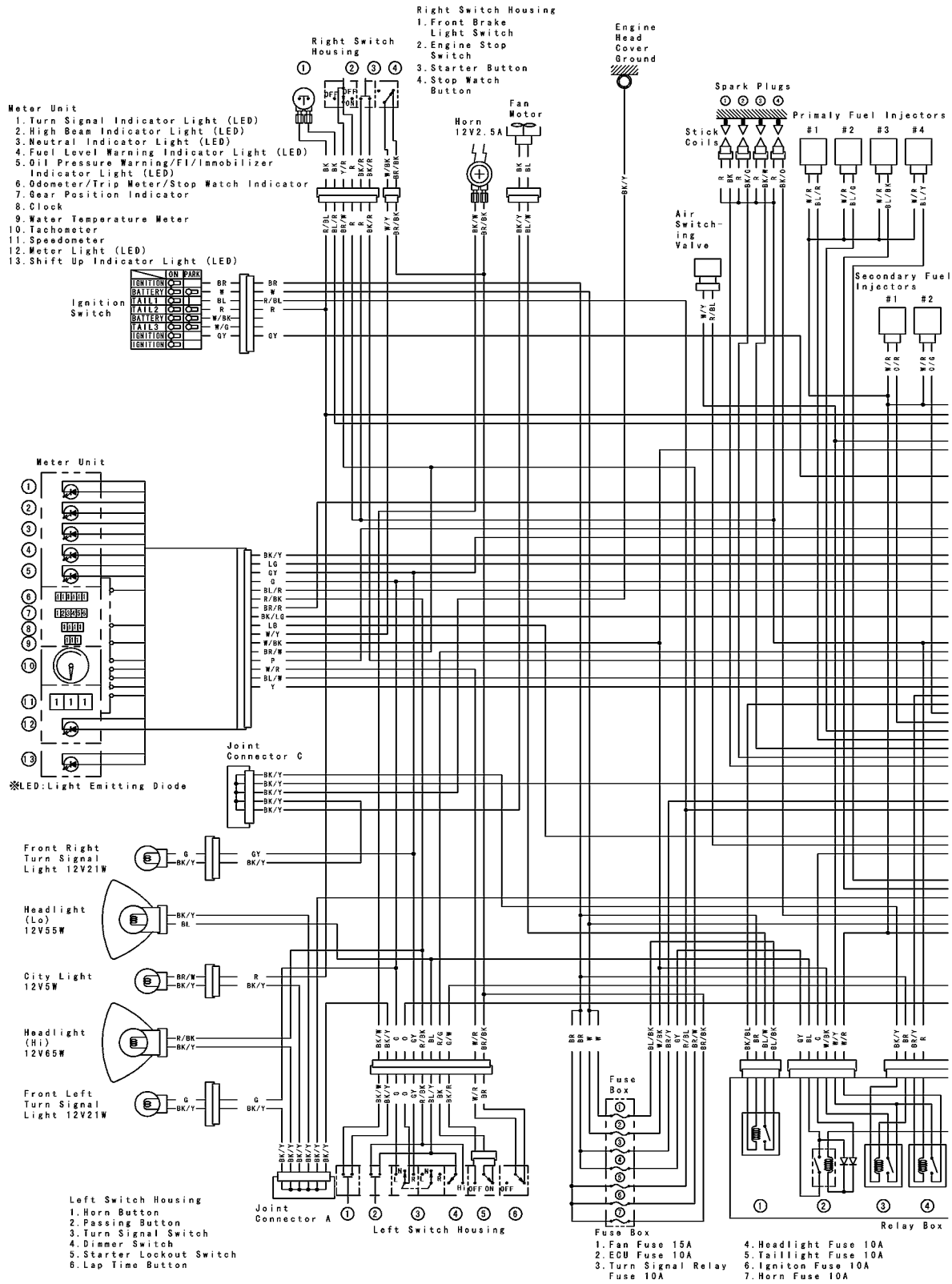

LEFT HANDLEBAR SWITCH CONNECTIONS											
Horn Button	Turn Signal Switch	Dimmer Switch	Starter Lockout Switch	Lap Time Button	Passing Button						
Color BK/W BK/Y	Color G O GY	Color BL/YR/BK	Color BK BK/R	Color W/R BR	Color BL/YR/BK						
Push	L	HI	Clutch Lever	Push	Push						
Released	R	LO	Released	Push	Push						

## Wiring Diagram (United States and Canada) ZX600P8F

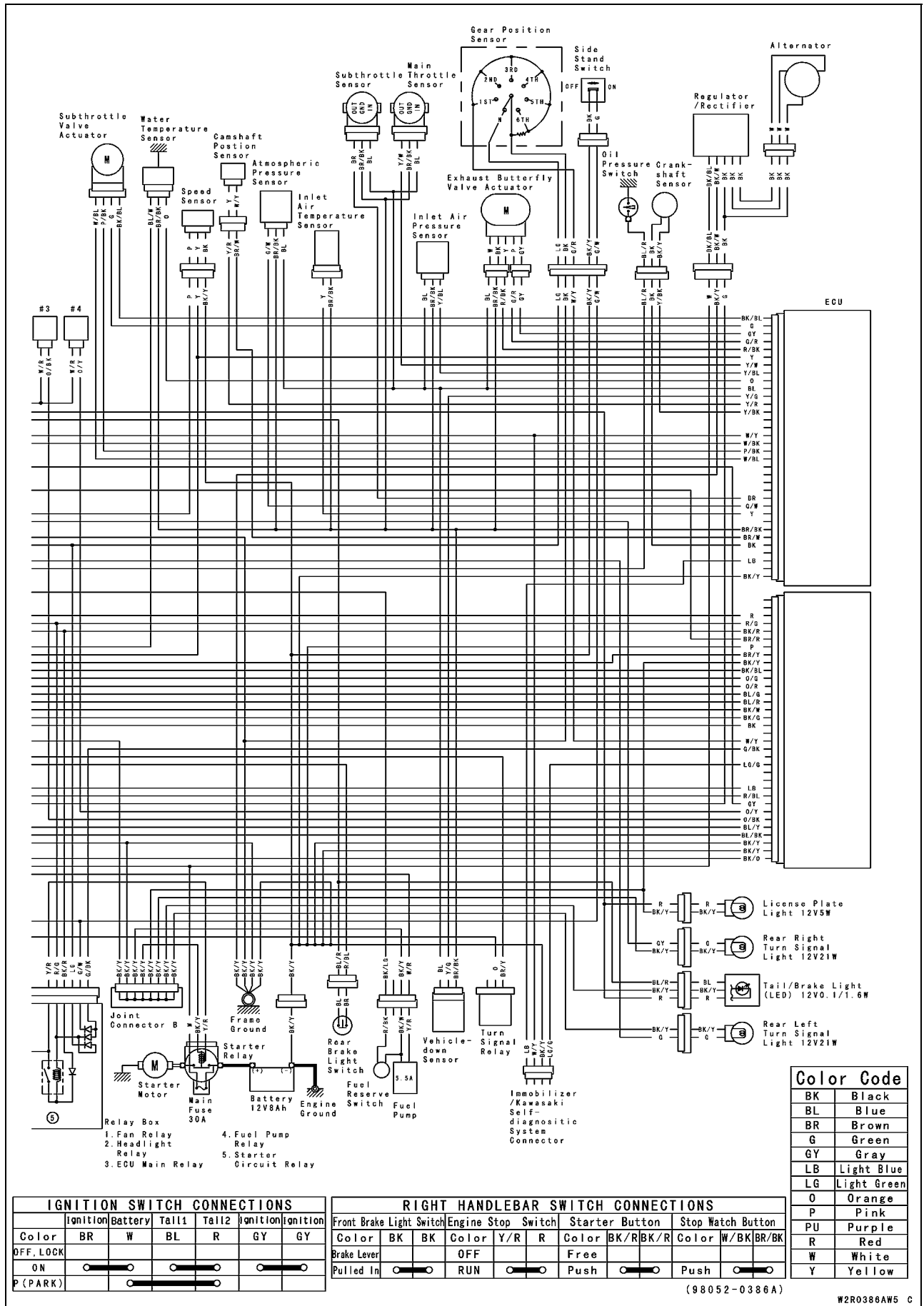

# 16-14 ELECTRICAL SYSTEM

## Wiring Diagram (Other than United States, Canada, Australia and Malaysia) ZX600P7F

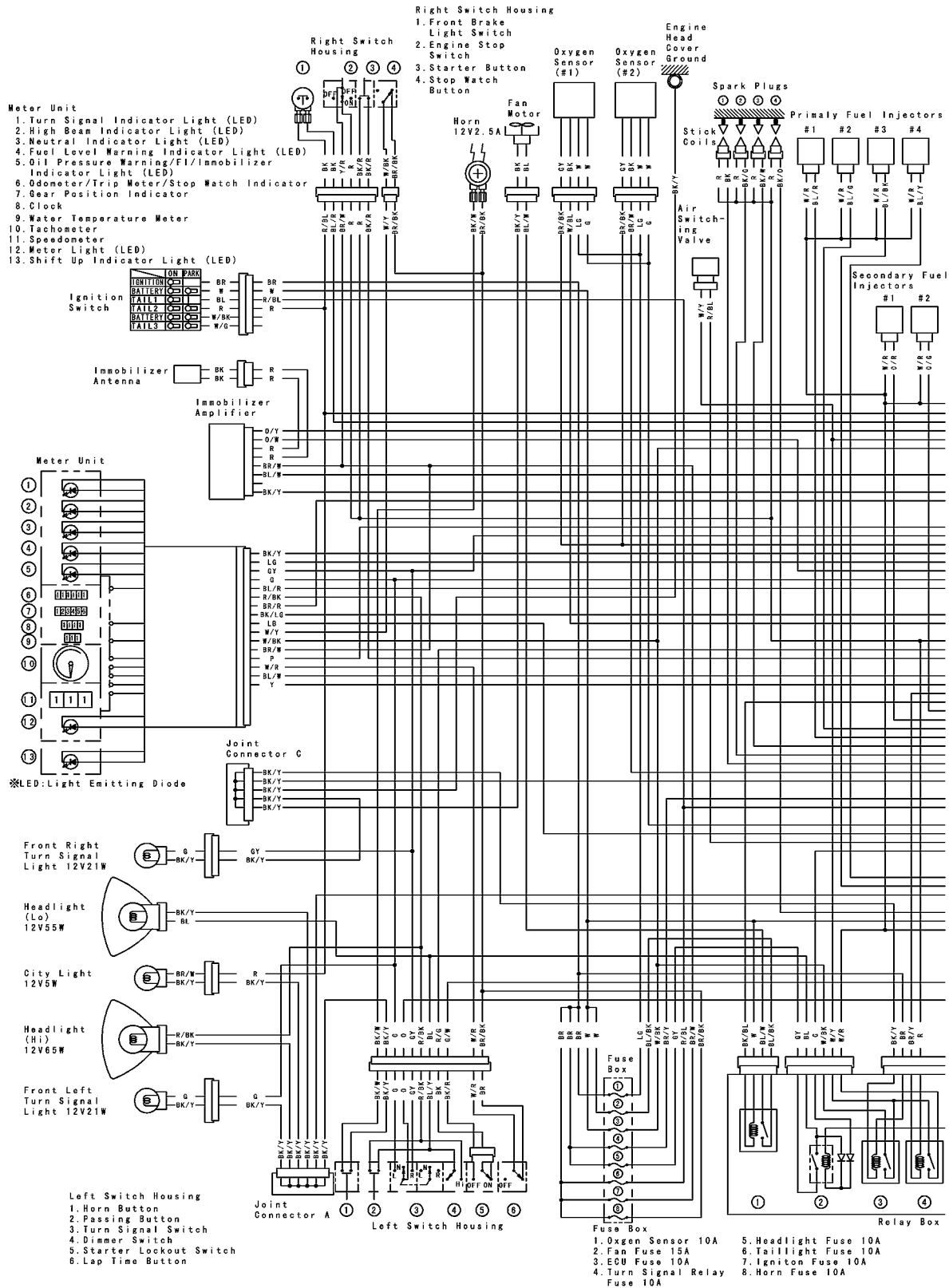

LEFT HANDLEBAR SWITCH CONNECTIONS															
Horn Button	Turn Signal Switch	Dimmer Switch	Starter Lockout Switch	Lap Time Button	Passing Button										
Color	BK/W/BK/Y	Color	G	O	GY	Color	BL/Y/R/BK	Color	BK	BK/R	Color	W/R	BR	Color	BL/Y/R/BK
Push	○	OFF (Push)	○			HI	○	Released			Push	○		Push	○
Released		R	○			L0		Pulled in	○						

# ELECTRICAL SYSTEM 16-15

## Wiring Diagram (Other than United States, Canada, Australia and Malaysia) ZX600P7F

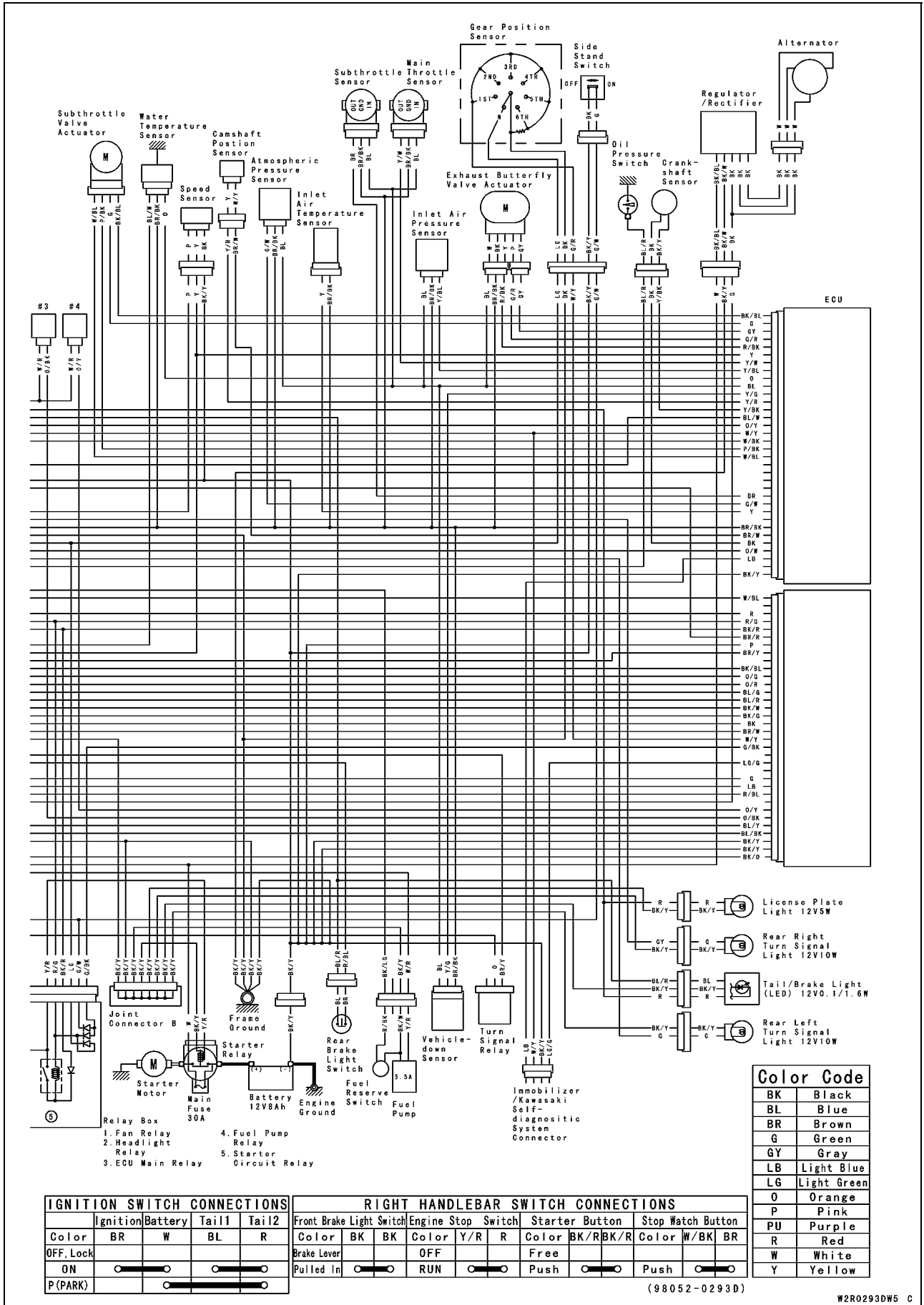

# 16-16 ELECTRICAL SYSTEM

## Wiring Diagram (Other than United States, Canada, Australia and Malaysia) ZX600P8F

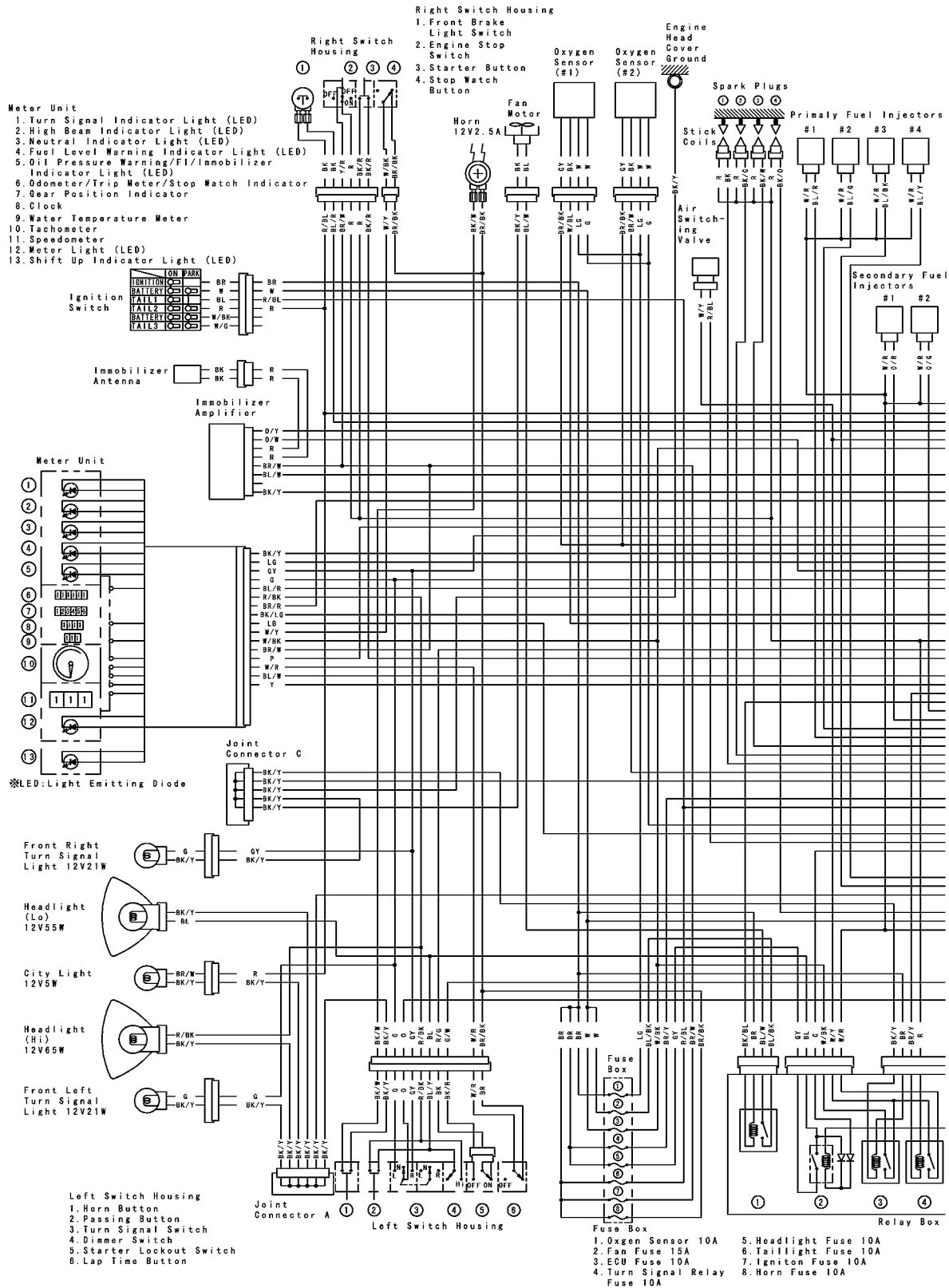

LEFT HANDLEBAR SWITCH CONNECTIONS															
Horn Button	Turn Signal Switch	Dimmer Switch	Starter Lockout Switch	Lap Time Button	Passing Button										
Color	BK/W/BK/Y	Color	G	O	GY	Color	BL/Y/R/BK	Color	BK	BK/R	Color	W/R	BR	Color	BL/Y/R/BK
Push	OFF (Push)		HI			Clutch Lever					Push			Push	
Released	R		LO			Pulled in									



# ELECTRICAL SYSTEM 16-17

## Wiring Diagram (Other than United States, Canada, Australia and Malaysia) ZX600P8F

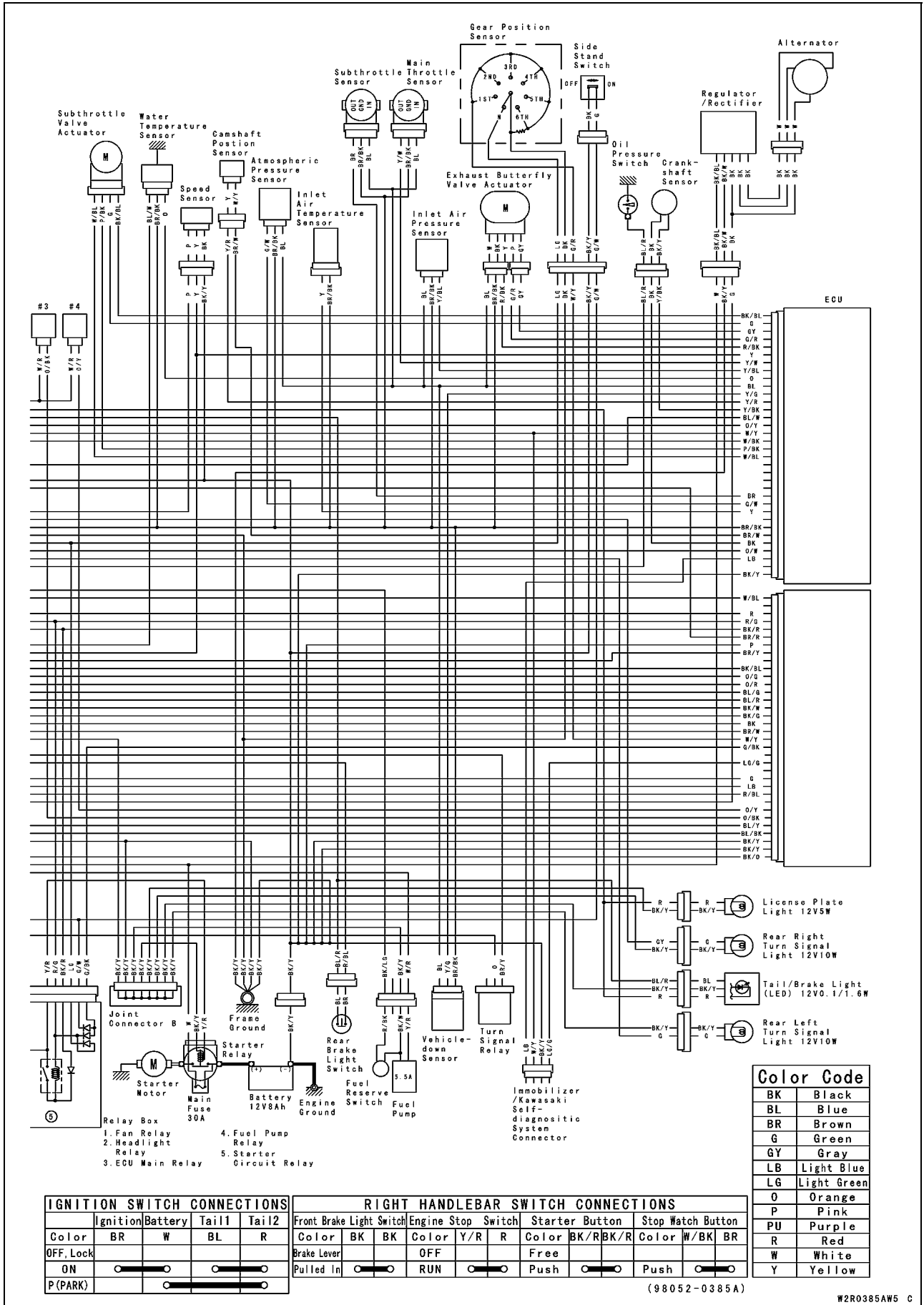

# 16-18 ELECTRICAL SYSTEM

## Wiring Diagram (Australia) ZX600P7F

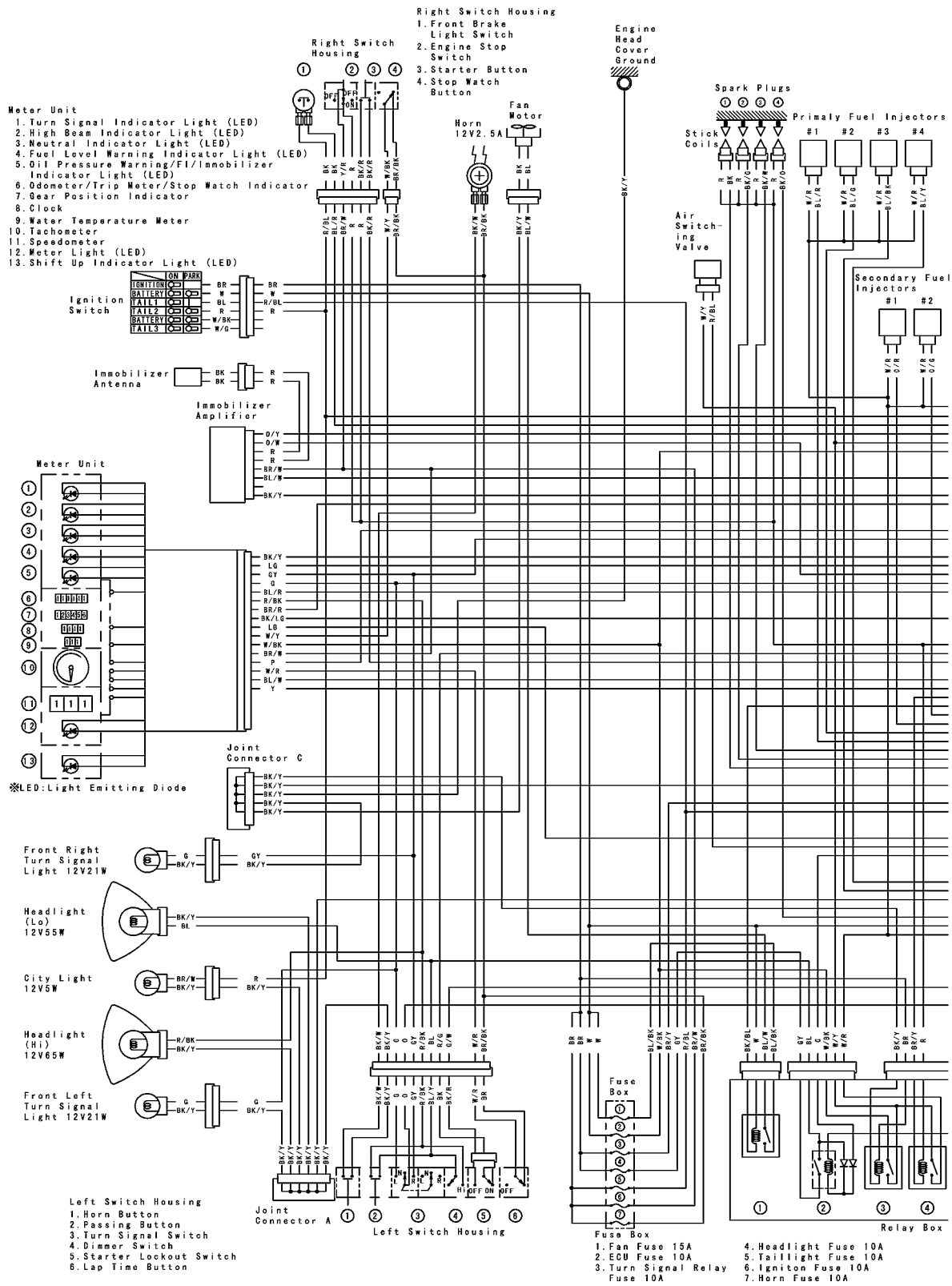

LEFT HANDLEBAR SWITCH CONNECTIONS																
Horn Button	Turn Signal Switch	Dimmer Switch	Starter Lockout Switch	Lap Time Button	Passing Button											
Color	BK/W	BK/Y	Color	G	O	GY	Color	BL/Y/R/BK	Color	BK	BK/R	Color	W/R	BR	Color	BL/Y/R/BK
Push	---	---	---	---	---	---	---	---	---	---	---	---	---	---	---	---
Released	---	---	---	---	---	---	---	---	---	---	---	---	---	---	---	---

## Wiring Diagram (Australia) ZX600P7F

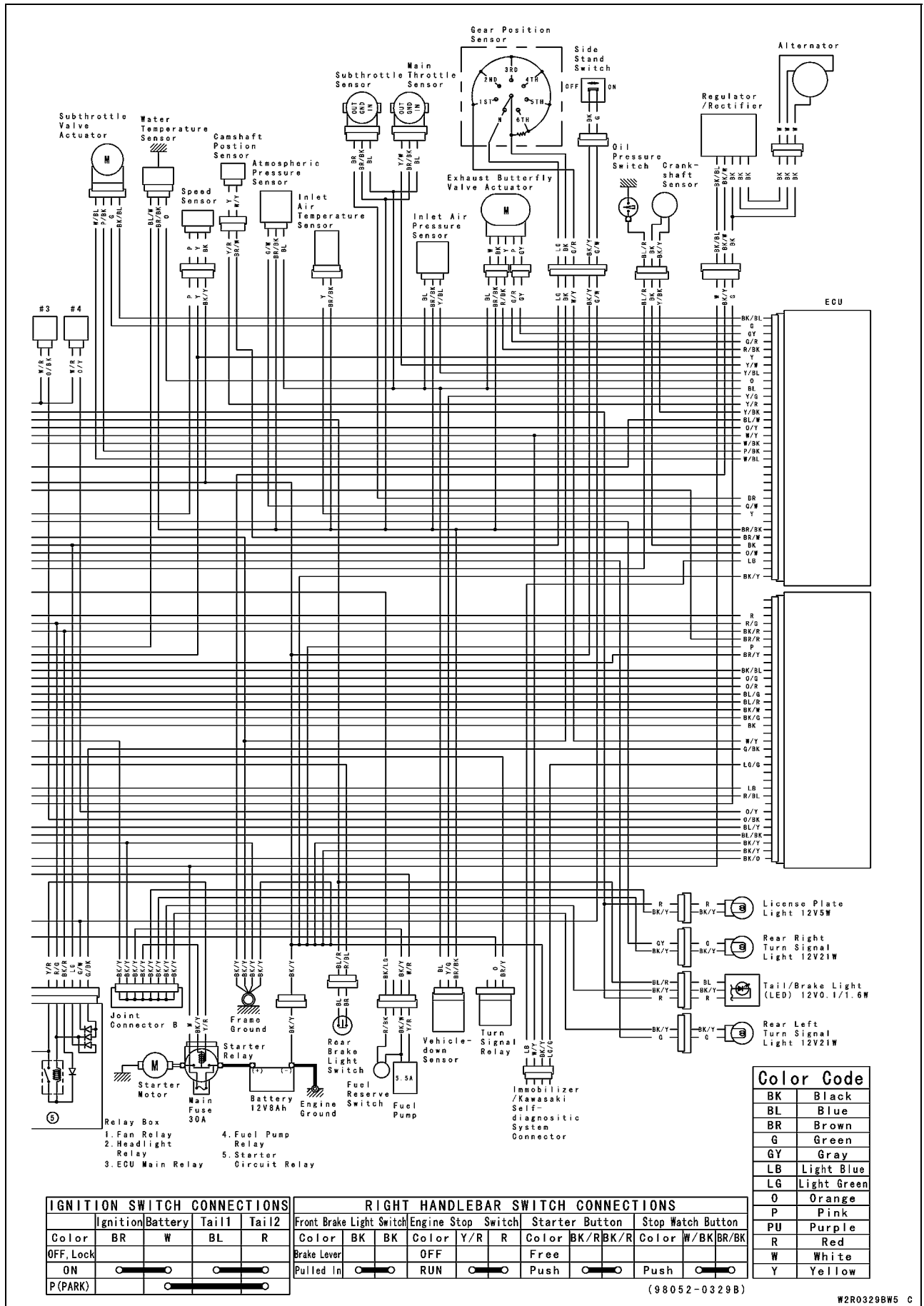

(98052-0329B)

W2R0329BWS C

# 16-20 ELECTRICAL SYSTEM

## Wiring Diagram (Australia) ZX600P8F

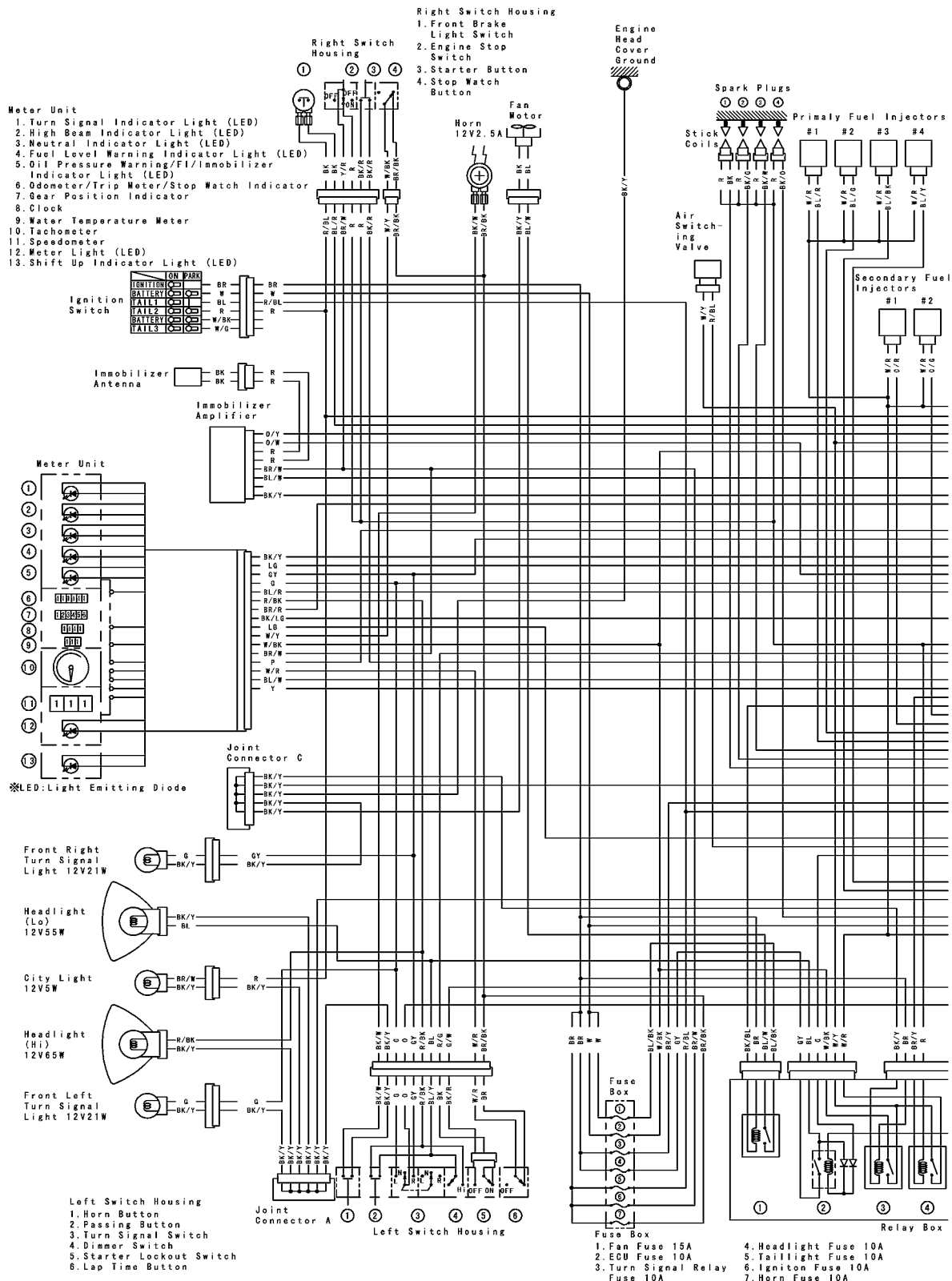

LEFT HANDLEBAR SWITCH CONNECTIONS											
Horn Button	Turn Signal Switch	Dimmer Switch	Starter Lockout Switch	Lap Time Button	Passing Button						
Color BK/W BK/Y	Color G O GY	Color BL/YR/BK	Color BK BK/R	Color W/R BR	Color BL/YR/BK						
Push	L	HI	Clutch Lever	Push	Push						
Released	R	LO	Released								

## Wiring Diagram (Australia) ZX600P8F

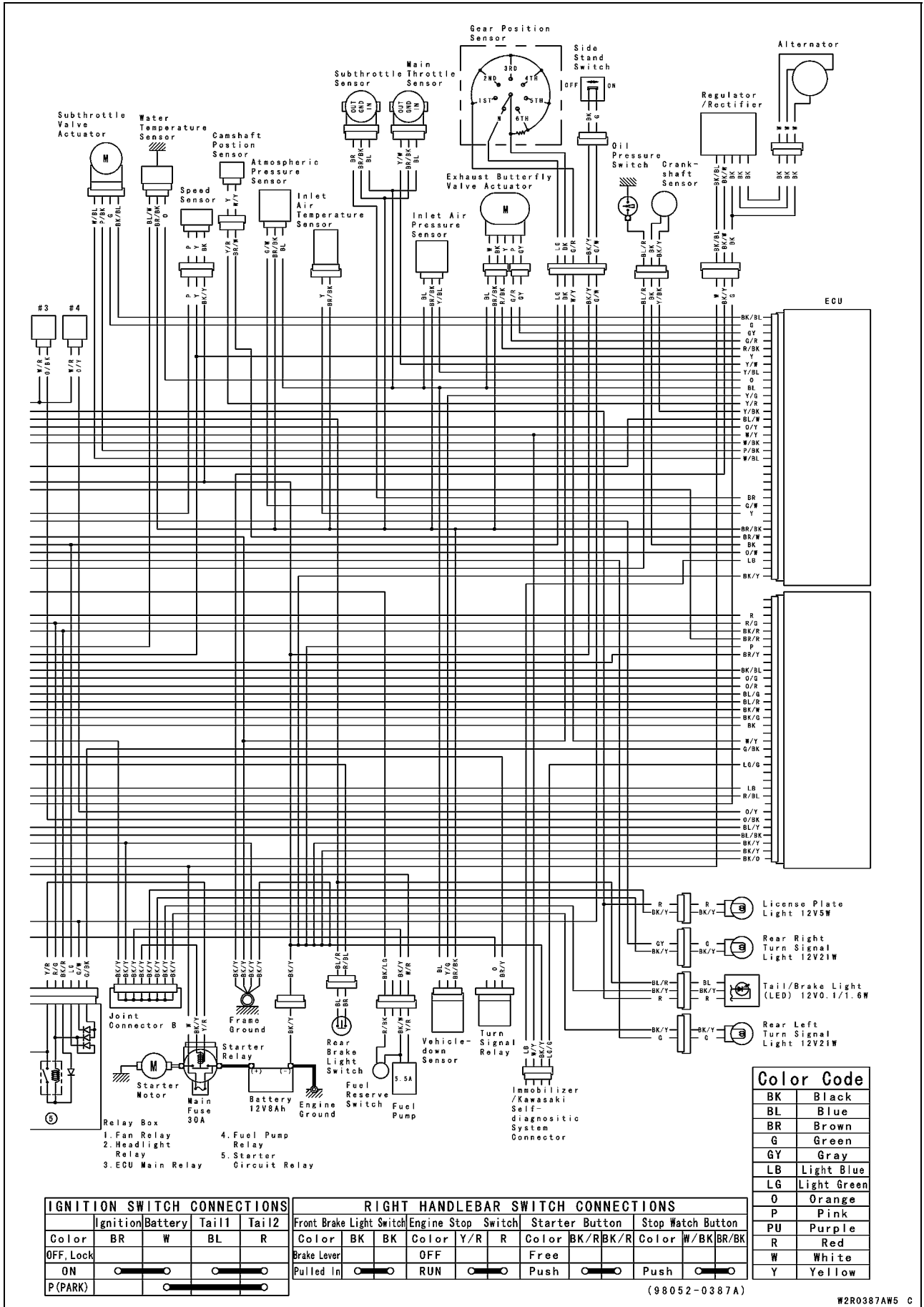

# 16-22 ELECTRICAL SYSTEM

## Wiring Diagram (Malaysia) ZX600P7F

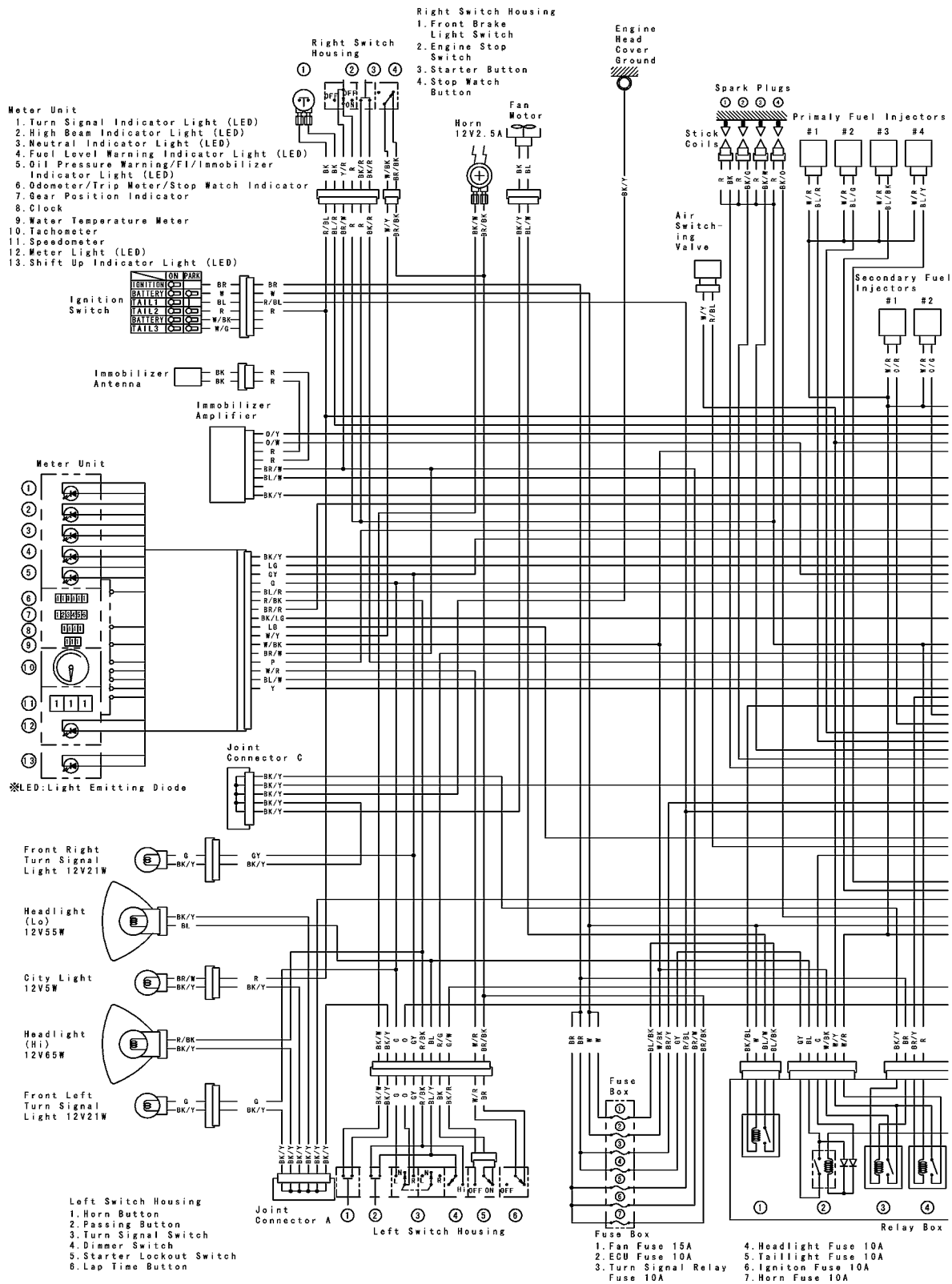

LEFT HANDLEBAR SWITCH CONNECTIONS																		
Horn Button	Turn Signal Switch	Dimmer Switch	Starter Lockout Switch	Lap Time Button	Passing Button													
Color	BK/W	BK/Y	Color	G	O	GY	Color	BL/Y	R/BK	Color	BK	BK/R	Color	W/R	BR	Color	BL/Y	R/BK
Push		L					HI			Released			Push			Push		
Released		R					LO			Pulled in								

Wiring Diagram (Malaysia) ZX600P7F

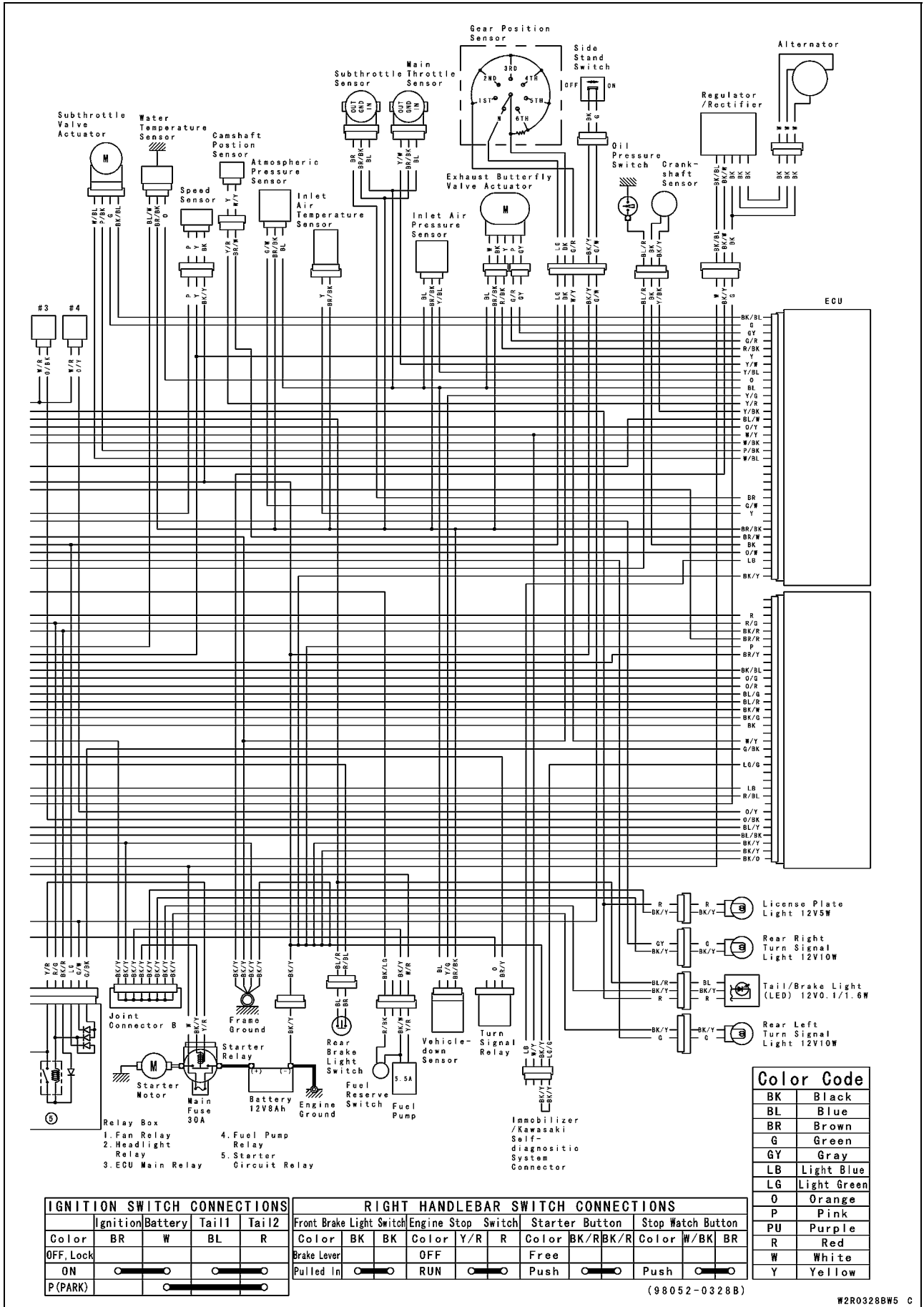

# 16-24 ELECTRICAL SYSTEM

## Wiring Diagram (Malaysia) ZX600P8F

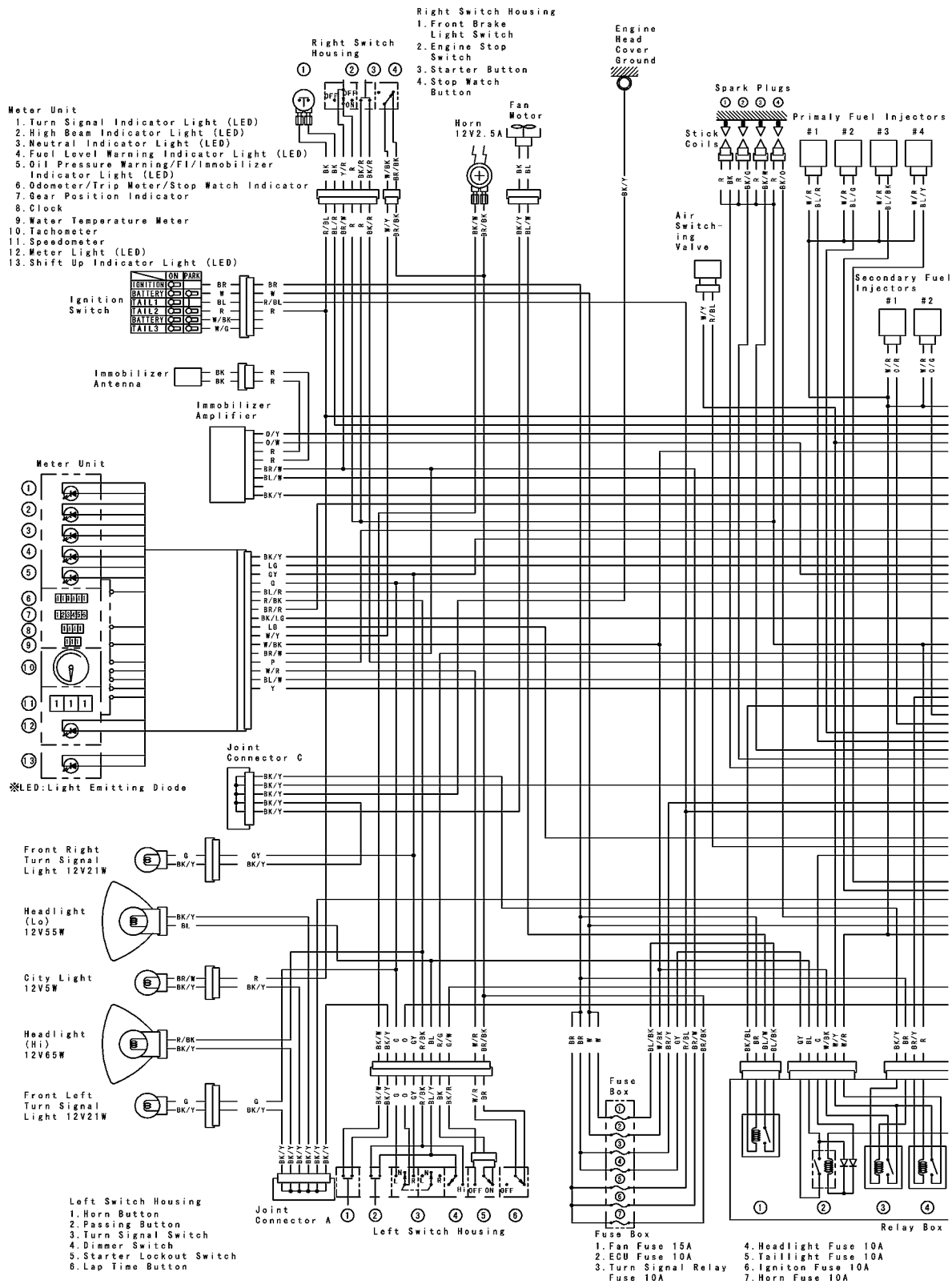

LEFT HANDLEBAR SWITCH CONNECTIONS											
Horn Button	Turn Signal Switch	Dimmer Switch	Starter Lockout Switch	Lap Time Button	Passing Button						
Color BK/W BK/Y	Color G O GY	Color BL/YR/BK	Color BK BK/R	Color W/R BR	Color BL/YR/BK						
Push	L	HI	Clutch Lever	Push	Push						
Released	R	LO	Released	Released	Released						



## Wiring Diagram (Malaysia) ZX600P8F

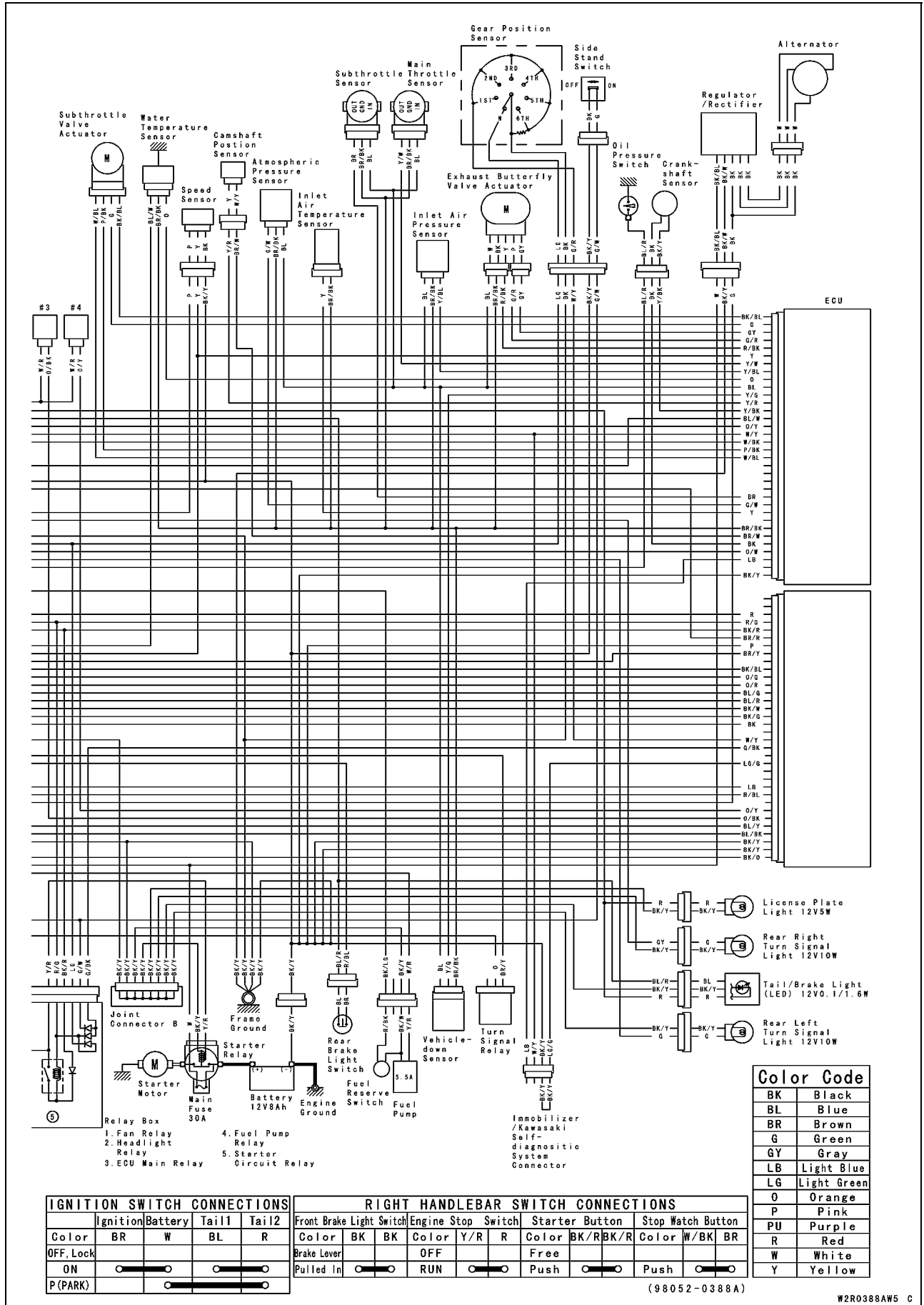

## 16-26 ELECTRICAL SYSTEM

### Specifications

Item	Standard
<b>Battery</b>	
Type	Sealed battery
Capacity	12 V 8 Ah
Voltage	12.8 V or more
<b>Charging System</b>	
Type	Three-phase AC
Alternator Output Voltage	42 V or more @4 000 r/min (rpm)
Stator Coil Resistance	0.1 ~ 0.3 $\Omega$
Charging Voltage (Regulator/rectifier Output Voltage)	14.2 ~ 15.0 V
Regulator/Rectifier Resistance	in the text
<b>Ignition System</b>	
Crankshaft Sensor Resistance	380 ~ 570 $\Omega$
Crankshaft Sensor Peak Voltage	3.2 V or more
Camshaft Position Sensor Resistance	400 ~ 460 $\Omega$
Camshaft Position Sensor Peak Voltage	0.4 V or more
Spark Plug Gap	0.7 ~ 0.8 mm (0.028 ~ 0.032 in.)
Stick Coil:	
Primary Winding Resistance	1.2 ~ 1.6 $\Omega$
Secondary Winding Resistance	8.5 ~ 11.5 k $\Omega$
Primary Peak Voltage	80 V or more
<b>Electric Starter System</b>	
Starter Motor:	
Brush Length	7 mm (0.28 in.), Service Limit: 3.5 mm (0.14 in.)
Commutator Diameter	24 mm (0.94 in.), Service Limit: 23 mm (0.91 in.)
<b>Air Switching Valve</b>	
Air Switching Valve Resistance	12 ~ 22 $\Omega$ at 20°C (68°F)
<b>Switch and Sensor</b>	
Rear Brake Light Switch Timing	ON after about 10 mm (0.39 in.) pedal travel
Engine Oil Pressure Switch Connections	When engine is stopped: ON When engine is running: OFF
Water Temperature Sensor Resistance	In the text

Special Tools and Sealant

Hand Tester:  
57001-1394

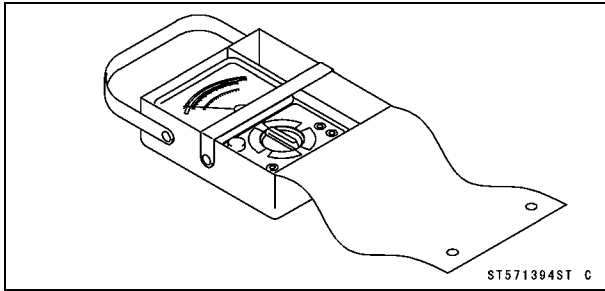

Flywheel Puller Assembly, M38 x 1.5/M35 x 1.5:  
57001-1405

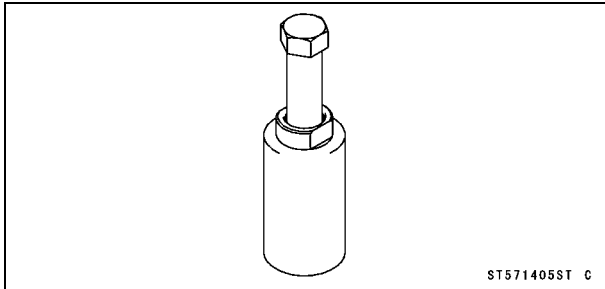

Peak Voltage Adapter:  
57001-1415

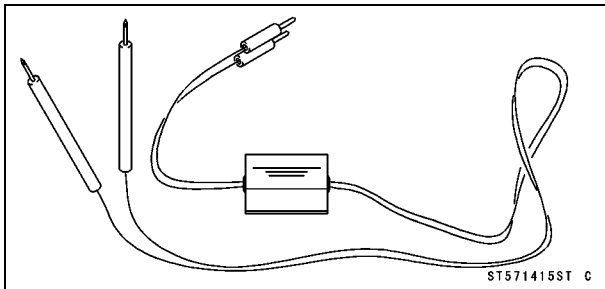

Lead Wire - Peak Voltage Adapter:  
57001-1449

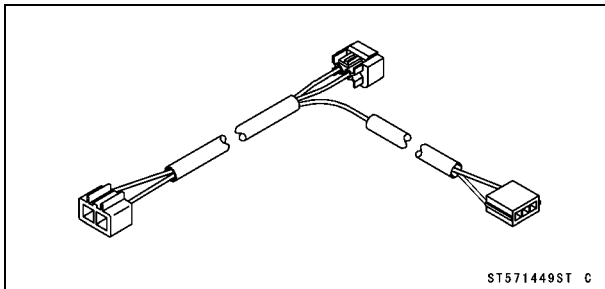

Key Registration Unit:  
57001-1582

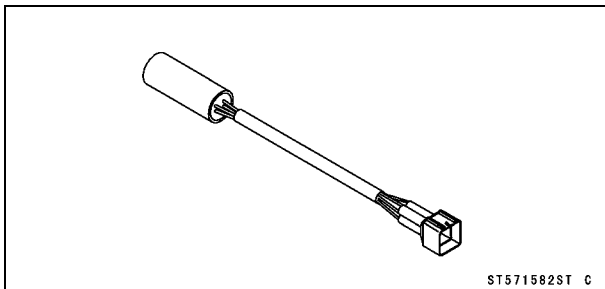

Grip:  
57001-1591

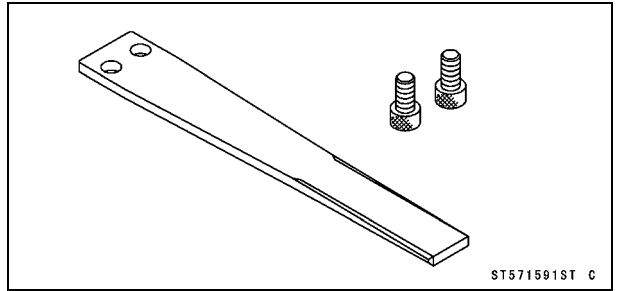

Rotor Holder:  
57001-1666

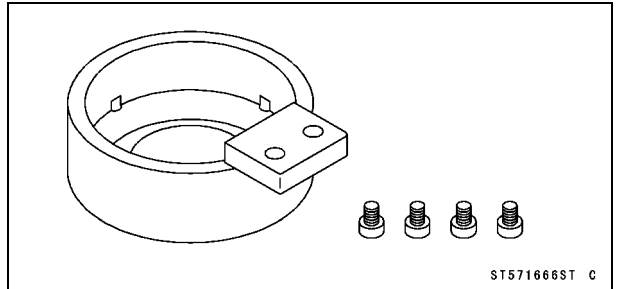

Stopper:  
57001-1679

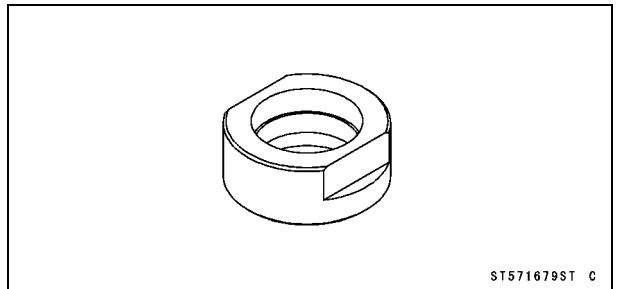

Rotor Holder Attachment:  
57001-1689

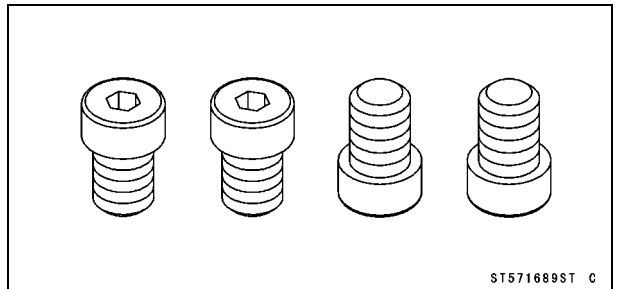

Kawasaki Bond (Silicone Sealant):  
92104-0004

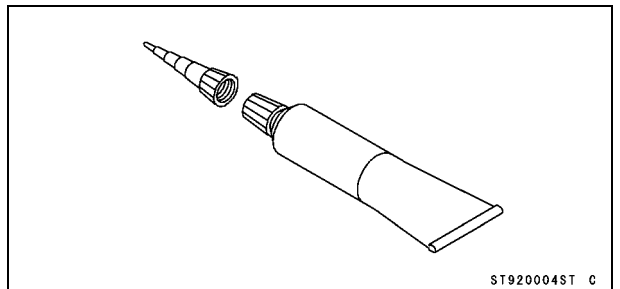

## 16-28 ELECTRICAL SYSTEM

---

### Precautions

---

There are a number of important precautions that are musts when servicing electrical systems. Learn and observe all the rules below.

- Do not reverse the battery cable connection. This will burn out the diodes on the electrical parts.
- Always check battery condition before condemning other parts of an electrical system. A fully charged battery is a must for conducting accurate electrical system tests.
- The electrical parts should never be struck sharply, as with a hammer, or allowed to fall on a hard surface. Such a shock to the parts can damage them.
- To prevent damage to electrical parts, do not disconnect the battery cables or any other electrical connections when the ignition switch is on, or while the engine is running.
- Because of the large amount of current, never keep the starter button pushed when the starter motor will not turn over, or the current may burn out the starter motor windings.
- Take care not to short the cables that are directly connected to the battery positive (+) terminal to the chassis ground.
- Troubles may involve one or in some cases all items. Never replace a defective part without determining what CAUSED the failure. If the failure was caused by some other item or items, they must be repaired or replaced, or the new replacement will soon fail again.
- Make sure all connectors in the circuit are clean and tight, and examine wires for signs of burning, fraying, etc. Poor wires and bad connections will affect electrical system operation.
- Measure coil and winding resistance when the part is cold (at room temperature).
- Color Codes:

BK: Black	G: Green	P: Pink
BL: Blue	GY: Gray	PU: Purple
BR: Brown	LB: Light Blue	R: Red
CH: Chocolate	LG: Light Green	W: White
DG: Dark Green	O: Orange	Y: Yellow

## Electrical Wiring

### Wiring Inspection

- Visually inspect the wiring for signs of burning, fraying, etc.
- ★ If any wiring is poor, replace the damaged wiring.
- Pull each connector [A] apart and inspect it for corrosion, dirt, and damage.
- ★ If the connector is corroded or dirty, clean it carefully. If it is damaged, replace it.
- Check the wiring for continuity.
- Use the wiring diagram to find the ends of the lead which is suspected of being a problem.
- Connect the hand tester between the ends of the leads.

#### Special Tool - Hand Tester: 57001-1394

- Set the tester to the  $\times 1 \Omega$  range, and read the tester.
- ★ If the tester does not read  $0 \Omega$ , the lead is defective. Replace the lead or the wiring harness [B] if necessary.

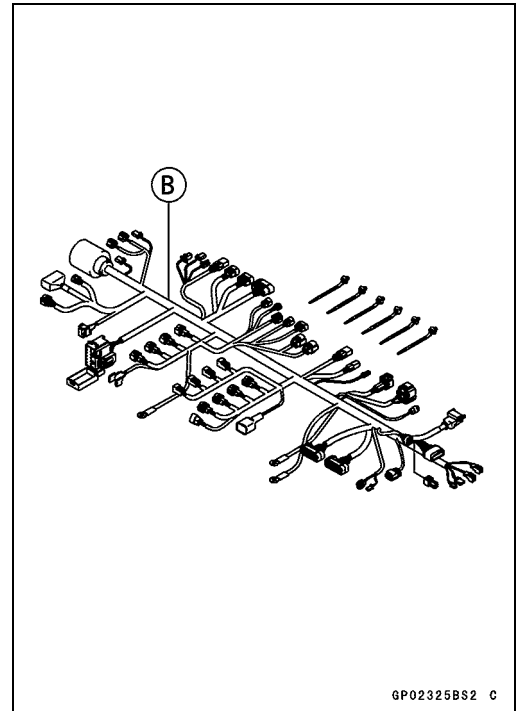
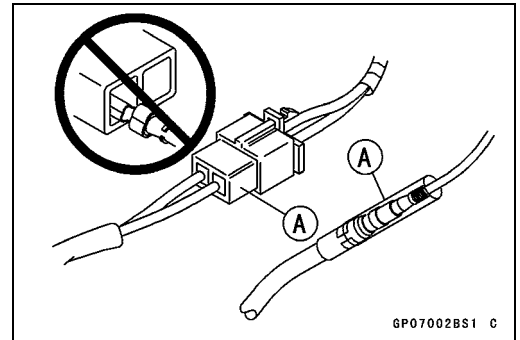

# 16-30 ELECTRICAL SYSTEM

## Battery

### Battery Removal

- Remove:
  - Side Covers (see Side Cover Removal in the Frame chapter)
  - Front Seat (see Front Seat Removal in the Frame chapter)
- Slide the caps [A].
- Disconnect the negative (-) cable [B] and then positive (+) cable [C].

#### CAUTION

Be sure to disconnect the negative (-) cable first.

- Remove the band [D].
- Remove the battery.

### Battery Installation

- Visually inspect the surface of the battery container.
- ★ If any signs of cracking or electrolyte leakage from the sides of the battery.
- Put the battery into the battery case.
- Install the fuel tank bracket and connector.
- Connect the positive cable [A] (red cap) to the (+) terminal first, and then the negative cable (black cap) [B] to the (-) terminal.
- Apply a light coat of grease on the terminals to prevent corrosion.
- Cover the terminals with the caps [C].

#### CAUTION

If each battery cable is not correctly disconnected or connected, sparks can arise at electrical connections, causing damage to electrical and DFI parts.

### Battery Activation

#### Electrolyte Filling

- Make sure that the model name [A] of the electrolyte container matches the model name [B] of the battery. These names must be the same.

Battery Model Name for ZX600P7F: YTX9-BS

#### CAUTION

Be sure to use the electrolyte container with the same model name as the battery since the electrolyte volume and specific gravity vary with the battery type. This is to prevent overfilling of the electrolyte, shorting the battery life, and deterioration of the battery performance.

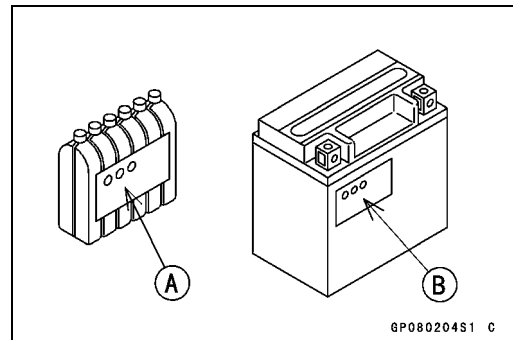
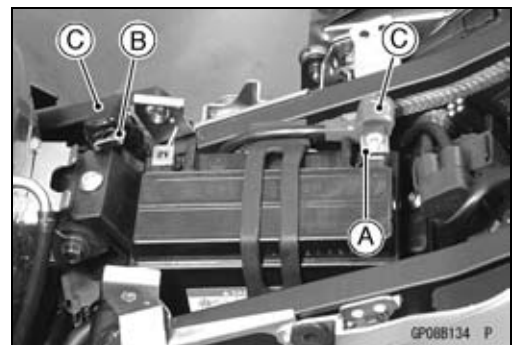
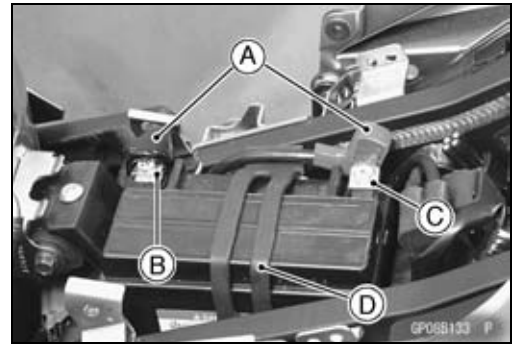

## Battery

**CAUTION**

**Do not remove the aluminum sealing sheet [A] from the filler ports [B] until just prior to use. Be sure to use the dedicated electrolyte container for correct electrolyte volume.**

- Place the battery on a level surface.
- Check to see that the sealing sheet has no peeling, tears, or holes in it.
- Remove the sealing sheet.

**NOTE**

○ *The battery is vacuum sealed. If the sealing sheet has leaked air into the battery, it may require a longer initial charge.*

- Remove the electrolyte container from the vinyl bag.
- Detach the strip of caps [A] from the container and set aside, these will be used later to seal the battery.

**NOTE**

○ *Do not pierce or otherwise open the sealed cells [B] of the electrolyte container. Do not attempt to separate individual cells.*

- Place the electrolyte container upside down with the six sealed cells into the filler ports of the battery. Hold the container level, push down to break the seals of all six cells. You will see air bubbles rising into each cell as the ports fill.

**NOTE**

○ *Do not tilt the electrolyte container*

- Check the electrolyte flow.
- ★ If no air bubbles [A] are coming up from the filler ports, or if the container cells have not emptied completely, tap the container [B] a few times.
- Keep the container in place for **20** minutes or more. Don't remove the container from the battery until it's empty, the battery requires all the electrolyte from the container for proper operation.

**CAUTION**

**Removal of the container before it is completely empty can shorten the service life of the battery. Do not remove the electrolyte container until it is completely empty and 20 minutes have elapsed.**

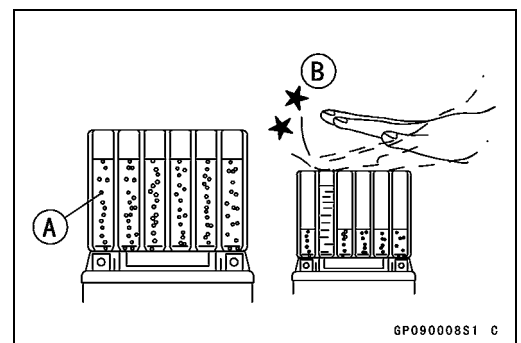
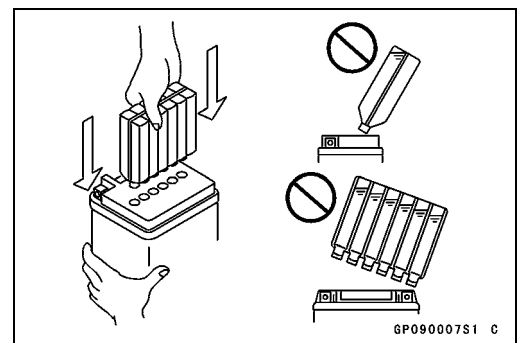
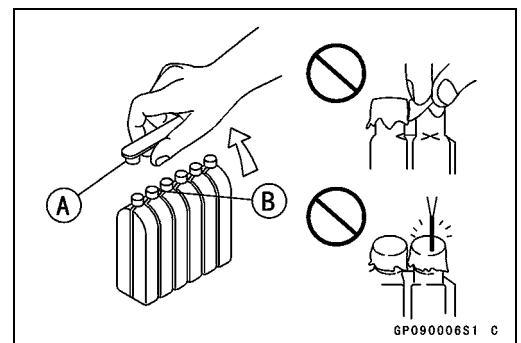
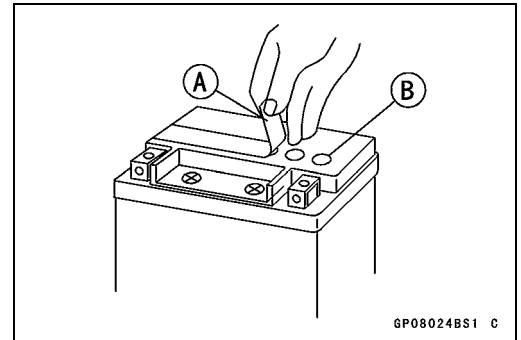

# 16-32 ELECTRICAL SYSTEM

## Battery

- Gently remove the container from the battery.
- Let the battery sit for **30** minutes prior to charging to allow the electrolyte to permeate into the plates for optimum performance.

### NOTE

○Charging the battery immediately after filling can shorten service life. Let the battery sit for at least **30** minutes after filling.

### Initial Charge

- Place the strip [A] of caps loosely over the filler ports.
- Newly activated sealed batteries require an initial charge.

**Standard Charge: 0.9 A × 5 ~ 10 hours**

★If using a recommended battery charger, follow the charger's instructions for newly activated sealed battery.

#### Kawasaki-recommended chargers

**Optimate III**

**Yuasa 1.5 Amp Automatic Charger**

**Battery Mate 150-9**

★If the above chargers are not available, use equivalent one.

### NOTE

○Charging rates will vary depending on how long the battery has been stored, temperature, and the type of charger used. Let battery sit 30 minutes after initial charge, then check voltage using a voltmeter. If it is not at least 12.8 V, repeat charging cycle.

- After charging is completed, press down firmly with both hands to seat the strip of caps [A] into the battery (don't pound or hammer). When properly installed, the strip of the caps will be level with the top of the battery.

### CAUTION

Once the strip of the caps [A] is installed onto the battery, never remove the caps, nor add water or electrolyte to the battery.

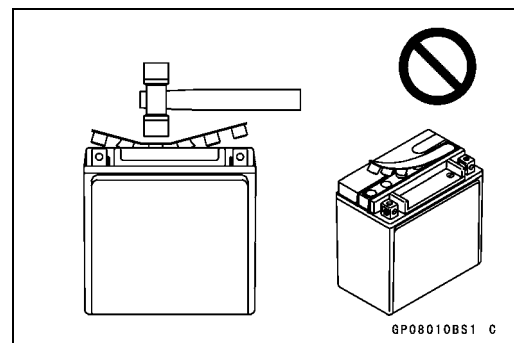
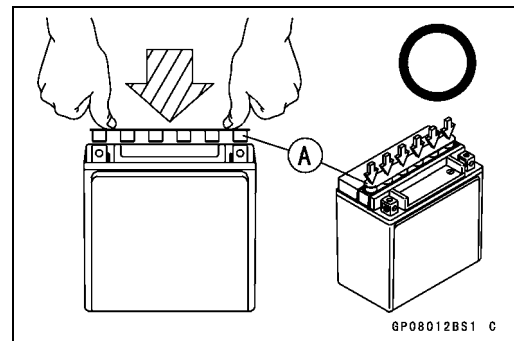
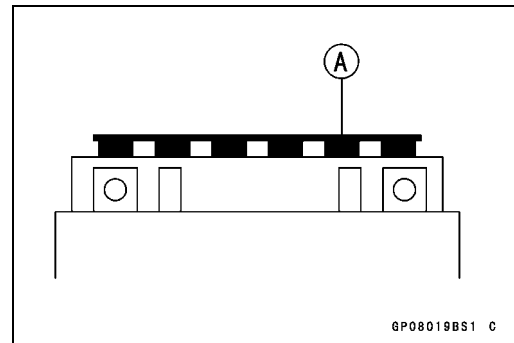



## Battery

### NOTE

○ To ensure maximum battery life and customer satisfaction, it is recommended the battery be load tested at three times its amp-hour rating for 15 seconds.

Re-check voltage and if less than 12.8 V repeat the charging cycle and load test. If still below 12.8 V the battery is defective.

### Precautions

- 1) No need of topping-up

No topping-up is necessary in this battery until it ends its life under normal use. Forcibly prying off the seal cap to add water is very dangerous. Never do that.

- 2) Refreshing charge.

If an engine will not start, a horn sounds weak, or lamps are dim, it indicates the battery has been discharged. Give refresh charge for 5 to 10 hours with charge current shown in the specification (see Specifications in this chapter).

When a fast charge is inevitably required, do it following precisely the maximum charge current and time conditions indicated on the battery.

### CAUTION

**This battery is designed to sustain no unusual deterioration if refresh-charged according to the method specified above. However, the battery's performance may be reduced noticeably if charged under conditions other than given above. Never remove the seal cap during refresh charge.**

**If by chance an excessive amount of gas is generated due to overcharging, the relief valve releases the gas to keep the battery normal.**

- 3) When you do not use the motorcycle for months.

Give a refresh charge before you store the motorcycle and store it with the negative cable removed. Give a refresh charge **once a month** during storage.

- 4) Battery life.

If the battery will not start the engine even after several refresh charges, the battery has exceeded its useful life. Replace it (Provided, however, the vehicle's starting system has no problem).

### ⚠ WARNING

**Keep the battery away from sparks and open flames during charging, since the battery gives off an explosive gas mixture of hydrogen and oxygen. When using a battery charger, connect the battery to the charger before turning on the charger.**

**This procedure prevents sparks at the battery terminals which could ignite any battery gases.**

**No fire should be drawn near the battery, or no terminals should have the tightening loosened.**

**The electrolyte contains sulfuric acid. Be careful not to have it touch your skin or eyes. If touched, wash it off with liberal amount of water. Get medical attention if severe.**

### Interchange

A sealed battery can fully display its performance only when combined with a proper vehicle electric system. Therefore, replace a sealed battery only on a motorcycle which was originally equipped with a sealed battery.

Be careful, if a sealed battery is installed on a motorcycle which had an ordinary battery as original equipment, the sealed battery's life will be shortened.

# 16-34 ELECTRICAL SYSTEM

## Battery

### Charging Condition Inspection

- Battery charging condition can be checked by measuring battery terminal voltage with a digital voltmeter [A].
- Remove:
  - Fuel Tank (see Fuel Tank Removal in the Fuel System (DFI) chapter)
  - Battery Cable Caps (see Battery Removal in this chapter)
- Disconnect the battery terminals.

### CAUTION

Be sure to disconnect the negative (–) cable first.

- Measure the battery terminal voltage.

### NOTE

○ Measure with a digital voltmeter which can be read one decimal place voltage.

- ★ If the reading is 12.8 V or more, no refresh charge is required, however, if the read is below the specified, refresh charge is required.

### Battery Terminal Voltage

Standard: 12.8 V or more

Terminal Voltage (V) [A]

Battery Charge Rate (%) [B]

Good [C]

Refresh charge is required [D]

### Refreshing Charge

- Remove the battery [A] (see Battery Removal in this chapter).
- Do refresh charge by following method according to the battery terminal voltage.

### WARNING

This battery is sealed type. Never remove sealing cap [B] even at charging. Never add water. Charge with current and time as stated below.

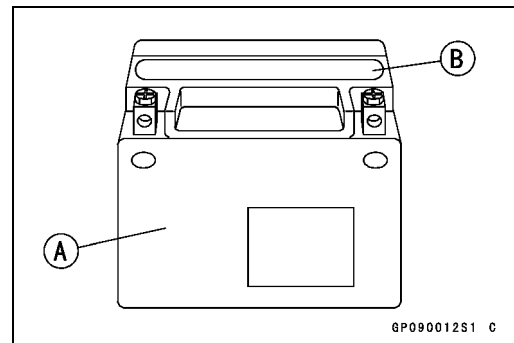
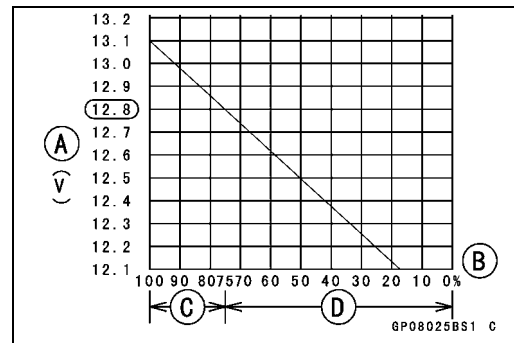
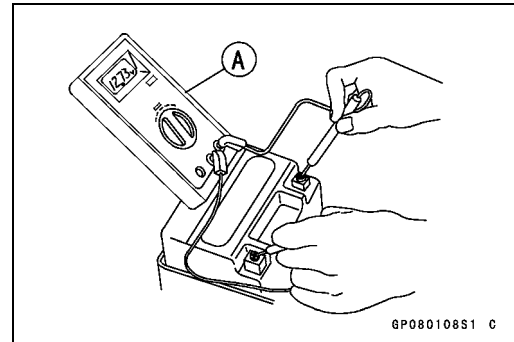

**Battery**

Terminal Voltage: 11.5 ~ less than 12.8 V  
 Standard Charge 0.9 A x 5 ~ 10 h (see following chart)  
 Quick Charge 4 A x 1 h

**CAUTION**

**If possible, do not quick charge. If quick charge is done unavoidably, do standard charge later on.**

Terminal Voltage: less than 11.5 V  
 Charging Method: 0.9 A x 20 h

**NOTE**

○ Increase the charging voltage to a maximum voltage of 25 V if the battery will not accept current initially. Charge for no more than 5 minutes at the increased voltage then check if the battery is drawing current. If the battery will accept current decrease the voltage and charge by the standard charging method described on the battery case. If the battery will not accept current after 5 minutes, replace the battery.

Battery [A]  
 Battery Charger [B]  
 Standard Value [C]  
 Current starts to flow [D]

- Determine the battery condition after refresh charge.
- Determine the condition of the battery left for 30 minutes after completion of the charge by measuring the terminal voltage according to the table below.

Criteria	Judgement
12.8 V or higher	Good
12.0 ~ lower than 12.8 V	Charge insufficient → Recharge
lower than 12.0 V	Unserviceable → Replace

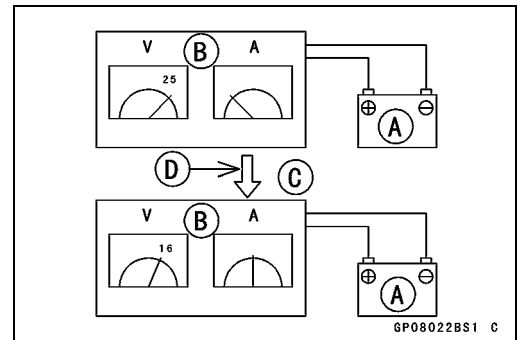
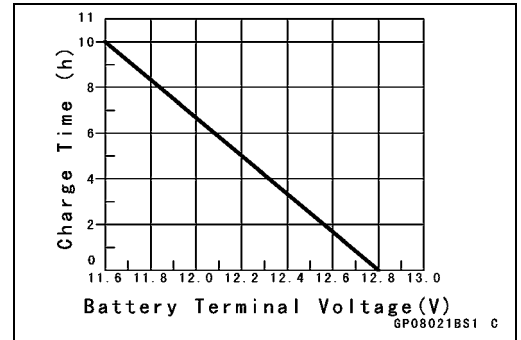

## 16-36 ELECTRICAL SYSTEM

### Charging System

#### Alternator Cover Removal

- Remove:
  - Left Middle Fairing (see Middle Fairing Removal in the Frame chapter)
- Set up the Fuel Tank (see Speed Sensor Removal).
  - Alternator Lead Connector [A]
  - Clamp [B]

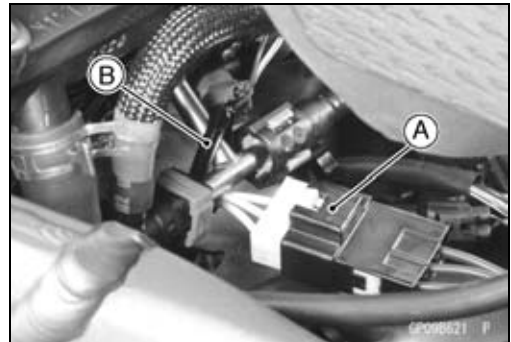

- Remove:
  - Heat Insulation Cover [A]
  - Bolts [B]
  - Cover [C]

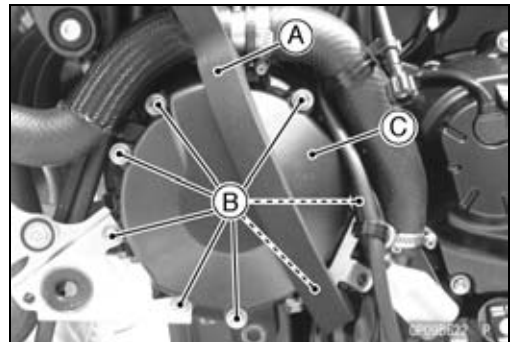

#### Alternator Cover Installation

- Apply silicone sealant to the alternator lead grommet and crankcase halves mating surface [A] on the front and rear sides of the cover mount.

**Sealant - Kawasaki Bond (Silicone Sealant): 92104-0004**

- Check that dowel pins [B] are in place on the crankcase.

- Install:
  - New Gasket
  - Alternator Cover
  - Brackets

- Tighten:

**Torque - Alternator Cover Bolts: 12 N·m (1.2 kgf·m, 106 in·lb)**

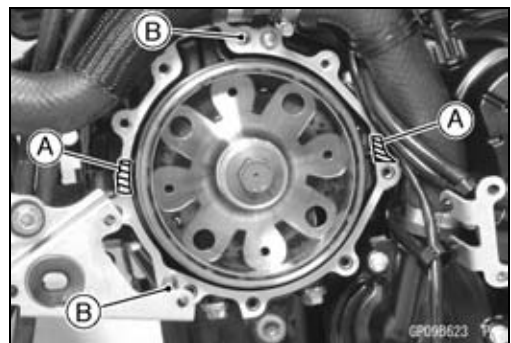

#### Stator Coil Removal

- Remove:
  - Alternator Cover (see Alternator Cover Removal)
  - Stator Coil Bolts [A]
  - Holding Plate Bolts [B] and Plate [C]
  - Alternator Lead Grommet [D]
- Remove the stator coil [E] from the alternator cover.

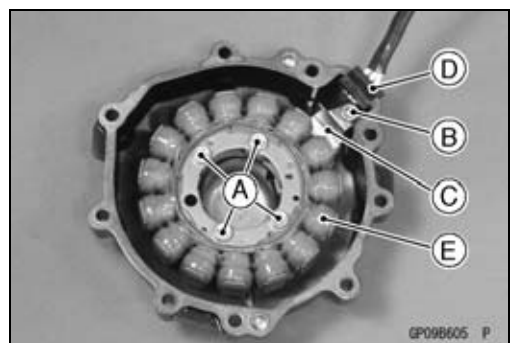

## Charging System

### Stator Coil Installation

- Apply a non-permanent locking agent to the threads of the stator coil bolts and tighten them.

**Torque - Stator Coil Bolts: 12 N·m (1.2 kgf·m, 106 in·lb)**

- Apply silicone sealant to the circumference of the alternator lead grommet, and fit the grommet into the notch of the cover securely.

**Sealant - Kawasaki Bond (Silicone Sealant): 92104-0004**

- Secure the alternator lead with a holding plate, and apply a non-permanent locking agent to the threads of the plate bolts and tighten them.

**Torque - Alternator Lead Holding Plate Bolts: 6.9 N·m (0.70 kgf·m, 61 in·lb)**

- Install the alternator cover (see Alternator Cover Installation).

### Alternator Rotor Removal

- Remove:
  - Alternator Cover (see Alternator Cover Removal)
  - Starter Idle Gear and Shaft
- Wipe oil off the outer circumference of the rotor.
- Hold the alternator rotor steady with the rotor holder [A], and remove the rotor bolt [B].

**Special Tools - Grip [C]: 57001-1591**

**Rotor Holder: 57001-1666**

**Stopper [D]: 57001-1679**

**Rotor Holder Attachment: 57001-1689**

- Using the flywheel puller [A], remove the alternator rotor from the crankshaft.

**Special Tool - Flywheel Puller, M38 × 1.5: 57001-1405**

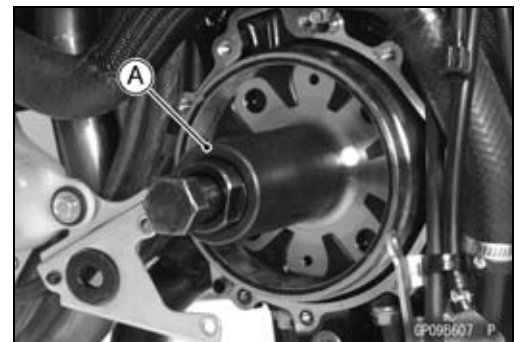
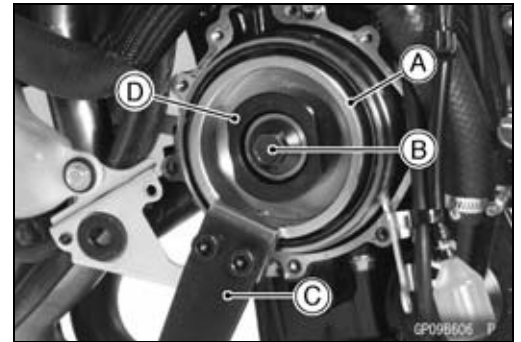

### CAUTION

**Do not attempt to strike the alternator rotor itself. Striking the rotor can cause the magnets to lose their magnetism.**

### Alternator Rotor Installation

- Using a cleaning fluid, clean off any oil or dirt on the following portions and dry them with a clean cloth.
  - Crankshaft Tapered Portion [A]
  - Alternator Rotor Tapered Portion [B]
- Install the washer [C].

### NOTE

○ Confirm the alternator rotor fit or not to the crankshaft before tightening it with specified torque.

- Install the rotor bolt [D] and tighten it with 70 N·m (7.0 kgf·m, 52 ft·lb) of torque.
- Remove the rotor bolt.
- Hold the alternator rotor steady with the rotor holder.

**Special Tools - Grip: 57001-1591**

**Rotor Holder: 57001-1666**

**Stopper [D]: 57001-1679**

**Rotor Holder Attachment: 57001-1689**

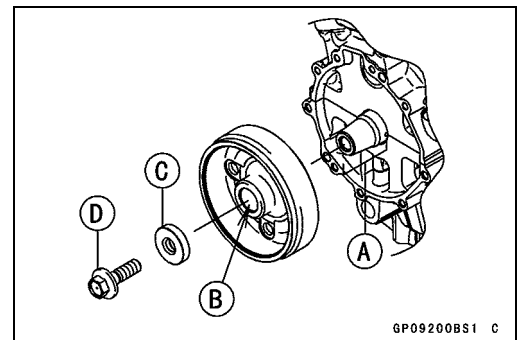

# 16-38 ELECTRICAL SYSTEM

## Charging System

- Check the tightening torque with flywheel puller [A].  
**Special Tool - Flywheel Puller Assembly, M38 x 1.5/M35 x 1.5: 57001-1405**
- ★ If the rotor is not pulled out with 20 N·m (2.0 kgf·m, 15 ft·lb) of drawing torque, it is installed correctly.
- ★ If the rotor is pulled out with under 20 N·m (2.0 kgf·m, 15 ft·lb) of drawing torque, clean off any oil dirt or flaw of the crankshaft and rotor tapered portion, and dry them with a clean cloth. Then, confirm that it is not pulled out with above torque.
- Tighten the alternator rotor bolt [B] while holding the alternator rotor steadily with the holder [A].  
**Special Tools - Grip [C]: 57001-1591**  
**Rotor Holder: 57001-1666**  
**Stopper [D]: 57001-1679**  
**Rotor Holder Attachment: 57001-1689**
- Torque - Alternator Rotor Bolt: 155 N·m (16 kgf·m, 115 ft·lb)**
- Install the alternator cover (see Alternator Cover Installation).

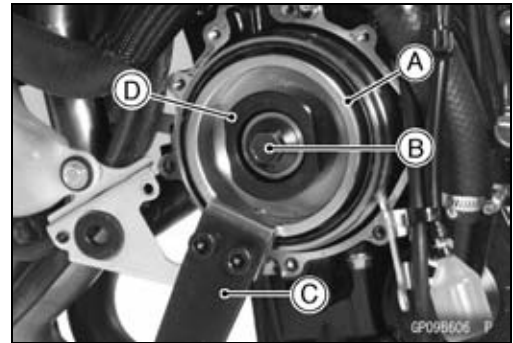
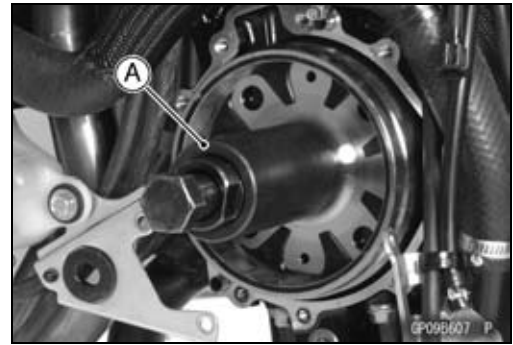

### Alternator Inspection

There are three types of alternator failures: short, open (wire burned out), or loss in rotor magnetism. A short or open in one of the coil wires will result in either a low output, or no output at all. A loss in rotor magnetism, which may be caused by dropping or hitting the alternator, by leaving it near an electromagnetic field, or just by aging, will result in low output.

- To check the alternator output voltage, do the following procedures.
  - Turn off the ignition switch.
  - Set up the fuel tank (see Speed Sensor Removal).
  - Disconnect the alternator lead connector [A].
  - Connect the hand tester as shown in the table 1.
  - Start the engine.
  - Run it at the rpm given in the table 1.
  - Note the voltage readings (total 3 measurements).

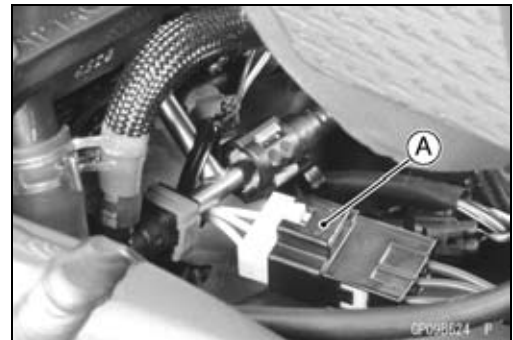

**Table 1 Alternator Output Voltage**

Tester Range	Connections		Reading @4 000 rpm
	Tester (+) to	Tester (-) to	
250 V AC	One White lead	Another White lead	42 V or more

## Charging System

- ★ If the output voltage shows the value in the table, the alternator operates properly.
- ★ If the output voltage shows a much higher than the value in the table, the regulator/rectifier is damaged. A much lower reading than that given in the table indicates that the alternator is defective.
- Check the stator coil resistance as follows.
  - Stop the engine.
  - Connect the hand tester as shown in the table 2.
  - Note the readings (total 3 measurement).

**Table 2 Stator Coil Resistance**

Tester Range	Connections		Reading
	Tester (+) to	Tester (-) to	
$\times 1 \Omega$	One White lead	Another White lead	$0.1 \sim 0.3 \Omega$

- ★ If there is more resistance than shown in the table, or no tester reading (infinity) for any two leads, the stator has an open lead and must be replaced. Much less than this resistance means the stator is shorted, and must be replaced.
- Using the highest resistance range of the hand tester, measure the resistance between each of the white leads and chassis ground.
- ★ Any hand tester reading less than infinity ( $\infty$ ) indicates a short, necessitating stator replacement.
- ★ If the stator coils have normal resistance, but the voltage check showed the alternator to be defective; then the rotor magnets have probably weakened, and the rotor must be replaced.

**Special Tool - Hand Tester: 57001-1394**

### Regulator/Rectifier Removal

- Set up the Fuel Tank (see Speed Sensor Removal).
- Remove:
  - Clamp [A]
  - Connectors [B]
  
- Remove:
  - Bolts [A]
  - Regulator/Rectifier [B]

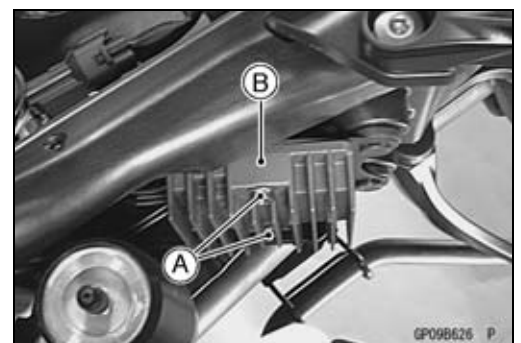
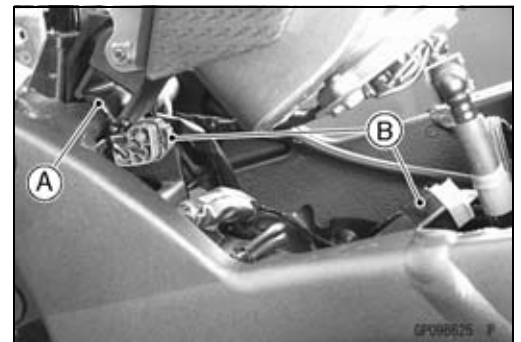

# 16-40 ELECTRICAL SYSTEM

## Charging System

### Regulator/Rectifier Inspection

- Set the hand tester to the  $\times 1 \text{ k}\Omega$  range and make the measurements shown in the table.

**Special Tool - Hand Tester: 57001-1394**

- Connect the hand tester to the regulator rectifier.
- ★ If the tester readings are not as specified, replace the regulator/rectifier.

### CAUTION

**Use only Kawasaki Hand Tester 57001-1394 for this test. A tester other than the Kawasaki Hand Tester may show different readings. If a megger or a meter with a large capacity battery is used, the regulator/rectifier will be damaged.**

### Regulator/Rectifier Resistance (Unit: $\text{k}\Omega$ )

		Tester (+) Lead Connection					
		BK/BL (+)	BK1	BK2	BK3	BK	BK/W (-)
(-)*	BK/BL (+)	—	20 ~ 300	20 ~ 300	20 ~ 300	20 ~ 300	20 ~ 750
	BK1	0 ~ 5	—	20 ~ 300	20 ~ 300	0 ~ 1	20 ~ 750
	BK2	0 ~ 5	20 ~ 300	—	20 ~ 300	20 ~ 300	20 ~ 750
	BK3	0 ~ 5	20 ~ 300	20 ~ 300	—	20 ~ 300	20 ~ 750
	BK	0 ~ 5	0 ~ 1	20 ~ 300	20 ~ 300	—	20 ~ 750
	BK/W (-)	5 ~ 20	5 ~ 20	5 ~ 20	5 ~ 20	5 ~ 20	—

(-)\*: Tester (-) Lead Connection

- Install the regulator/rectifier.

**Torque - Regulator/Rectifier Bolts: 6.9 N·m (0.70 kgf·m, 61 in·lb)**

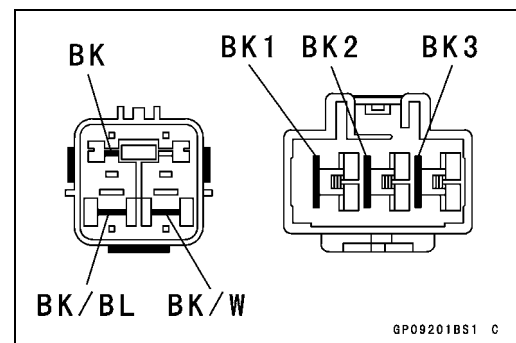



## Charging System

### Charging Voltage Inspection

- Check the battery condition (see Charging Condition Inspection).
- Warm up the engine to obtain actual alternator operating conditions.
- Remove:
  - Front Seat (see Front Seat Removal in the Frame chapter)
  - Caps [A]
- Check that the ignition switch is turned off, and connect the hand tester [B] as shown in the table.

#### Special Tool - Hand Tester: 57001-1394

- Start the engine, and note the voltage readings at various engine speeds with the headlight turned on and then turned off. (Disconnect the headlight connector in the upper fairing.) The readings should show nearly battery voltage when the engine speed is low, and, as the engine speed rises, the readings should also rise. But they must be kept under the specified voltage.

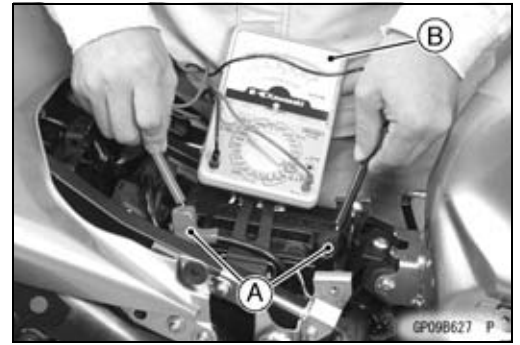

### Charging Voltage

Tester Range	Connections		Reading
	Tester (+) to	Tester (-) to	
25 V DC	Battery (+)	Battery (-)	14.2 ~ 15.0 V

- Turn off the ignition switch to stop the engine, and disconnect the hand tester.
- ★ If the charging voltage is kept between the values given in the table, the charging system is considered to be working normally.
- ★ If the charging voltage is much higher than the values specified in the table, the regulator/rectifier is defective or the regulator/rectifier leads are loose or open.
- ★ If the charging voltage does not rise as the engine speed increases, then the regulator/rectifier is defective or the alternator output is insufficient for the loads. Check the alternator and regulator/rectifier to determine which part is defective.



Ignition System

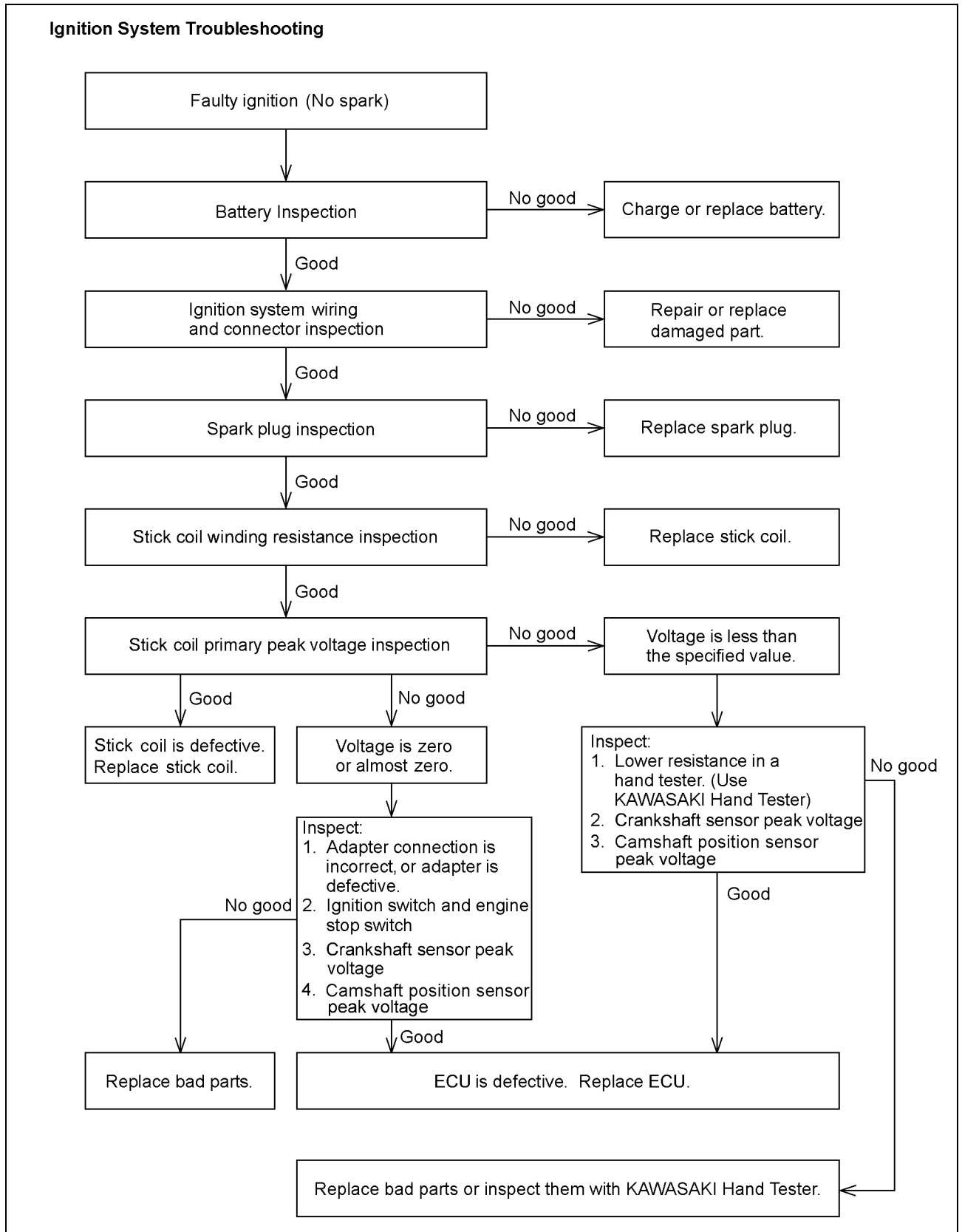

## 16-44 ELECTRICAL SYSTEM

### Ignition System

#### **⚠ WARNING**

The ignition system produces extremely high voltage. Do not touch the spark plugs or stick coils while the engine is running, or you could receive a severe electrical shock.

#### **CAUTION**

Do not disconnect the battery leads or any other electrical connections when the ignition switch is on, or while the engine is running. This is to prevent IC igniter damage.

Do not install the battery backwards. The negative side is grounded. This is to prevent damage to the diodes and IC igniter.

#### ***Crankshaft Sensor Removal***

- Set up the Fuel Tank (see Speed Sensor Removal).  
Crankshaft Sensor Lead Connector [A]

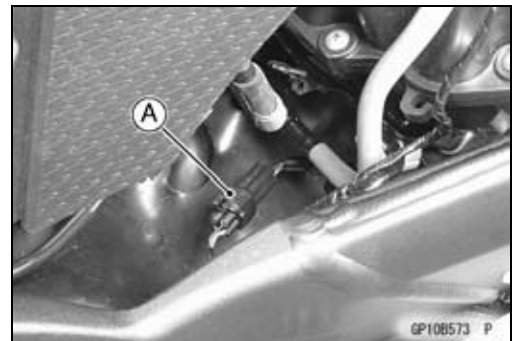

- Remove:
  - Right Middle Fairing (see Middle Fairing Removal in the Frame chapter)
  - Starter Idle Gear (see Starter Idle Gear Removal)
  - Rubber Cap [A]
  - Oil Pressure Switch Terminal [B]
  - Bolts [C]
  - Crankshaft Sensor [D]
  - Clamp [E]
- Pull out the grommet [F].

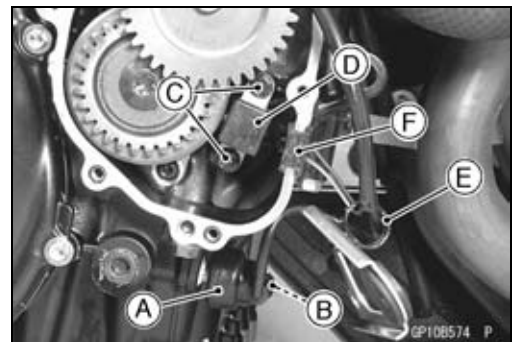

#### ***Crankshaft Sensor Installation***

- Route the crankshaft sensor lead correctly (see Cable, Wire, and Hose Routing section in the Appendix chapter).
- Tighten:
  - Torque - Crankshaft Sensor Bolts: 5.9 N·m (0.60 kgf·m, 52 in·lb)**
- Apply silicone sealant.
  - Crankshaft Sensor Lead Grommet (Around) [A]
  - Crankcase Halves Mating Surfaces [B]
  - Sealant - Kawasaki Bond (Silicone Sealant): 92104-0004**
- Install:
  - Clamp
  - Starter Clutch Cover (see Starter Idle Gear Installation in the Crankshaft/Transmission chapter)

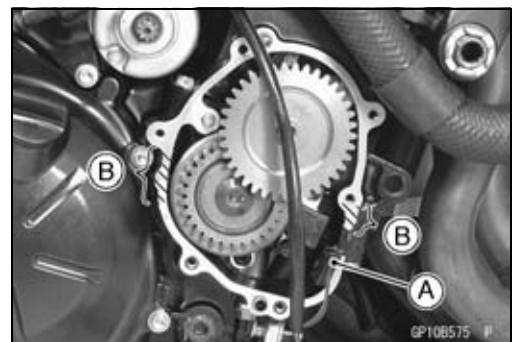

## Ignition System

- Connect:
  - Sensor Lead Connector
  - Oil Pressure Switch Lead (see Oil Pressure Switch Installation in the Engine Lubrication System)
- Install the removed parts (see appropriate chapters).

### **Crankshaft Sensor Inspection**

- Remove:
  - Crankshaft Sensor Lead Connector (see Crankshaft Sensor Removal)
- Set the hand tester [A] to the  $\times 100 \Omega$  range and connect the (+) lead to the black lead and (-) lead to the black/yellow lead in the connector [B].

**Special Tool - Hand Tester: 57001-1394**

- ★ If there is more resistance than the specified value, the coil has an open lead and must be replaced. Much less than this resistance means the coil is shorted, and must be replaced.

**Crankshaft Sensor Resistance: 380 ~ 570  $\Omega$**

- Using the highest resistance range of the tester, measure the resistance between the crankshaft sensor leads and chassis ground.
- ★ Any tester reading less than infinity ( $\infty$ ) indicates a short, necessitating replacement of the crankshaft sensor assembly.

### **Crankshaft Sensor Peak Voltage**

#### **NOTE**

- Be sure the battery is fully charged.
- Using the peak voltage adapter is a more reliable way to determine the condition of the crankshaft sensor than crankshaft sensor internal resistance measurements.

- Remove:
  - Crankshaft Sensor Lead Connector (see Crankshaft Sensor Removal)
- Set the hand tester [A] to the  $\times 10 \text{ V DC}$  range, and connect it peak voltage adapter [B].
- Using the auxiliary leads, connect the black lead (-) [C] of the adapter to black/yellow lead and red lead (+) [D] to black lead in the crankshaft sensor connector [E].
- Turn the ignition switch on and engine stop switch on.

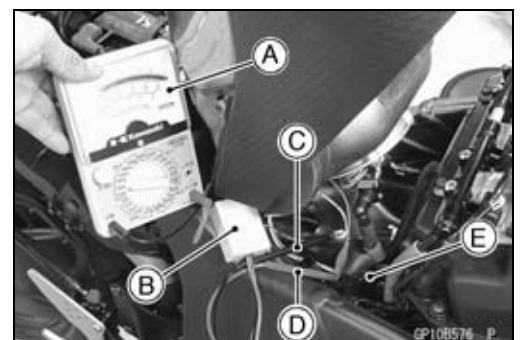
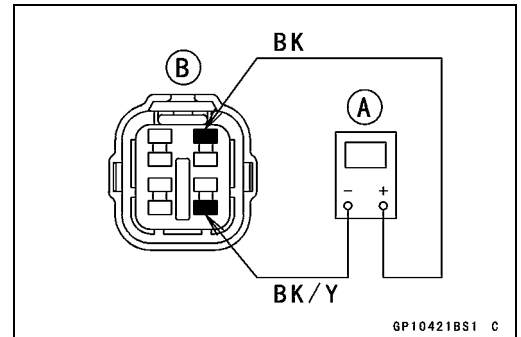

## 16-46 ELECTRICAL SYSTEM

### Ignition System

- Pushing the starter button, turn the engine 4 ~ 5 seconds with the transmission gear in neutral to measure the crankshaft sensor peak voltage.
- Repeat the measurement 5 or more times.

#### Crankshaft Sensor Peak Voltage

Standard: 3.2 V or more

Special Tools - Hand Tester: 57001-1394

Peak Voltage Adapter: 57001-1415

Type: KEK-54-9-B

- ★ If the tester reading is not specified one, check the crankshaft sensor.

#### Stick Coil Removal

- Remove:
  - Air Cleaner Housing (see Air Cleaner Housing Removal in the Fuel System (DFI) chapter)
- Disconnect the stick coil connectors [A].
- Pull the stick coils [B] off the spark plugs.

#### CAUTION

Do not pry the connector part of the coil while removing the coil.

#### Stick Coil Installation

- Apply grease to the stick coils [A].
- Insert the stick coils [B] as shown being careful of the coil head directions.
- Align the lines [C] of the cylinder head cover and coil head connectors.

- Be sure the stick coils are installed by pulling up [A] it lightly.

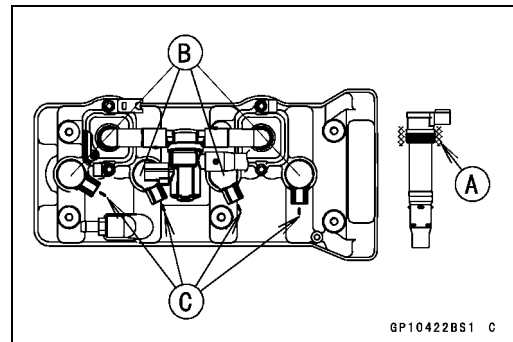
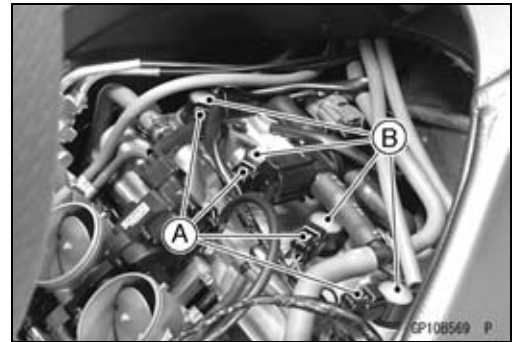

#### CAUTION

Do not tap the coil head while installing the coil.

- Connect the connectors.
- Run the hoses and harness correctly (see Cable, Wire, and Hose Routing section in the Appendix chapter).
- Install removed parts (see appropriate chapters).

## Ignition System

### Stick Coil Inspection

- Remove the stick coils (see Stick Coil Removal).
- Measure the primary winding resistance [A] as follows.
  - Connect the hand tester between the coil terminals.
  - Set the tester to the  $\times 1 \Omega$  range, and read the tester.
- Measure the secondary winding resistance [B] as follows.
  - Connect the tester between the plug terminal and (-) coil terminal.
  - Set the tester to the  $\times 1 \text{ k}\Omega$  range and read the tester.

#### Ignition Coil Winding Resistance

**Primary Windings:** 1.2 ~ 1.6  $\Omega$

**Secondary Windings:** 8.5 ~ 11.5  $\text{k}\Omega$

- ★ If the tester does not read as specified, replace the coil.

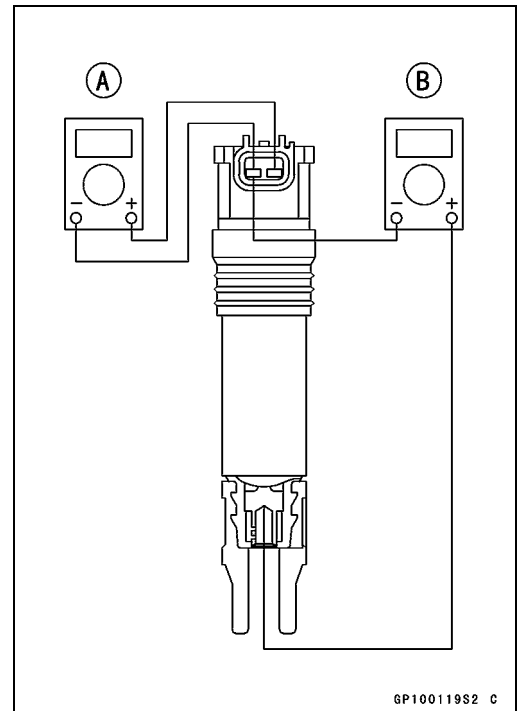

### Stick Coil Primary Peak Voltage

#### NOTE

- Be sure the battery is fully charged.

- Remove the stick coils (see Stick Coil Removal), but do not remove the spark plugs.
- Measure the primary peak voltage as follows.
  - Install the new spark plugs [A] into each stick coils [B], and ground them onto the engine.
  - Connect peak voltage adapter [C] into the hand tester [D] which is set to the  $\times 250 \text{ V DC}$  range.
  - Connect the adapter to the lead wire-peak voltage adapter [E] which is connected between the stick coil connector and stick coil.

ECU [F]

**Special Tools - Hand Tester: 57001-1394**

**Peak Voltage Adapter: 57001-1415**

**Type: KEK-54-9-B**

**Lead Wire-Peak Voltage Adapter: 57001-1449**

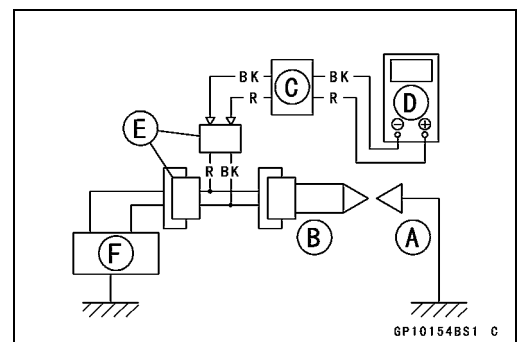
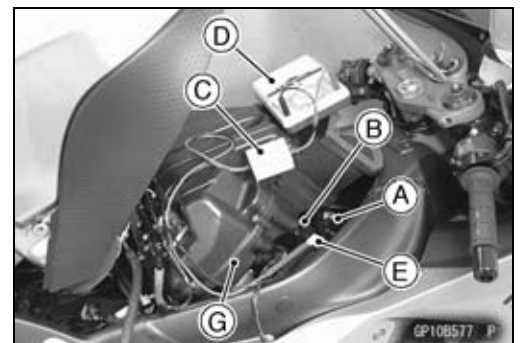

#### Primary Lead Connection

**Adapter (R, +) to lead wire-peak voltage adapter:**

**Stick Coil #1 (BK)**

**Stick Coil #2 (BK/G)**

**Stick Coil #3 (BK/W)**

**Stick Coil #4 (BK/O)**

**Adapter (BK, -) to lead wire-peak voltage adapter (R)**

- Temporary install the air cleaner housing [G] (see Air Cleaner Housing Installation in the Fuel System (DFI) chapter).
- Remove the fuel hose fitting of the fuel pump side.
- Connect the prepared fuel hose to the fuel supply pipe of the fuel pump.
- Insert the fuel hose into the proper container.

## 16-48 ELECTRICAL SYSTEM

### Ignition System

#### **⚠ WARNING**

**To avoid extremely high voltage shocks, do not touch the spark plugs or tester connections.**

- Turn the ignition switch and the engine stop switch ON.
- Pushing the starter button, turn the engine 4 ~ 5 seconds with the transmission in neutral to measure the primary peak voltage.
- Repeat the measurements 5 times for one stick coil.

#### **Stick Coil Primary Peak Voltage**

**Standard: 80 V or more**

- Repeat the test for the other stick coil.
- ★ If the reading is less than the specified value, check the following.
  - Stick Coils (see Stick Coil Inspection)
  - Crankshaft Sensor (see Crankshaft Sensor Inspection)
  - ECU (see ECU Power Supply Inspection in the Fuel System (DFI) chapter)

#### **Spark Plug Removal**

- Refer to the Spark Plug Replacement in the Periodic Maintenance chapter (see Spark Plug Replacement in the Periodic Maintenance chapter).

#### **Spark Plug Installation**

- Refer to the Spark Plug Replacement in the Periodic Maintenance chapter (see Spark Plug Replacement in the Periodic Maintenance chapter).

#### **Spark Plug Clean and Inspection**

- Remove the spark plug, and visually inspect.
- Clean the spark plug, preferably in a sandblasting device, and then clean off any abrasive particles. The plug may also be cleaned using a high flash-point solvent and a wire brush or other suitable tool.
- ★ If the spark plug center electrode [A] and/or side electrode [B] are corroded or damaged, or if the insulator [C] is cracked, replace the plug.
- ★ If the spark plug is dirtied or the carbon is accumulated, replace the spark plug.
- Measure the gap [D] with a wire-type thickness gauge.
- ★ If the gap is incorrect, replace the spark plug.

**Spark Plug Gap: 0.7 ~ 0.8 mm (0.028 ~ 0.031 in.)**

- Use the standard spark plug or its equivalent.

**Spark Plug: CR9E**

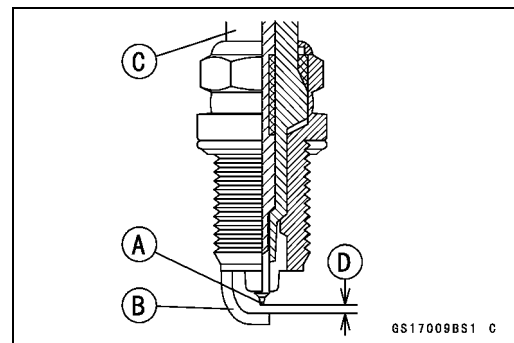



## Ignition System

### Camshaft Position Sensor Removal

- Remove:
  - Air Cleaner Housing (see Air Cleaner Housing Removal in the Fuel System (DFI) chapter)
  - Camshaft Position Sensor Connector [A]



- Remove:
  - Middle Fairings (see Middle Firing Removal in the Frame chapter)
  - Radiator Mounting Bolts (see Radiator Removal in the Cooling System chapter)
  - Heat Installation Plate [A]
  - Camshaft Position Sensor Bolt [A]
  - Camshaft Position Sensor [B]

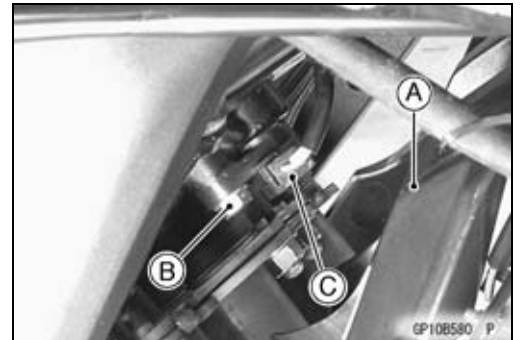

### Camshaft Position Sensor Installation

- Apply high-temperature grease to the O-ring [A].
- Tighten:
  - Torque - Camshaft Position Sensor Bolt: 9.8 N·m (1.0 kgf·m, 87 in·lb)**

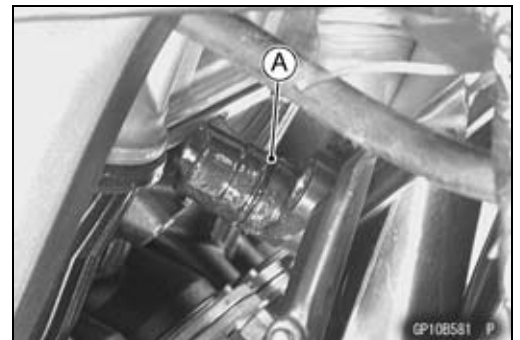

- Install the heat insulation plate [A] so that the left side projections first.
- Fit the projections [B] of the plate into the holes [C] of the frame.
- Install the radiator (see Radiator Installation in the Cooling System chapter).

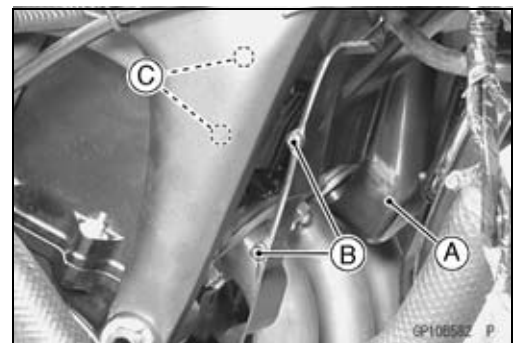

### Camshaft Position Sensor Inspection

- Remove:
  - Camshaft Position Sensor Connector [A]



# 16-50 ELECTRICAL SYSTEM

## Ignition System

- Set the hand tester to the  $\times 10 \Omega$  range and connect it to the terminals.

**Special Tool - Hand Tester: 57001-1394**

- ★ If there is more resistance than the specified value, the sensor coil has an open lead and must be replaced. Much less than this resistance means the sensor coil is shorted, and must be replaced.

**Camshaft Position Sensor Resistance: 400 ~ 460  $\Omega$**

- Using the highest resistance range of the tester, measure the resistance between the camshaft position sensor leads and chassis ground.
- ★ Any tester reading less than infinity ( $\infty$ ) indicates a short, necessitating replacement of the camshaft position sensor.

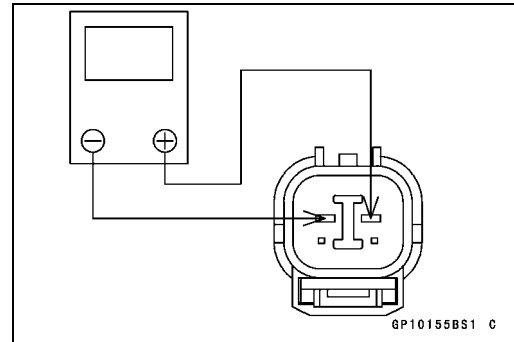

### Camshaft Position Sensor Peak Voltage Inspection

- Remove:  
Camshaft Position Sensor Connector (see Camshaft Position Sensor Removal)
- Set the hand tester [A] to the 10 V DC range.
- Connect the peak voltage adapter [B] to the hand tester and camshaft position sensor leads in the terminals.

**Special Tools - Hand Taster: 57001-1394**  
**Peak Voltage Adapter: 57001-1415**  
**Type: KEK-54-9-B**

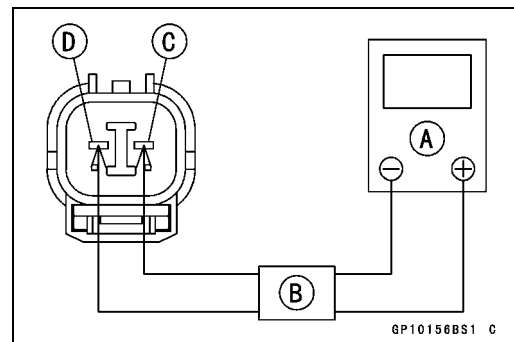

#### Connections:

Camshaft Position Sensor Terminal		Adapter		Hand Tester
White/Yellow [C]	←	Red	→	(-)
Yellow [D]	←	Black	→	(+)

- Turn the ignition switch and engine stop switch on.
- Pushing the starter button, turn the engine 4 ~ 5 seconds with the transmission gear in neutral to measure the camshaft position sensor peak voltage.
- Repeat the measurement 5 or more times.

**Camshaft Position Sensor Peak Voltage**  
**Standard: 0.4 V or more**

- ★ If the peak voltage is lower than the standard, inspect the camshaft position sensor.

## Ignition System

### Interlock Operation Inspection

- Using the stand [A], raise the rear wheel off the ground.



### 1st Check

- Start the engine to the following conditions.

#### Condition

**Transmission Gear** → 1st Position

**Clutch Lever** → Release

**Side Stand** → Down or Up

- Turn the ignition switch ON and push the starter button.
- Then the starter motor should not turn when the starter system circuit is normality.
- ★ If the engine is start, inspect the starter lockout switch, gear position switch and relay box.
- ★ If their parts are normality replace the ECU.

### 2nd Check

- Start the engine to the following conditions.

#### Condition

**Transmission Gear** → 1st Position

**Clutch Lever** → Pulled in

**Side Stand** → Up

- Turn the ignition switch ON and push the starter button.
- Then the starter motor should turn when the starter system circuit is normality.
- ★ If the starter motor is not turn, inspect the starter lockout switch, gear position switch and relay box.
- ★ If their parts are normality replace the ECU.

### 3rd Check

- Inspect the engine for its secure stop after the following operations are completed.
- Run the engine to the following conditions.

#### Condition

**Transmission Gear** → 1st Position

**Clutch Lever** → Release

**Side Stand** → Up

- Set the side stand on the ground, then the engine will stop.
- ★ If whichever may not be stopped, inspect the gear position switch, starter lockout switch, side stand switch and relay box.
- ★ If their parts are normality, replace the ECU.

## 16-52 ELECTRICAL SYSTEM

### Ignition System

#### ***IC Igniter Inspection***

○The IC igniter is built in the ECU [A].

- Refer to the Interlock Operation Inspection, Ignition System Troubleshooting chart and Fuel System (DFI) chapter for ECU Power Supply Inspection.

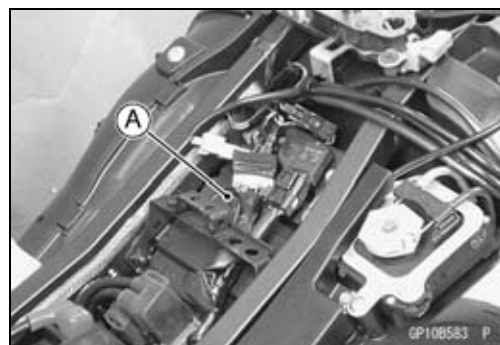

Ignition System

Ignition System Circuit

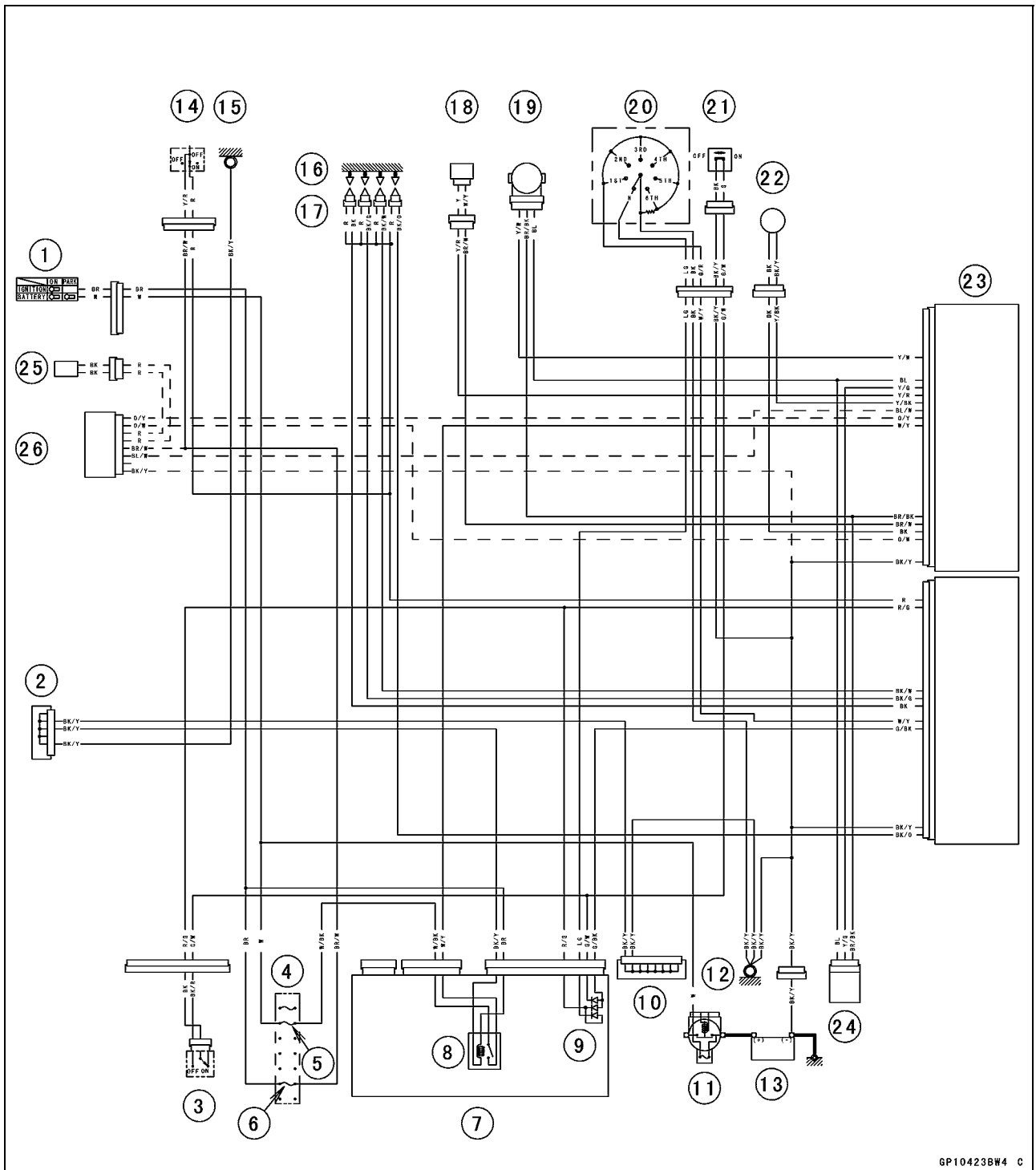

GP10423BW4 C

- |                           |   |
|---------------------------|---|
| 1. Ignition Switch        | 14. Engine Stop Switch                      |
| 2. Joint Connector C      | 15. Cylinder Head Cover Ground              |
| 3. Starter Lockout Switch | 16. Spark plugs                             |
| 4. Fuse Box               | 17. Stick Coils                             |
| 5. ECU Fuse 10 A          | 18. Camshaft Position Sensor                |
| 6. Ignition Fuse 10 A     | 19. Main Throttle Sensor                    |
| 7. Relay Box              | 20. Gear Position Switch                    |
| 8. ECU Main Relay         | 21. Side Stand Switch                       |
| 9. Inter Lock Circuit     | 22. Crankshaft Sensor                       |
| 10. Joint Connector B     | 23. ECU                                     |
| 11. Main Fuse 30 A        | 24. Vehicle-down Sensor                     |
| 12. Frame Ground          | 25. Immobilizer Antenna (Equipped Models)   |
| 13. Battery 12 V 8 Ah     | 26. Immobilizer Amplifier (Equipped Models) |

# 16-54 ELECTRICAL SYSTEM

## Electric Starter System

### Starter Motor Removal

- Remove:
  - Starter Clutch Cover [A] (see Idle Gear Removal in the Crankshaft/Transmission chapter)
- Slide back the rubber cap [B].
- Remove
  - Starter Motor Terminal Bolt [C]
  - Mounting Bolts [D]
- Remove the starter motor [E] from the engine right side.

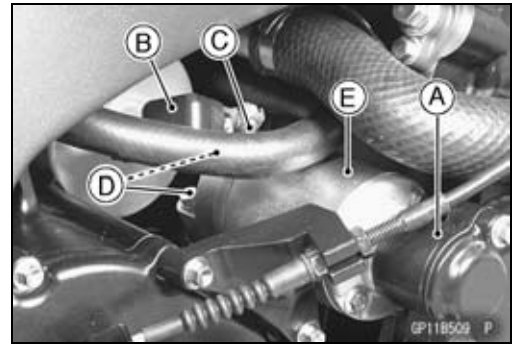

### Starter Motor Installation

#### CAUTION

Do not tap the starter motor shaft or body. Tapping the shaft or body could damage the motor.

- Replace the O-ring [A] with a new one.
- Apply grease to the O-ring.

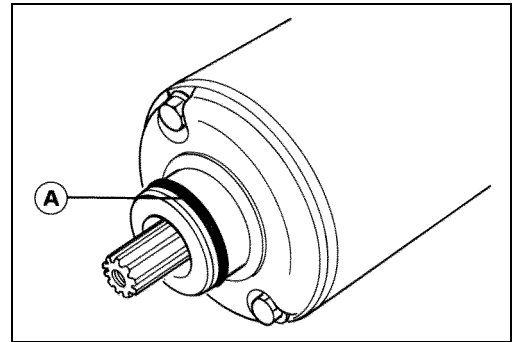

- When installing the starter motor, clean the starter motor legs [A] and crankcase [B] where the starter motor is grounded.

#### NOTE

○ Temporary install the starter motor mounting bolts.

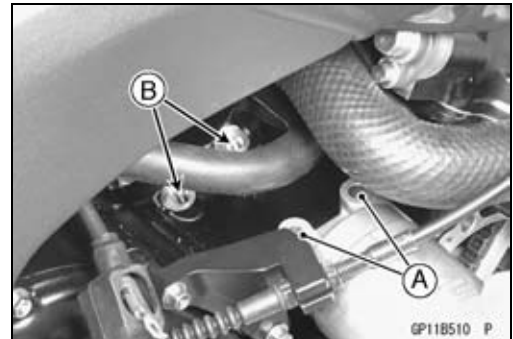

- Install:
    - Starter Clutch Cover (see Starter Clutch Cover Installation in the Crankshaft/Transmission chapter)
  - Fit the cover hole [A] and starter fitting portion [B] then install the cover to the crankcase.
- Tighten:

**Torque - Starter Motor Mounting Bolts: 9.8 N·m (1.0 kgf·m, 87 in·lb)**

**Starter Motor Cable Terminal Bolt: 2.9 N·m (0.30 kgf·m, 26 in·lb)**



## Electric Starter System

### Starter Motor Disassembly

- Take off the starter motor through bolts [A].

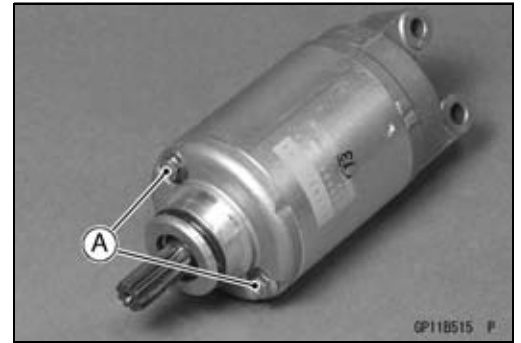

- Remove:
  - Left-hand End Cover [A]
  - Right-hand End Cover [B]
  - Armature [C]
  - Yoke [D]

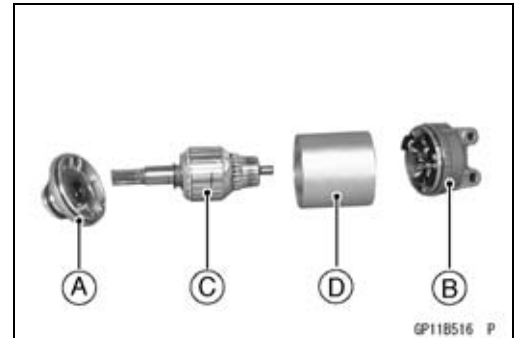

### Starter Motor Assembly

- Apply a thin coat of grease to the oil seal [A].
- Fit the groove [B] of the toothed washer [C] on the projection [D] left-hand end cover.
- Install the washer [E].

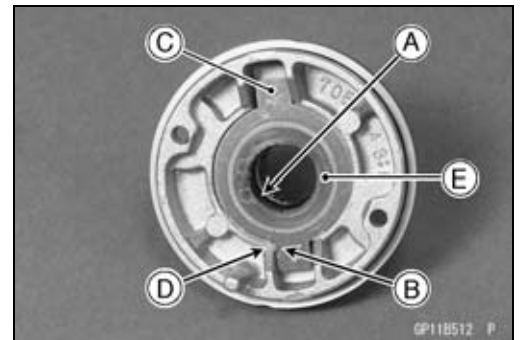

- Press the springs holding the brush leads with suitable clips [A] as shown.
- Put the armature [B] among the brushes.

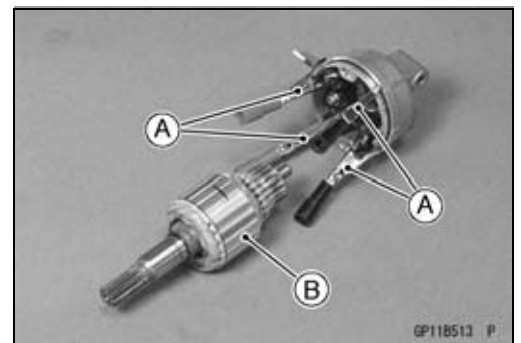

- Install the new O-rings [A] as shown.

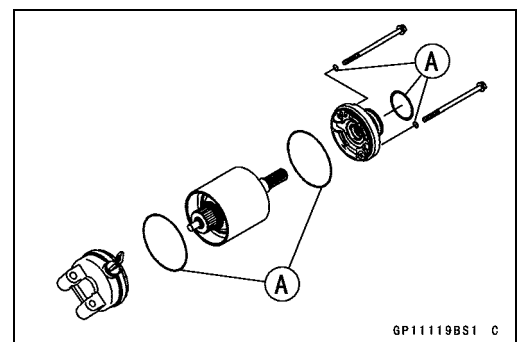

## 16-56 ELECTRICAL SYSTEM

### Electric Starter System

- Align the groove [A] in the right-hand end cover and the hollow mark [B] on the yoke.

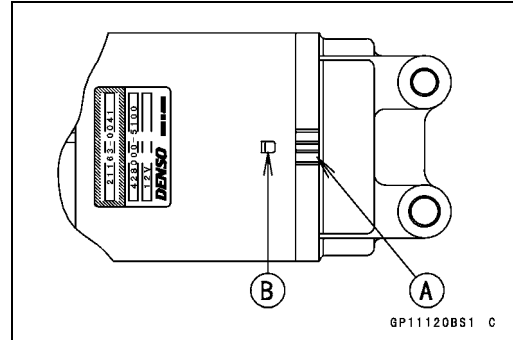

- Align the hollow mark [A] on the left-hand end cover and the hollow mark [B] on the yoke.



#### **Brush Inspection**

- Measure the length [A] of each brush.
- ★ If any is worn down to the service limit, replace the brush holder assembly.

##### **Starter Motor Brush Length**

Standard: 7 mm (0.28 in.)

Service Limit: 3.5 mm (0.14 in.)

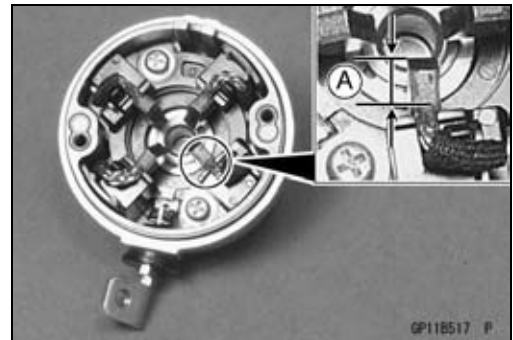

#### **Commutator Cleaning and Inspection**

- Smooth the commutator surface [A] if necessary with fine emery cloth [B], and clean out the grooves.

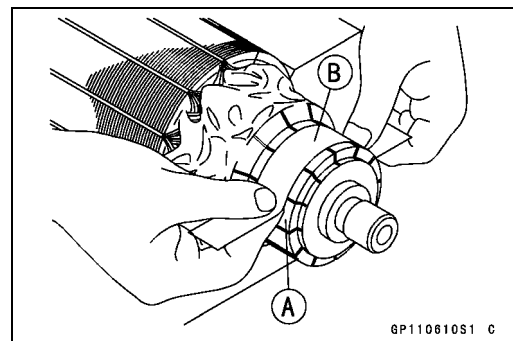

- Measure the diameter [A] of the commutator [B].
- ★ If the commutator diameter is less than the service limit, replace the starter motor with a new one .

##### **Commutator Diameter**

Standard: 24 mm (0.94 in.)

Service Limit: 23 mm (0.91 in.)

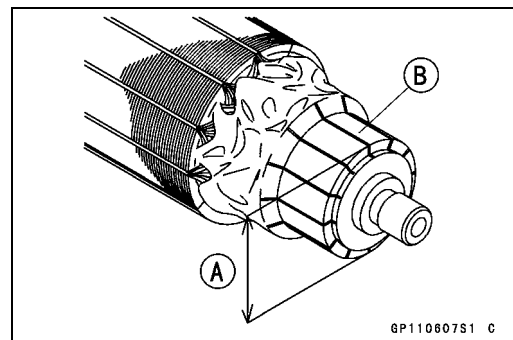



## Electric Starter System

### Armature Inspection

- Using the  $\times 1 \Omega$  hand tester range, measure the resistance between any two commutator segments [A].

**Special Tool - Hand Tester: 57001-1394**

- ★ If there is a high resistance or no reading ( $\infty$ ) between any two segments, a winding is open and the starter motor must be replaced.
- Using the highest hand tester range, measure the resistance between the segments and the shaft [B].
- ★ If there is any reading at all, the armature has a short and the starter motor must be replaced.

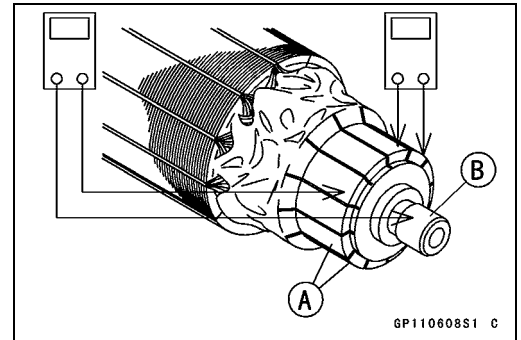

### NOTE

○ Even if the foregoing checks show the armature to be good, it may be defective in some manner not readily detectable with the hand tester. If all other starter motor and starter motor circuit components check good, but the starter motor still does not turn over or only turns over weakly, replace the starter motor with a new one.

### Brush Lead Inspection

- Using the  $\times 1 \Omega$  hand tester range, measure the resistance as shown.

Terminal Bolt and Positive Brush [A]

Right-hand End Cover and Negative Brush [B]

**Special Tool - Hand Tester: 57001-1394**

- ★ If there is not close to zero ohms, the brush lead has an open. Replace the positive brush assembly and/or the negative brush subassembly.

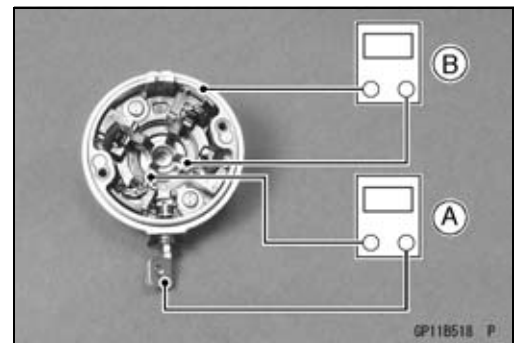

### Right-hand End Cover Assembly Inspection

- Using the highest hand tester range, measure the resistance as shown.

Terminal and Right-hand End Cover [A]

**Special Tool - Hand Tester: 57001-1394**

- ★ If there is any reading, the right-hand end cover assembly have a short. Replace the right-hand end cover assembly.

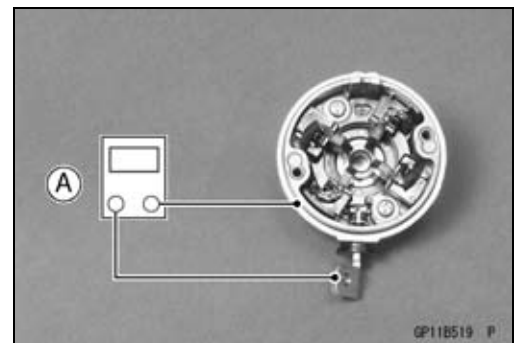

### Starter Relay Inspection

- Disconnect:
  - Battery (-) Terminal
- Remove:
  - Front Seat (see Front Seat Removal in the Frame chapter)
- Pull out the starter relay [A].



# 16-58 ELECTRICAL SYSTEM

## Electric Starter System

- Remove:
  - Connector [A]
  - Battery Cable [B]
  - Starter Cable [C]

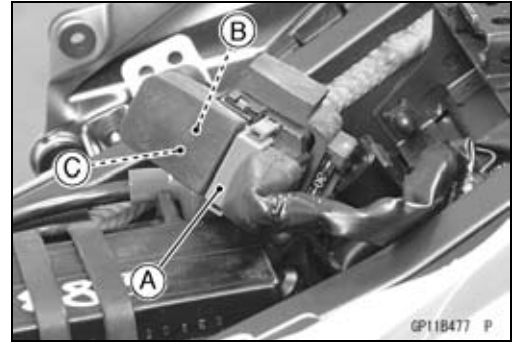

- Connect the hand tester [A] and 12 V battery [B] to the starter relay [C] as shown.

**Special Tool - Hand Tester: 57001-1394**

- ★ If the relay does not work as specified, the relay is defective. Replace the relay.

### Testing Relay

**Tester Range: × 1 Ω range**

- Criteria:**
- When battery is connected → 0 Ω**
  - When battery is disconnected → ∞ Ω**

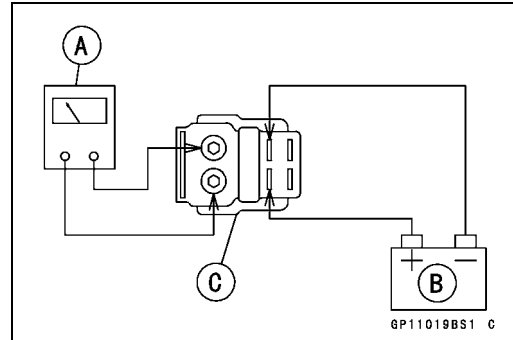

Electric Starter System

Electric Starter Circuit

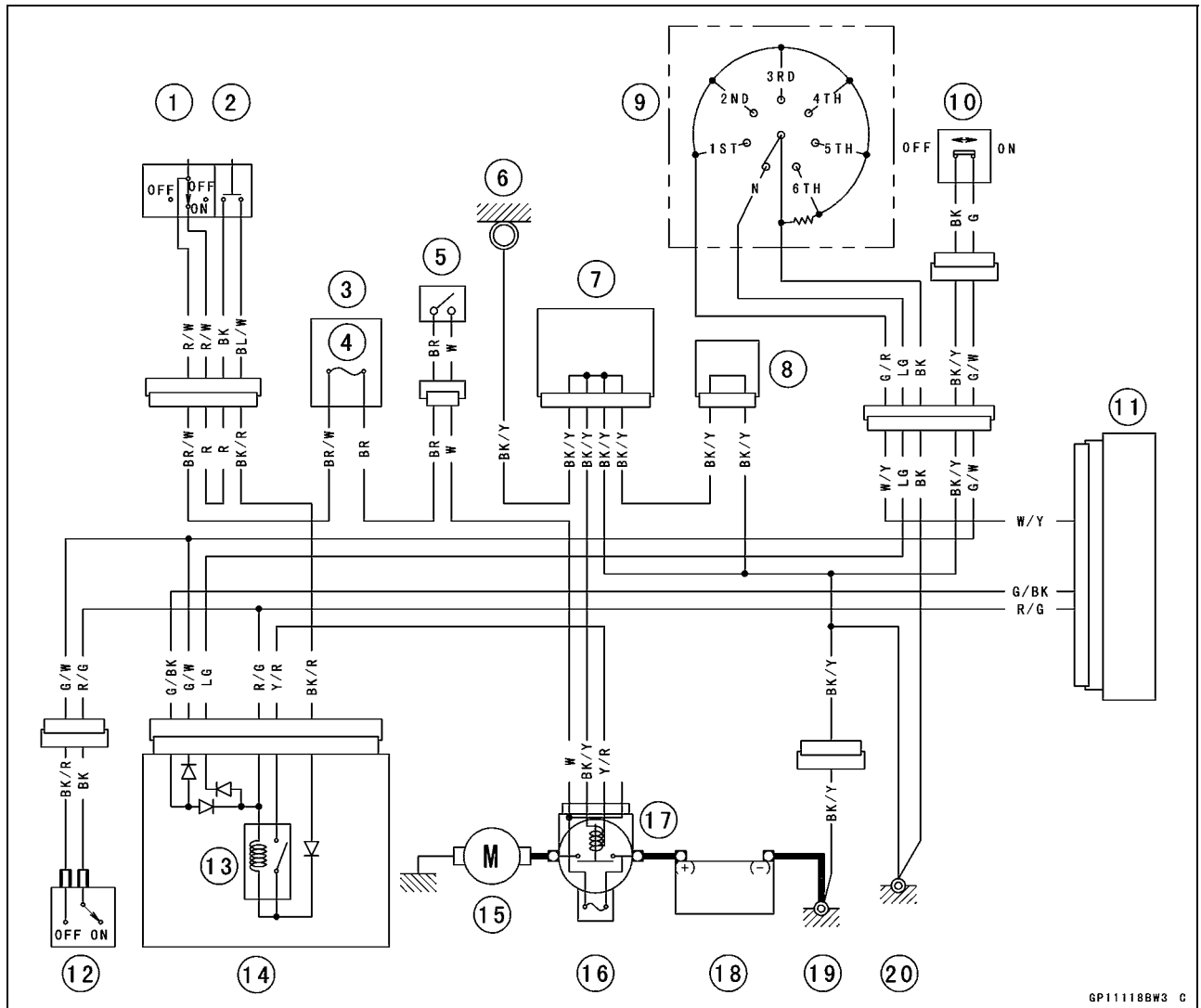

GP11118BW3 C

- |                               |                            |
|-------------------------------|----------------------------|
| 1. Engine Stop Switch         | 11. ECU                    |
| 2. Starter Button             | 12. Starter Lockout Switch |
| 3. Fuse Box                   | 13. Starter Circuit Relay  |
| 4. Ignition Fuse 10 A         | 14. Relay Box              |
| 5. Ignition Switch            | 15. Starter Motor          |
| 6. Cylinder Head Cover Ground | 16. Main Fuse 30 A         |
| 7. Joint Connector C          | 17. Starter Relay          |
| 8. Joint Connector B          | 18. Battery 12 V 8 Ah      |
| 9. Gear Position Switch       | 19. Engine Ground          |
| 10. Side Stand Switch         | 20. Frame Ground           |

## 16-60 ELECTRICAL SYSTEM

### Lighting System

This motorcycle adopt the daylight system and have a headlight relay in the relay box. The headlight does not go on when the ignition switch and the engine stop switch are first turned on. The headlight comes on after the starter button is released and stays on until the ignition switch is turned off. The headlight will go out momentarily whenever the starter button is pressed and come back on when the button is released.

#### **Headlight Beam Horizontal Adjustment**

- Refer to the Headlight Aiming Inspection in the Periodic Maintenance chapter.

#### **Headlight Beam Vertical Adjustment**

- Refer to the Headlight Aiming Inspection in the Periodic Maintenance chapter.

#### **Headlight Bulb Replacement**

- Remove:
  - Right Inner Cover (see Inner Cover Removal in the Frame chapter)
  - Headlight Connector [A]



- Turn the headlight bulb [A] counterclockwise [B].

#### **CAUTION**

**When handling the quartz-halogen bulb, never touch the glass portion with bare hands. Always use a clean cloth. Oil contamination from hands or dirty rags can reduce bulb life or cause the bulb to explode.**

#### **NOTE**

○ Clean off any contamination that inadvertently gets on the bulb with alcohol or soap and water solution.

- Replace the headlight bulb.
- Fit the projections [A] of the bulb in the hollows [B] of the headlight.
- Turn the bulb clockwise.
- After installation, adjust the headlight aim (see Headlight Aiming Inspection in the Periodic Maintenance chapter).

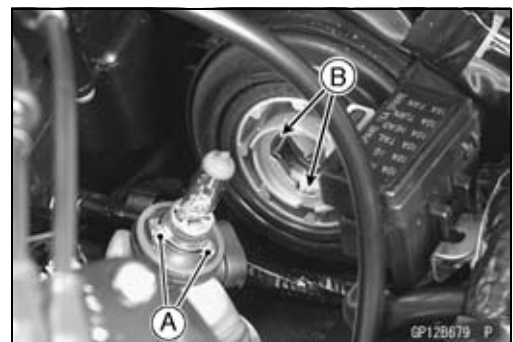
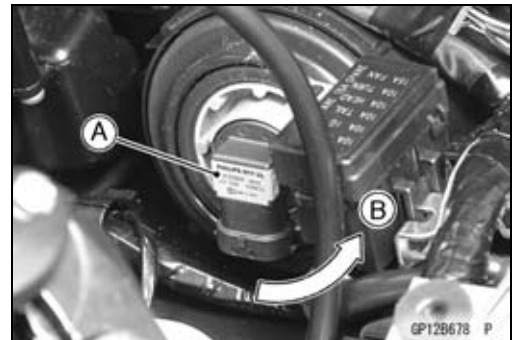

## Lighting System

### City Light Bulb Replacement

- Remove:
  - Center Inner Fairing (see Center Inner Fairing Removal in the Frame chapter)
- Turn the socket [A] counterclockwise and pull out the socket together with the bulb.

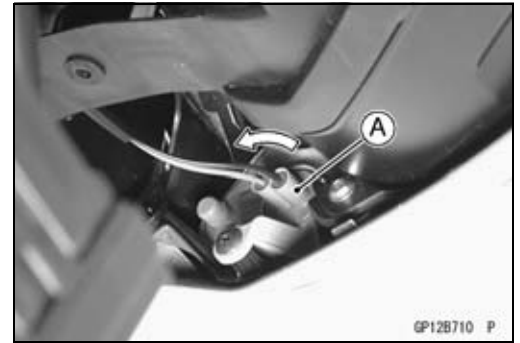

- Pull the bulb [A] out of the socket [B].

<b>CAUTION</b>
<b>Do not turn the bulb. Pull the bulb out to prevent damage to the bulb. Do not use bulb rated for greater wattage than the specified value.</b>

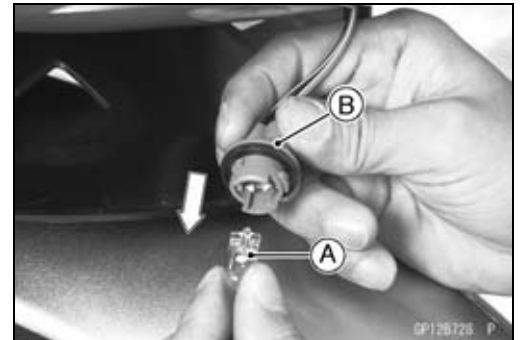

- Pushing the socket and turn it clockwise.
- Fit the projections [A] of the socket into the grooves of the city light housing.

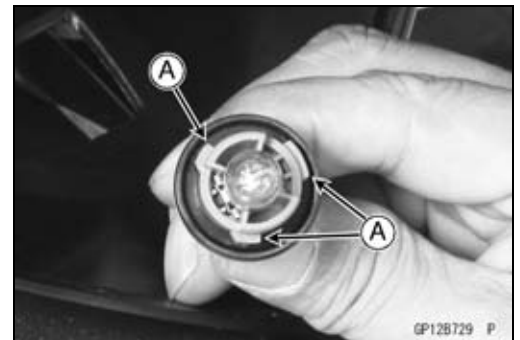

### Headlight Removal/Installation

- Remove:
  - Upper Fairing (see Upper Fairing Removal in the Frame chapter)
  - Center Inner Fairing (see Center Inner Fairing Removal in the Frame chapter)
- Remove:
  - Bolts [A]
  - Screws [B]
- Refer to the Upper Fairing Assembly in the Frame chapter (see Upper Fairing Assembly in the Frame chapter).



### Tail/Brake Light (LED) Removal

- Remove:
  - Seat Cover (see Seat Cover Removal in the Frame chapter)
- Disconnect:
  - Tail/Brake Light (LED) Connector [A]
- Remove:
  - Clamp [B]

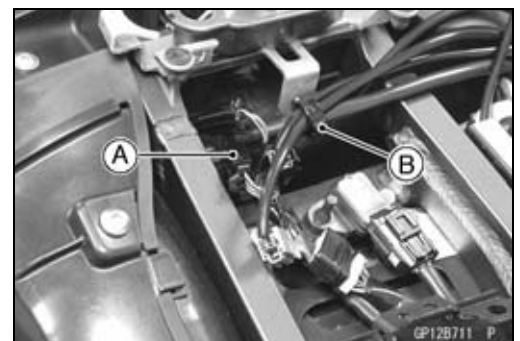

## 16-62 ELECTRICAL SYSTEM

### Lighting System

- Remove:
  - Left Muffler Side Cover [A] (see Turn Signal Removal)
  - Rear Turn Signal Cover [B]
  - Left Turn Signal Light [C] (see Turn Signal Removal)

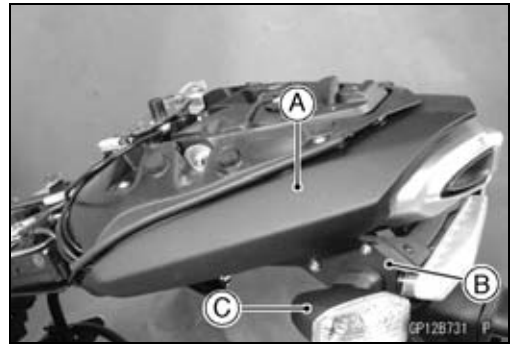

- Unscrew the mounting bolts [A].
- Remove the tail/brake light (LED) [B].

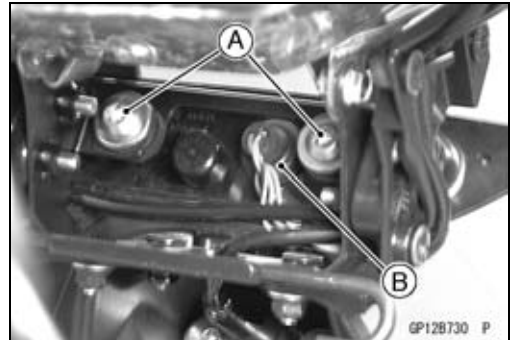

#### **Tail/Brake Light (LED) Installation**

- Fit the groove [A] of the light on the edge [B] of the turn signal cover.

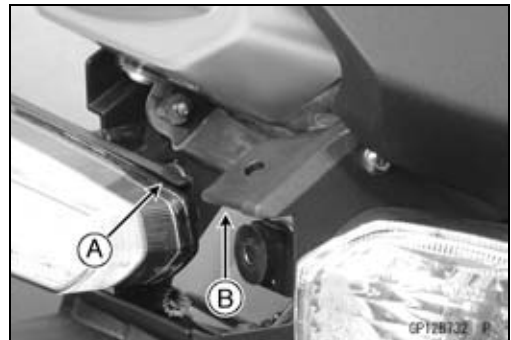

#### **License Plate Light Bulb Replacement**

- Remove:
  - Screws [A]
  - License Plate Light Cover [B]
  - Bulb

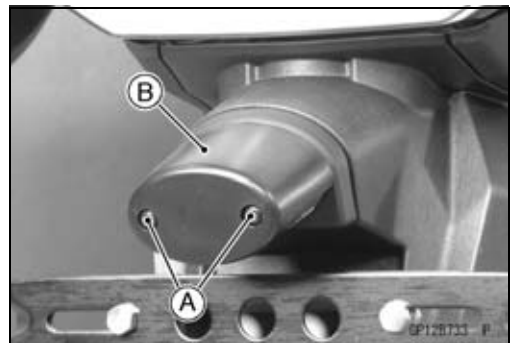

- Insert the new bulb [A] by aligning its upper and lower pins [B] with the upper and lower grooves [C] in the socket, and turn the bulb clockwise.
- Turn the bulb about 15° degrees.

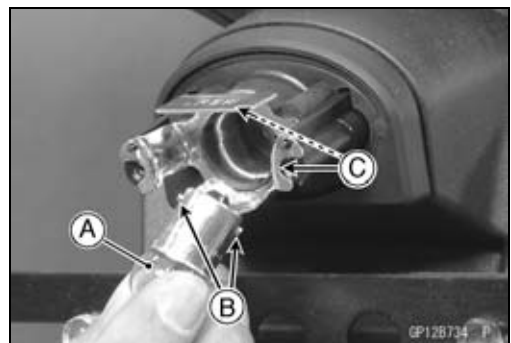

## Lighting System

## Headlight/Tail Light Circuit

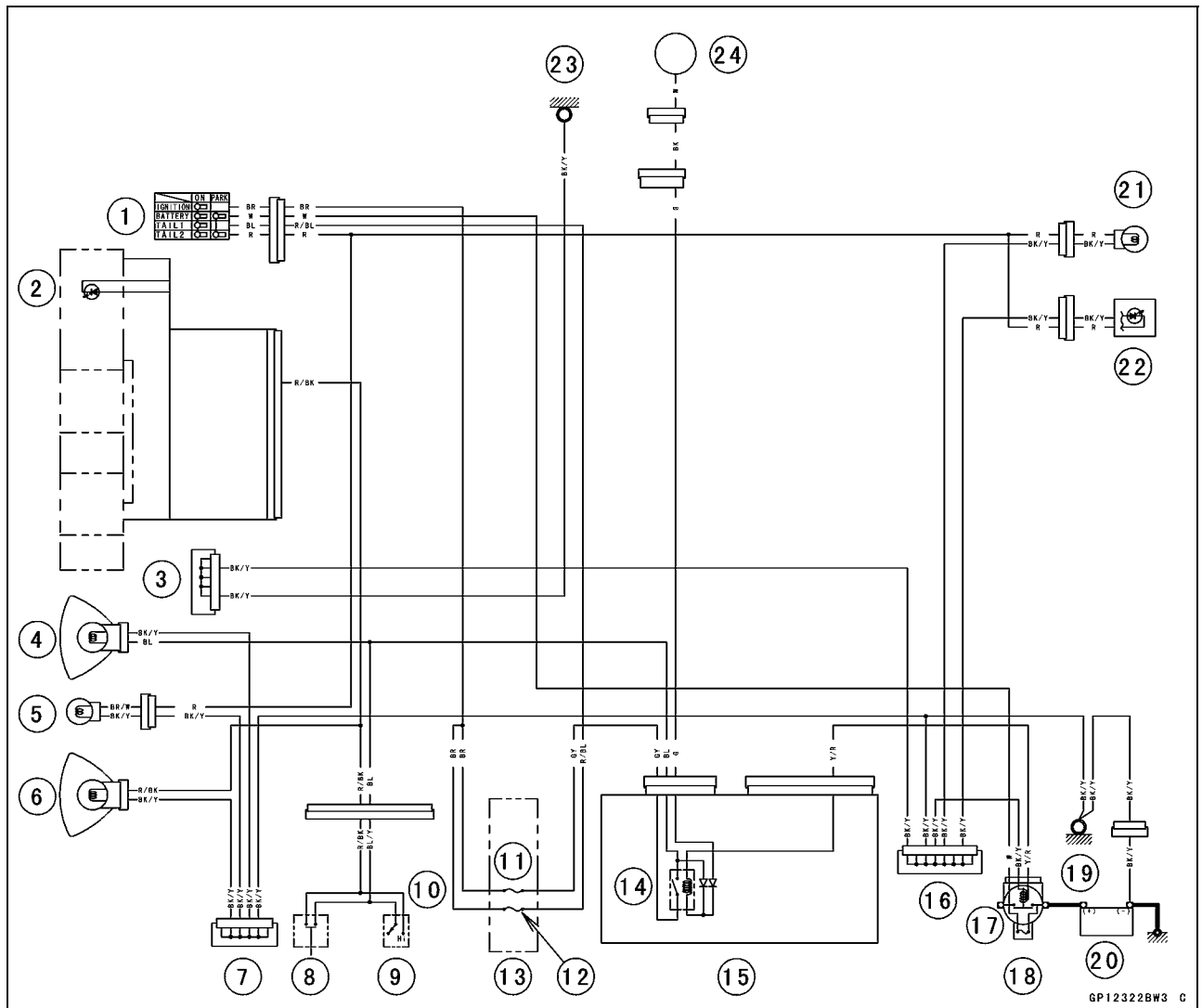

- |                                    |                                |
|------------------------------------|--------------------------------|
| 1. Ignition Switch                 | 13. Fuse Box                   |
| 2. High Beam Indicator Light (LED) | 14. Headlight Relay            |
| 3. Joint Connector C               | 15. Relay Box                  |
| 4. Headlight (Low Beam)            | 16. Joint Connector B          |
| 5. City Light                      | 17. Starter Relay              |
| 6. Headlight (High Beam)           | 18. Main Fuse 30 A             |
| 7. Joint Connector A               | 19. Frame Ground               |
| 8. Passing Button                  | 20. Battery 12 V 8 Ah          |
| 9. Dimmer Switch                   | 21. License Plate Light        |
| 10. Left Handlebar Switch          | 22. Tail/Brake Light (LED)     |
| 11. Headlight Fuse 10 A            | 23. Cylinder Head Cover Ground |
| 12. Tail Light Fuse 10 A           | 24. Alternator                 |

### Turn Signal Light Bulb Replacement For the Front Turn Signal Light

- Remove:
  - Inner Cover (see Inner Cover Removal in the Frame chapter)
  - Canister (California Model, left side)
  - Relay Box (see Relay Box Removal)

## 16-64 ELECTRICAL SYSTEM

### Lighting System

- Turn the socket [A] counterclockwise and pull out the socket together with the bulb.

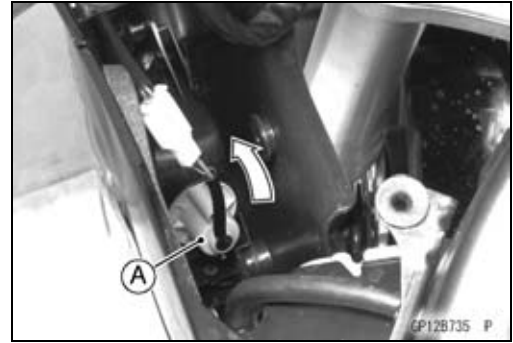

- Push [A] and turn [B] the bulb [C] counterclockwise and remove it.

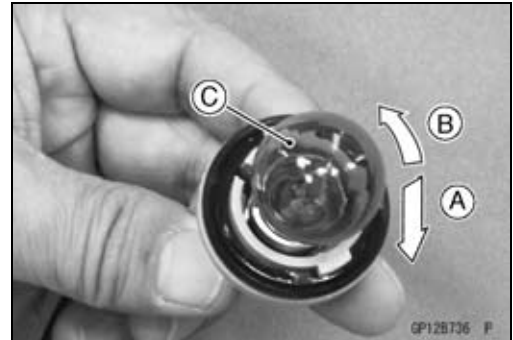

- Insert the new bulb [A] by aligning its upper and lower pins [B] with the upper and lower grooves [C] in the socket, and turn the bulb clockwise.
- Turn the bulb about 15° degrees.
- Pushing the socket and turn it clockwise.
- Fit the projections [D] of the socket into the grooves of the light.

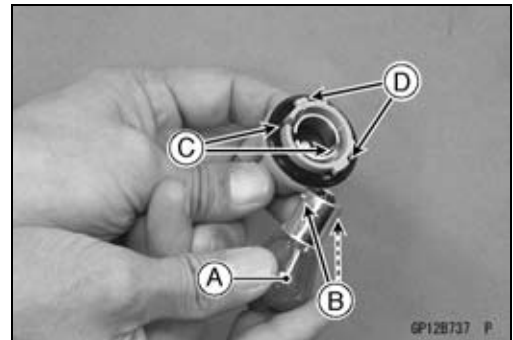

#### For the Rear Turn Signal Light

- Unscrew the screw [A] and remove the turn signal lens [B].



- Push and turn the bulb [A] counterclockwise and remove it.





## Lighting System

- Insert the new bulb [A] by aligning its upper and lower pins [B] with the upper and lower grooves [C] in the socket, and turn the bulb clockwise.

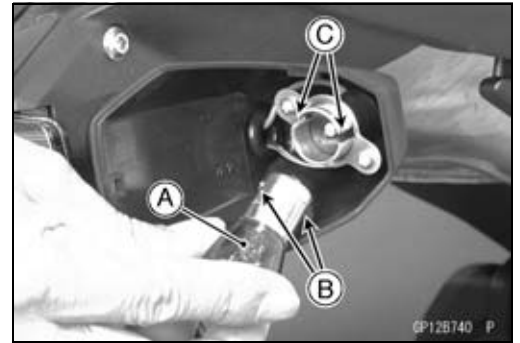

### Turn Signal Light Removal For the Front Turn Signal Light

- Remove:
  - Left Middle Fairings (see Middle Fairing Removal in the Frame chapter)
  - Canister Bracket [A] (California Model)
  - Screws [B]
  - Left Turn Signal Light [C]

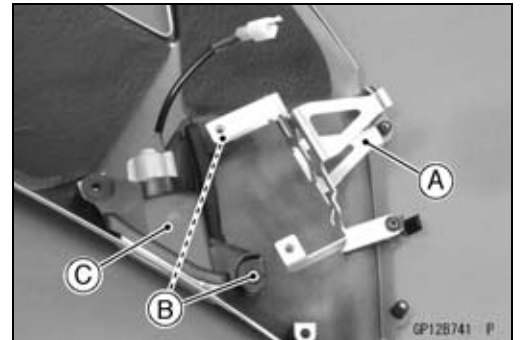

- Remove:
  - Right Middle Fairing (see Middle Fairing Removal in the Frame chapter)
  - Screws [A]
  - Relay Box Bracket with Relay Box [B]
  - Right Turn Signal Light

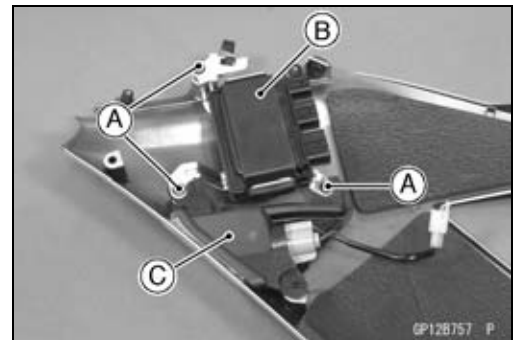

### For the Rear Turn Signal Light

- Remove:
  - Seat Cover (see Seat Cover Removal in the Frame chapter)
  - Right and Left Turn Signal Light Connectors [A]



- Remove:
  - Screws [A]
  - Left Muffler Side Cover [B]
- Pull the cover forward to clear the hook portion [C].

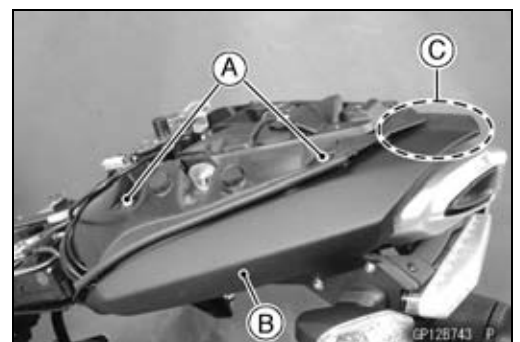

## 16-66 ELECTRICAL SYSTEM

### Lighting System

- Remove:
  - Quick Rivet [A]
  - Screws [B]
  - Left Turn Signal Light with Cover [C]

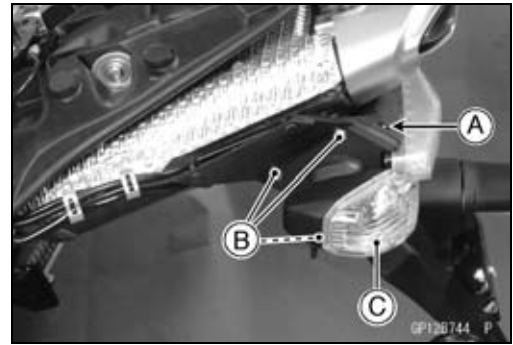

- Remove:
  - Tail/Brake Light (see Tail/Brake Light Removal)
  - Screws [A]
  - Right Turn Signal Light with Cover [B]

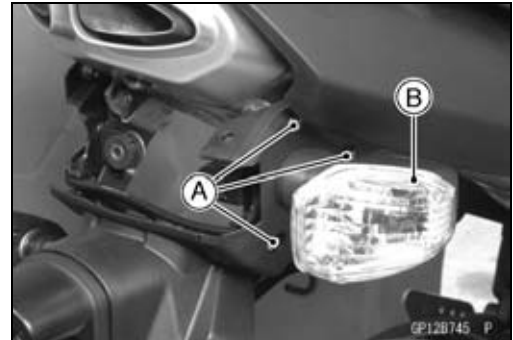

- Remove:
  - Screws [A]
- Separate the light [C] and cover [B].

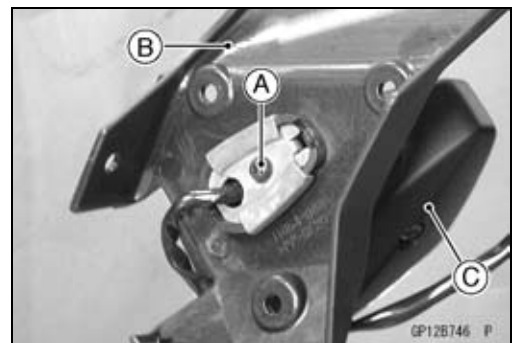

### ***Turn Signal Relay Inspection***

- Remove:
  - Right Inner Cover (see Inner Cover Removal in the Frame chapter)
  - Turn Signal Relay [A]

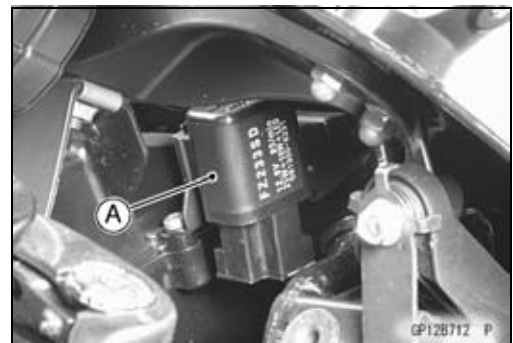

**Lighting System**

**United States, Canada and Australia Models**

- Connect one 12 V battery and turn signal lights as indicated in the figure, and count how many times the lights flash for one minute.

Turn Signal Relay [A]

Turn Signal Lights [B]

12 V Battery [C]

- ★ If the lights do not flash as specified, replace the turn signal relay.

**Testing Turn Signal Relay**

Load		Flashing Times (c/m*)
The Number of Turn Signal Lights	Wattage (W)	
1**	21	140 ~ 250
2	42	75 ~ 95

\*: Cycle(s) per minute

\*\* : Correspond to "one light burned out"

**Other than United States, Canada and Australia Models**

- Connect one 12 V battery and turn signal lights as indicated in the figure, and count how many times the lights flash for one minute.

Turn Signal Relay [A]

Turn Signal Lights [B]

12 V Battery [C]

- ★ If the lights do not flash as specified, replace the turn signal relay.

**Testing Turn Signal Relay**

Load		Flashing Times (c/m*)
The Number of Turn Signal Lights	Wattage (W)	
1**	21	Light stays on
2	42	75 ~ 95

\*: Cycle(s) per minute

\*\* : Correspond to "one light burned out"

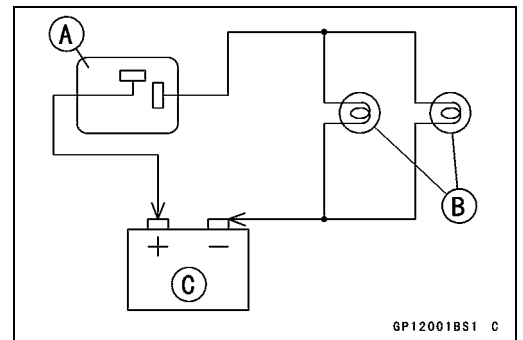
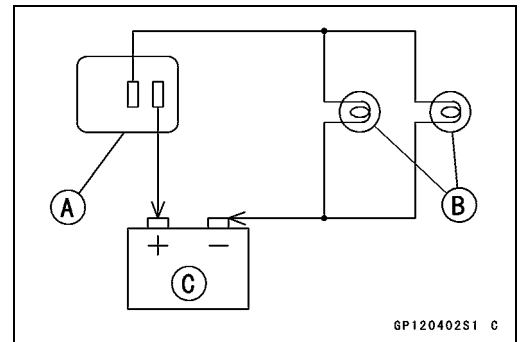

# 16-68 ELECTRICAL SYSTEM

## Lighting System

### Turn Signal Light Circuit

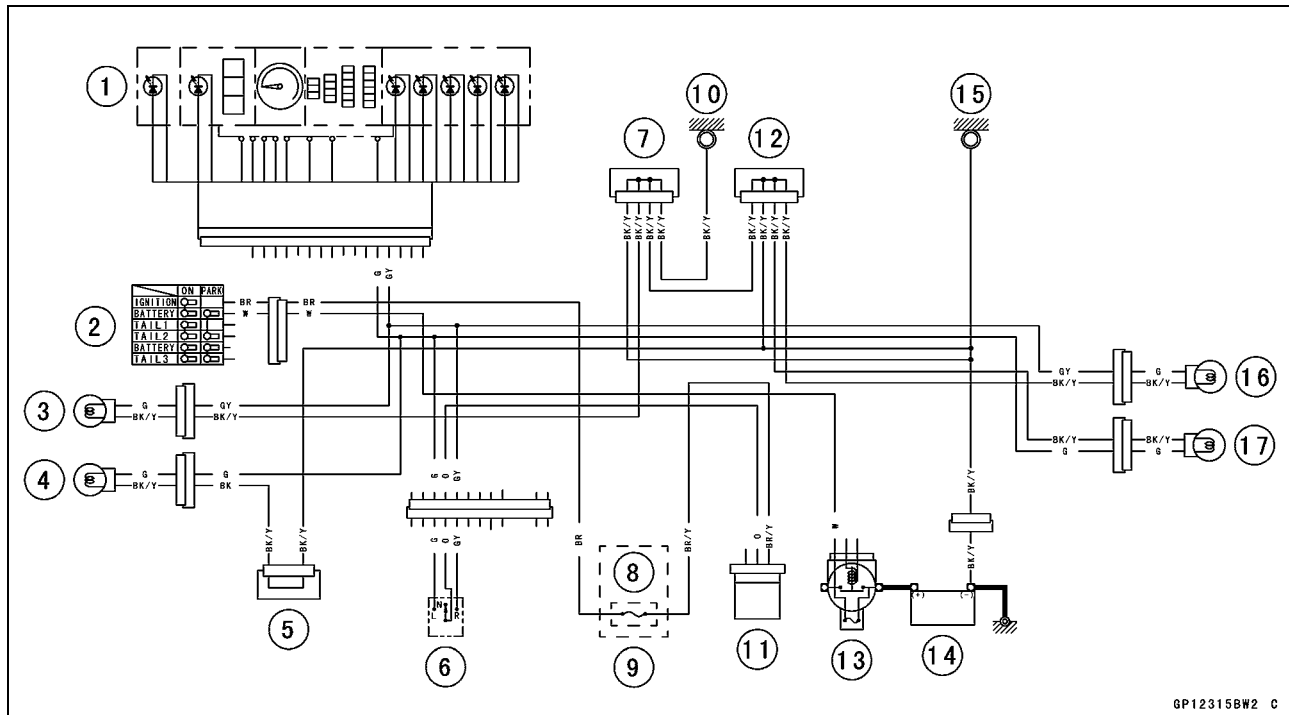

GP12315BW2 C

- |                                  |                                  |
|----------------------------------|----------------------------------|
| 1. Meter Unit                    | 9. Fuse Box                      |
| 2. Ignition Switch               | 10. Cylinder Head Cover Ground   |
| 3. Front Right Turn Signal Light | 11. Turn Signal Relay            |
| 4. Front Left Turn Signal Light  | 12. Joint Connector B            |
| 5. Joint Connector A             | 13. Main Fuse 30 A               |
| 6. Turn Signal Switch            | 14. Battery 12 V 8 Ah            |
| 7. Joint Connector C             | 15. Frame Ground                 |
| 8. Turn Signal Relay Fuse 10 A   | 16. Rear Left Turn Signal Light  |
|                                  | 17. Rear Right Turn Signal Light |

## Air Switching Valve

### Air Switching Valve Operation Test

- Refer to the Air Suction System Damage Inspection in the Periodic Maintenance chapter.

### Air Switching Valve Unit Test

- Remove the air switching valve (see Air Switching Valve Removal in the Engine Top End chapter).
- Set the hand tester [A] to the  $\times \Omega$  range and connect it to the air switching valve terminals as shown.

**Special Tool - Hand Tester: 57001-1394**

#### Air Switching Valve Resistance

**Standard: 18 ~ 22  $\Omega$  at 20°C (68°F)**

- ★ If the tester does not read as specified value, replace it with a new one.

- Connect the 12 V battery [A] to the air switching valve terminals as shown.

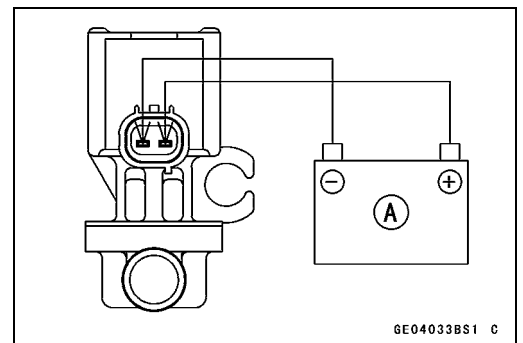
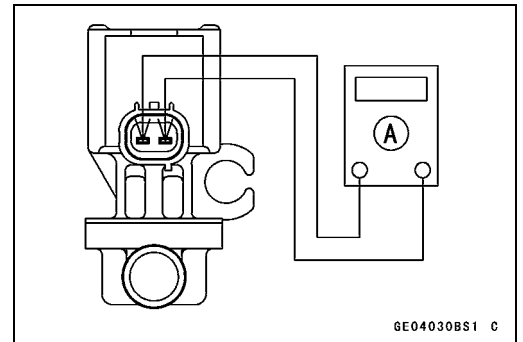

- Blow the air to the inlet air duct [A], and make sure does not flow the blown air from the outlet air ducts [B].

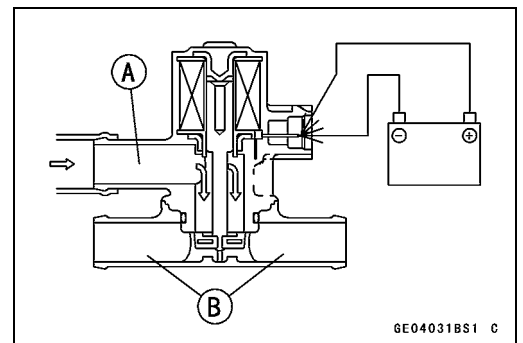

- Disconnect the 12 V battery.
- Blow the air to the inlet air duct [A] again, and make sure flow the blown air from the outlet air ducts [B].
- ★ If the air switching valve does not operate as described, replace it with a new one.

#### NOTE

- To check air flow through the air switching valve, just blow through the air switching valve hose (inlet side) [C].

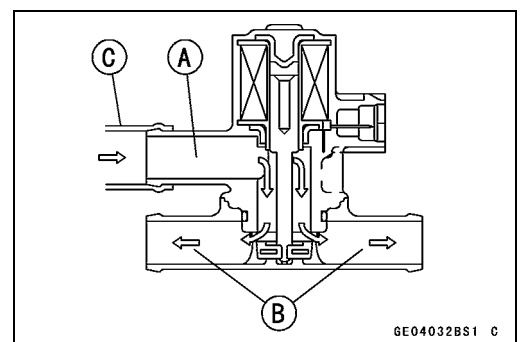

# 16-70 ELECTRICAL SYSTEM

## Radiator Fan System

### Fan Motor Inspection

- Remove:
  - Right Inner Cover (see Inner Cover Removal in the Frame chapter)
- Disconnect the connector [A].
- Using an auxiliary wires, supply battery power to the fan motor.
- ★ If the fan does not rotate, the fan motor is defective and must be replaced.
- ★ If the fan rotate, inspect the fan system circuit.



### Radiator Fan Circuit ZX600P7F

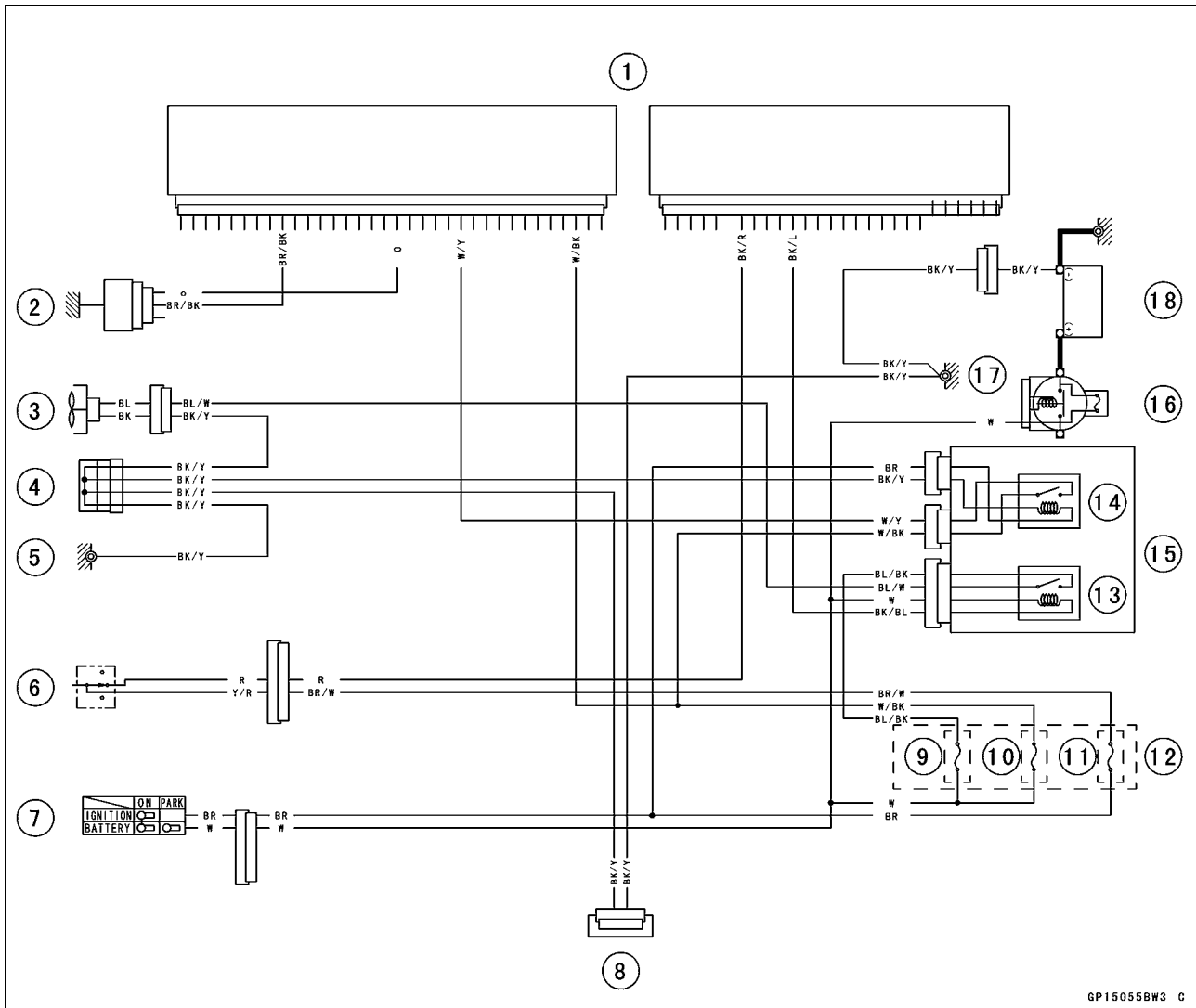

GP15055BW3 C

- |                               |                        |
|-------------------------------|------------------------|
| 1. ECU                        | 10. ECU Fuse 10 A      |
| 2. Water Temperature Sensor   | 11. Ignition Fuse 10 A |
| 3. Radiator Fan               | 12. Fuse Box           |
| 4. Joint Connector C          | 13. Radiator Fan Relay |
| 5. Cylinder Head Cover Ground | 14. ECU Main Relay     |
| 6. Engine Stop Switch         | 15. Relay Box          |
| 7. Ignition Switch            | 16. Main Fuse 30 A     |
| 8. Joint Connector B          | 17. Frame Ground       |
| 9. Fan Fuse 15 A              | 18. Battery 12 V 8 Ah  |

Radiator Fan System

Radiator Fan Circuit  
ZX600P8F

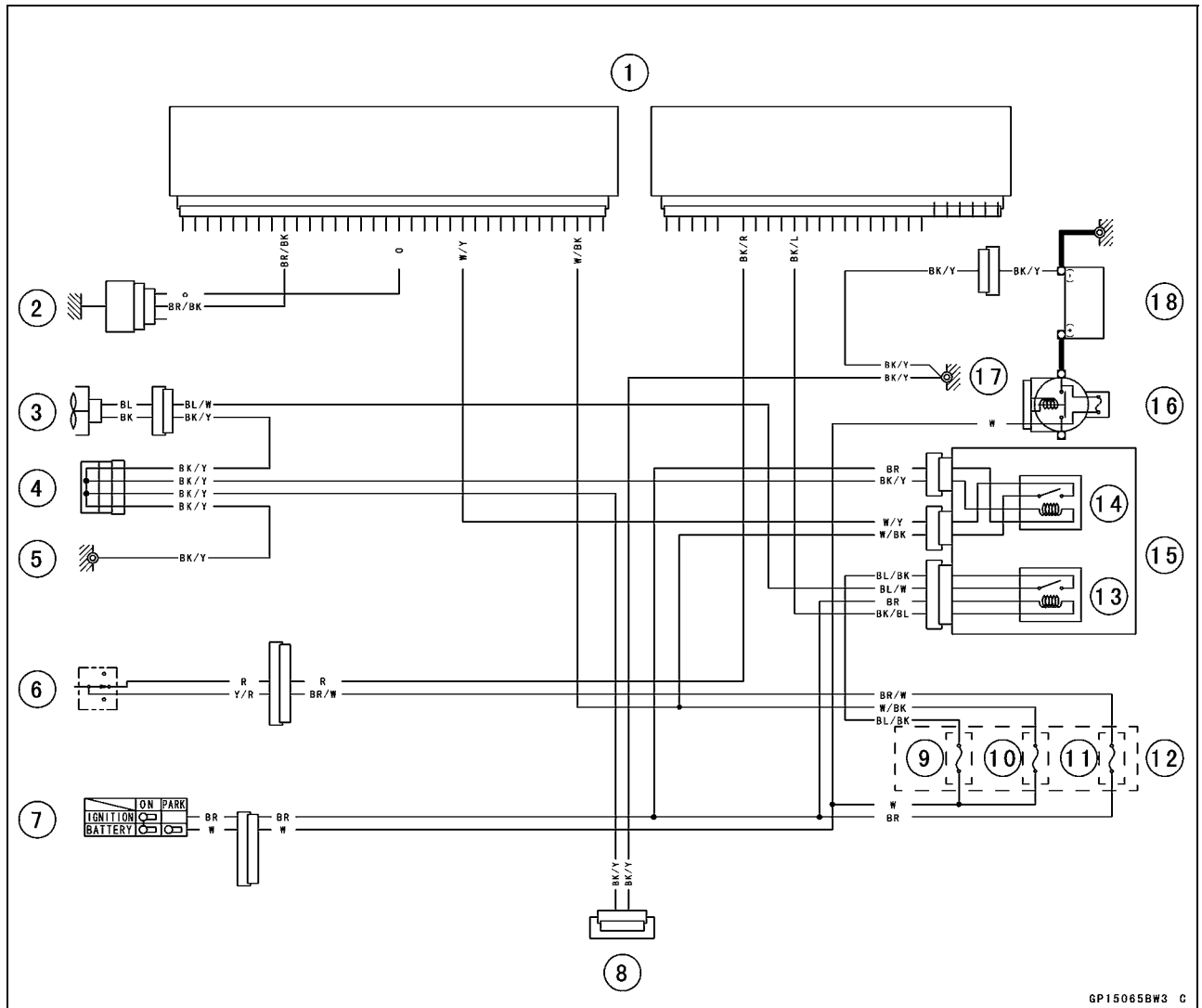

GP15065BW3 C

- |                               |                        |
|-------------------------------|------------------------|
| 1. ECU                        | 10. ECU Fuse 10 A      |
| 2. Water Temperature Sensor   | 11. Ignition Fuse 10 A |
| 3. Radiator Fan               | 12. Fuse Box           |
| 4. Joint Connector C          | 13. Radiator Fan Relay |
| 5. Cylinder Head Cover Ground | 14. ECU Main Relay     |
| 6. Engine Stop Switch         | 15. Relay Box          |
| 7. Ignition Switch            | 16. Main Fuse 30 A     |
| 8. Joint Connector B          | 17. Frame Ground       |
| 9. Fan Fuse 15 A              | 18. Battery 12 V 8 Ah  |

## 16-72 ELECTRICAL SYSTEM

### Meter, Gauge, Indicator Unit

#### Meter Unit Removal

- Remove:
  - Windshield (see Windshield Removal in the Frame chapter)
- Pull out the rubber cover [A].
- Disconnect the connector [B].
- Bolts [C]

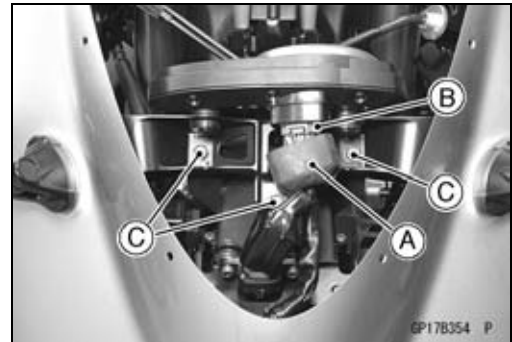

- Remove:
  - Nut [A]
  - Bolts [B]
  - Fairing Bracket with Meter [C]

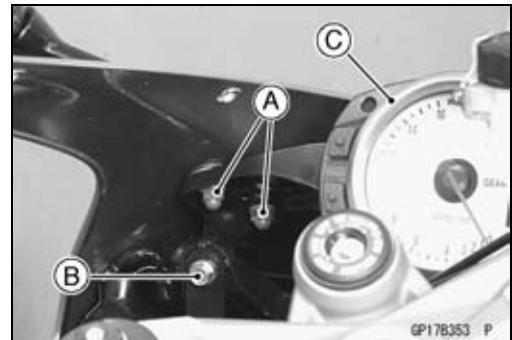

- Remove the screws [A].

#### CAUTION

Place the meter unit so that the face is up. If a meter unit is left upside down or sideways for any length of time, it will malfunction.



#### Meter Unit Disassembly

- Remove:
  - Meter Unit (see Meter Unit Removal)
  - Screws [A]

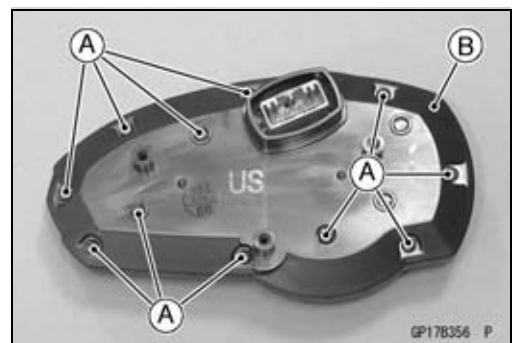

- Separate the lower meter cover [A], meter assembly [B] and upper meter cover [C].

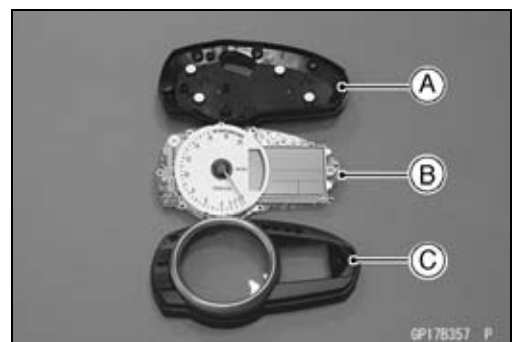



## Meter, Gauge, Indicator Unit

### Electronic Unit (Combination Meter) Inspection

- Remove the meter unit [A].
  - [1] Neutral Indicator Light (LED) Ground (-)
  - [2] Right Turn Signal Indicator Light (LED) (+)
  - [3] High Beam Indicator Light (LED) (+)
  - [4] Water Temperature Sensor
  - [5] Lap Time (+)
  - [6] Stop Watch (+)
  - [7] Unused
  - [8] Unused
  - [9] Unused
  - [10] Left Turn Signal Indicator Light (LED) (+)
  - [11] Warning Indicator Light (LED) Ground (-)
  - [12] Tachometer Pulse
  - [13] Speed Sensor Pulse
  - [14] ECU Communication Pulse
  - [15] Fuel Reserve Switch
  - [16] Ignition
  - [17] Battery (+)
  - [18] Speed Sensor Supply Voltage
  - [19] Ground (-)
  - [20] Unused

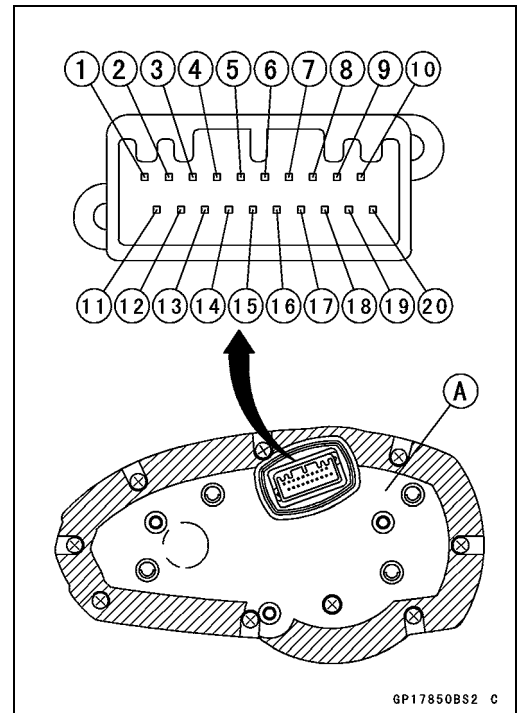

### CAUTION

**Do not drop the meter unit. Place the meter unit so that it faces upward. If the meter unit is left upside down or sideways for a long time or dropped, it will malfunction.**

**Do not short each terminals.**

### Check 1: Meter Unit Primary Operation

- Using the auxiliary leads, connect the 12 V battery [A] to the meter unit connector as follows.
  - Connect the battery positive terminal to the terminal [17].
  - Connect the battery negative terminal to the terminal [19].

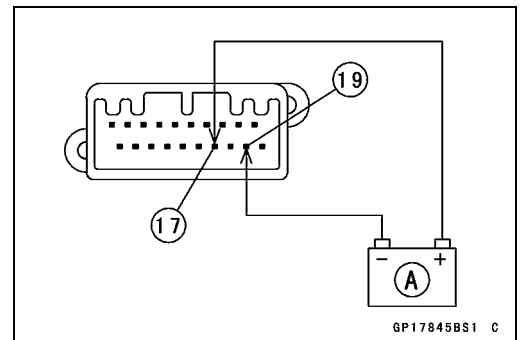

- Check that the tachometer needle [A] momentarily points their last readings and back to the minimum position.
- ★ If the meter unit does not work, replace the meter assembly.

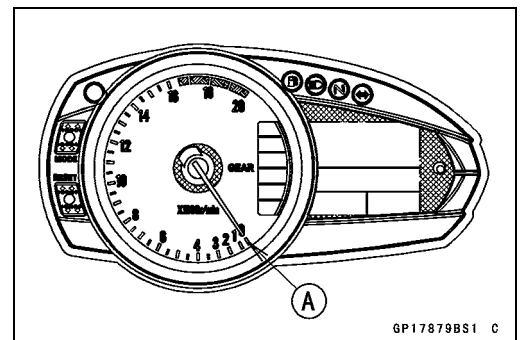

## 16-74 ELECTRICAL SYSTEM

### Meter, Gauge, Indicator Unit

- Connect the terminal [16] and the terminal [17].

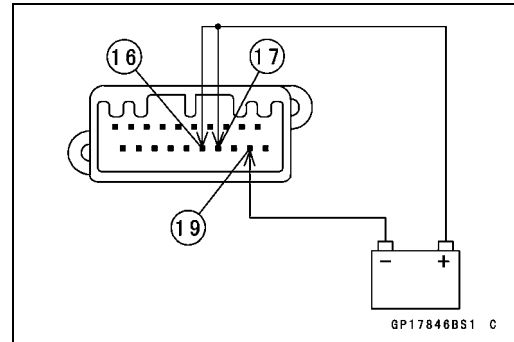

- When the terminals are connected, check that following items.

- The tachometer needle [A] momentarily points it last readings and back to the minimum position.
- All LCD segments [B] appear for 1.5 seconds and all LCD segments appear for 1 second.
- The oil pressure warning indicator light (LED) blinks [C].

#### LCD segment actions for 1.5 seconds.

	Gear Position Indicator	Speedometer/ODO meter/Clock and Water Temperature Gauge
Action 1	Segments appear from up to down	Segments appear from left to right
Action 2	Segments disappear from up to down	Segments disappear from left to right
Action 3	Segments appear from up to down	Segments appear from left to right

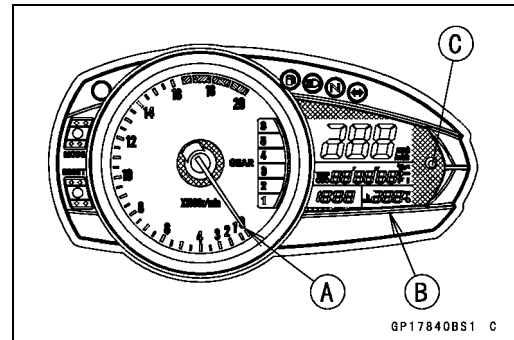

- ★ If the LCD segments and LED warning light will not appear, replace the meter assembly.
- Disconnect the terminal [16].
- All the LCD segments and warning light (LED) disappear.
- ★ If the segments do not disappear, replace the meter assembly.

## Meter, Gauge, Indicator Unit

### Check 2: Meter Communication Line (Service Code 39) Check

- Connect the leads in the same circuit as Check 1.
- Wait 10 seconds and the FI [A] in the display and warning light (LED) [B] flash.

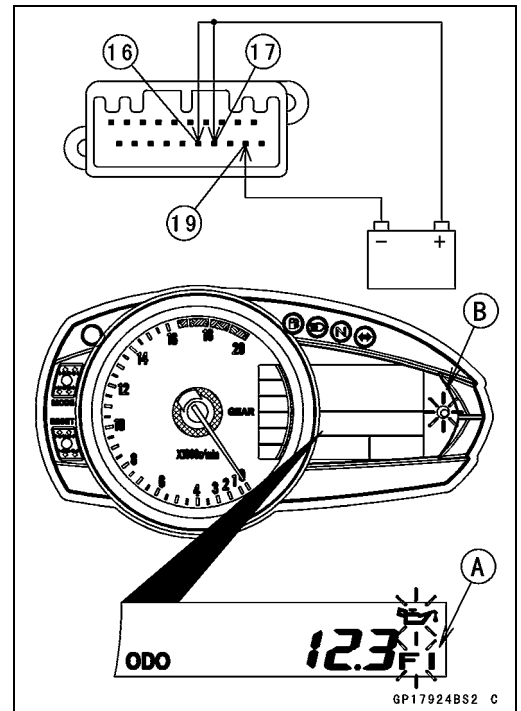

- Set the ODO mode [A] by pushing the MODE button [B].
- Push the MODE button for more than 2 seconds.

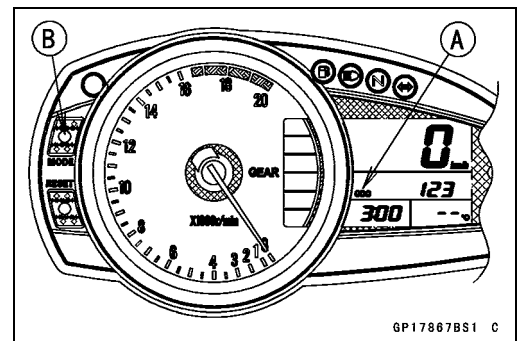

- Check the following items.
  - The number 39 [A] and FI [B] in the display appear and flash.
  - The warning light (LED) [C] flashes.
- Push the MODE button for more than 2 seconds.
- Check the following items.
  - The display returns ODO mode from number 39.
  - The FI in the display and warning light (LED) flash.
- ★ If the meter unit does not work, replace the meter assembly.

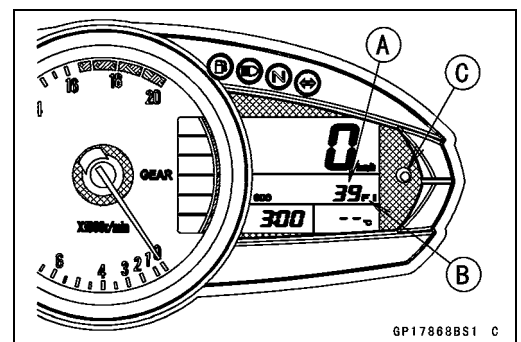

### NOTE

- The number 39 is service code of Self-Diagnosis (see Fuel System chapter). It is the service code of the meter communication line error.
- The number 39 and FI in the display disappear when the meter unit is connected to main harness of the normal motorcycle.

# 16-76 ELECTRICAL SYSTEM

## Meter, Gauge, Indicator Unit

### Check 3: MODE BUTTON Operation Check

● Connect the leads in the same circuit as Check 1.

- Check that the display [A] change to the ODO, TRIP and STOP WATCH displays each time the mode selector button [B] is pressed.
- If the fuel level warning indicator light (LED) blinked [C], display change to FUEL ODO, TRIP and STOP WATCH.
- ★ If the display function does not work, replace the meter assembly.

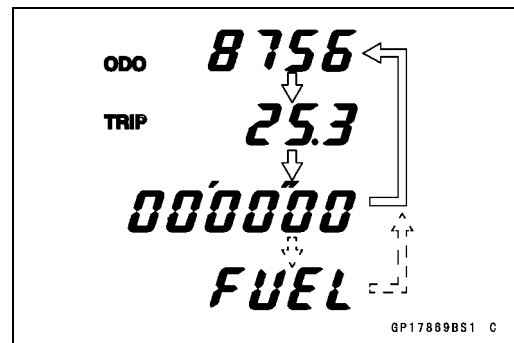
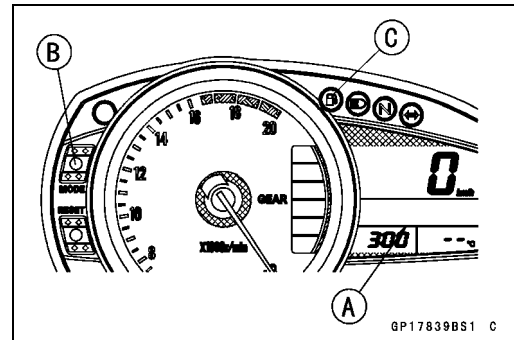
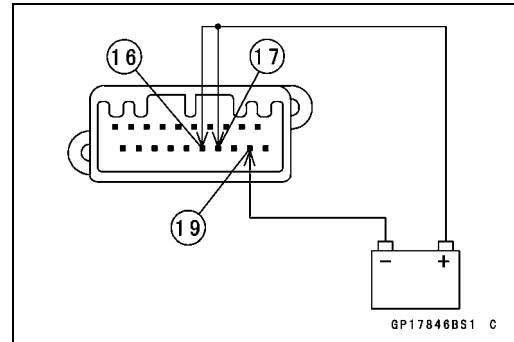

### Check 4: Unit Changing Check

● Connect the leads in the same circuit as Check 1.

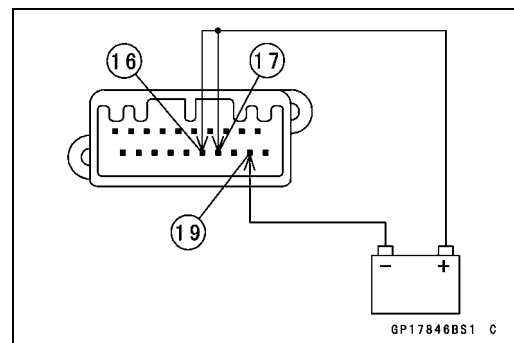

**Meter, Gauge, Indicator Unit**

- Set the ODO mode [A] by pushing the MODE button [B].
- During the MODE button pushing, the unit of the distance [C] and temperature [D] change every time the RESET button [E] is pushed within 2 seconds.
- ★ If the meter function does not work, replace the meter assembly.

**NOTE**

○ Mile/Km Display can alternate between English and metric modes (mile and km) in the digital meter. Make sure that km or mile according to local regulations is correctly displayed before riding.

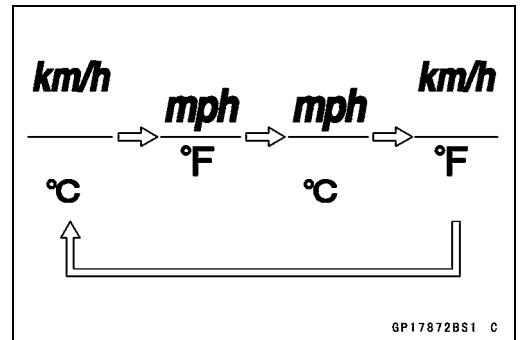
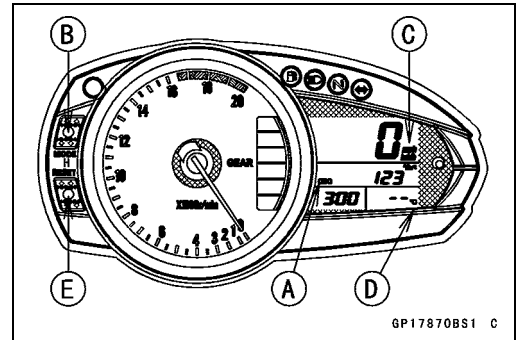

**Check 5: Clock Setting Check**

- Connect the leads in the same circuit as Check 1.

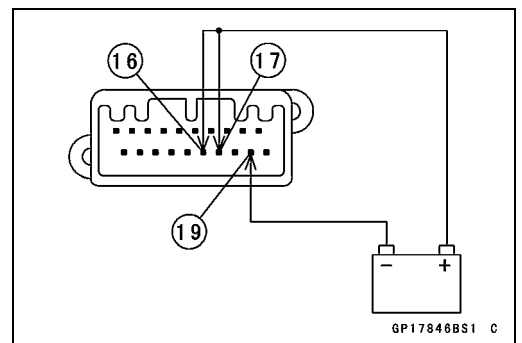

- Set the ODO mode [A] by pushing the MODE button [B].
- Push the REST button [C] for more than two seconds.
- The clock setting menu (hour and minute) [D] should flash.
- Push the RESET button.

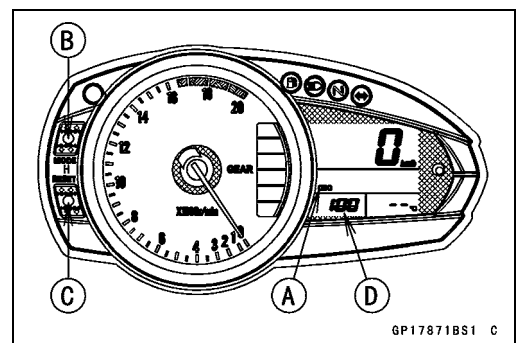

- The hour display [A] starts flashing.
- By pushing the MODE button each time, check that the hour display changes.

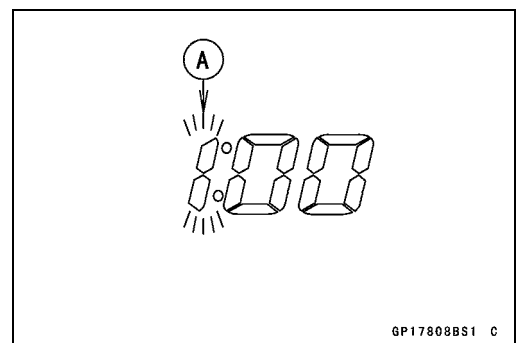

# 16-78 ELECTRICAL SYSTEM

## Meter, Gauge, Indicator Unit

- By pushing the RESET button, check that the hour display decides and minute display [A] starts flashing.
- By pushing the MODE button each time, check that the minute display changes.

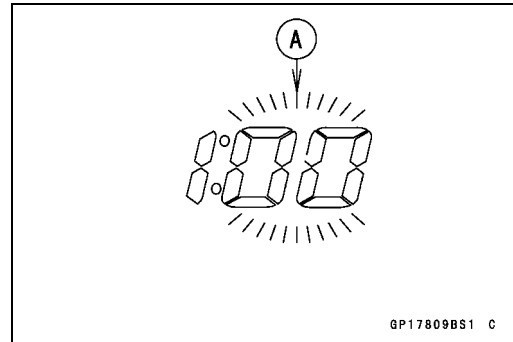

- By pushing the RESET button, check that the hour and minute display start flashing.
- By pushing the MODE button, check that the hour and minute display decide.
- When both hour and minute display is flashing, by pushing the RESET button, check that the hour display start flashing. This flashing returns the hour setting display.
- ★ If the display function does not work, replace the meter assembly.
- If the terminal 15 disconnected when the clock is setting, clock is set at time of that time.

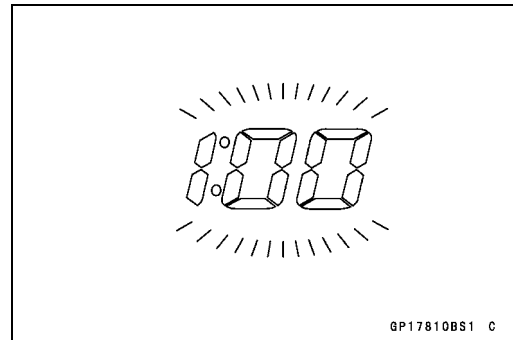

### Check 6: Speedometer Inspection

- Connect the leads in the same circuit as Check 1.
- The speed equivalent to the input frequency is indicated in the oscillator [A], if the square wave (illustrated as shown) would be input into the terminal [13].
- Indicates approximately 60 mph in case the input frequency would be approximately 292.3 Hz.
- Indicates approximately 60 km/h in case the input frequency would be approximately 182.7 Hz.

#### NOTE

- The input frequency of the oscillator adds the integrated value of the odometer.
- The integrated value of the odometer cannot be reset.

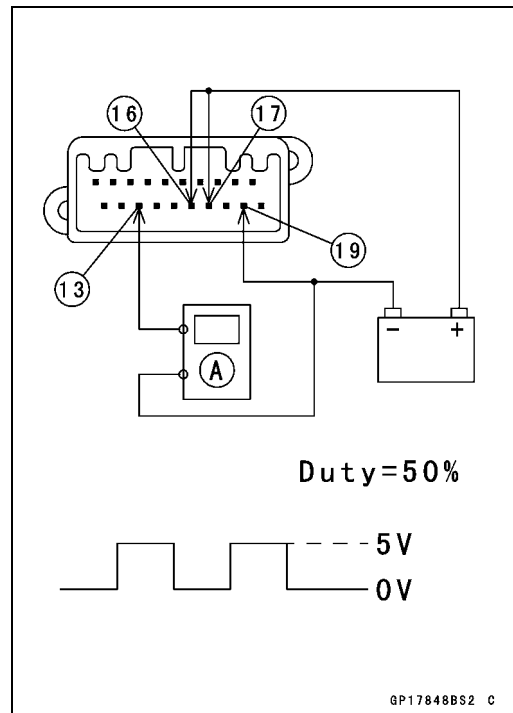

- If the oscillator is not available, the speedometer can be checked as follows.
- Install the meter unit.
- Raise the rear wheel off the ground, using the stand.
- Turn on the ignition switch.
- Rotate the rear wheel by hand.
- Check that the speedometer shows the speed.
- ★ If the speedometer does not work, check the speed sensor electric source voltage and speed sensor.
- ★ The electric source voltage and speed sensor are normal, replace the meter assembly.

## Meter, Gauge, Indicator Unit

### Check 7: Speed Sensor Electric Source Check

- Connect the leads in the same circuit as Check 1.
- Set the hand tester [A] to the DC 25 V range and connect it to the terminals [18] and [19].

#### Electric Source Voltage

**Standard:**            **Approximately 11.5 V at Battery**  
**Voltage 13 V**

- ★ If the voltage is not standard voltage, replace the meter assembly.

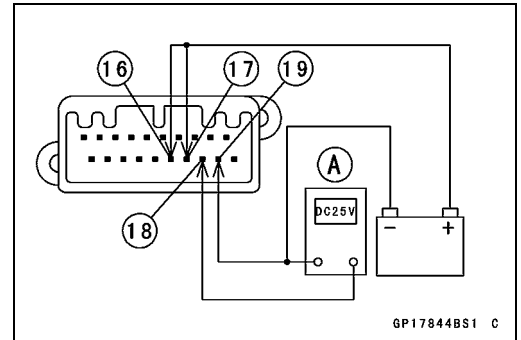

### Check 8: Odometer Inspection

- Connect the leads in the same circuit as Check 6.
- Set the ODO mode [A] by pushing the MODE button [B].
- Raise the input frequency of the oscillator to see the result of this inspection.
- Example: Indicates the increase of approximately 1 km/h, if the input frequency is approximately 182.7 Hz for one minute.
- Example: Indicates the increase of approximately 1 mile, if the input frequency is approximately 292.3 Hz for one minute.
- ★ If the value indicated by the odometer does not increase, replace the meter assembly.

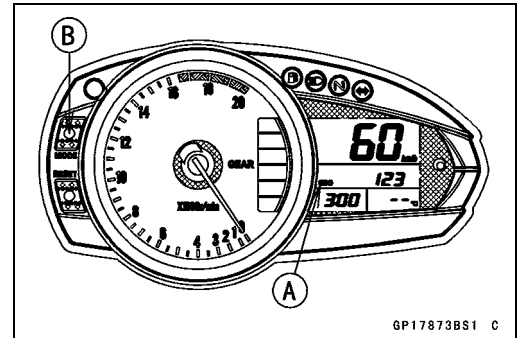

#### NOTE

- The integrated value of the odometer cannot be reset.
- When the figures come to 999999, they are stopped and locked.

### Check 9: Trip Meter Inspection

- Connect the leads in the same circuit as Check 6.
- Set the TRIP mode [A] by pushing the MODE button [B].
- Raise the input frequency of the oscillator to see the result of odometer inspection.
- ★ If the value indicated by the trip meter does not increase, replace the meter assembly.
- When pushing the RESET button [C] for more than two seconds, check that the display changes 0.0.
- ★ If the display function does not change, replace the meter assembly.

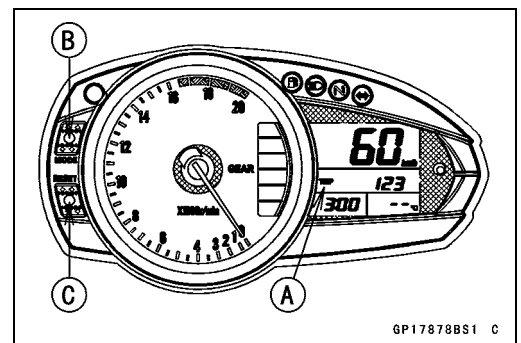

#### NOTE

- The integrated value of the odometer cannot be reset.

### Check 10: Water Temperature Meter Inspection

- Connect the leads in the same circuit as Check 1.
- The "--" indication in the display of the water temperature meter appears.
- Connect the terminal [4] to the battery (-) terminal.

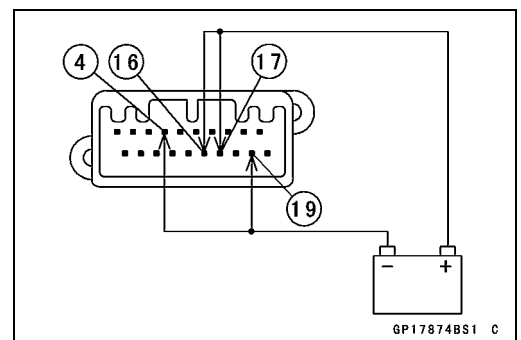

# 16-80 ELECTRICAL SYSTEM

## Meter, Gauge, Indicator Unit

- Check that the display of the water temperature meter [A] changes from “—” to “HI”.
- ★ If the water temperature meter does not work, replace the meter assembly.

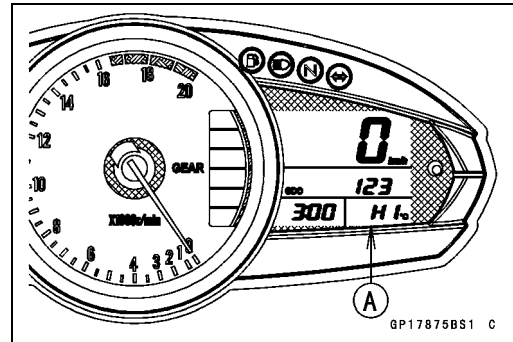

- Connect the resistor [A] (about 210 Ω) to the terminal [4] and the battery (-) terminal.

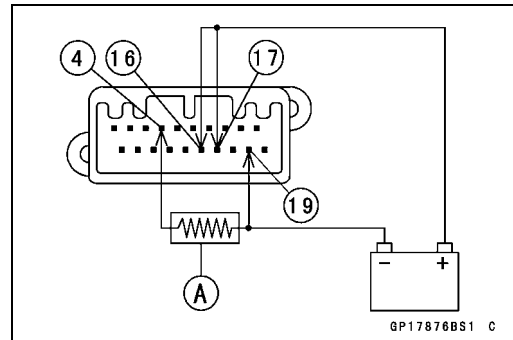

- Check that the display of the water temperature meter [A] indicates approximately 50 °C (122 °F).
- ★ If the water temperature meter does not indicate temperature, replace the meter assembly.

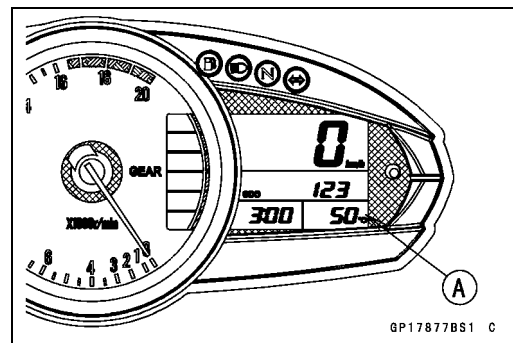

### Check 11: Tachometer Inspection

- Connect the leads in the same circuit as Check 1.
- The revolutions per minute (rpm) equivalent to the input frequency is indicated in the oscillator [A] if the square wave (illustrated as shown) would be input into the terminal [12].
- Indicates approximately 4 000 rpm in case the input frequency would be approximately 133.3 Hz.
- ★ If the meter function does not work, replace the meter assembly.

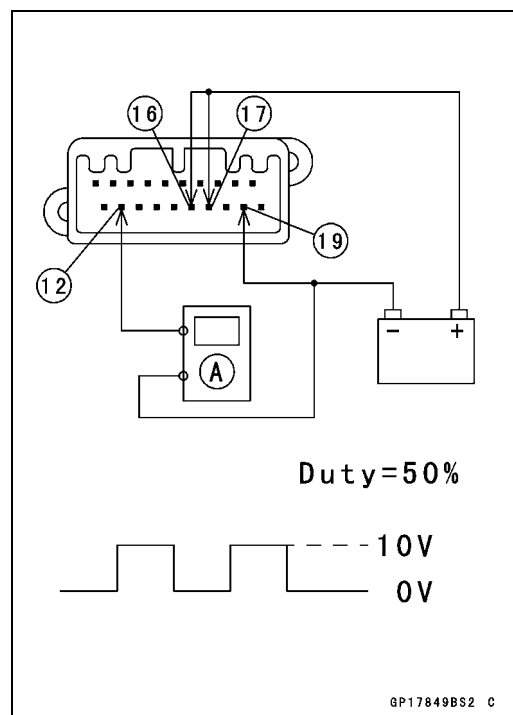



**Meter, Gauge, Indicator Unit**

- Disconnect the terminal [16].
- Check that the tachometer needle [A] back to the minimum (0) position.
- ★ If the meter unit does not work, replace the meter assembly.

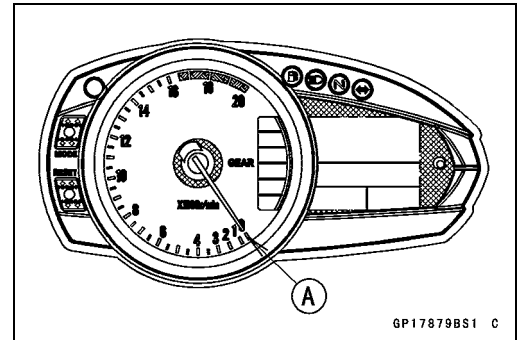

- If the oscillator is not available, the tachometer can be checked as follows.
- Connect the 12 V battery and terminals in the same manner as specified in the “Liquid Crystal Display (LCD) Segments Check”.
- Using an auxiliary lead, quickly open and connect the terminal [12] repeatedly.

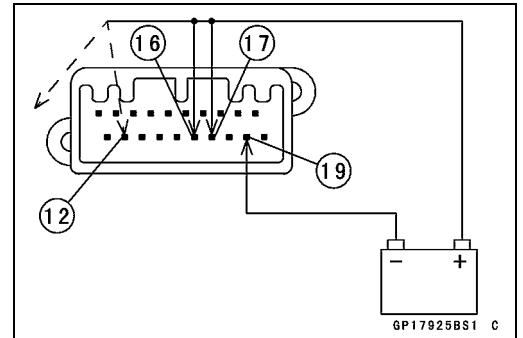

- Then the tachometer needle [A] should flick [B].
- ★ If the needle does not flick, replace the meter assembly.

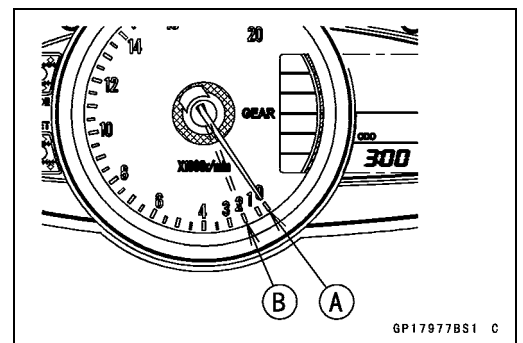

**Check 12: Stop Watch Check**

- Connect the leads in the same circuit as Check 1.
- Press the mode button [A] each time to set the stop watch mode [B].
- Connect the auxiliary lead to the terminal [6] as shown, then stop watch start to count.
- Disconnect the terminal [6] and reconnect it.
- Stop Watch stop to count.

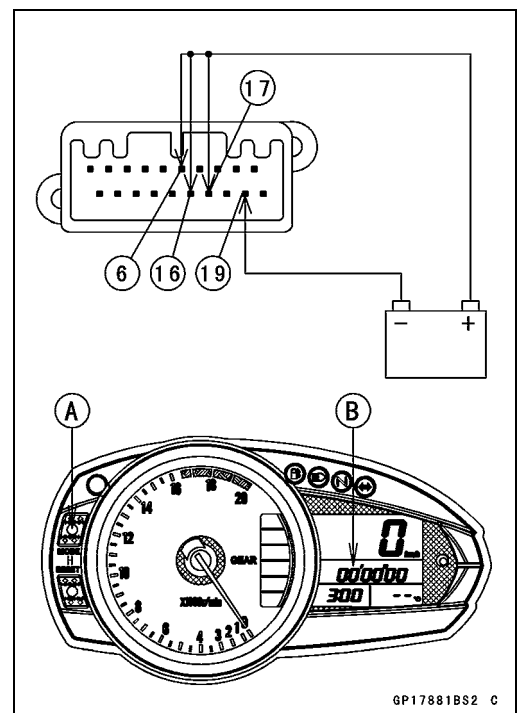

## 16-82 ELECTRICAL SYSTEM

### Meter, Gauge, Indicator Unit

- While count the stop watch, connect the auxiliary lead to the terminal [5] as shown, then indicate the counted time [A] during ten seconds.

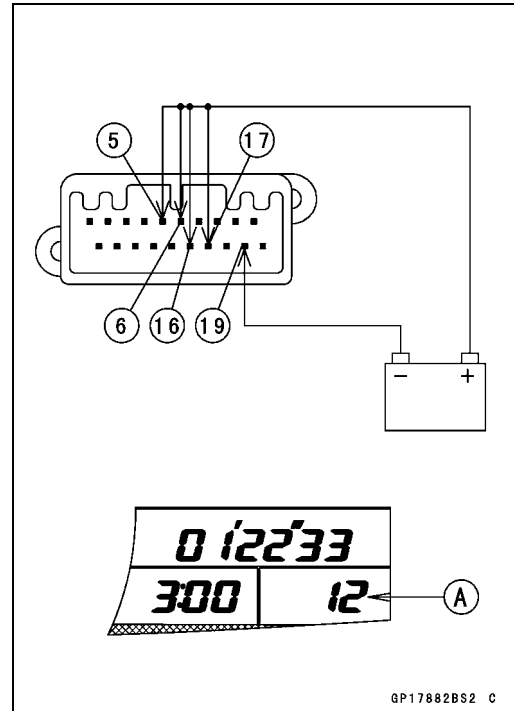

- Check that the meter moves to the lap display stored memory [A] at leaving the button when pushing the RESET button [B] less than 2 seconds while stopping the stop watch.
- ★ If the display function does not work, replace the meter assembly.

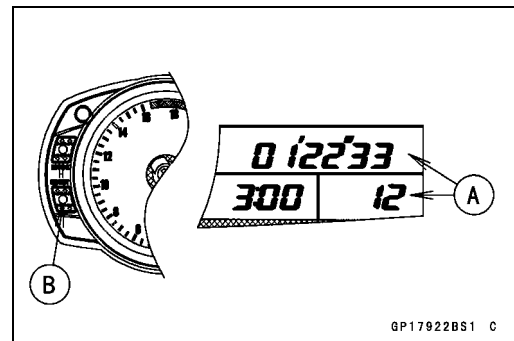

- Check that the all lap time stored memory [A] is clear after 2 seconds passed when pushing the RESET button [B] more than 2 seconds while stop watch display.
- ★ If the memory does not eliminate, replace the meter assembly.

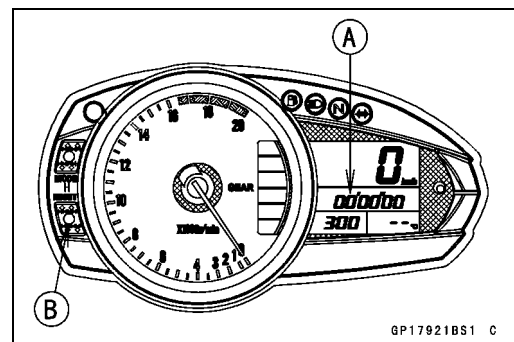

## Meter, Gauge, Indicator Unit

- Check that the stop watch display has 00' 00" 00 display [A], And lap No display has water temperature display [B], when connecting [16] to (+) terminal again, after disconnecting it while operating the stop watch.
- ★ If the display function does not work, replace the meter assembly.

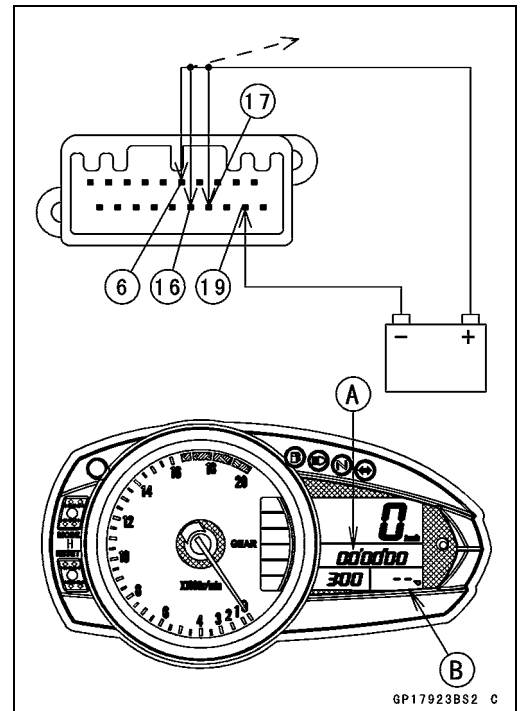

### Check 13: Gear Position Indication Inspection

- Install the meter unit (see Meter Unit Installation).
- Turn the ignition switch ON.
- Check that the N mark neutral indicator light (LED) [A] goes on.

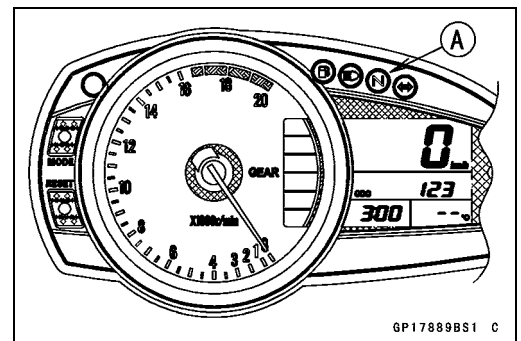

- Set the low gear position, check that the display changes to 1 mark.
- For the other gear position indication;
  - Using the stand, raise the rear wheel off the ground (see Interlock Operation Inspection).
  - Start the engine, change the gear position.
  - Check that the display corresponding to each gear position appears [A].
- Turn the ignition switch OFF.
- ★ If the display function does not work, go to the Check 1 and check the following items.
  - Wiring (see Wiring Inspection)
  - ECU Communication Line Wiring
  - Gear Position Switch (see Gear Position Switch Inspection)
- ★ If the above items are good, replace the meter assembly and/or ECU.

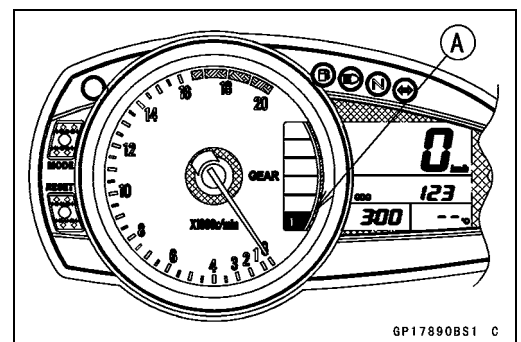

# 16-84 ELECTRICAL SYSTEM

## Meter, Gauge, Indicator Unit

### Check 14: Lights (LED) Inspection

- Connect the leads in the same circuit as Check 1.
  - Neutral Indicator Light (LED) [A]
  - Warning Indicator Light (LED) [B]
  - Turn Signal Indicator Light (LED) [C]
  - High Beam Indicator Light (LED) [D]
  - Fuel Level Warning Indicator Light (LED) [E]
  - Shift Up Indicator Light (LED) [F]
  - Oil Symbol [G]

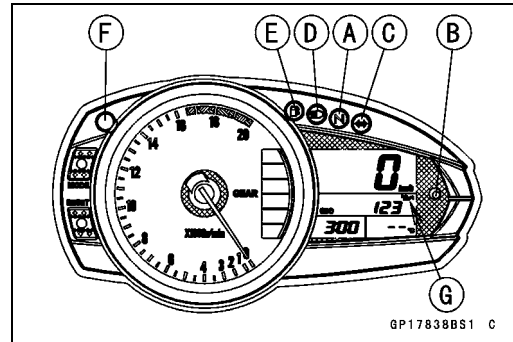

### Neutral Indicator Light (LED)

Battery Negative (-) Terminal To Terminal [1]

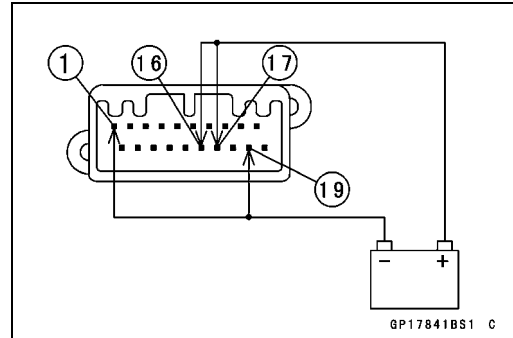

### Oil Symbol and Warning Indicator Light (LED)

Battery Negative (-) Terminal To Terminal [11]

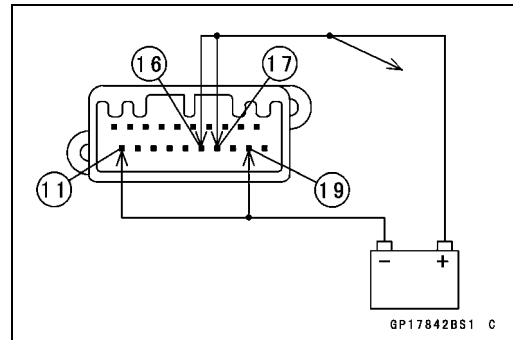

### Right and Left Turn Signal Indicator Light (LED)

Battery Positive (+) Terminal to Terminal [2]  
Battery Positive (+) Terminal to Terminal [10]

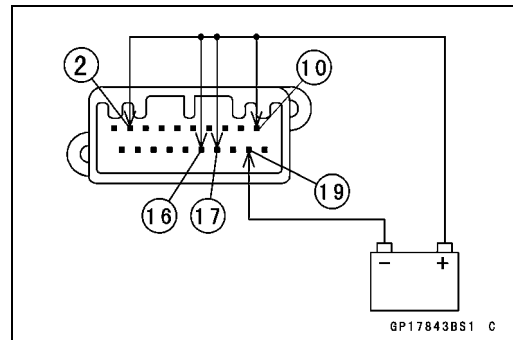

### High Beam Indicator Light (LED)

Battery Positive (+) Terminal to Terminal [3]

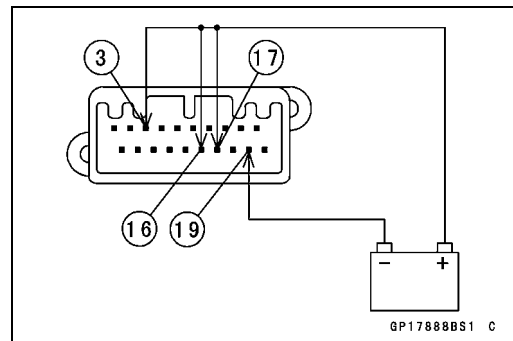

## Meter, Gauge, Indicator Unit

### Check 15: Fuel Level Warning Indicator Light (LED) and Fuel Symbol

- Connect the leads in the same circuit as Check 1.
- The fuel segments flashes in the display.
- Connect a variable rheostat [A] to terminal [15] as shown.
- Adjust the resistance value to the approximately 100  $\Omega$ .
- The fuel level warning indicator light (LED) lists [B] and FUEL segments flashes in the display.

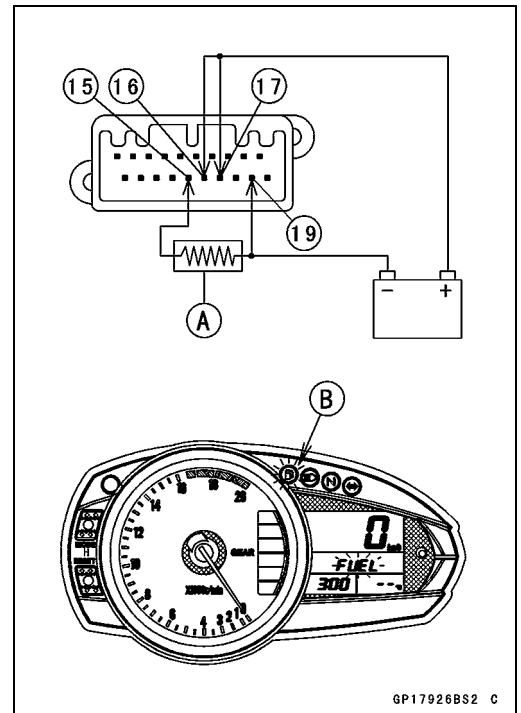

★ If the lights (LED) and/or symbol does not go on, replace the meter assembly.

### Check 16: Immobilizer Flashing Mode Inspection (Equipped Models)

- Connect the leads in the same circuit as Check 1.
- Disconnect the terminal [16].

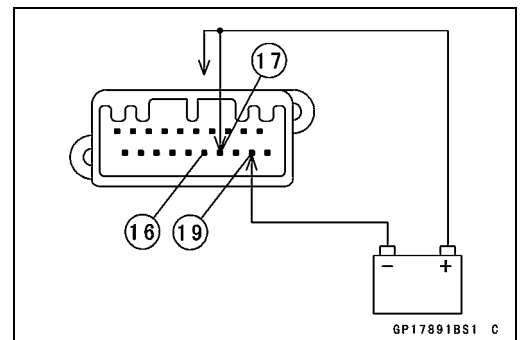

- Check that the warning light (LED) [A] starts flashing (Immobilizer Warning Light Flashing Mode).
- Push the MODE [B] and RESET [C] buttons more than 2 second, within 20 seconds after the terminal [9] disconnected.
- Check that the warning light (LED) goes on one second, and then the light goes off (Immobilizer Warning Light No Flashing Mode).

#### NOTE

- For this inspection, be sure the battery is 12.2 V or more.
- Immobilizer Warning Light Flashing Mode does not work, when the battery voltage is less than 12  $\pm$ 0.2 V.

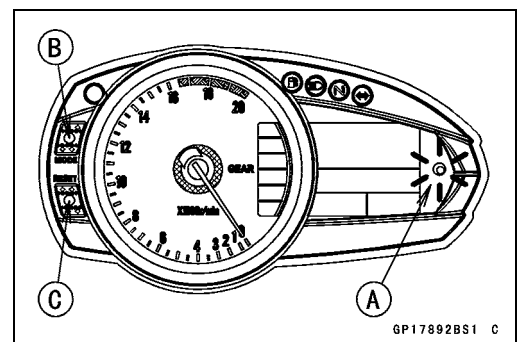

# 16-86 ELECTRICAL SYSTEM

## Meter, Gauge, Indicator Unit

- Connect the terminal [16] to the battery (+) terminal.
- And then, disconnect the terminal [16].
- Push the MODE and RESET buttons more than 2 second, within 20 seconds after the terminal [9] disconnected.
- Check that the warning light (LED) goes on one second, and then the light starts flashing (Immobilizer Warning Light Flashing Mode).
- ★ If the meter function does not work, replace the meter assembly.

### Check 17: Shift Up Indicator Light (LED)

- Connect the leads in the same circuit as check 1.
- When pushing the MODE button [A] and RESET button [B] simultaneously for more than 2 seconds, the shift up indicator [C] goes on at pre-set light mode after 2 seconds passed, tachometer meter needle [D] indicates the current pre-set engine speed and check to move to the setting mode.
- ★ If the needle and light does not work, replace the meter assembly.

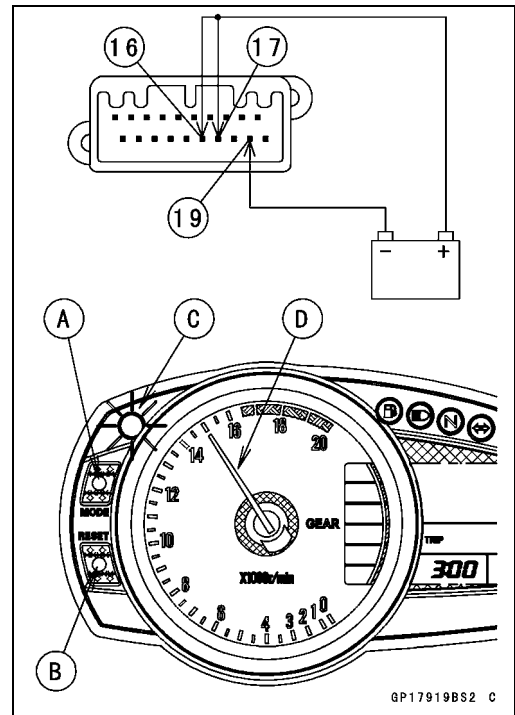

- When changing the pre-set engine speed, check that the tachometer meter needle moves (change of pre-set engine speed) within the adjusting range by pushing the RESET button.

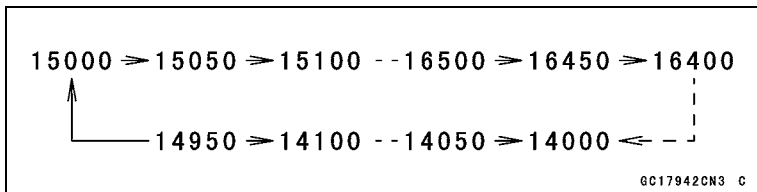

- When changing the pre-set engine speed, check that the light mode of the shift up indicator changes at the MODE button released after MODE button is pushed in less than 2 seconds.

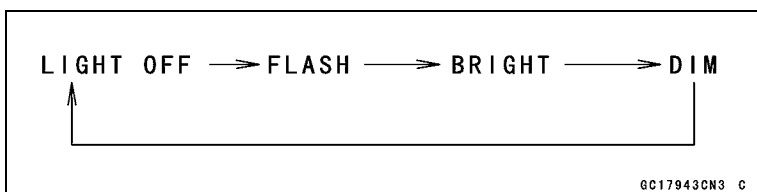

- ★ If the display function does not work, replace the meter assembly.

## Meter, Gauge, Indicator Unit

- When changing the pre-set engine speed, push the MODE button [A] and RESET button [B] simultaneously for more than 2 seconds, and engine speed and light mode setting complete after 2 seconds passed, then check to go back to the mode before moving to this setting [C] mode.
- ★ If the needle and light does not work, replace the meter assembly.

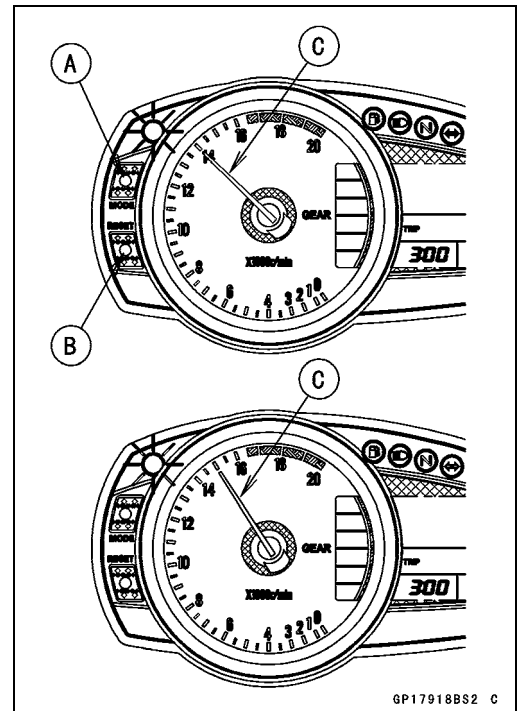

- When (+) terminal [16] is disconnected from batter positive terminal under changing the shift up indicator setting, and it connected again, check that pre-set engine speed and light mode finish under setting.
- ★ If the display function does not work, replace the meter assembly.

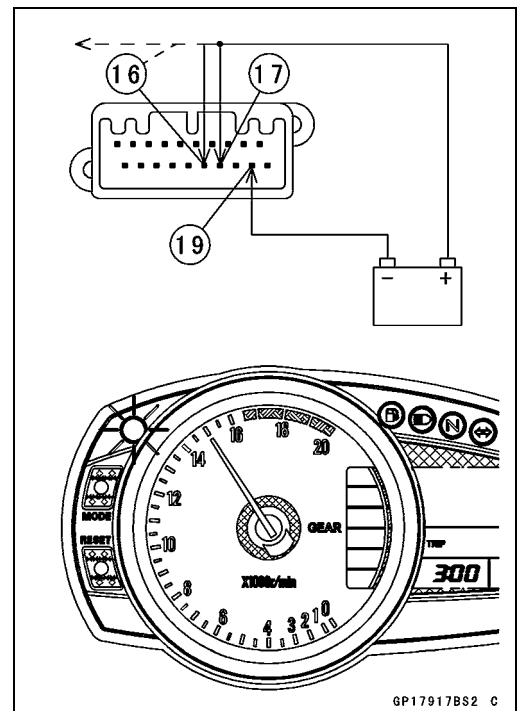

# 16-88 ELECTRICAL SYSTEM

## Meter, Gauge, Indicator Unit

- The speed equivalent to the input frequency is indicated in the oscillator if the square wave (illustrated as shown) would be input into the terminal.
- When inputting the signal of the oscillator with more than 1 km/h (mph) or equivalent into the terminal [13], check to operate normally.
- When inputting the signal of the oscillator with more than 1 km/h (mph) or equivalent into the terminal [13], check the pre-set engine speed and light mode does not move to the setting mode.
- ★ If the display function does not work, replace the meter assembly.

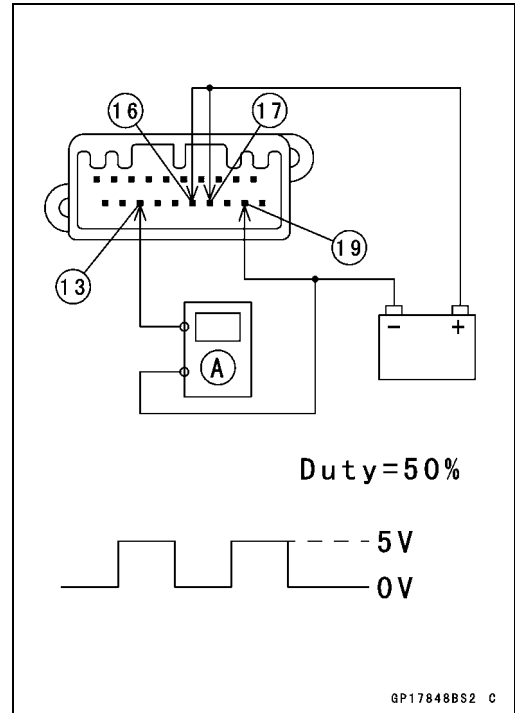

- The revolutions per minute (rpm) equivalent to the input frequency is indicated in the oscillator [A] if the square wave (illustrated as shown) would be input into the terminal [12].
- When set the oscillator more than 550 Hz, shift up indicator light (LED) go on.

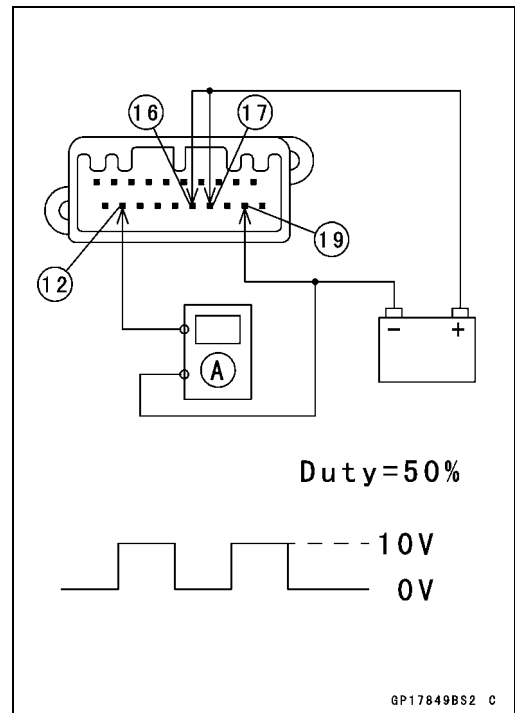

- ★ If each LED lights does not go on, replace the meter assembly.



---

**Meter, Gauge, Indicator Unit**

---

**Fuel Level Sensor Line Self-Diagnosis Mode Inspection****NOTE**

- Usually when the open or short of the fuel level sensor circuit is detected, it becomes the Fuel Level Sensor Line Self-Diagnosis Mode.
- The fuel level warning indicator light [A] and FUEL [B] in the display will flash. (This function is Fuel Level Sensor Line Self-Diagnosis Mode.)
- ★ If the meter enters the self-diagnostic mode when the meter is installed in the motorcycle, check the fuel reserve switch (see Fuel Reserve Switch Inspection) and wiring.
- ★ If the fuel reserve switch and wiring are good, replace the meter assembly.

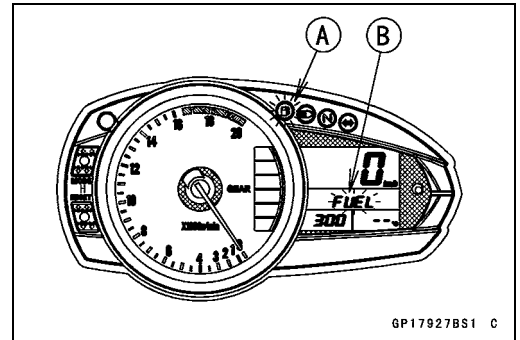

# 16-90 ELECTRICAL SYSTEM

## Meter, Gauge, Indicator Unit

### Meter Circuit

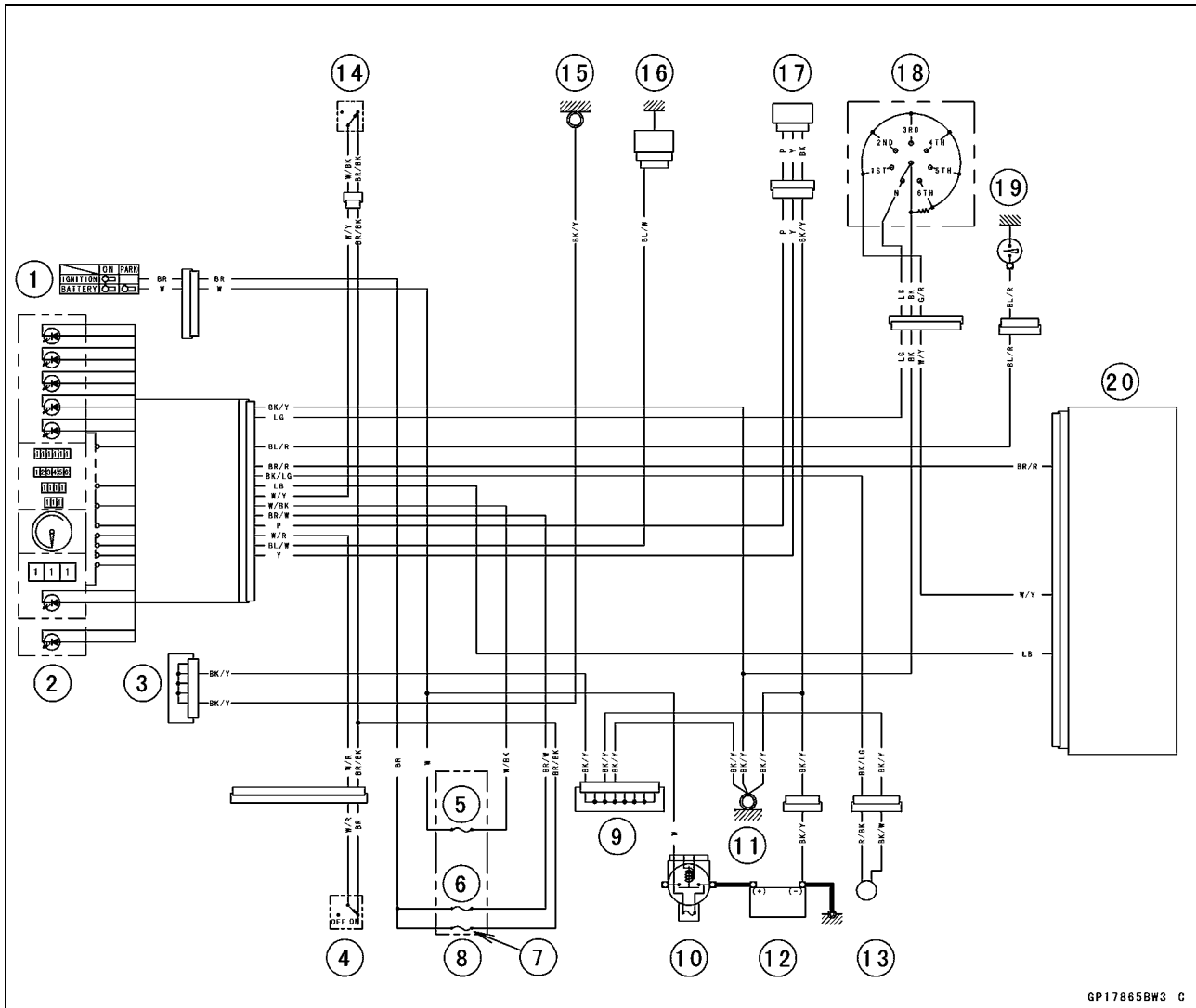

GP17865BW3 C

1. Ignition Switch
2. Meter Unit
3. Joint Connector C
4. Lap Switch
5. ECU Fuse 10 A
6. Ignition Fuse 10 A
7. Horn Fuse 10 A
8. Fuse Box
9. Joint Connector B
10. Main Fuse 30 A
11. Frame Ground
12. Battery 12 V 8 Ah
13. Fuel Reserve Switch
14. Stop Watch Switch
15. Cylinder Head Cover Ground
16. Water Temperature Sensor
17. Speed Sensor
18. Gear Position Switch
19. Oil Pressure Switch
20. ECU

## Immobilizer System (Equipped Models)

This motorcycle is equipped with an immobilizer system to protect the motorcycle from theft. This system provides a theft proof device by means of matching a code between the inbuilt key transponder and ECU (Electronic Control Unit). If the code does not match, ignition system, injectors, subthrottle valve actuator and exhaust butterfly valve actuator will not operate and the engine will not start.

### Abstract

- Do not keep more than one immobilizer key of any system on a key ring. Jamming of the key code signal may occur and the operation of the system may be affected.
- The warning indicator light (LED) will flash for a period of 24 hours once the ignition switch has been switched OFF and the key removed. This flashing can be set to on or off as desired by holding the Mode and Reset buttons down for two seconds within twenty seconds of switching the ignition off.
- If all coded keys (master key and user keys) are lost the ECU and ignition switch will have to be replaced.
- The immobilizer system can not function until the master key code is registered in the ECU.
- A total of six keys can be registered in the ECU at any one time (one master key and five user keys).
- If the master key is lost it is not possible to register new user keys.

### Operational Cautions

1. Do not put two keys of any immobilizer system on the same key ring.
2. Do not submerge any key in water.
3. Do not expose any key to excessively high temperature.
4. Do not place any key close to magnet.
5. Do not place a heavy item on any key.
6. Do not grind any key or alter its shape.
7. Do not disassemble the plastic part of any key.
8. Do not drop the key and/or apply any shocks to the key.
9. When a user key is lost, the user should go to his dealer to invalidate the lost key registration in the electronic control unit (ECU).
10. When the master key is lost, the user should go to his dealer and have a new ECU installed and register a new master key and user keys.

### NOTE

○No.9 and 10 are strongly recommended to the customer to ensure security of the motorcycle.

### Key Registration

**Case 1: When the user key has been lost or additional spare user key is required.**

- Prepare a new spare user key.
- Cut the key in accordance with the shape of the current user key.
- Remove:
  - Front Seat (see Front Seat Removal in the Frame chapter)
- Disconnect the immobilizer/Kawasaki self-diagnosis system connector [A].

- Connect the key registration unit [A].

**Special Tool - Key Registration Unit: 57001-1582**



# 16-92 ELECTRICAL SYSTEM

## Immobilizer System (Equipped Models)

- Insert the master key to the ignition switch and turn it ON.

### Verified

- The warning indicator light (LED) [A] blinks to display the registration mode (go to the next step).

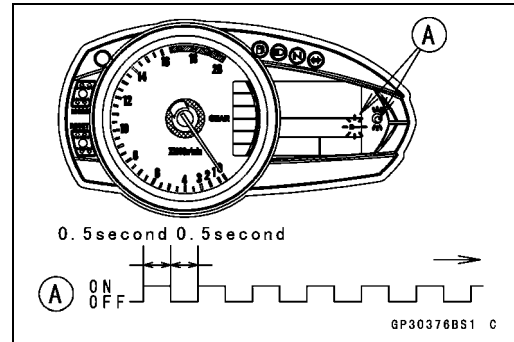

### Not Verified

- The Warning indicator light (LED) [A] blinks to display the collation error (refer to the following failure illustrations).  
Immobilizer Amplifier Failure

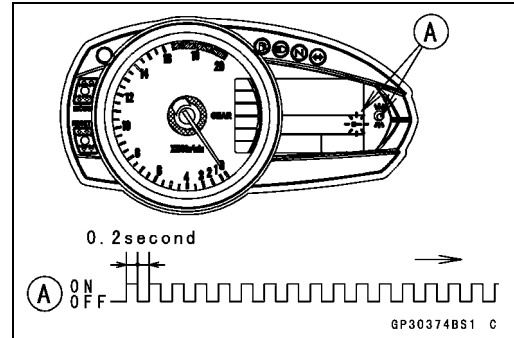

Master Key Collation Error

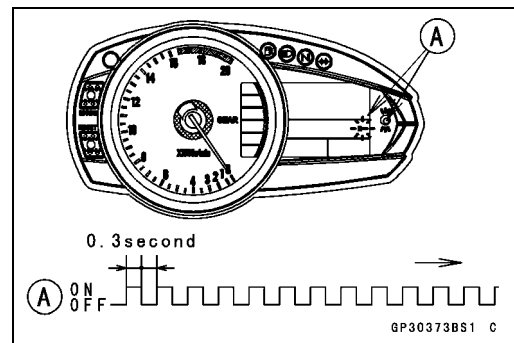

- Turn the master key OFF and remove the master key.
- The warning indicator light (LED) [A] blinks continuously to display that the ECU is in the registration mode for 15 seconds.

### NOTE

○ Insert next key and turn ON within 15 seconds after previous key is turned off and removed otherwise registration mode will be ended and the warning indicator light (LED) stops flashing.

○ To return to the registration mode start the master key verification procedure. This applies to all user key registration.

- Insert the user key 1 to the ignition switch and turn it ON.

### NOTE

○ Keep the other user key away from the immobilizer antenna.

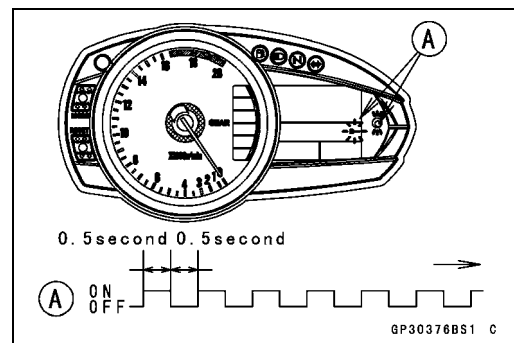

## Immobilizer System (Equipped Models)

- If there is any problem in the registration, the warning indicator light (LED) [A] blinks to display the collation error. Immobilizer Amplifier Failure

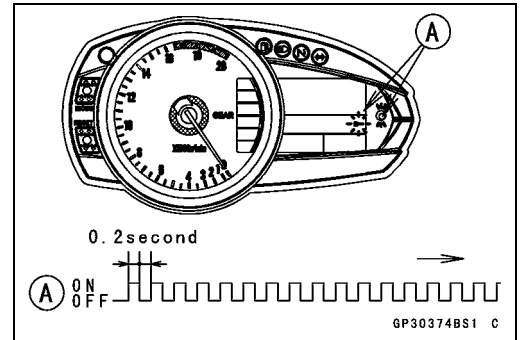

When Registered User Key is Inserted.

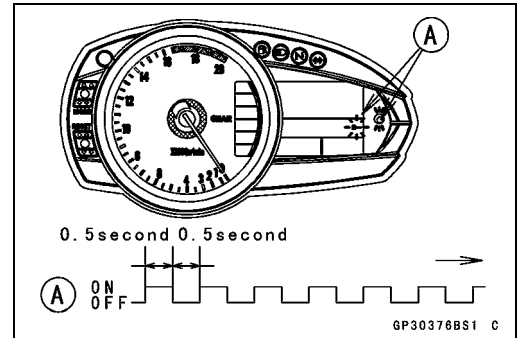

User Key Collation Error

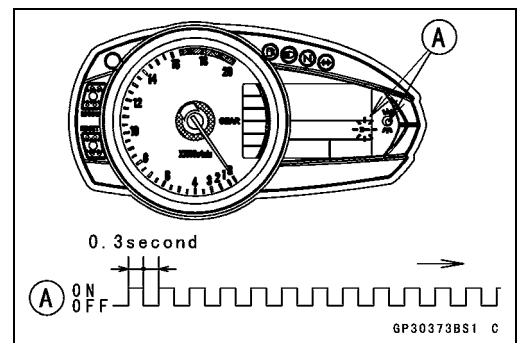

- The user key 1 is successfully registered in the ECU.
- The warning indicator light (LED) [A] blinks 2 times and stops for 1 second and then repeats this cycle.

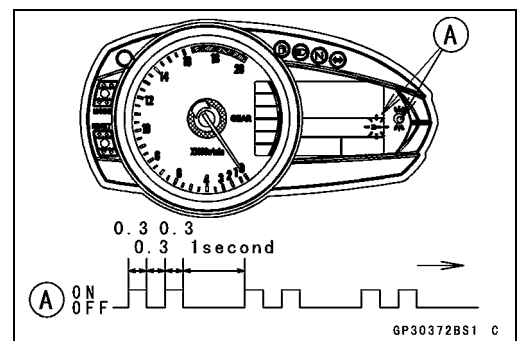

- Turn the user key 1 OFF and remove off the user key 1.
- The warning indicator light (LED) [A] blinks to display the registration mode.

### NOTE

- Turn off the ignition switch and wait for the period of 15 seconds or more. The registration mode automatically finishes and the warning indicator light (LED) will switch off.
- This procedure registered the master key and one user key.
- Continue with the procedure to register the second and later keys before the 15 seconds period has elapsed.

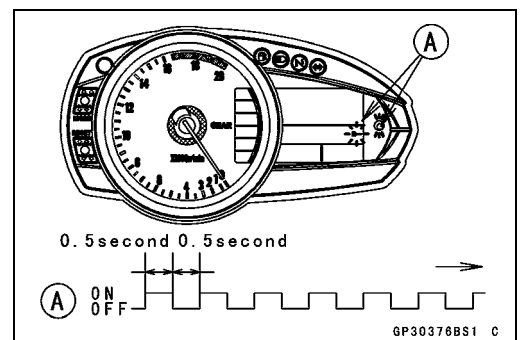

# 16-94 ELECTRICAL SYSTEM

## Immobilizer System (Equipped Models)

- Insert the user key 2 to the ignition switch and turn it ON.
- If there is any problem in the registration, the warning indicator light (LED) [A] blinks to display the collation error.  
Immobilizer Amplifier Failure

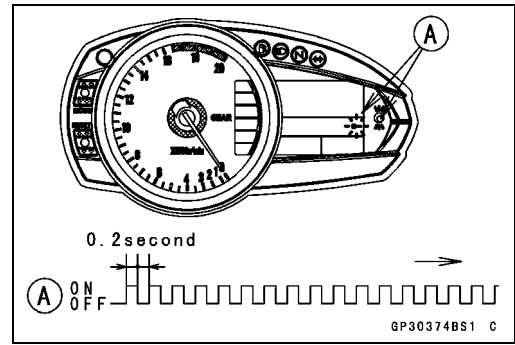

When Registered User Key is Inserted.

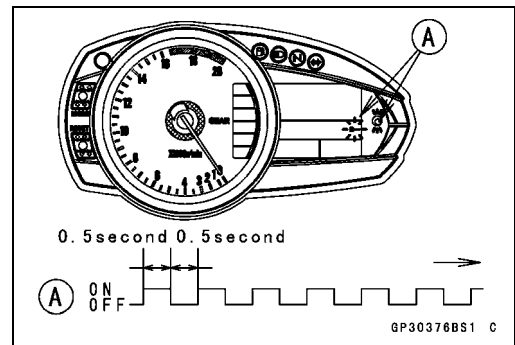

User Key Collation Error

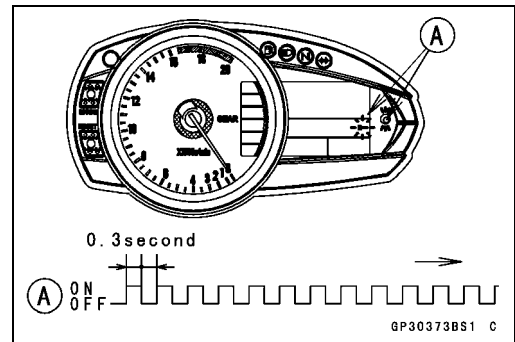

- The user key 2 is registered in the ECU.
- The warning indicator light (LED) [A] blinks 3 times and stops for 1 second and then repeats this cycle.
- This procedure has registered the master key and 2 user keys.
- Continue with the procedure to register an additional 3 user keys.

### NOTE

○ The ECU can store up the six key codes (master key x 1 and user key x 5).

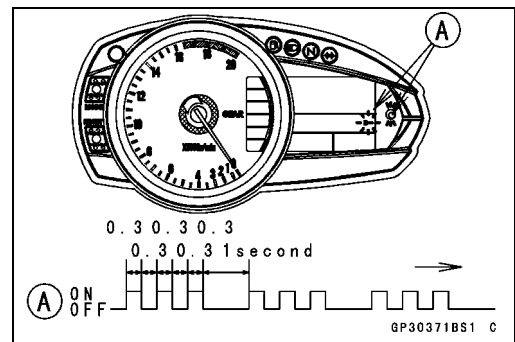

### User Key Indicator Flashes

	Warning Indicator Light (LED) Blinks	Warning Indicator Light (LED) Stop	Remarks
User Key 3	4 times	1 seconds	Repeat
User Key 4	5 times	1 seconds	Repeat
User Key 5	6 times	1 seconds	Repeat

- Turn OFF the ignition switch and wait for period of more than 15 seconds.
- The registration mode automatically ends.

## Immobilizer System (Equipped Models)

- FI indicator light goes off [A].

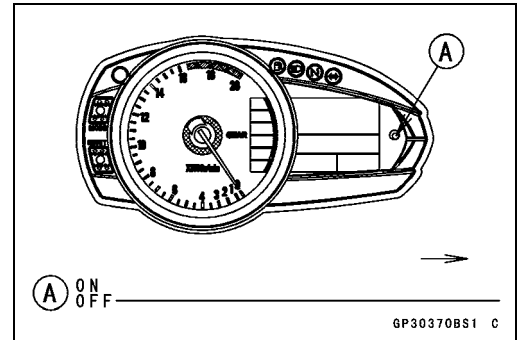

- Remove the key registration unit and connect the immobilizer/Kawasaki self-diagnostic system connector.

### NOTE

- Turn the ignition switch ON with the registered user key.
- Check that the engine can be started using all registered user keys.

# 16-96 ELECTRICAL SYSTEM

## Immobilizer System (Equipped Models)

### Spare User Key Registration Flow Chart

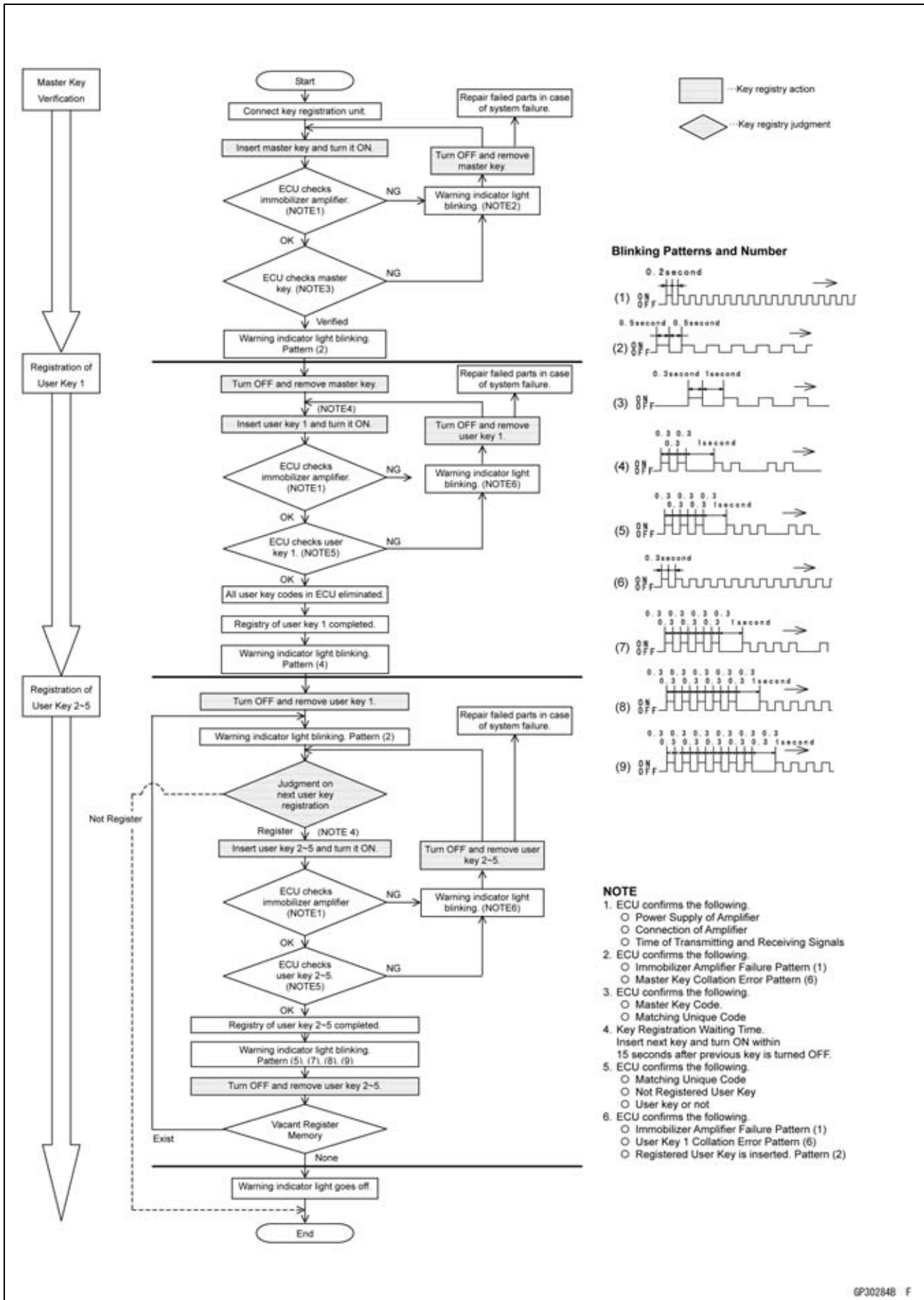



**Immobilizer System (Equipped Models)**

**Case 2: When the ignition switch is faulty and to be replaced.**

- Prepare a new ignition switch [A] and two new user keys [B].
- These parts are available as a set. Prepare the current master key [C].

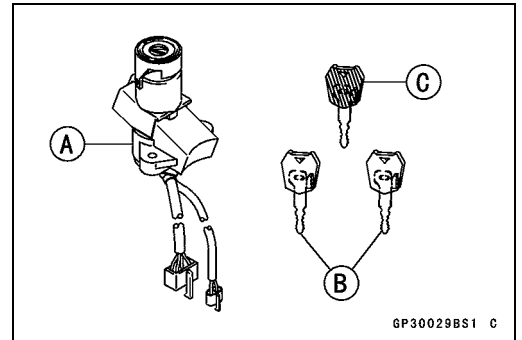

- Remove:
    - Ignition Switch and Immobilizer Antenna (see Immobilizer System Parts Replacement)
    - Front Seat (see Front Seat Removal in the Frame chapter)
  - Disconnect the immobilizer/Kawasaki self-diagnostic system connector.
  - Connect the key registration unit [A].
- Special Tool - Key Registration Unit: 57001-1582**

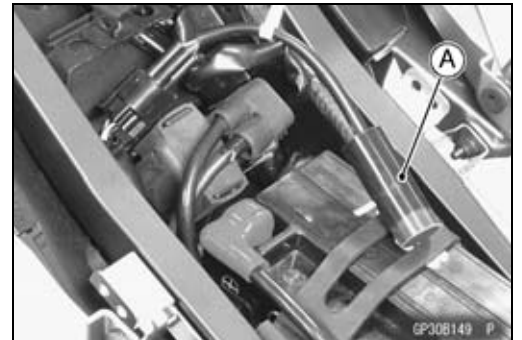

- Connect:
  - New Ignition Switch Lead Connector [A]
  - Immobilizer Antenna Lead Connector [B]

**NOTE**

○ Keep the antenna more than 15 cm from the ignition switch.

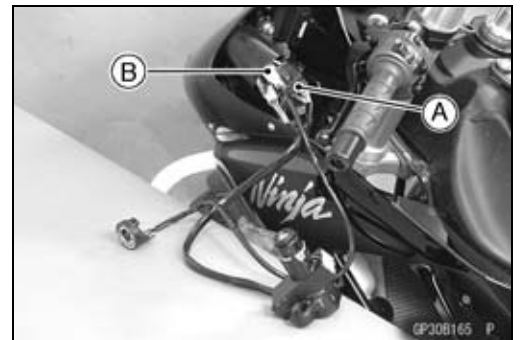

- Put the current master key [A] at the antenna [B]. Insert the new user key 1 [C] to the new ignition switch [D] and turn it ON.

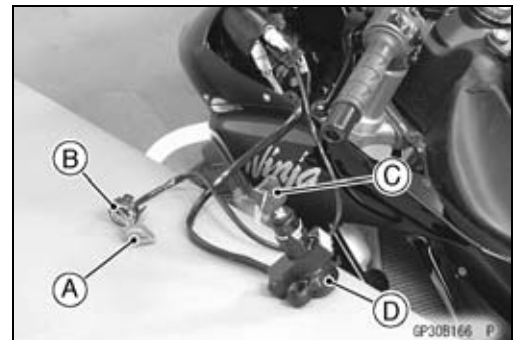

**Verified**

○ The warning indicator light (LED) [A] blinks to display the ECU is in the registration mode (go to the next step).

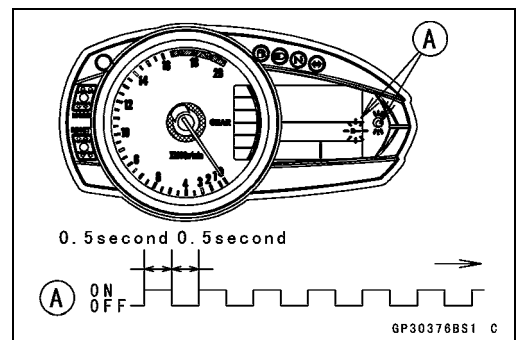

## 16-98 ELECTRICAL SYSTEM

### Immobilizer System (Equipped Models)

#### Not Verified

○The warning indicator light (LED) [A] blinks to display the collation error.

Immobilizer Amplifier Failure

Master Key Collation Error

- Turn off and remove the new user key 1.
- Temporarily place the antenna [A] on the new ignition switch [B].
- Insert the user key 1 [C] again into the new ignition switch and turn it ON.

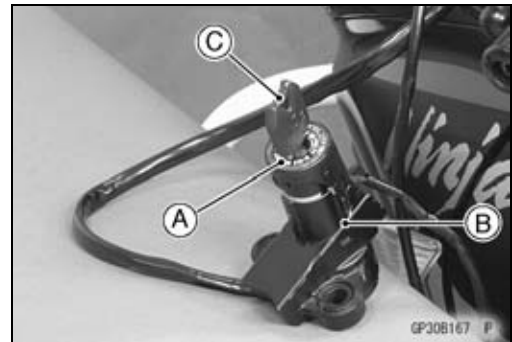
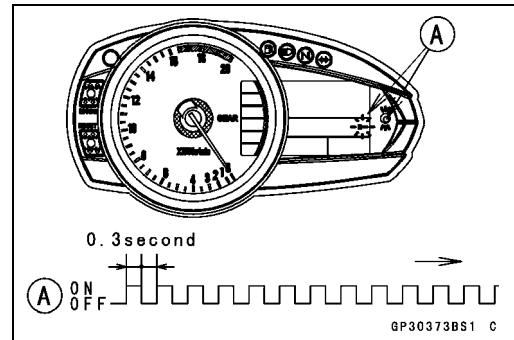
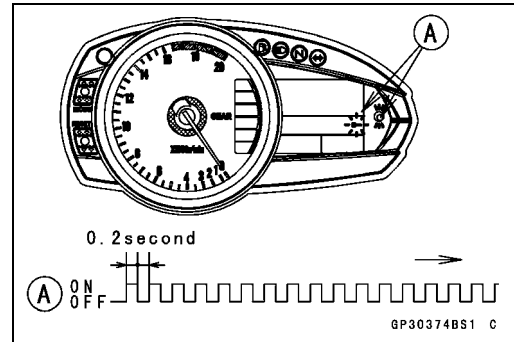

#### NOTE

- Place the antenna on the ignition switch, insert the next key and turn ON within 15 seconds after previous key is turned off and removed otherwise registration mode will be ended and the warning indicator light (LED) stops flashing.
- To return to the registration mode start the master key verification procedure. This applies to all user key registration.
- Keep other user keys away from the immobilizer antenna.

## Immobilizer System (Equipped Models)

- If there is any problem in the registration, the warning indicator light (LED) [A] blinks to display the collation error. Immobilizer Amplifier Failure

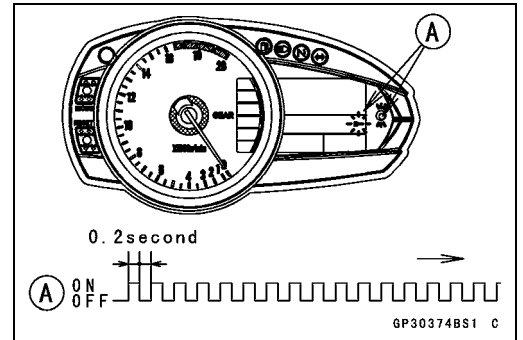

When Registered User Key is Inserted.

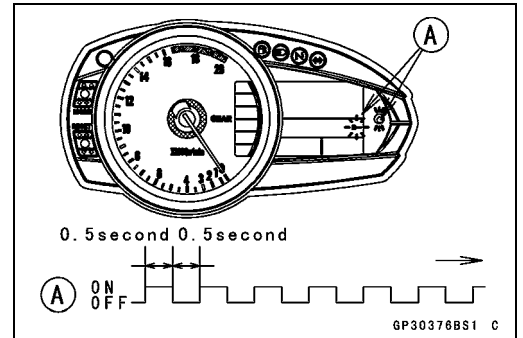

User Key Collation Error

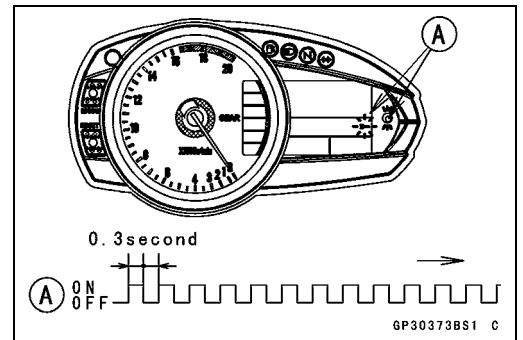

- The user key 1 is successfully registered in the ECU.
- The warning indicator light (LED) [A] blinks 2 times and stops for 1 second and then repeats this cycle to indicate successful registering of user key 1.

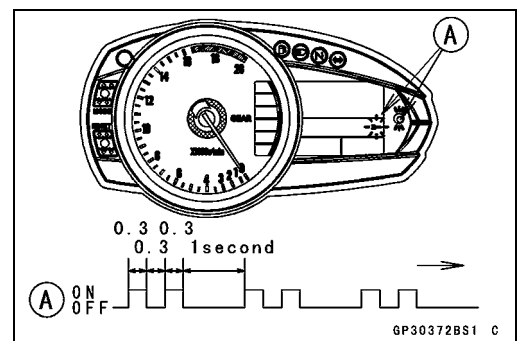

- Turn off and remove user key 1.
- The warning indicator light (LED) [A] blinks to display the registration mode.

### NOTE

- Turn off the ignition switch and wait for the period more than 15 seconds. The registration mode automatically ends and warning indicator light goes off.
- This procedure has , registered the master key and one user key.
- Continue the procedure to program the second and later keys.

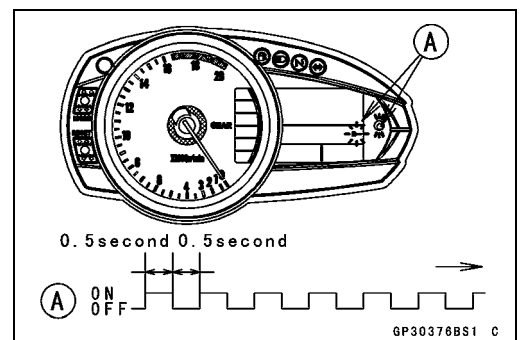

- Insert the user key 2 to the ignition switch and turn it ON.

# 16-100 ELECTRICAL SYSTEM

## Immobilizer System (Equipped Models)

○ If there is any problem in the registration, the warning indicator light (LED) [A] blinks to display the collation error.  
Immobilizer Amplifier Failure

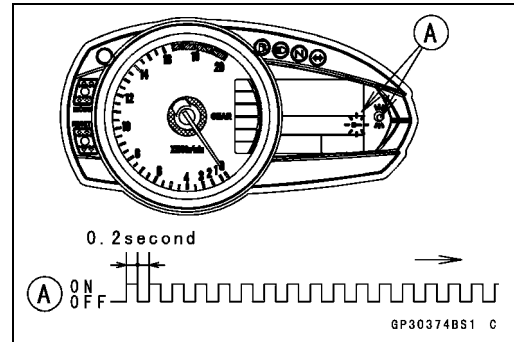

When Registered User Key is Inserted.

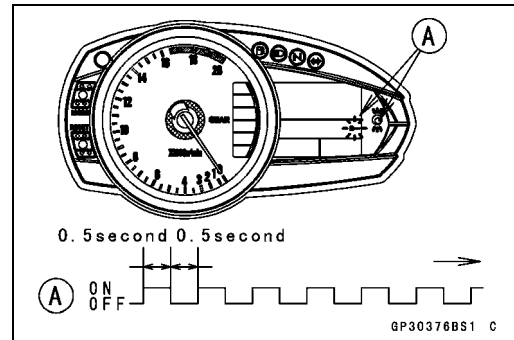

User Key Collation Error

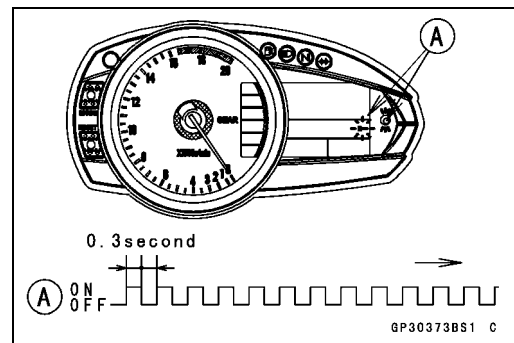

- The user key 2 is successfully registered in the ECU.
- The warning indicator light (LED) [A] blinks 3 times and stops for 1 second and then repeat this cycle to indicate successful programming of user key 2.
- Turn OFF the ignition switch and wait for period more than 15 seconds.
- The registration mode automatically ends.

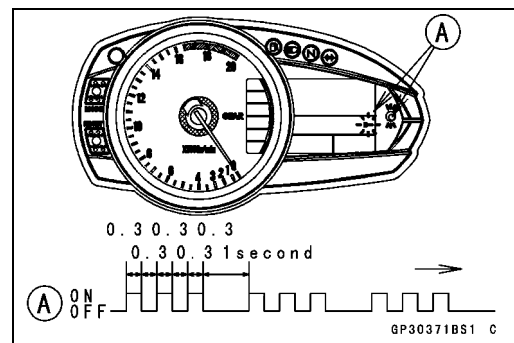

- FI indicator light goes off [A].

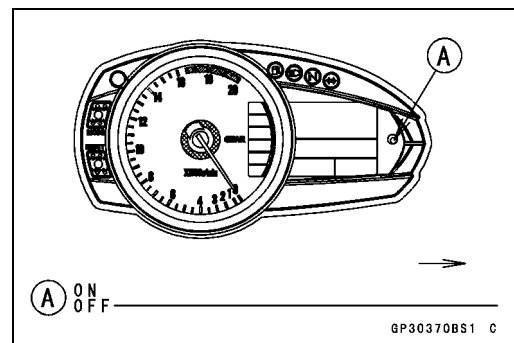

**Immobilizer System (Equipped Models)**

- Remove the key registration unit and connect the immobilizer/Kawasaki self-diagnostic system connector.

**NOTE**

- Turn the ignition switch ON with the registered user key.
- Check that the engine can be started using all registered user keys.

- Install the new ignition switch and antenna.

**Case 3: When the electric control unit (ECU) is faulty and has to be replaced.**

- Prepare a new ECU [A], current master key [B] and current user keys [C].

**NOTE**

- The key registration unit is not required.

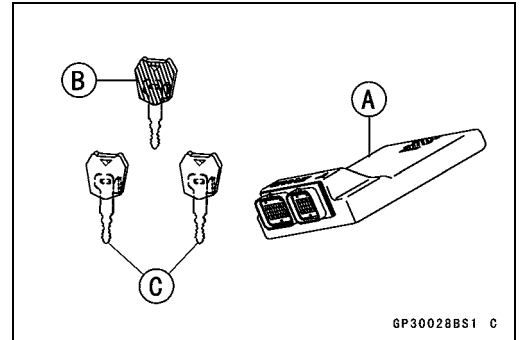

GP30028BS1 C

- Replace:  
Electric Control Unit [A] (see ECU Removal in the Fuel System (DFI) chapter)

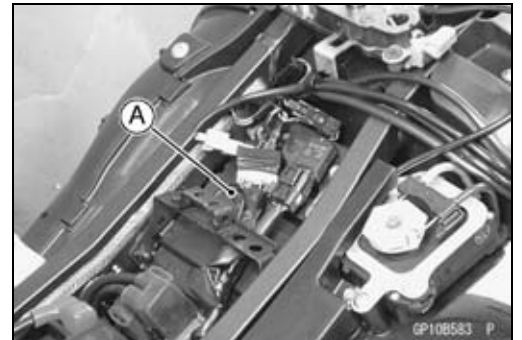

GP10B5B3 P

- Insert the current master key into the ignition switch and turn it ON.

- If there is any problem in the registration, the warning indicator light (LED) [A] blinks to display the collation error. Immobilizer Amplifier Failure

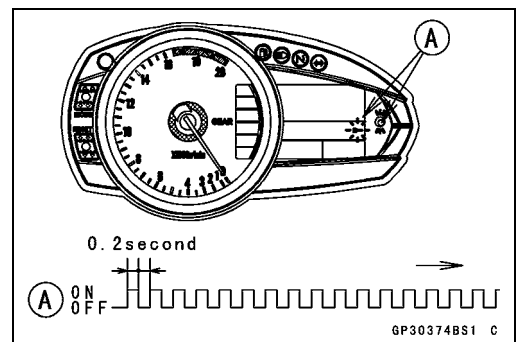

GP30374BS1 C

Master Key Collation Error

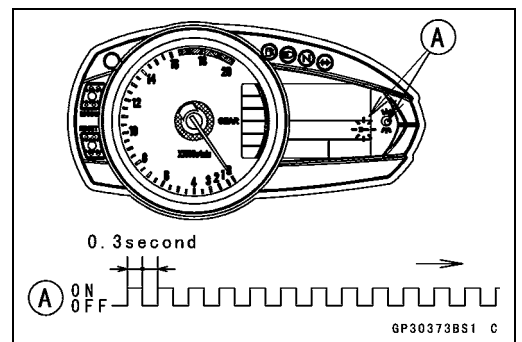

GP30373BS1 C

# 16-102 ELECTRICAL SYSTEM

## Immobilizer System (Equipped Models)

- The master key is registered in the ECU.
- The warning indicator light (LED) [A] blinks 1 time and stops for 1 second and the repeats this cycle to indicate successful registration of the master key.

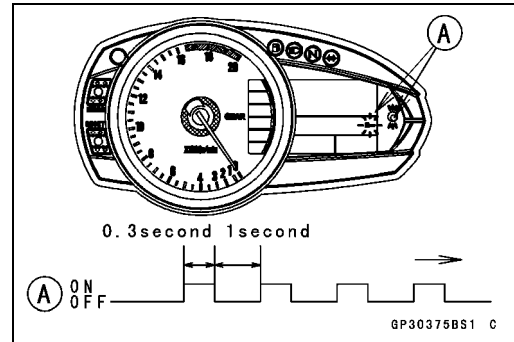

- Turn of the master key and remove it.
- The warning indicator light (LED) [A] blinks to display the registration mode.

### NOTE

- Insert next key and turn ON within 15 seconds after previous key is turned off and removed otherwise registration mode will be ended and the warning indicator light (LED) goes off.
- To return to the registration mode start the master key verification procedure. This applies to all user key registration.

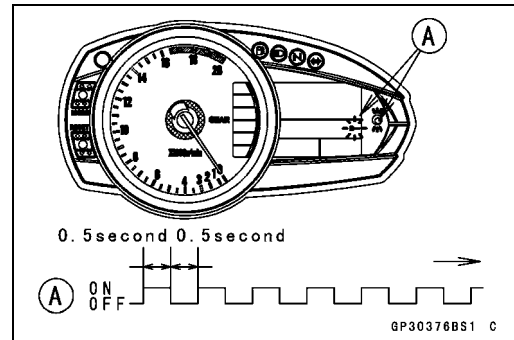

- Insert the user key 1 to the ignition switch and turn it ON.

### NOTE

- Keep the other user keys away from the immobilizer antenna.
- If there is any problem in the registration, the warning indicator light (LED) [A] blinks to display the collation error. Immobilizer Amplifier Failure

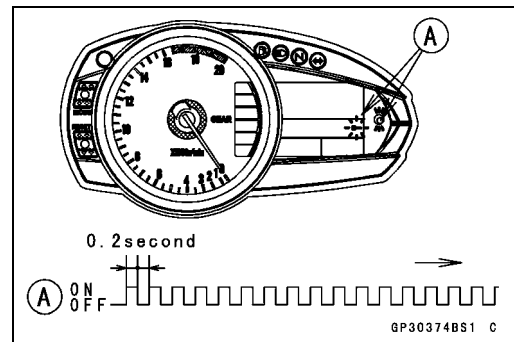

When Registered User Key is Inserted.

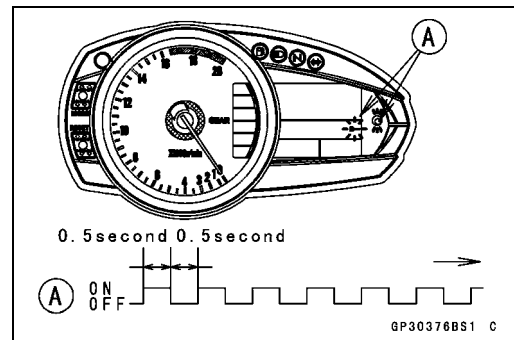

## Immobilizer System (Equipped Models)

### User Key Collation Error

- The user key 1 is registered in the ECU.
- The warning indicator light (LED) [A] blinks 2 times and stops for 1 second and then repeats this cycle to indicate successful registration of user key.

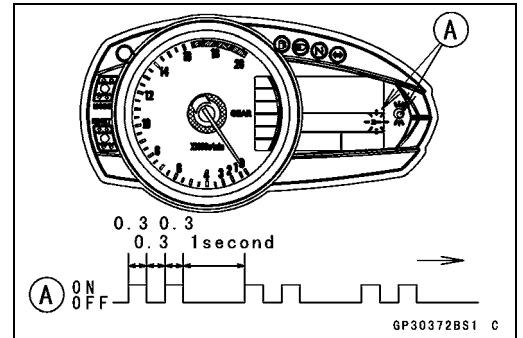
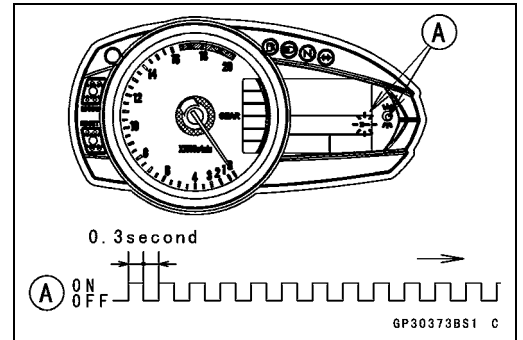

- Turn off and remove the user key 1.
- The warning indicator light (LED) [A] blinks to display the registration mode codes.

#### NOTE

- Insert next key and turn ON within 15 seconds after previous key is turned off and removed otherwise registration mode will be ended and the warning indicator light (LED) goes off.
  - To return to the registration mode start the master key verification procedure. This applies to all user key registration.
- Insert the user key 2 to the ignition switch and turn it ON.

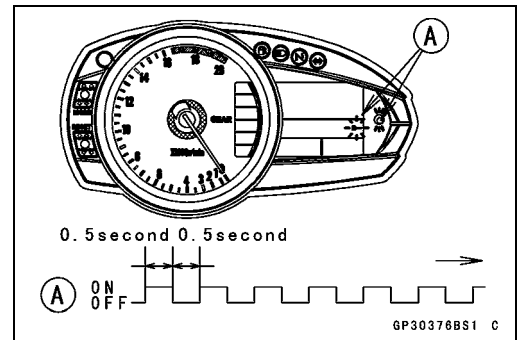

- If there is any problem in the registration, the warning indicator light (LED) [A] blinks to display the collation error code.

Immobilizer Amplifier Failure

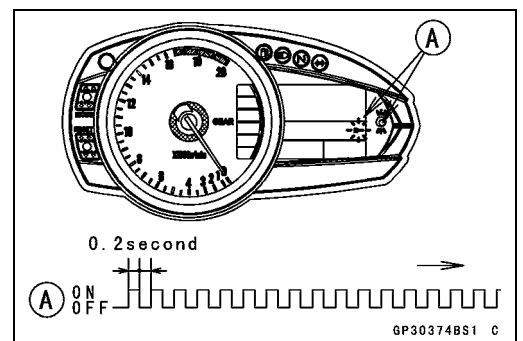

# 16-104 ELECTRICAL SYSTEM

## Immobilizer System (Equipped Models)

When Registered User Key is Inserted.

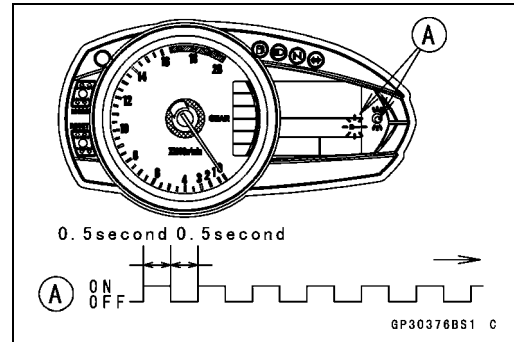

User Key Collation Error

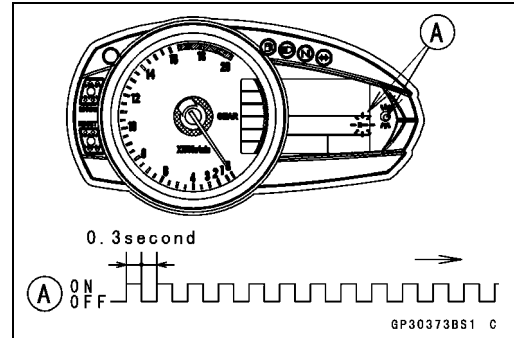

- The user key 2 is registered in the ECU.
- The warning indicator light (LED) [A] blinks 3 times and stops for 1 second and then repeats this cycle to indicate successful registration of user key 2.
- Turn OFF the ignition switch and wait for period more than 15 seconds.
- The registration mode automatically ends.

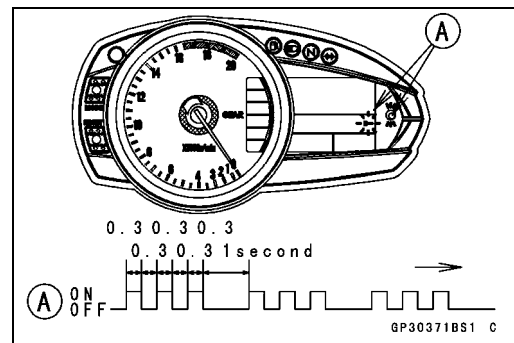

- FI indicator light goes off [A].

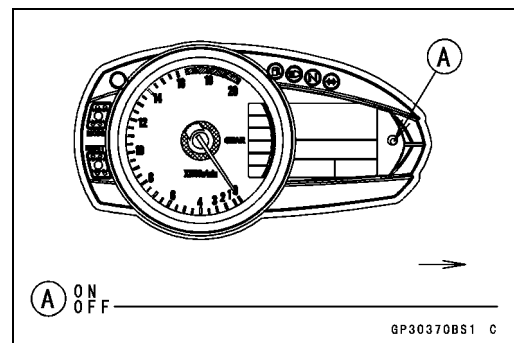

### NOTE

- Turn the ignition switch ON with the registered user key.
- Check that the engine can be started using all registered user keys.

### Case 4: When master key is faulty or lost.

The master key replacement is considered very rare case. However if it is required, the following is necessary.

### NOTE

- The ECU must be replaced with a new one because the master key code that is registered in the current ECU can not be rewritten.



## Immobilizer System (Equipped Models)

- Prepare a new ECU [A], new master key [B] and current user keys [C].

### NOTE

- *The key registration unit is not required.*
- *The key registration process is same as the electric control unit replacement.*

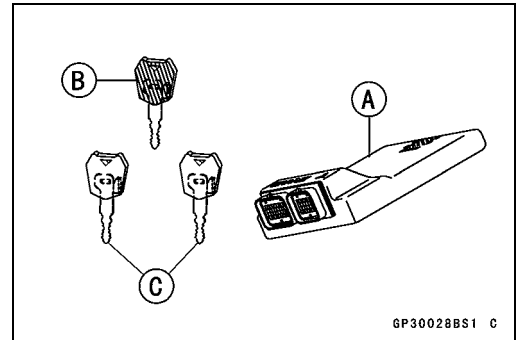

### Case 5: When replacing the antenna.

- Prepare a new antenna.
- Refer to the Immobilizer System Parts Replacement in this chapter.

### NOTE

- *No key registration is required.*

# 16-106 ELECTRICAL SYSTEM

## Immobilizer System (Equipped Models)

### All Keys Initial Registration Flow Chart

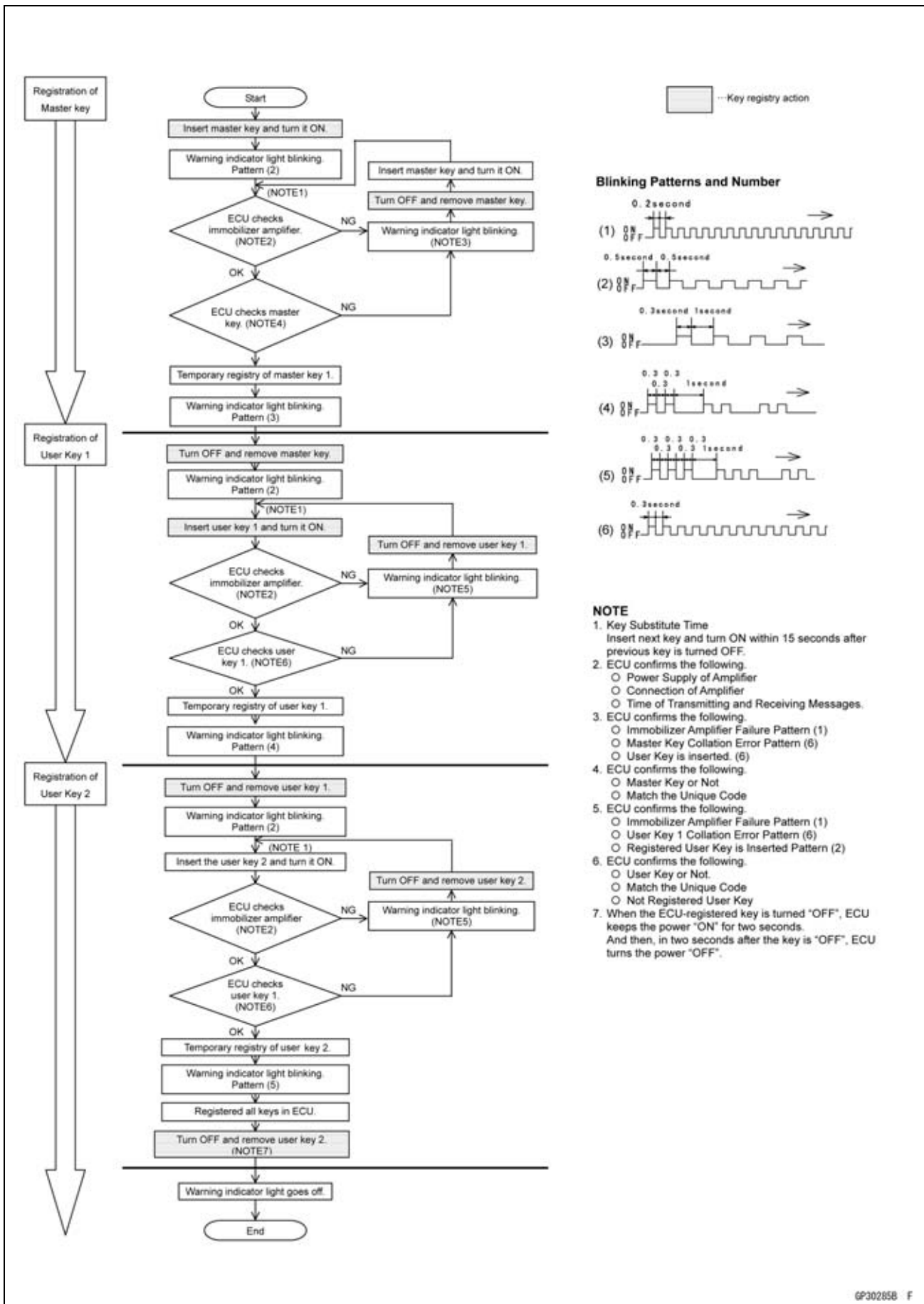

## Immobilizer System (Equipped Models)

### Immobilizer System Parts Replacement

#### Immobilizer Antenna

- Remove:
  - Left Inner Cover (see Inner Cover Removal in the Frame chapter)
- Disconnect the lead connectors [A] and clamp [B].

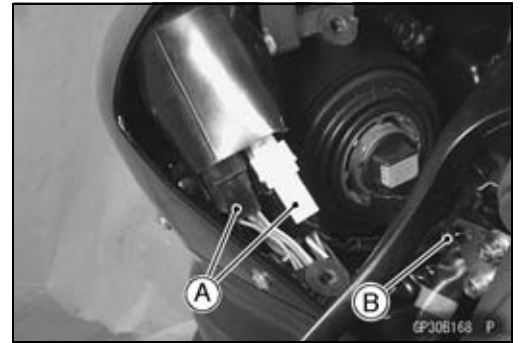

- Remove:
  - Clutch Cable Upper End
  - Throttle Cable Upper Ends
  - Steering Stem Head and Handlebar (see Handlebar Removal in the Steering chapter)
- Using a small chisel or punch [A], turn out the Torx bolts.



- Cut the band [A] and tape [B].
- Remove the screws [C].
- Remove the antenna [D] with the cover [E].

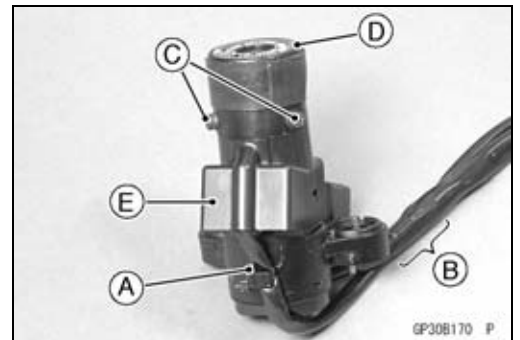

- Pull the lower parts [A] of the cover outside to clear the projections [B] of the ignition switch.

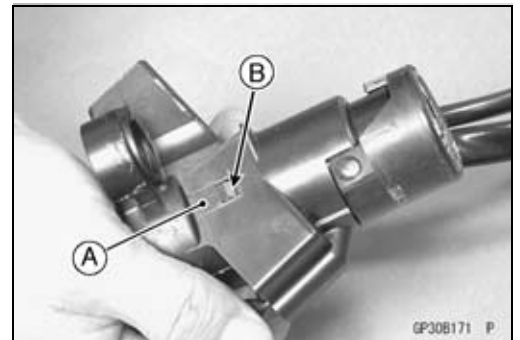

- Install the rubber damper [A] around the top portion of the switch [B].
- Put the grooves on the projections.

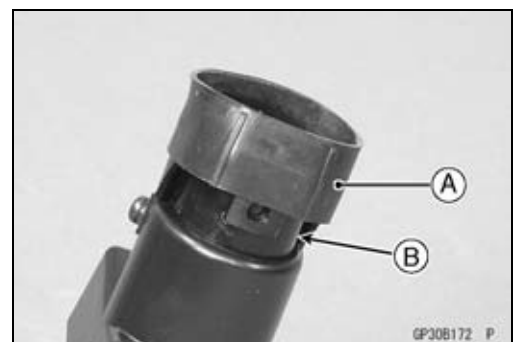

## 16-108 ELECTRICAL SYSTEM

### Immobilizer System (Equipped Models)

- Install the clamp [A].
- Tighten a new Torx bolt [B] until the bolt head [C] is broken.
- Run the leads correctly (see Cable, Wire, and Hose Routing section in the Appendix chapter).

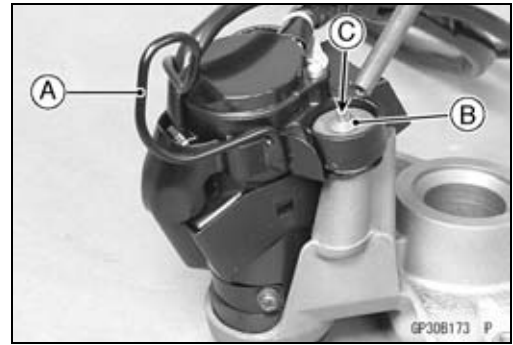

### Immobilizer Amplifier Replacement

- Remove:
  - Windshield (see Windshield Removal in the Frame chapter)
- Pull out the amplifier [A].

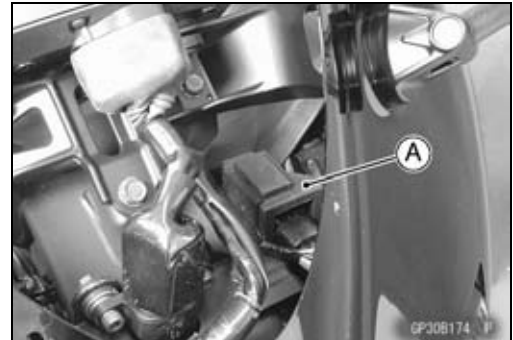

- Disconnect the connector [A].
- Pull the amplifier [B] backward to clear the hooks.

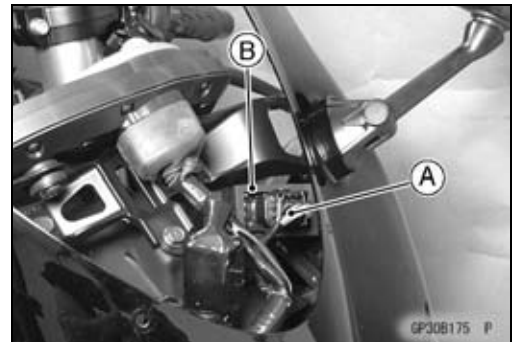

### ECU (Electric Control Unit) Replacement (for Equipped Models)

- Refer to the ECU Removal in the Fuel System (DFI) chapter (ECU Removal in the Fuel System (DFI) chapter).

## Immobilizer System (Equipped Models)

### Immobilizer Relational Parts Replacement Chart

		Failed or Lost Part					
		Master Key (Red)	User Key (Black)	Ignition Switch	Antenna	Amplifier	ECU
*	Master Key (Red)	●					
	User Key (Black)		●	○			
	Ignition Switch			●			
	Antenna				●		
	Amplifier					●	
	ECU	○					●
*	Replacement Part						
●	Main Replacement Part						
○	Additional Replacement Part						

### **Immobilizer System Inspection**

- Refer to the Immobilizer Amplifier and Blank Key Detection section in the Fuel System (DFI) chapter.

# 16-110 ELECTRICAL SYSTEM

## Immobilizer System (Equipped Models)

### Immobilizer System Circuit

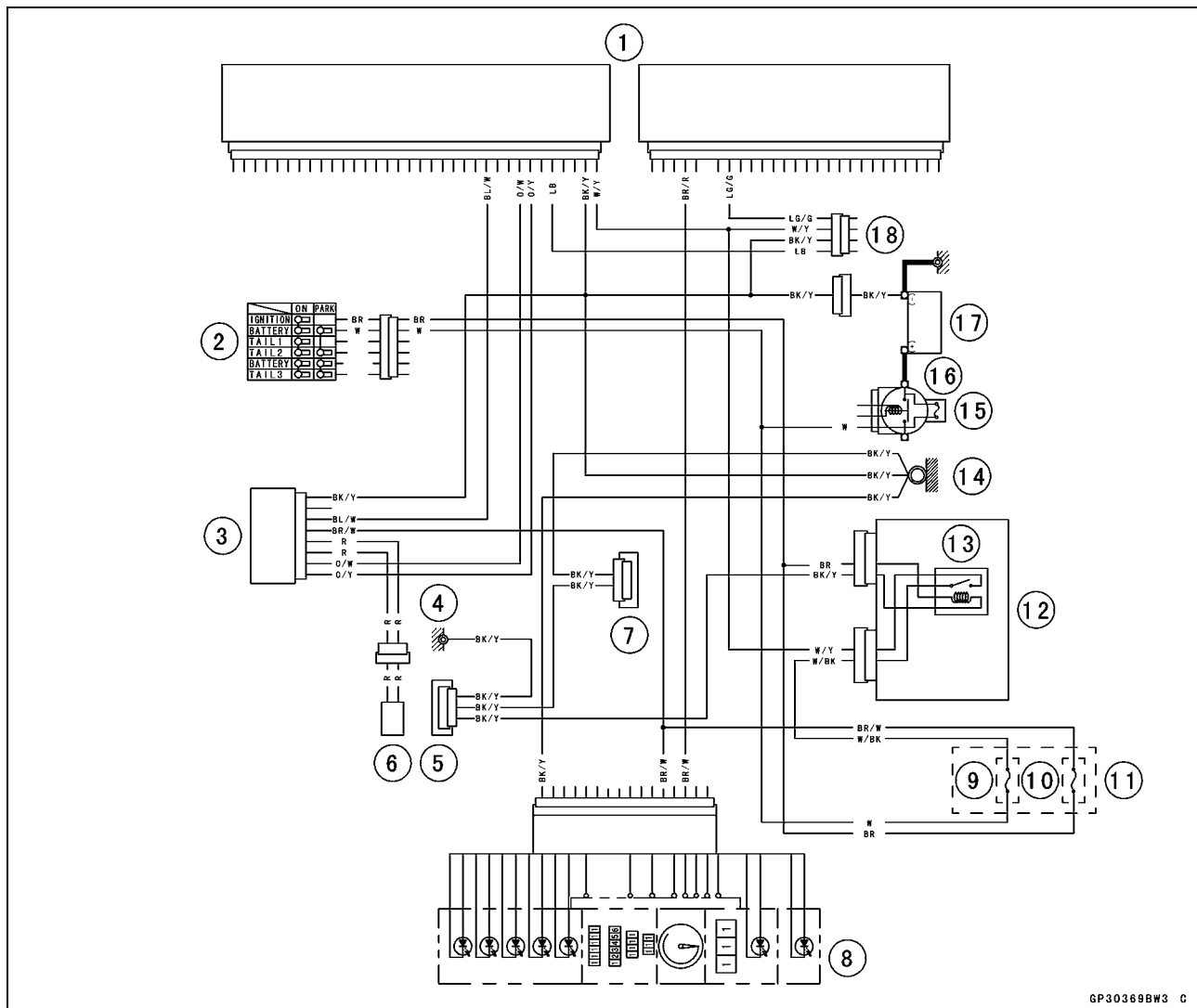

GP30369BW3 C

1. ECU
2. Ignition Switch
3. Immobilizer Amplifier
4. Cylinder Head Cover Ground
5. Joint Connector C
6. Immobilizer Antenna
7. Joint Connector B
8. Meter Unit
9. ECU Fuse 10 A
10. Ignition Fuse 10 A
11. Fuse Box
12. Relay Box
13. ECU Main Relay
14. Frame Ground
15. Main Fuse 30 A
16. Starter Relay
17. Battery 12 V 8 Ah
18. Immobilizer/Kawasaki Self-diagnostic System Connector

## Switches and Sensors

### **Brake Light Timing Inspection**

- Refer to the Brake Light Switch Operation Inspection in the Periodic Maintenance chapter (see Brake Light Switch Operation Inspection in the Periodic Maintenance chapter).

### **Brake Light Timing Adjustment**

- Refer to the Brake Light Switch Operation Inspection in the Periodic Maintenance chapter (see Brake Light Switch Operation Inspection in the Periodic Maintenance chapter).

### **Gear Position Switch Removal**

- Set up the fuel tank (see Speed Sensor Removal).
- Disconnect:
  - Gear Position Switch Lead Connector [A]
  - Clamp [B]

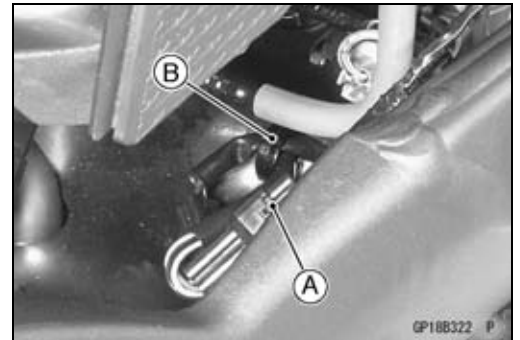

- Open the clamps [A].

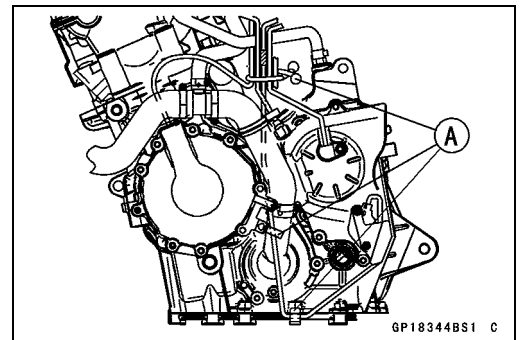

- Remove:
  - Engine Sprocket Cover [A] (see Engine Sprocket Removal in the Final Drive chapter)
  - Speed Sensor (see Speed Sensor Removal) [B]
- Disconnect the side stand switch lead connector [C].

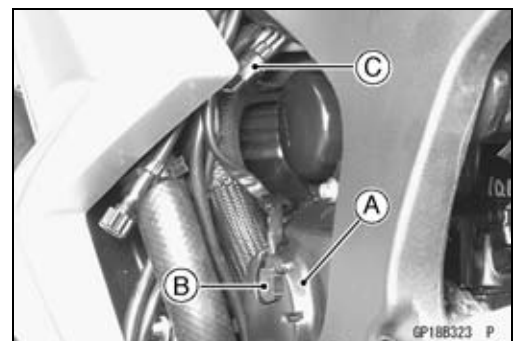

- Remove:
  - Screws [A]
  - Holding Plate [B]
  - Gear Position Switch

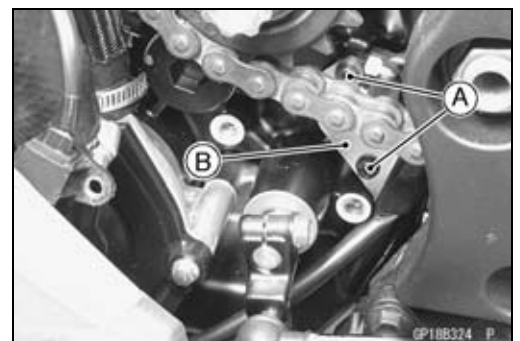

## 16-112 ELECTRICAL SYSTEM

### Switches and Sensors

- Remove the pins [A] and springs from the shift drum.

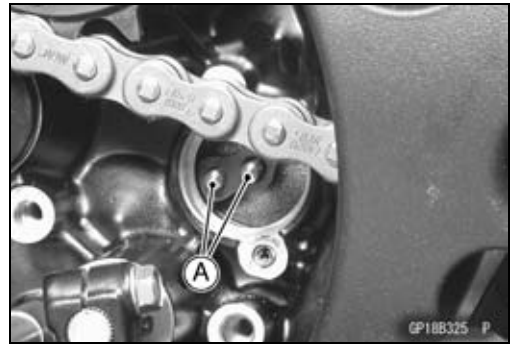

#### ***Gear Position Switch Installation***

- Securely place the springs [A] and pins [B] into the holes [C] of the shift drum.

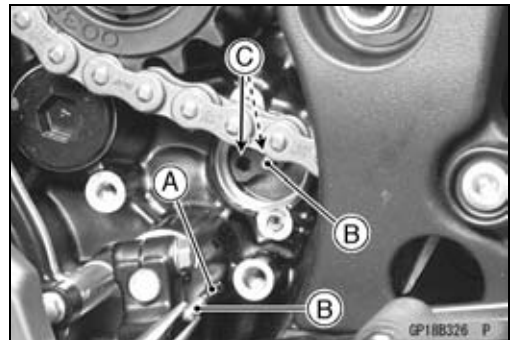

- Apply grease to the new O-ring [A].
- Install:  
Gear Position Switch [B]

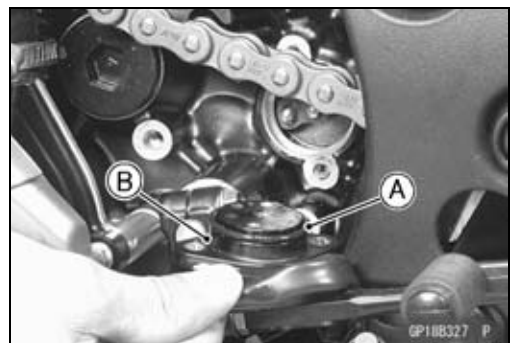

- Install:  
Holding Plate [A]



- Apply a non-permanent locking agent to the gear position switch screws.
- Tighten:  
**Torque - Gear Position Switch Screws: 2.9 N·m (0.30 kgf·m, 26 in·lb)**
- Run the gear position switch and side stand switch lead correctly (see Cable, Wire, and Hose Routing section in the Appendix chapter).
- Install the removed parts (see appropriate chapters).



Switches and Sensors

**Gear Position Switch Inspection**

**NOTE**

○ Be sure the transmission mechanism is good condition.

- Disconnect the connector [A].  
Clamp [B]

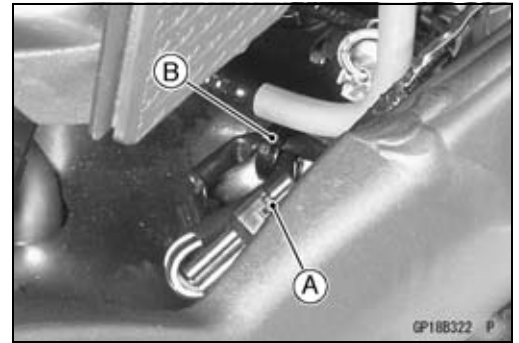

- Set the hand tester [A] to the 1 kΩ or × 100 Ω range and connect it to the terminals in the oil pressure switch/gear position switch lead connector [B] and ground.

- [C] Internal Circuit
- [1] Light Green Lead
- [2] Green/Red Lead
- [3] Black Lead

**Special Tool - Hand Tester: 57001-1394**

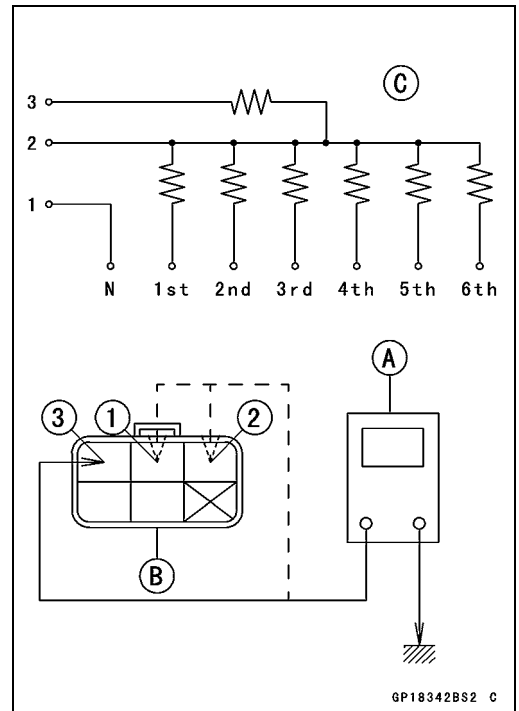

**Gear Position Switch Resistance**

**kΩ**

Gear Position	Connections		
	[1]-Ground	[2]-Ground	[3]-Ground
Neutral	about 0	—	—
1st	—	3.00 ~ 3.32	11.63 ~ 12.87
2nd	—	1.70 ~ 1.89	10.33 ~ 11.44
3rd	—	1.07 ~ 1.19	9.70 ~ 10.74
4th	—	0.695 ~ 0.769	9.32 ~ 10.32
5th	—	0.430 ~ 0.476	9.06 ~ 10.03
6th	—	0.248 ~ 0.274	8.89 ~ 9.81

★ If the tester reading is not as specified, replace the gear position switch with a new one.

# 16-114 ELECTRICAL SYSTEM

## Switches and Sensors

### Switch Inspection

- Using a hand tester, check to see that only the connections shown in the table have continuity (about zero ohms).
- For the switch housings and the ignition switch, refer to the tables in the Wiring Diagram.
- ★ If the switch has an open or short, repair it or replace it with a new one.

**Special Tool - Hand Tester: 57001-1394**

### Rear Brake Light Switch Connections

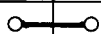
	BR	BL
When brake pedal is pushed down		
When brake pedal is released		

### Side Stand Switch Connections

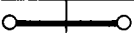
	G	BK
When side stand is up		
When side stand is down		

### Oil Pressure Switch Connections\*

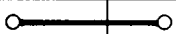
	SW. Terminal	
When engine is stopped		
When engine is running		

\*: Engine lubrication system is in good condition

## Switches and Sensors

### Water Temperature Sensor Inspection

- Remove the water temperature sensor (see Water Temperature Sensor Removal in the Fuel System (DFI) chapter).
- Suspend the sensor [A] in a container of coolant so that the temperature-sensing projection [E] and threaded portion [E] are submerged.
- Suspend an accurate thermometer [B] in the coolant.

#### NOTE

- The sensor and thermometer must not touch the container side or bottom.
- Place the container over a source of heat and gradually raise the temperature of the coolant while stirring the coolant gently.
- Using the hand tester, measure the internal resistance of the sensor.
- The sensor sends electric signals to the ECU (Electronic Control Unit) and water temperature meter in the meter unit.
- Measure the resistance across the terminals and the body (for the gauge) at the temperatures shown in the table.
- ★ If the hand tester does not show the specified values, replace the sensor.

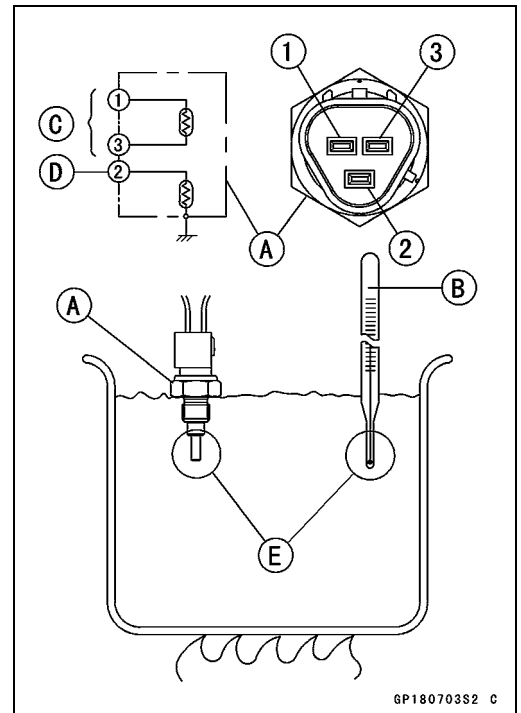

### Water Temperature Sensor

Resistance for ECU [C]	
Temperature	Resistance (kΩ) (Terminal [1]-[3])
20°C (68°F)	2.46 +0.115 -0.143
80°C (176°F)	0.32 ±0.011
110°C (230°F)	0.1426 ±0.0041

Resistance for Water Temperature Gauge [D]	
Temperature	Resistance (Ω) (Terminal [2]-Body)
50°C (122°F)	210 ±40
120°C (248°F)	21.2 ±1.5

### Speed Sensor Removal

- Remove the front side bolts of the fuel tank.
- Set up the fuel tank [A] using the suitable tool or bar [B].
- The steering position is straight.

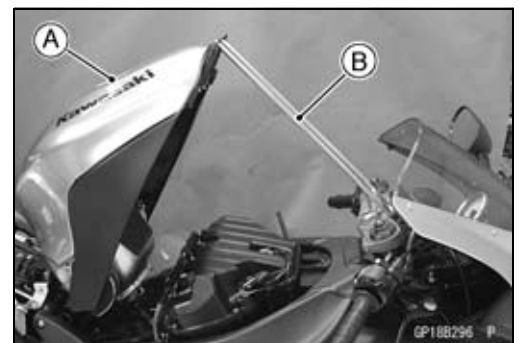

## 16-116 ELECTRICAL SYSTEM

### Switches and Sensors

- Disconnect the speed sensor lead connector [A].

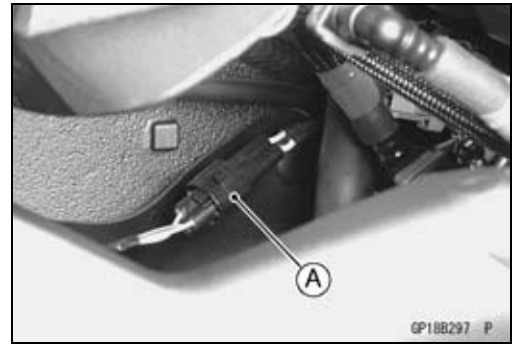

- Remove the speed sensor bolt [A].
- Open the clamps [B].
- Remove the speed sensor [C].

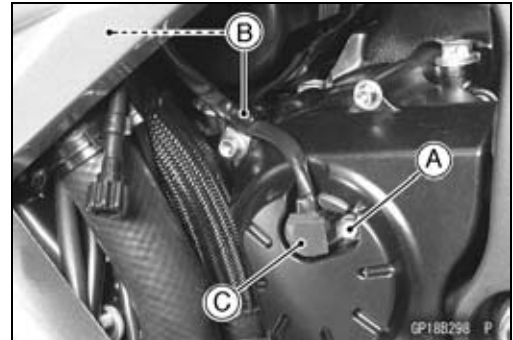

#### **Speed Sensor Installation**

- Install the speed sensor.
- Apply a non-permanent locking agent to the bolt.  
**Torque - Speed Sensor Bolt: 3.9 N·m (0.40 kgf·m, 35 in·lb)**

#### **Speed Sensor Inspection**

- Remove:  
Speed Sensor (see Speed Sensor Removal)
- Connect the speed sensor connector [A] with the battery [B], 10 kΩ resistor [C] and hand tester [D] as shown.
- Set the tester to the DC 25 V range.

**Special Tool - Hand Tester: 57001-1394**

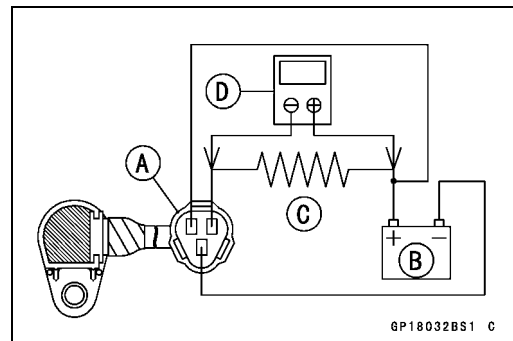

- Trace [A] each side of the speed sensor surface with the screw driver.
- Then the tester indicator should flick [B].
- ★ If the tester indicator does not flick, replace the speed sensor.

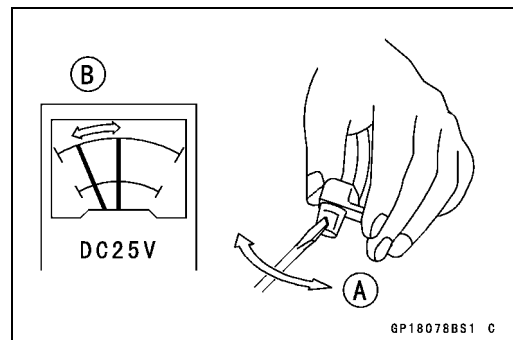

## Switches and Sensors

### Fuel Reserve Switch Inspection

- Remove:
  - Left Side Cover (see Side Cover Removal in the Frame chapter)
  - Fuel Pump Lead Connector [A]

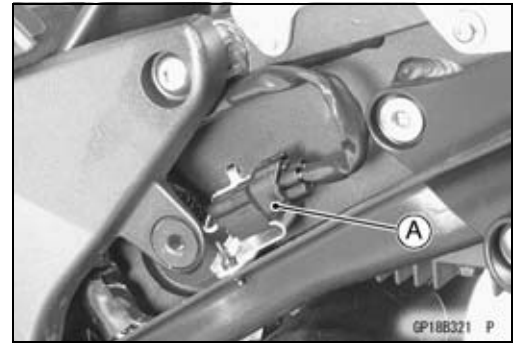

- Fill the fuel tank with fuel.
- Close the fuel tank cap surely.
- Connect the test light [A] (12 V 3.4 W bulb in a socket with leads) and the 12 V battery [B] to the fuel pump connector [C].

#### Connections

Battery (+) → 12 V 3.4 W Bulb (one side)

12 V 3.4 W Bulb (other side) → R/BK Lead Terminal

Battery (-) → BK/W Lead Terminal

- ★ If the test light turn on, the reserve switch is defective. Replace the fuel pump.

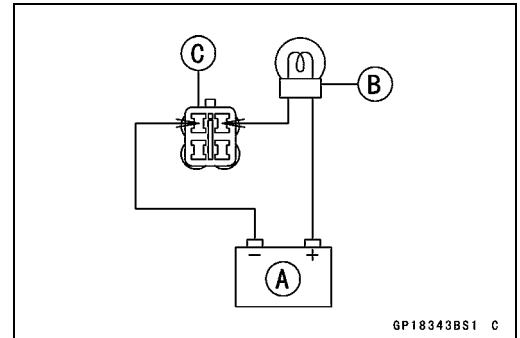

- Remove:
  - Fuel Tank (see Fuel Tank Removal in the Fuel System (DFI) chapter).
  - Fuel Pump (see Fuel Pump Removal in the Fuel System (DFI) chapter)
- Connect the test light (12 V 3.4 W bulb in a socket with leads) and the 12 V battery to the fuel pump connector as shown.
  - 12 V Battery [A]
  - Test Light [B]
  - Fuel Pump Connector [C]
  - Fuel Reserve Switch [D]

- ★ If the test light doesn't light, replace the fuel pump.

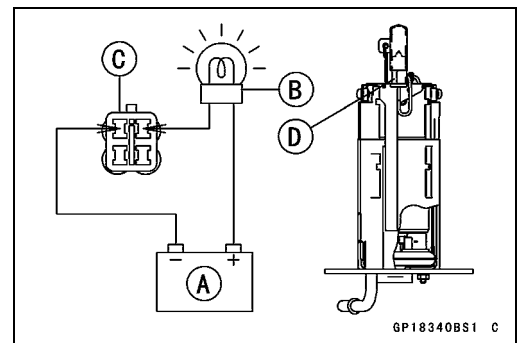

#### NOTE

○ It may take a long time to turn on the test light in case that the fuel reserve switch is inspected just after the fuel pump is removed. Leave the fuel reserve switch with leads for inspection connected for few minutes.

### Oxygen Sensor Removal (Equipped Models)

- Remove:
  - Right Middle Fairing (see Middle Fairing Removal in the Frame chapter)
- Disconnect the oxygen sensor lead connectors [A].
- Remove the oxygen sensors [B].

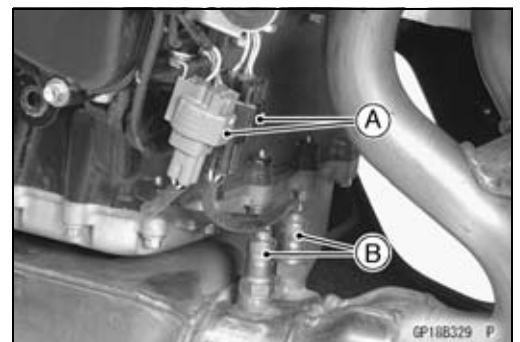

## 16-118 ELECTRICAL SYSTEM

### Switches and Sensors

#### Oxygen Sensor Installation (Equipped Models)

##### CAUTION

Never drop the oxygen sensor [A], especially on a hard surface. Such a shock to the unit can damage it. Do not touch the sensing part [B] to prevent oil contact. Oil contamination from hands can reduce sensor performance.

- Install:
  - Left Side Oxygen Sensor [A] (Connector Color, Black)
  - Right Side Oxygen Sensor [B] (Connector Color, Gray)

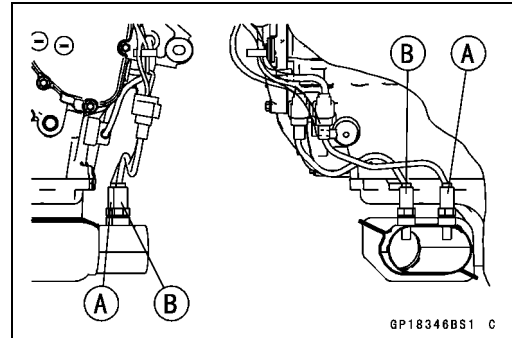
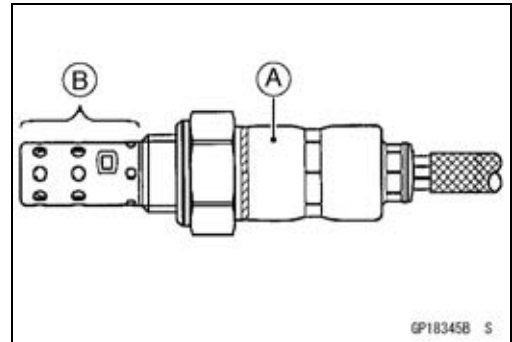

- Tighten:
  - Torque - Oxygen Sensor: 25 N·m (2.5 kgf·m, 18 ft·lb)**
- Run the oxygen sensor lead correctly (see Cable, Wire, and Hose Routing section in the Appendix chapter).

#### Oxygen Sensor Inspection (Equipped Models)

- Refer to the Oxygen Sensor Inspection in the Fuel System (DFI) chapter (Oxygen Sensor Inspection in the Fuel System (DFI) chapter).

## Relay Box

The relay box [A] has relays and diodes. The relays and diodes can not be removed.

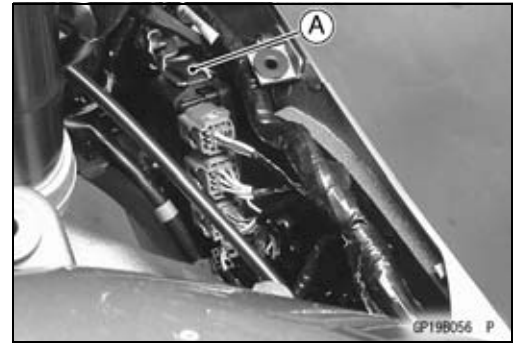

### Relay Box Removal

- Remove:
  - Right Inner Cover (see Inner Cover Removal in the Frame chapter)
  - Fuse Box [A] (see Fuse Box Removal)



- Disconnect the connectors [B] and take out the relay box [A] .

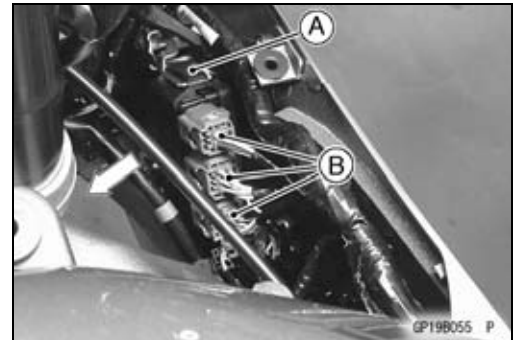

### Relay Circuit Inspection

- Remove the relay box (see Relay Box Removal).
- Check conductivity of the following numbered terminals by connecting the hand tester and one 12 V battery to the relay box as shown.
- ★ If the tester does not read as specified, replace the relay box.

# 16-120 ELECTRICAL SYSTEM

## Relay Box

### Relay Circuit Inspection (with the battery disconnected)

	Tester Connection	Tester Reading ( $\Omega$ )
Headlight Relay	1-3	$\infty$
ECU Main Relay	6-7	$\infty$
	4-5	Not $\infty^*$
Fuel Pump Relay	7-8	$\infty$
	9-10	Not $\infty^*$
Starter Circuit Relay	11-16	$\infty$
	11-12	$\infty$
Fan Relay	17-20	$\infty$
	18-19	Not $\infty^*$

### Relay Circuit Inspection (with the battery connected)

	Battery Connection (+) (-)	Tester Connection	Tester Reading ( $\Omega$ )
ECU Main Relay	2-11	1-3	0
	4-5	7-6	0
Fuel Pump Relay	9-10	7-8	0
Fan Relay	18-19	17-20	0

	Battery Connection (+) (-)	Tester Connection DC 25 V Range	Tester Reading (V)
Starter Circuit Relay	16-12	11-12	Battery Voltage

### Diode Circuit Inspection

- Remove the relay box (see Relay Box Removal).
- Check conductivity of the following pairs of terminals (see Relay Box Internal Circuit).

### Diode Circuit Inspection

Tester Connection	1-11, 2-11, 12-13, 12-15, 12-16, 13-14, 13-15
-------------------	---

★ The resistance should be low in one direction and more than ten times as much in the other direction. If any diode shows low or high in both directions, the diode is defective and the relay box must be replaced.

### NOTE

○ The actual meter reading varies with the meter or tester used and the individual diodes, but generally speaking, the lower reading should be from zero to one half the scale.





## 16-122 ELECTRICAL SYSTEM

### Fuse

#### 30 A Main Fuse Removal

- Remove:
  - Front Seat (see Front Seat Removal in the Frame chapter)
- Pull out the starter relay.

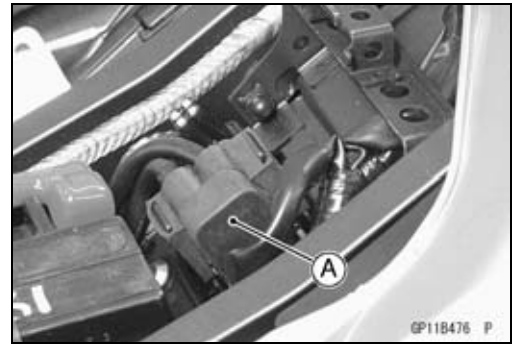

- Remove:
  - 30 A Main Fuse Connector [A]
- Pull out the main fuse [B] from the starter relay with needle nose pliers.

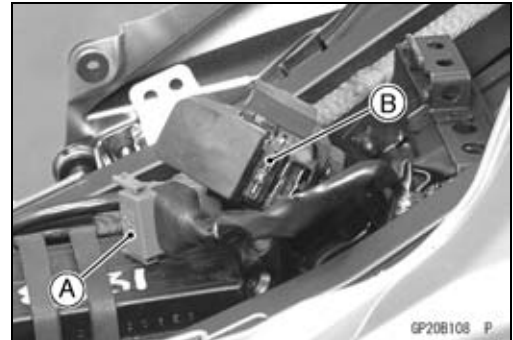

#### Fuse Box Fuse Removal

- Remove the right upper inner cover (see Inner Cover Removal in the Frame chapter).
- Push the hook [A] to lift up the lid [B].

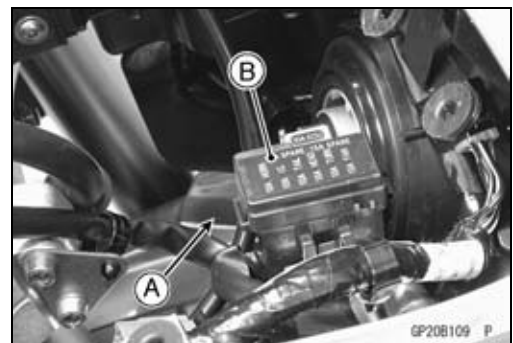

- Pull the fuses [A] straight out of the fuse box with needle nose pliers.

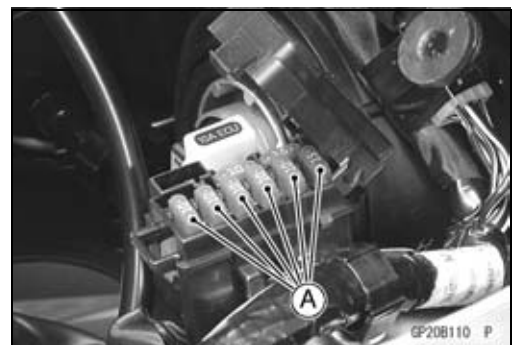

#### 10 A ECU Fuse Removal

- Remove:
  - Right Upper Inner Cover (see Rear Seat Removal in the Frame chapter)
- Pull the hook [A] to lift up the lid [B]

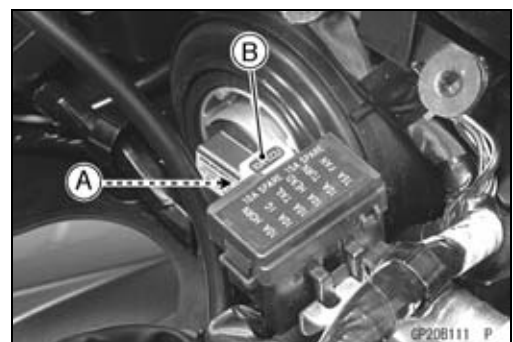





# Appendix

## Table of Contents

Cable, Wire, and Hose Routing.....	17-2
Troubleshooting Guide .....	17-30

## 17-2 APPENDIX

### Cable, Wire, and Hose Routing

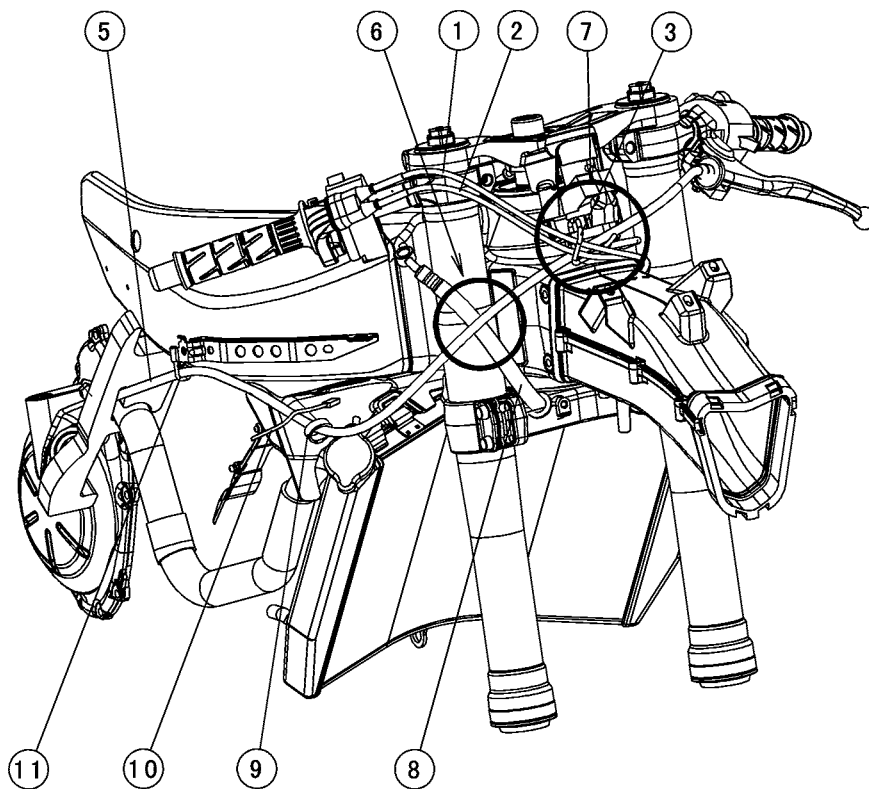
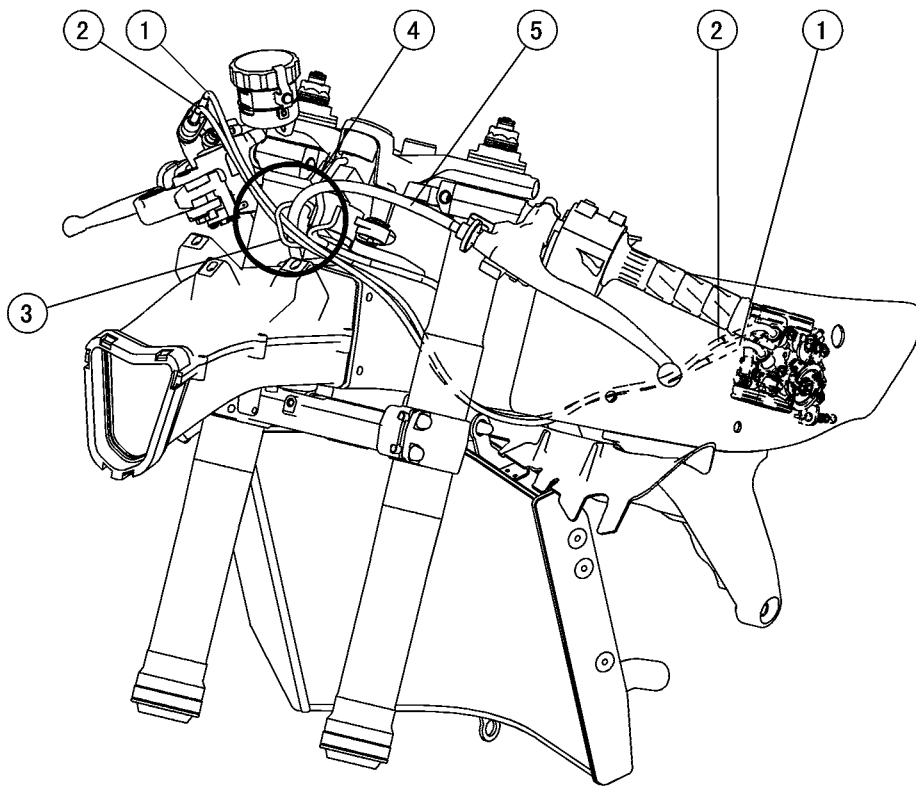

---

**Cable, Wire, and Hose Routing**

---

1. Throttle Cable (Accelerator)
2. Throttle Cable (Decelerator)
3. Clamp
4. Run the clutch cable through backside of the throttle cables.
5. Clutch Cable
6. Run the clutch cable through front side of the front fork and brake hose.
7. Run the throttle cables through front side of the clutch cable.
8. Front Brake Hose
9. Install the clamp to the heat insulation plate so that the direction of the claw faces outside of the frame.
10. Fan Motor Lead
11. Clamp (Run the clutch cable through the clamp.)

# 17-4 APPENDIX

## Cable, Wire, and Hose Routing

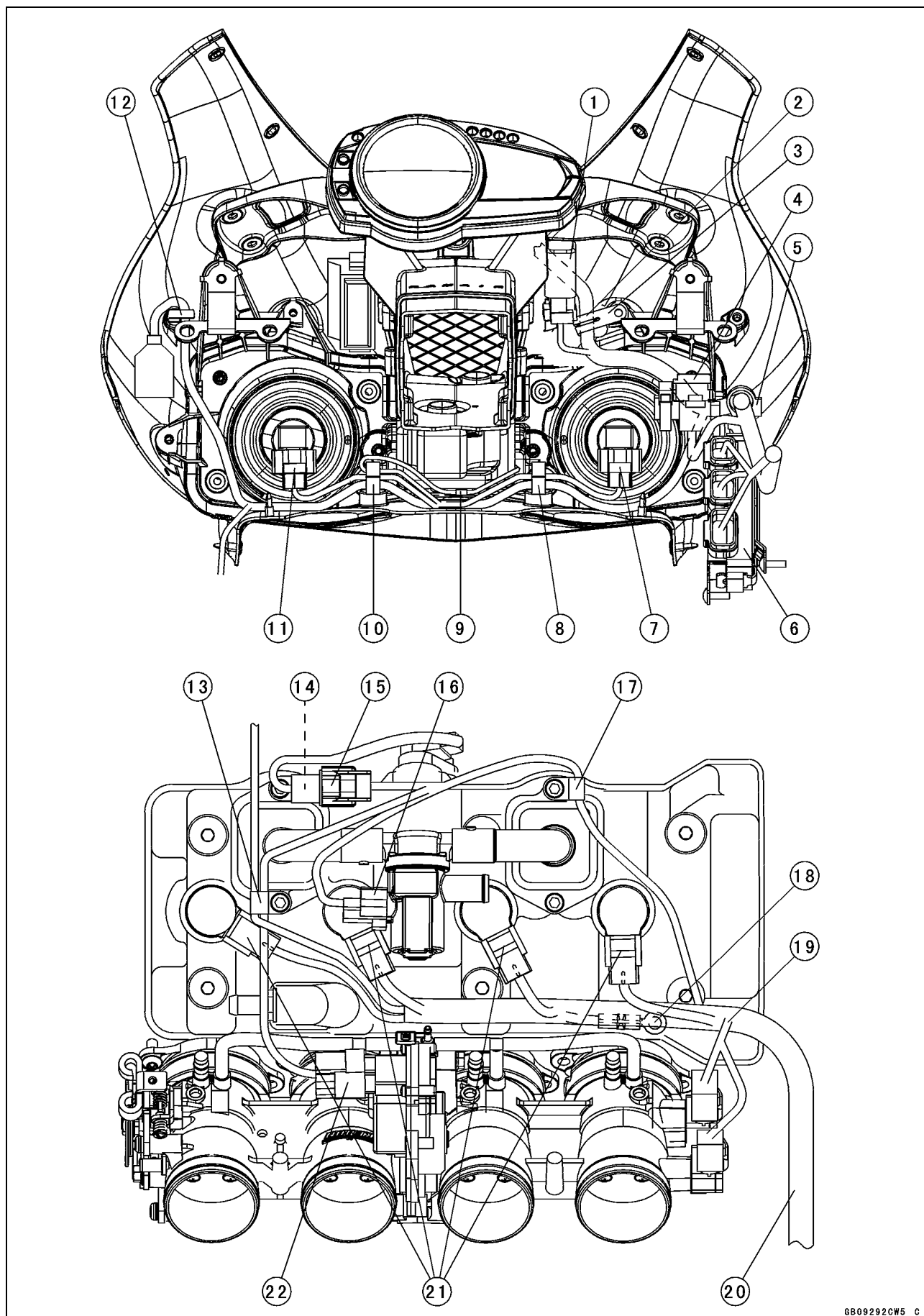



---

**Cable, Wire, and Hose Routing**

---

1. Turn Signal Relay
2. Clamp the harness so that they does not touch the turn signal relay.
3. Clamp
4. Fuse Box
5. Clamp
6. Replay Box Clamp
7. Low Beam Headlight Connector
8. Clamp the low beam headlight lead and main harness.
9. City Light Lead Connector
10. Clamp the high beam headlight lead, position light lead, and main harness.
11. High Beam Headlight Connector
12. Clamp the main harness.
13. Clamp the subthrottle valve actuator lead and horn lead
14. Bracket (Hold the camshaft position sensor lead connector.)
15. Camshaft Position Sensor Connector
16. Air Switching Valve Connector
17. Clamp the leads from the main harness
18. Install the ground lead on the cylinder head cover so that the terminal of it points to engine left side.
19. Throttle Position Sensor Lead (Run the sensor lead upper side of the main harness, crankshaft sensor lead and oil pressure switch lead.)
20. Main Harness
21. Install the stick coils so that the direction of each coil connector align with the marks on the cylinder head cover.
22. Subthrottle Valve Actuator Connector

## 17-6 APPENDIX

### Cable, Wire, and Hose Routing

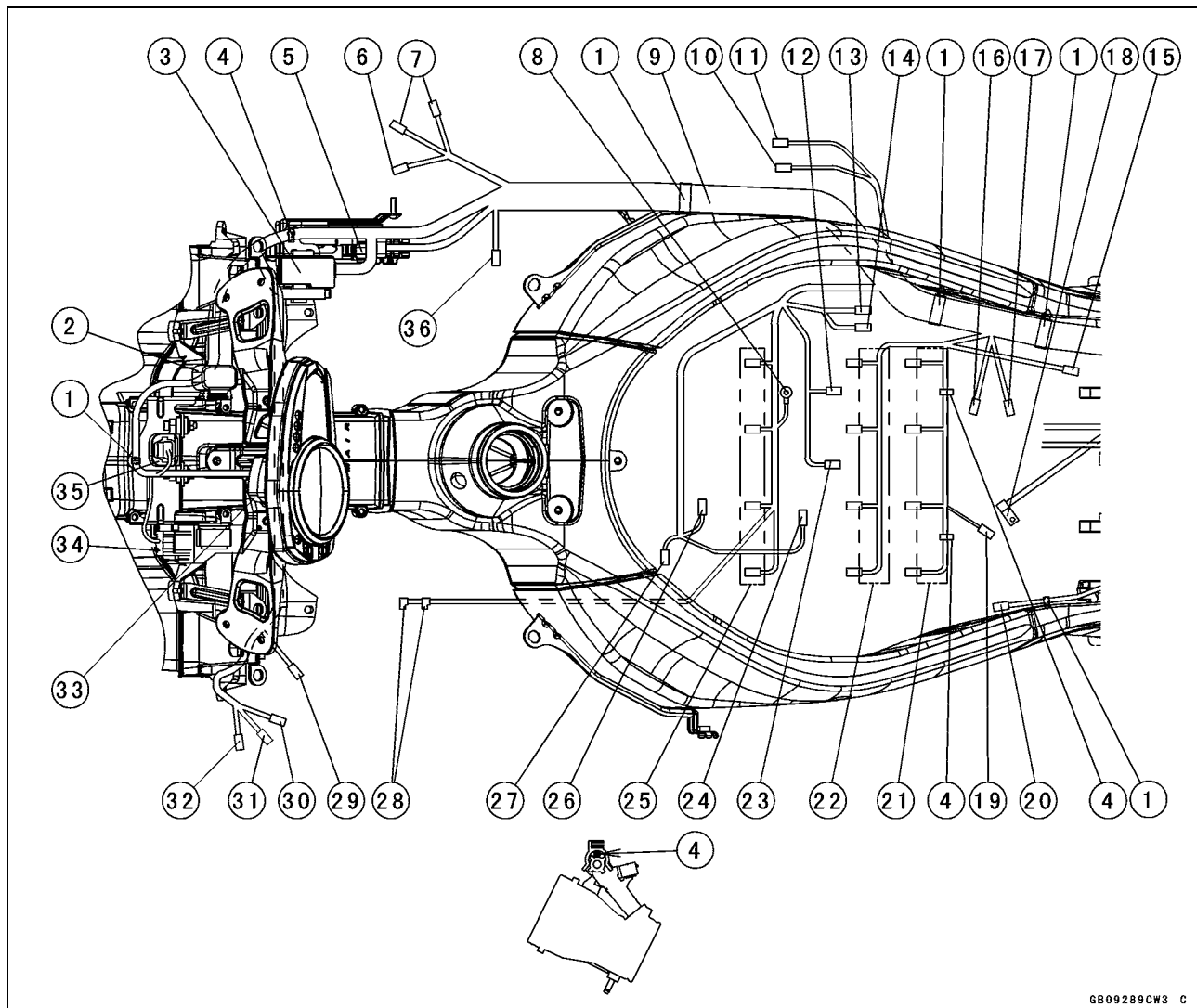

6B09289C#3 C

1. Clamps (Insertion type)
2. Turn Signal Relay
3. Fuse Box
4. Clamp
5. Relay Box
6. Front Right Turn Signal Light Lead Connector
7. Right Handlebar Switch Housing Lead Connectors
8. Engine Ground Lead Terminal
9. Main Harness
10. Oxygen Sensor (#1, #2) Lead Connector (Black)
11. Oxygen Sensor (#3, #4) Lead Connector (Gray)
12. Inlet Air Pressure Sensor Lead Connector
13. Main Throttle Sensor Lead Connector
14. Subthrottle Throttle Sensor Lead Connector
15. Rear Brake Light Switch Lead Connector
16. Crankshaft Sensor Lead Connector
17. Gear Position Switch Lead Connector
18. Battery Negative Cable Connector
19. Water Temperature Sensor Lead Connector
20. Speed Sensor Lead Connector
21. Primary Fuel Injector Lead Connectors (Left to Right #11, #21, #31, #41)
22. Secondary Fuel Injector Lead Connectors (Left to Right #12, #22, #32, #42)
23. Inlet Air Temperature Sensor Lead Connector
24. Subthrottle Valve Actuator Lead Connector
25. Stick Coil Lead Connectors (Left to Right #1, #2, #3, #4)
26. Air Switching Valve Lead Connector
27. Camshaft Position Sensor Lead Connector
28. Horn Lead Connectors
29. Front Left Turn Signal Light Lead Connector
30. Ignition Switch Lead Connector
31. Immobilizer Antenna (Equipped Models)
32. Left Handlebar Switch Housing Lead Connector
33. Meter Connector
34. Immobilizer Amplifier (Equipped Models)
35. Vehicle-down Sensor
36. Radiator Fan Motor Lead Connector

## Cable, Wire, and Hose Routing

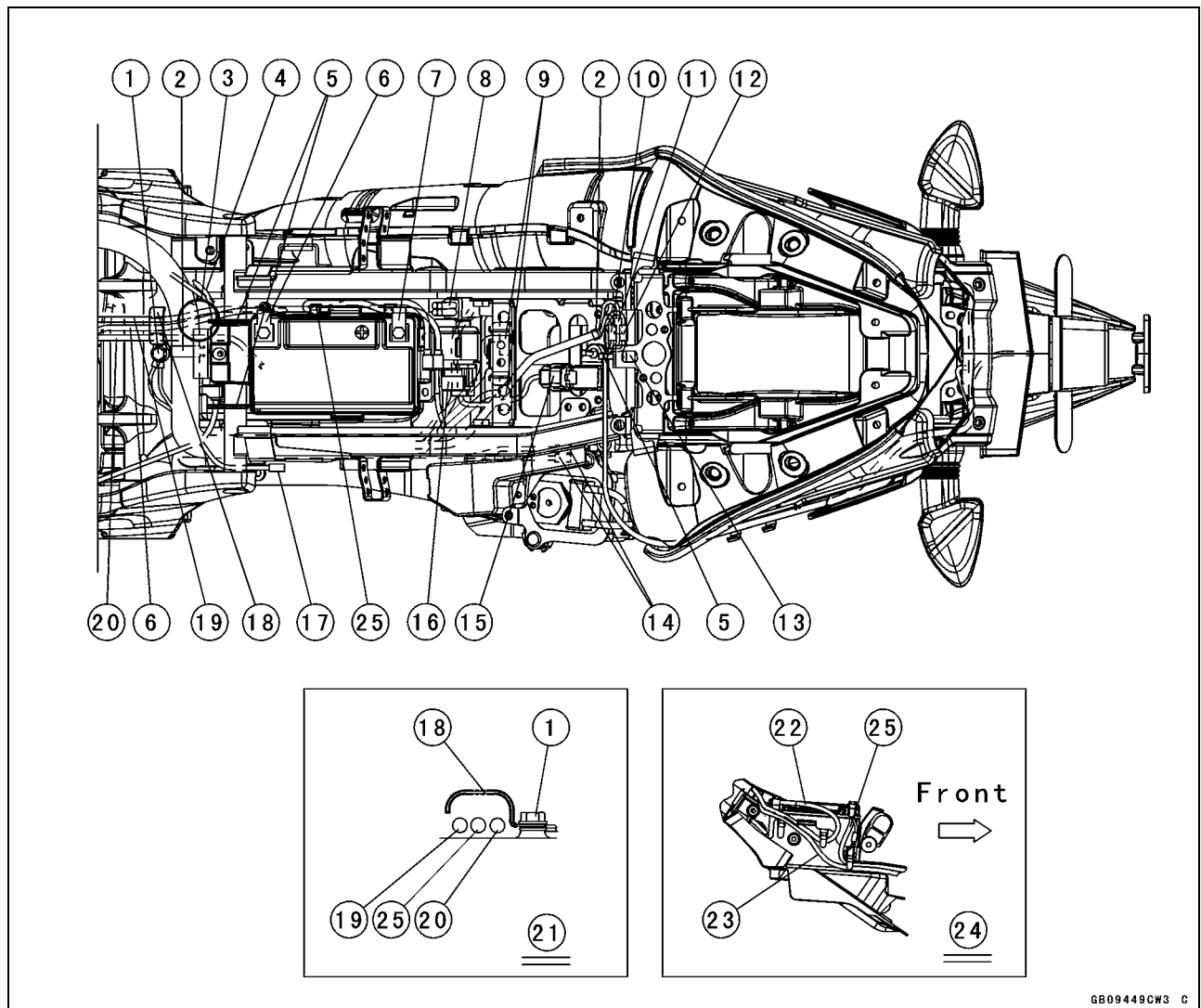

GB09449CW3 C

- |  |  |
|--|--|
| <ol style="list-style-type: none"> <li>1. Frame Ground</li> <li>2. Clamps (Insertion type)</li> <li>3. Run the alternator lead and regulator/rectifier lead through the notch of rear fender.</li> <li>4. Run the regulator/rectifier lead to under side of the main harness.</li> <li>5. Clamps</li> <li>6. Battery Negative Terminal</li> <li>7. Battery Positive Terminal</li> <li>8. Kawasaki Diagnosis System (KDS) Connector (Run the lead of it to under side of the starter relay)</li> <li>9. ECU Connectors</li> <li>10. Rear Right Turn Signal Light Lead Connector</li> <li>11. Tail/Brake Light Lead Connector</li> <li>12. Rear Left Turn Signal Light Lead Connector</li> </ol> | <ol style="list-style-type: none"> <li>13. Licence Plate Light Lead Connector</li> <li>14. Exhaust Butterfly Valve Actuator Lead Connectors</li> <li>15. Atmospheric Pressure Sensor Connector</li> <li>16. Starter Relay</li> <li>17. Fuel Pump Lead Connector (Fix on the bracket.)</li> <li>18. Clamp</li> <li>19. Starter Motor Cable</li> <li>20. Alternator Lead</li> <li>21. Viewed From Front of the Frame</li> <li>22. Battery Positive Cable</li> <li>23. Starter Motor Cable</li> <li>24. Viewed From Rightside of Battery</li> <li>25. Battery Negative Cable</li> </ol> |
|--|--|

# 17-8 APPENDIX

## Cable, Wire, and Hose Routing

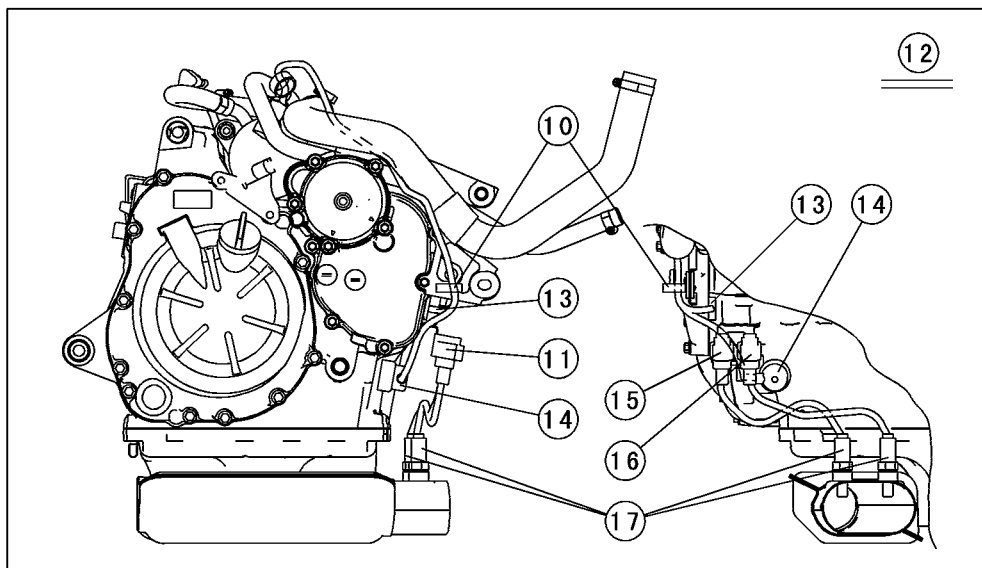
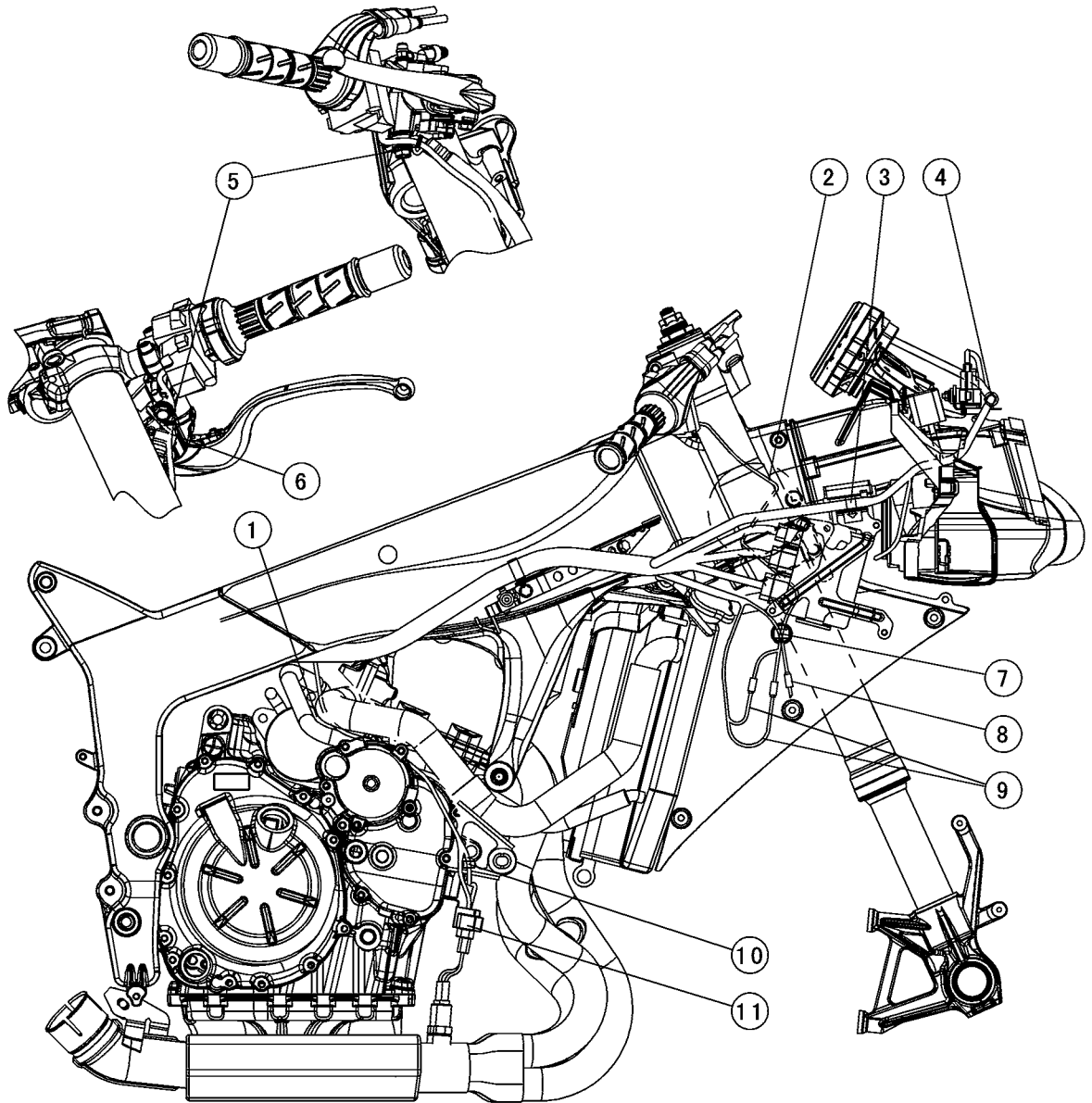

---

**Cable, Wire, and Hose Routing**

---

1. Run the oxygen sensor lead through backside of the water hose (return).
2. Run the right handlebar switch housing lead winding it from outside of right front fork to inside, and run it through upside of the steering stem.
3. Clamp
4. Clamp (Insertion Type)
5. Bands (Cut the excess portion of the band.)
6. Clamp the divergence portion of the lead and cut the excess portion of the band.
7. Clamp (Hold the front right turn signal light and right handlebar switch housing leads.)
8. Front Right Turn Signal Light Lead Connector
9. Right handlebar Switch Housing Leads (Main harness side)
10. Clamp (Clamp the oxygen sensor lead #1, #2 and oil pressure switch lead.)
11. Fix the connectors to the bracket.
12. Detail drawing of Oxygen Sensor Lead Routing (Equipped Models)
13. Crankshaft Sensor Lead
14. Install the oil pressure switch in the engine right side so that the switch lead shall be taken out to right side.
15. Oxygen Sensor #2 Connectors (Gray) (Equipped Models)
16. Oxygen Sensor #1 Connectors (Black) (Equipped Models)
17. Oxygen Sensors (Equipped Models)

# 17-10 APPENDIX

## Cable, Wire, and Hose Routing

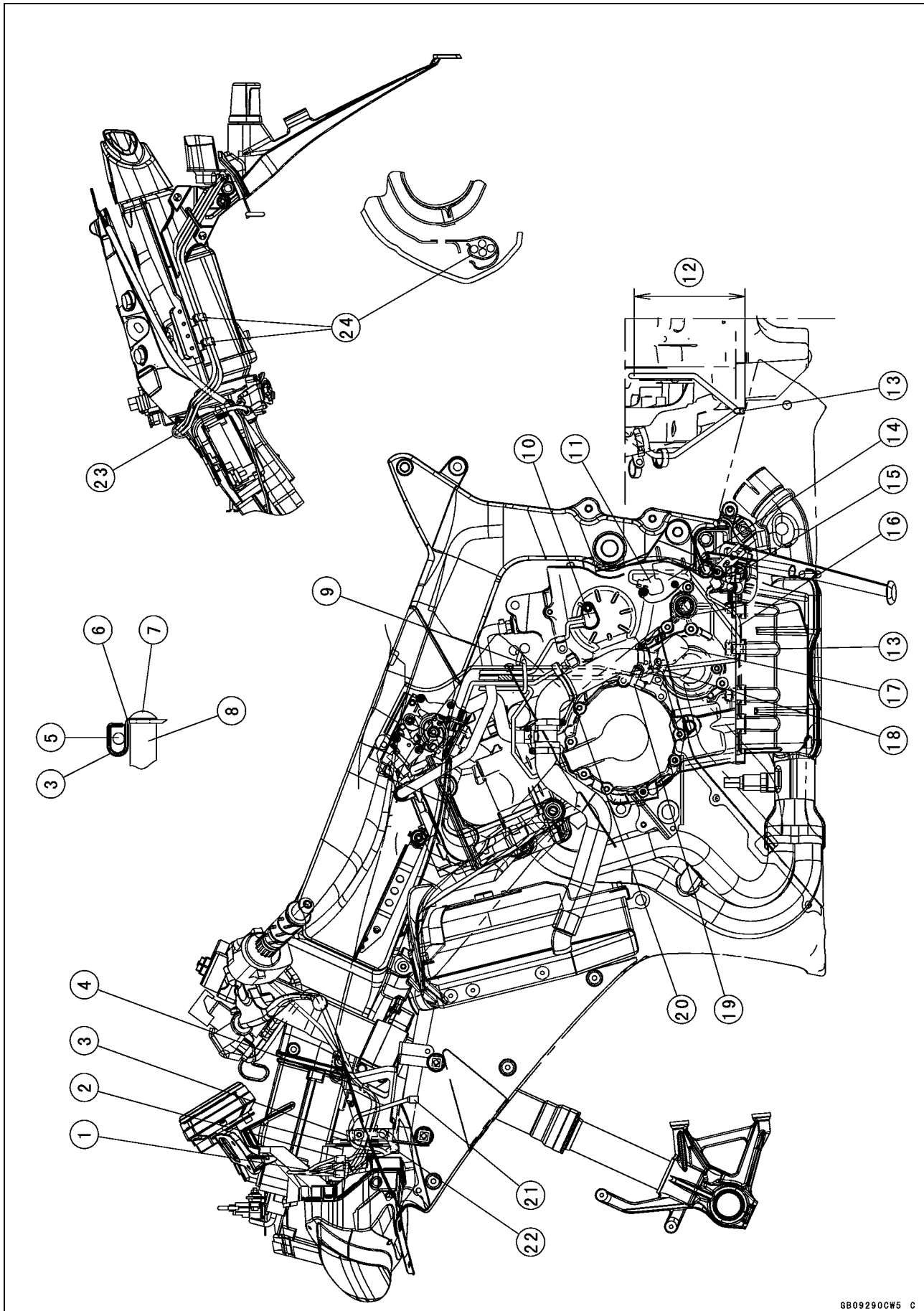

---

**Cable, Wire, and Hose Routing**

---

1. Left Handlebar Switch Housing Lead Connectors
2. Ignition Switch and Immobilizer Antenna Lead Connectors
3. Clamps
4. Clamp
5. Front Left Turn Signal Light Lead
6. Bracket (for the Canister, California Model only)
7. Screw
8. Left Middle Fairing
9. Clamp (Hold the air cleaner housing drain hose, fuel tank drain hose, idle adjusting cable, speed sensor lead, side stand switch lead, alternator lead and gear position switch lead.)
10. Speed Sensor
11. Gear Position Switch
12. Do not loose the gear position switch lead in this area because of preventing for the drive chain to contact with the lead.
13. Clamp (Hold the side stand switch and gear position switch leads.)
14. Bracket (for Gear Position Switch Mounting)
15. Side Stand Switch
16. Side Stand Switch Lead
17. Catch Tank (Position the tank to rear side of the bracket.)
18. Clamp (Install the clamp in the back side of the bracket and clamp the gear position switch and side stand switch leads.)
19. Clamp (Install the clamp in the front side of the bracket and clamp the drain hose.)
20. Clamp (Install the clamp so that smaller clamp faces to backward and hold the idle adjusting screw cable.)
21. Front Left Turn Signal Light Lead Connector
22. Push the main harness into under the headlight housing.
23. Clamp (Clamp the tail/brake Light, rear turn signal lights and licence plate light lead.)
24. Hooks (Hold the tail/brake Light, rear turn signal lights and licence plate light lead and bend the hooks.)

# 17-12 APPENDIX

## Cable, Wire, and Hose Routing

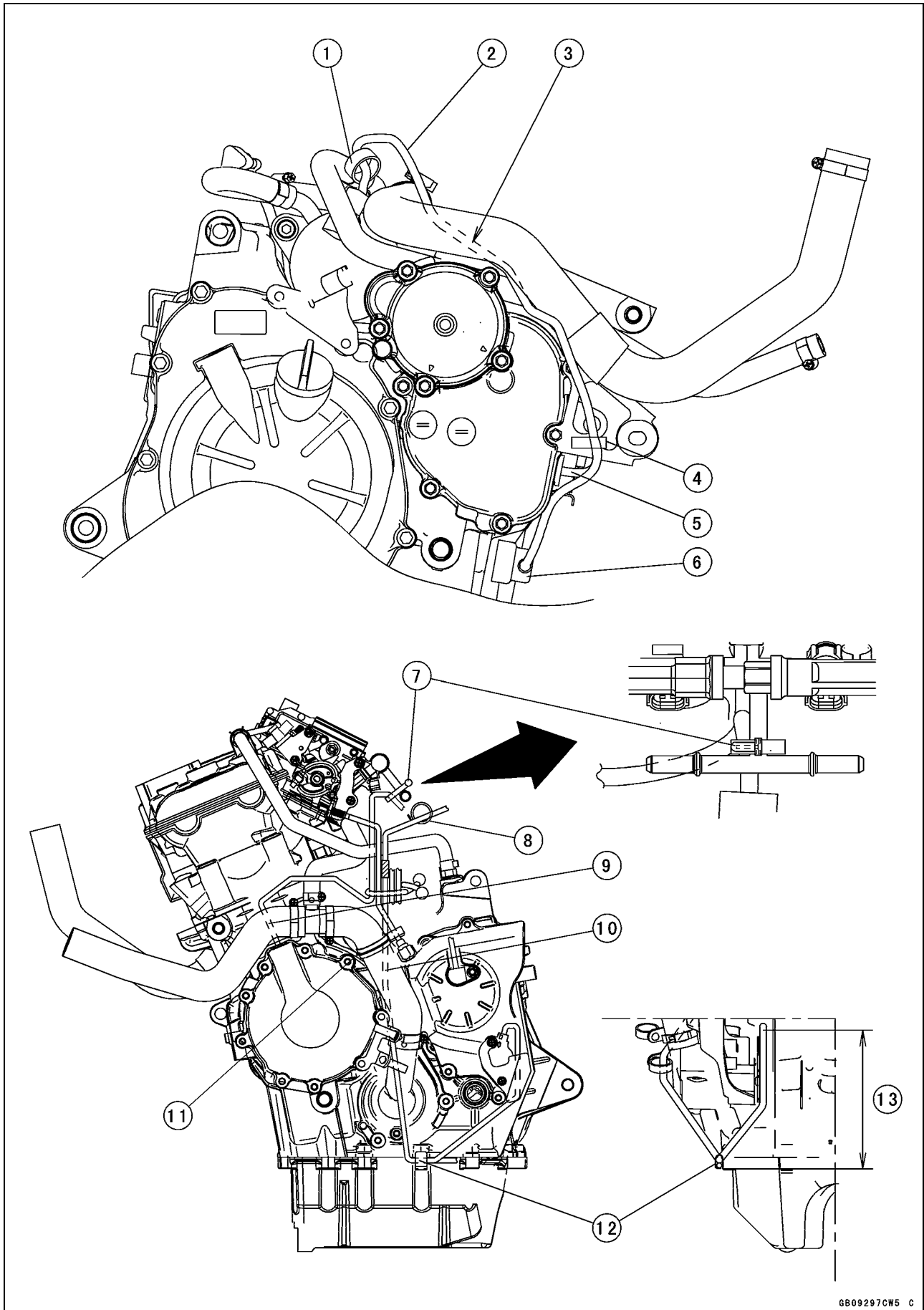



---

**Cable, Wire, and Hose Routing**

---

1. Clamp (Run the crankshaft sensor/oil pressure switch leads through the clamp as shown in the figure.)
2. Crankshaft sensor/oil pressure switch leads
3. Run the crankshaft sensor/oil pressure switch leads behind the water hose.
4. Clamp (Run the oil pressure switch and crankshaft sensor leads.)
5. Crankshaft Sensor Lead
6. Oil Pressure Switch
7. Clamp (Hold the alternator lead with delivery pipe of throttle body.)
8. Clamp (Run the gear position switch/sidestand switch leads through the clamp.)
9. Run the alternator lead between the water hose and engine.
10. Run the gear position switch/sidestand switch lead between the water hoses.
11. Clamp (Hold the idle adjusting screw cable.)
12. Clamp (Hold the gear position switch lead and sidestand switch lead.)
13. Do not loose the gear position switch lead in this area because of preventing for the drive chain to contact with the lead.

# 17-14 APPENDIX

## Cable, Wire, and Hose Routing

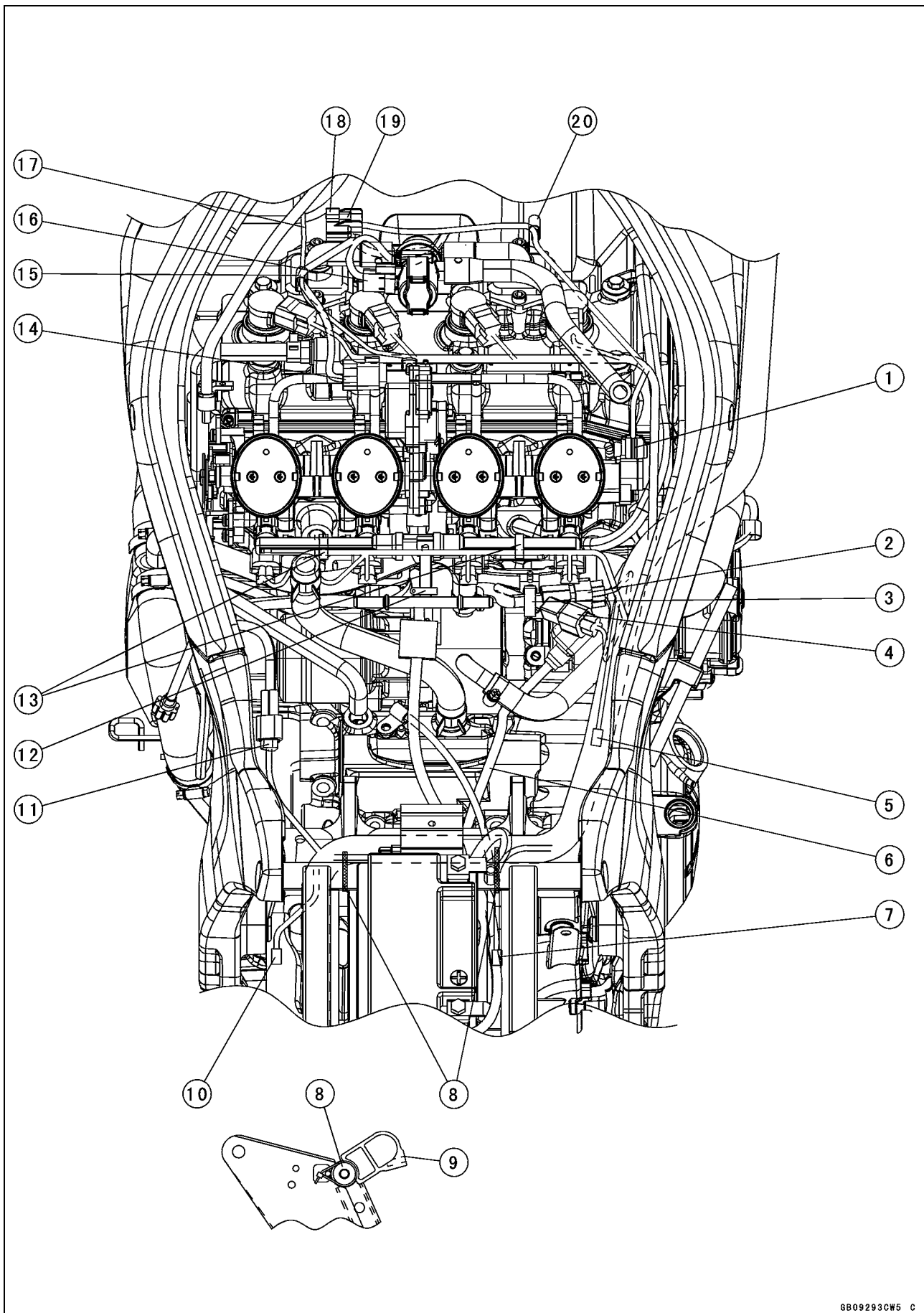

---

**Cable, Wire, and Hose Routing**

---

1. Throttle Sensor Connectors (upper side: Subthrottle Sensor, lower side: Main Throttle Sensor)
2. Gear Position Switch/Side Stand Switch Lead Connector
3. Clamp (Clamp the gear position switch lead and crankshaft sensor lead.)
4. Crankshaft Sensor Connector
5. Rear Brake Light Switch Lead Connector
6. Starter Motor Cable
7. Battery Negative Lead Connector
8. Clamps (Clamp the regulator/rectifier lead.)
9. Frame
10. Fuel Pump Lead Connector
11. Speed Sensor Connector
12. Clamp (Clamp the alternator lead.)
13. Clamps (Hold the primary fuel injector/water temperature sensor lead.)
14. Subthrottle Valve Actuator Connector
15. Clamp (Clamp the horn lead and subthrottle valve actuator lead.)
16. Air Switching Valve Connector
17. Horn Lead
18. Camshaft Position Sensor Connector
19. Bracket (Hold the camshaft position sensor lead connector.)
20. Clamp (Clamp the camshaft position sensor lead divided from the main harness.)

# 17-16 APPENDIX

## Cable, Wire, and Hose Routing

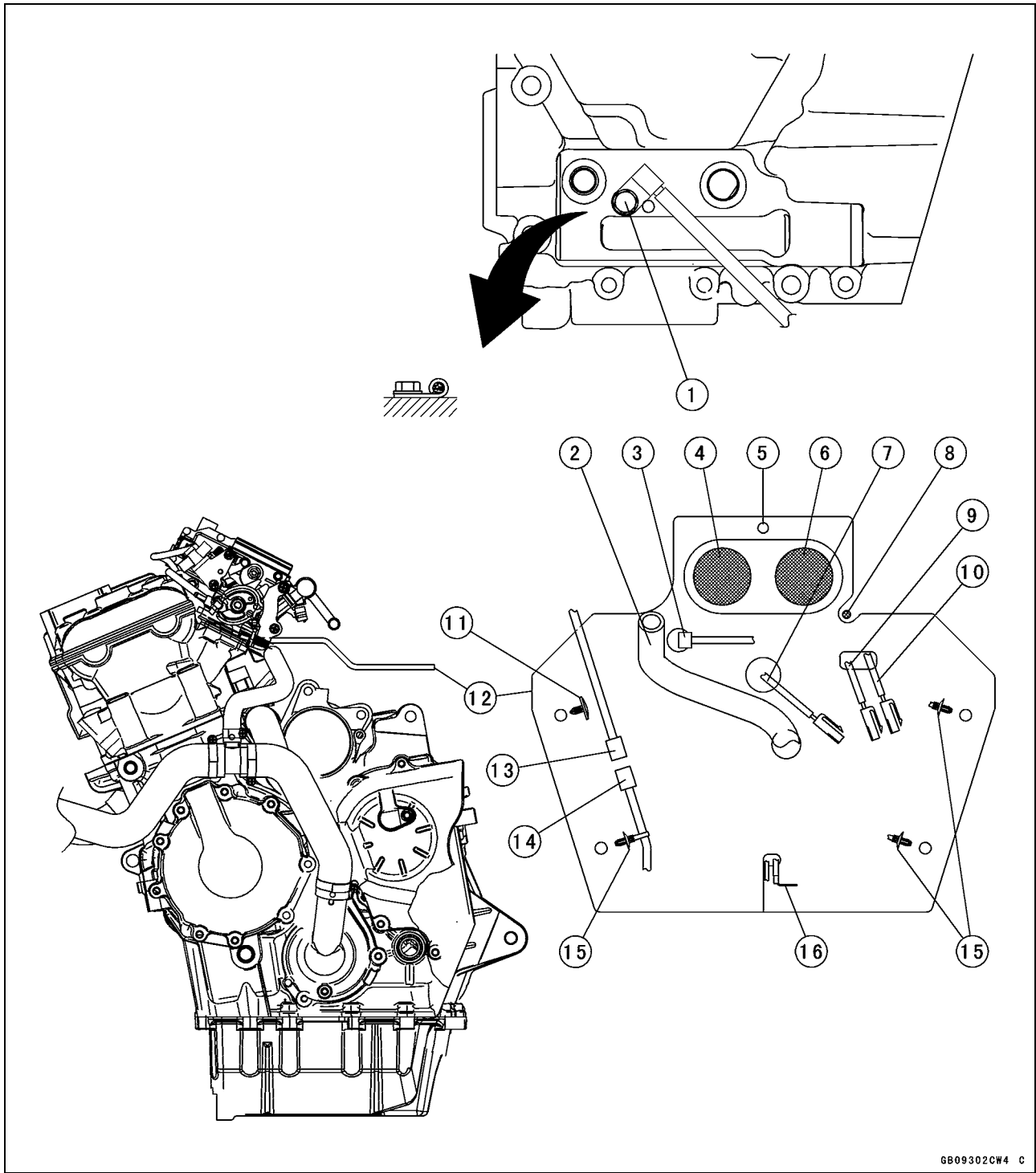

GB09302CW4 C

1. Install the engine ground terminal so that it touches to the stopper.
2. Blowby Gas Hose
3. Water Temperature Sensor Lead Connector
4. Throttle Body #2
5. Install the heat insulation rubber plate so that the white paint mark faces upward.
6. Throttle Body #3
7. Alternator Lead
8. Air Bleeder Hose to Thermostat Housing
9. Gear Position Switch/Sidestand Switch Leads.

10. Crankshaft Sensor/Oil Pressure Switch Leads
11. Rivet (Fix the heat insulation rubber plate to the frame.)
12. Heat Insulation Rubber Plate
13. Speed Sensor Lead Connector
14. Speed Sensor Lead Connector (Main Harness Side)
15. Clamp the Main Harness and fix the heat insulation rubber plate to the frame.
16. Run the starter motor cable and engine ground lead.

## Cable, Wire, and Hose Routing

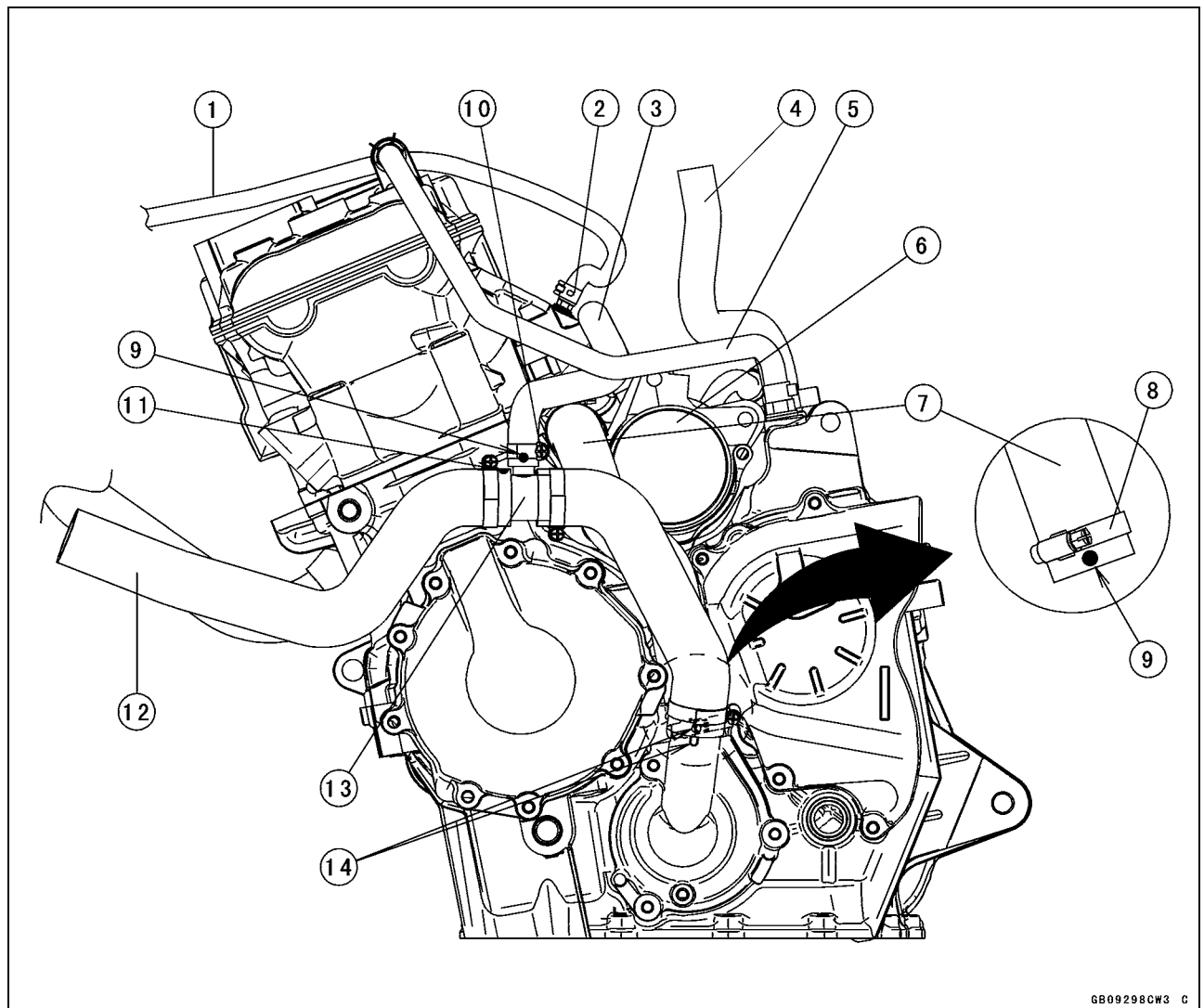

1. Air Bleeder Hose to Thermostat Housing
2. Install the clamp as shown in the figure.
3. Water Hose to Oil Cooler
4. Blowby Gas Hose
5. Breather Hose
6. Oil Filter
7. Water Hose
8. Install the clamp so that the screw head faces rearward.
9. Install the hose so that white paint mark faces to left side of the engine.
10. Install the clamp so that the screw head come to outside of the engine.
11. Install the hose so that white paint mark faces upward.
12. Water Hose
13. Water Pipe
14. Align the white paint mark of the hose with the projection on the water pump cover.

# 17-18 APPENDIX

## Cable, Wire, and Hose Routing

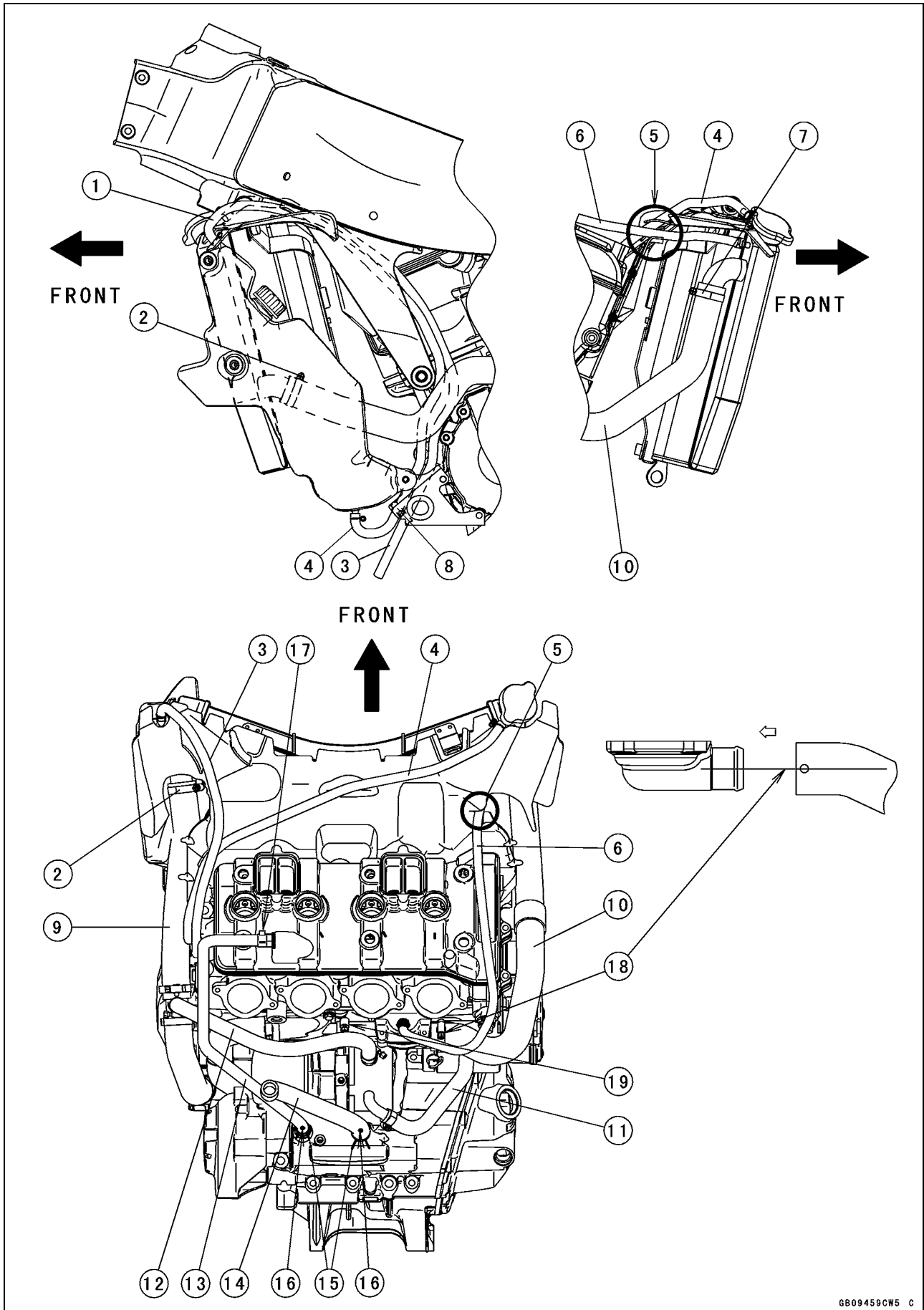

---

**Cable, Wire, and Hose Routing**

---

1. Run the breather hose to backward.
2. Install the clamp so that the clamp screw head faces upward as shown.
3. Reserve Tank Overflow Hose
4. Radiator Breather Hose
5. Run the hose through the slit of heat insulation rubber plate.
6. Air Bleeder Hose to Thermostat Housing
7. Install the clamp so that the clamp bolt head faces to right side as shown.
8. Insert the breather and overflow hoses into the inside of the fairing bracket.
9. Water Hose (supply)
10. Water Hose (return)
11. Water Hose to Oil Cooler (return)
12. Water Hose to Oil Cooler (supply)
13. Breather Hose (Install the hose as shown in the figure.)
14. Blowby Gas Hose (Install the hose as shown in the figure.)
15. Install the clamps so that the claw of it faces to rear side.
16. Install the hoses so that the white paint mark on them come to the rear side.
17. Install the clamp so that the claw of it faces upward.
18. Install the water hose (10) so that the white paint mark on the hose is parallel to the mating surface of the thermostat cover.
19. Install the water hose (11) so that the white paint mark on the hose is parallel to the mating surface of the fitting.

# 17-20 APPENDIX

## Cable, Wire, and Hose Routing

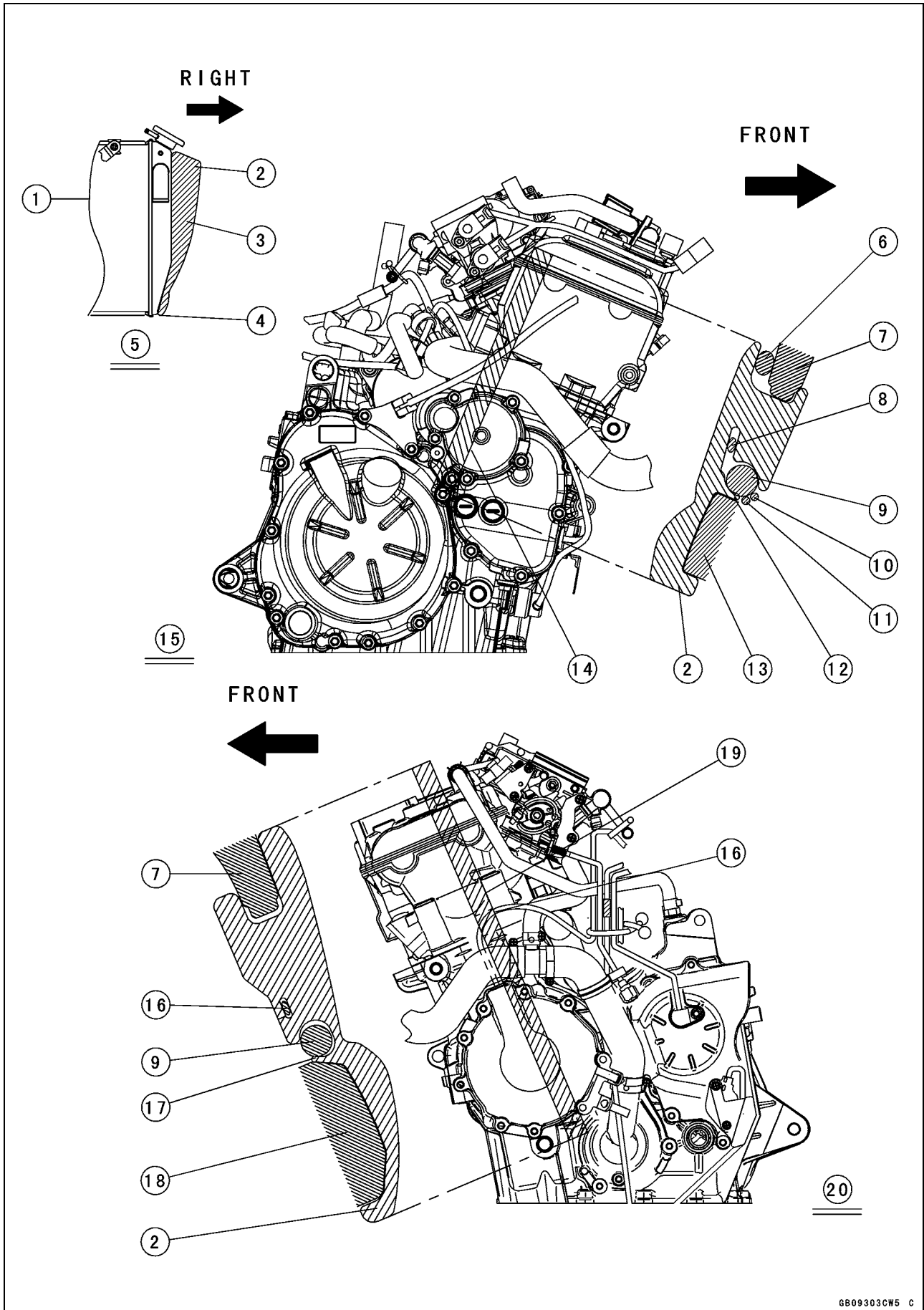



---

**Cable, Wire, and Hose Routing**

---

1. Radiator
2. Rubber Pads
3. Paste the rubber pad to the radiator along the shape of it.
4. Align the lower ends of the rubber pad and radiator.
5. Viewed from Rear of Frame
6. Main Harness
7. Frame
8. Clutch Cable
9. Water Hose
10. Crankshaft Sensor Lead
11. Oil Pressure Switch Lead
12. Put the projection of the rubber pad between the water hose and idle gear cover.
13. Idle Gear Cover
14. Fit the idle gear cover into the groove of the rubber pad at rear side of idle gear cover mounting bolt, and install it along the inclination of the cylinder.
15. Viewed from Right Side of Frame
16. Install the alternator lead through the slit of rubber pad.
17. Put the projection of the rubber pad between the water hose and alternator cover.
18. Alternator Cover
19. Install the rubber pad along the inclination of cylinder.
20. Viewed from Left Side of Frame

# 17-22 APPENDIX

## Cable, Wire, and Hose Routing

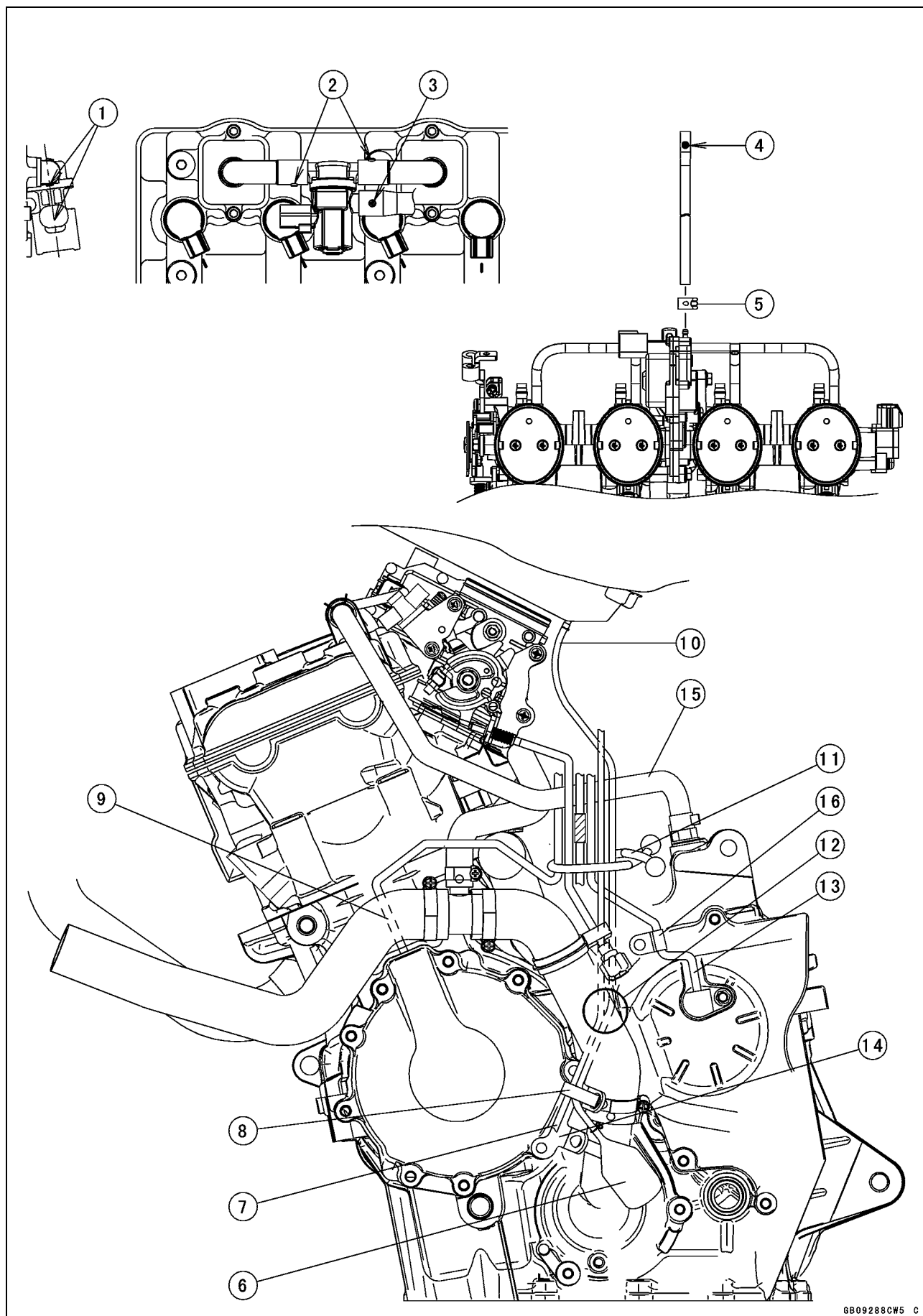

---

**Cable, Wire, and Hose Routing**

---

1. Align the projection [2] of the hose with the center line of the air switching valve.
2. Projection
3. Install the hose so that the white paint mark faces upward.
4. Large Outside Diameter Side (white paint)
5. Position the claw of the clamp right side of engine.
6. Catch Tank (Position the tank to rear side of the bracket.)
7. Fuel Tank Drain Hose
8. Clamp (Position the clamp to forward of the bracket.)
9. Run the alternator lead behind the breather hose
10. Air Cleaner Housing Drain Hose
11. Clamp (Hold the air cleaner housing drain hose, fuel tank drain hose, idle adjusting screw cable, speed sensor lead, side stand switch lead, alternator lead and gear position switch lead.)
12. Run the air cleaner drain hoses between two water hoses.
13. Speed Sensor Lead
14. Bracket
15. Breather Hose
16. Clamp

## 17-24 APPENDIX

### Cable, Wire, and Hose Routing

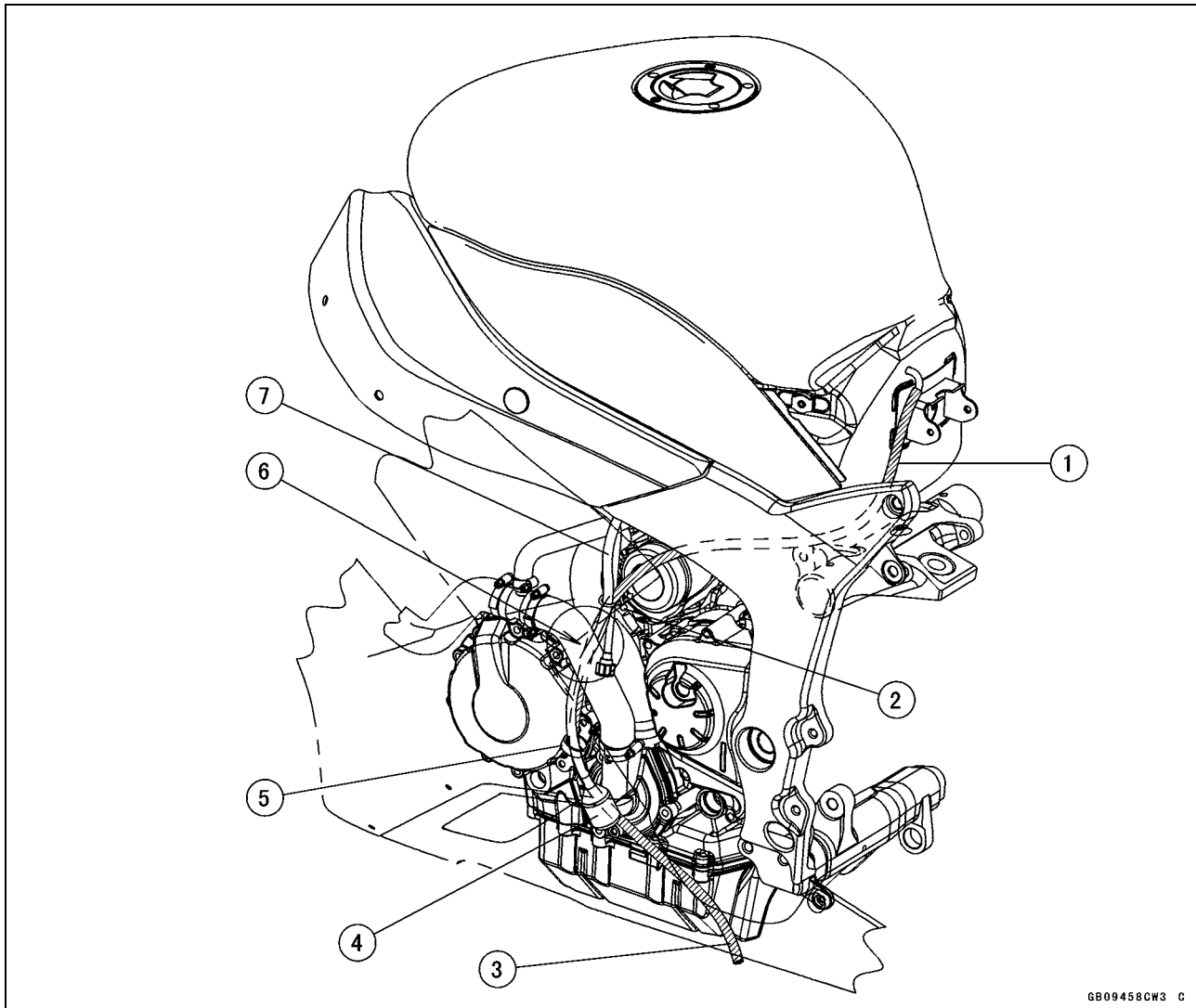

1. Drain Hose (Fuel Tank)
2. Clamp (Hold the drain hoses.)
3. Run the fuel tank drain hose through out from the left lower fairing (exposed length is about 40 ~ 50 mm (1.6 ~ 2.0 in.)).
4. Catch Tank (Position the tank rear side of the bracket.)
5. Clamp (Run the through drain hose.)
6. Run the hoses between the water hoses.
7. Drain Hose (Air Cleaner Housing)

Cable, Wire, and Hose Routing

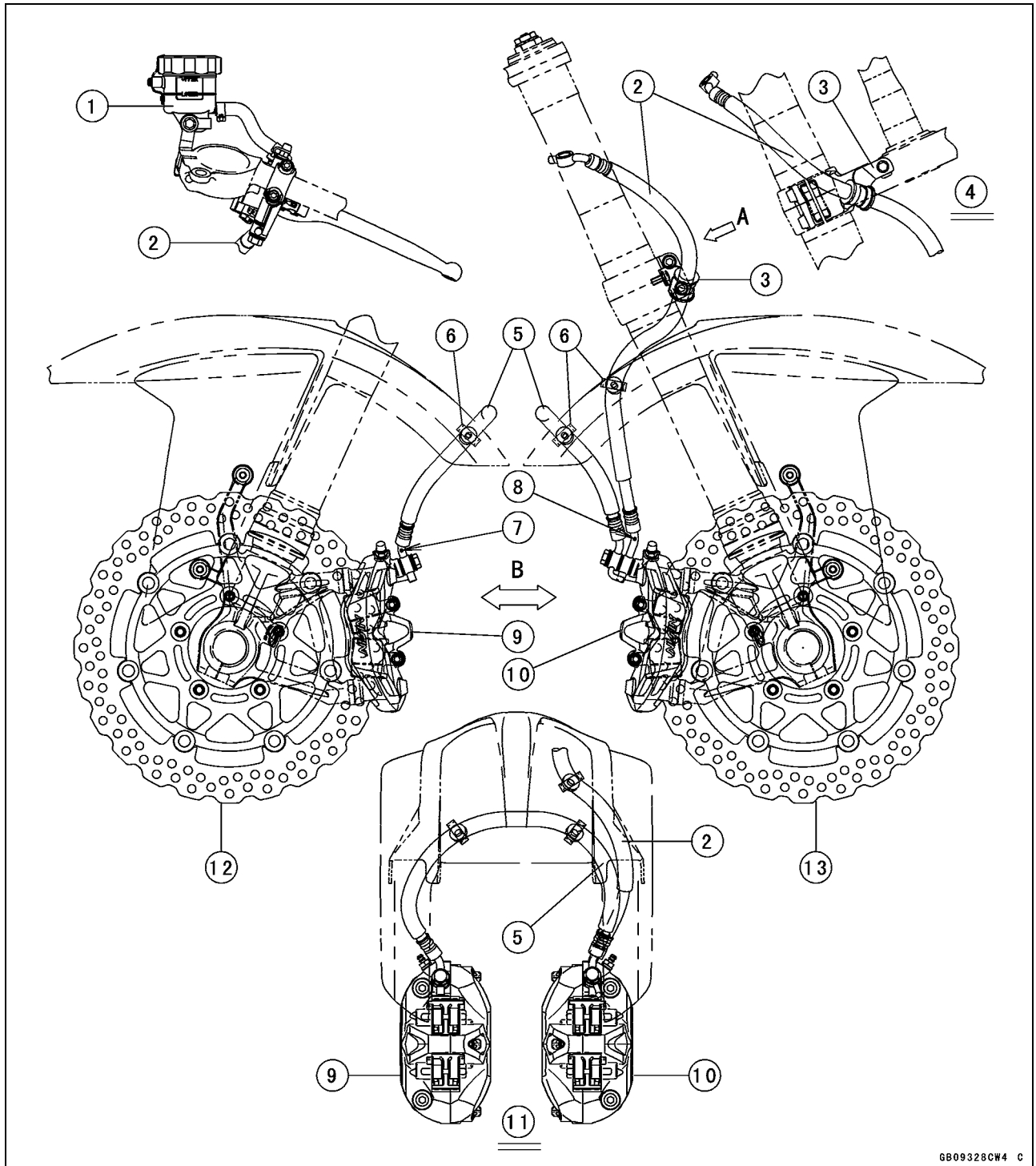

GB09328CW4 C

1. Front Brake Reservoir
2. Brake Hose
3. Clamp
4. Viewed from A
5. Brake Hoses
6. Clamps
7. Blue Paint Mark
8. White Paint Mark
9. Left Front Caliper
10. Right Front Caliper
11. Viewed from B
12. Left Front Disc
13. Right Front Disc

## 17-26 APPENDIX

### Cable, Wire, and Hose Routing

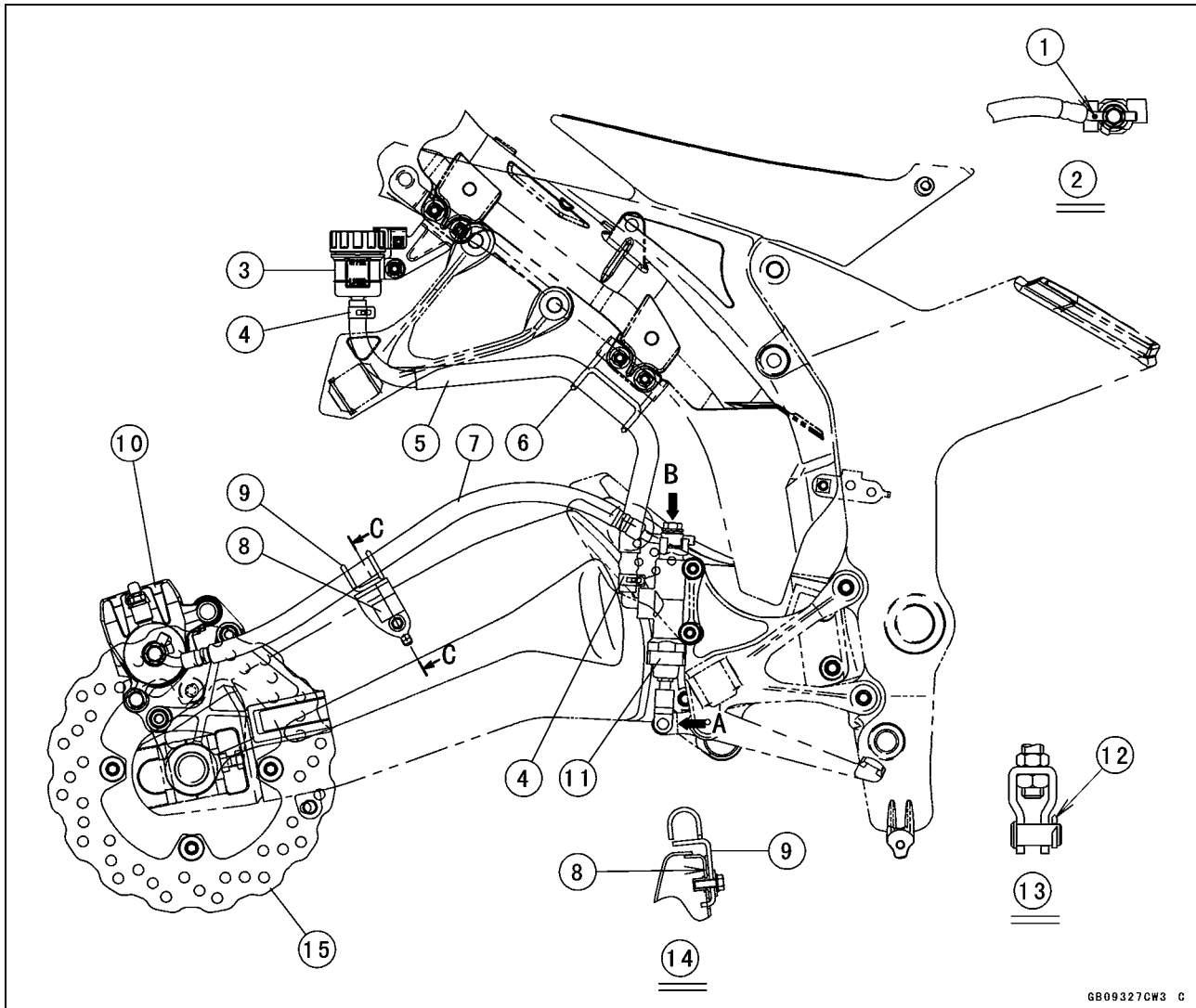

6B09327CW3 C

1. White Paint Mark
2. Viewed from B
3. Rear Brake Reservoir
4. Clamps
5. Brake Hose
6. Clamps
7. Brake Hose
8. Pad (stick on)
9. Clamp
10. Rear Caliper
11. Rear Brake Master Cylinder
12. Cotter Pin (Bend the tip of the pin surely.)
13. Viewed from A
14. Section C-C
15. Rear Disc

Cable, Wire, and Hose Routing

California Model

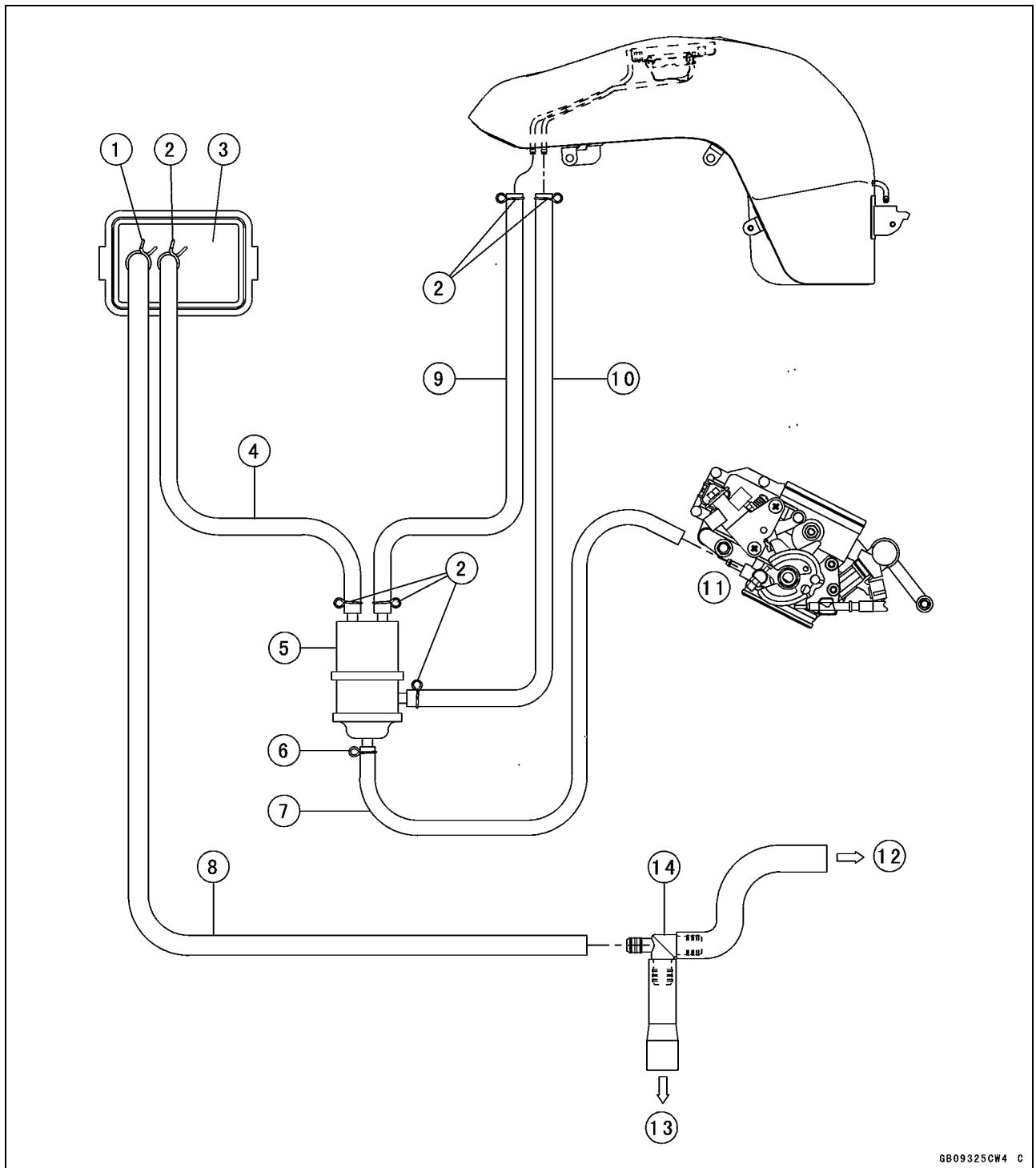

GB09325CW4 C

- |                         |                                     |
|-------------------------|-------------------------------------|
| 1. Clamp                | 8. Purge Hose (Green)               |
| 2. Clamps               | 9. Breather Hose (Blue)             |
| 3. Canister             | 10. Return Hose (Red)               |
| 4. Breather Hose (Blue) | 11. Fitting of the throttle body #1 |
| 5. Separator            | 12. To the air cleaner housing.     |
| 6. Clamp                | 13. To the air switching valve.     |
| 7. Vacuum Hose (White)  | 14. Fitting                         |

# 17-28 APPENDIX

## Cable, Wire, and Hose Routing

### California Model

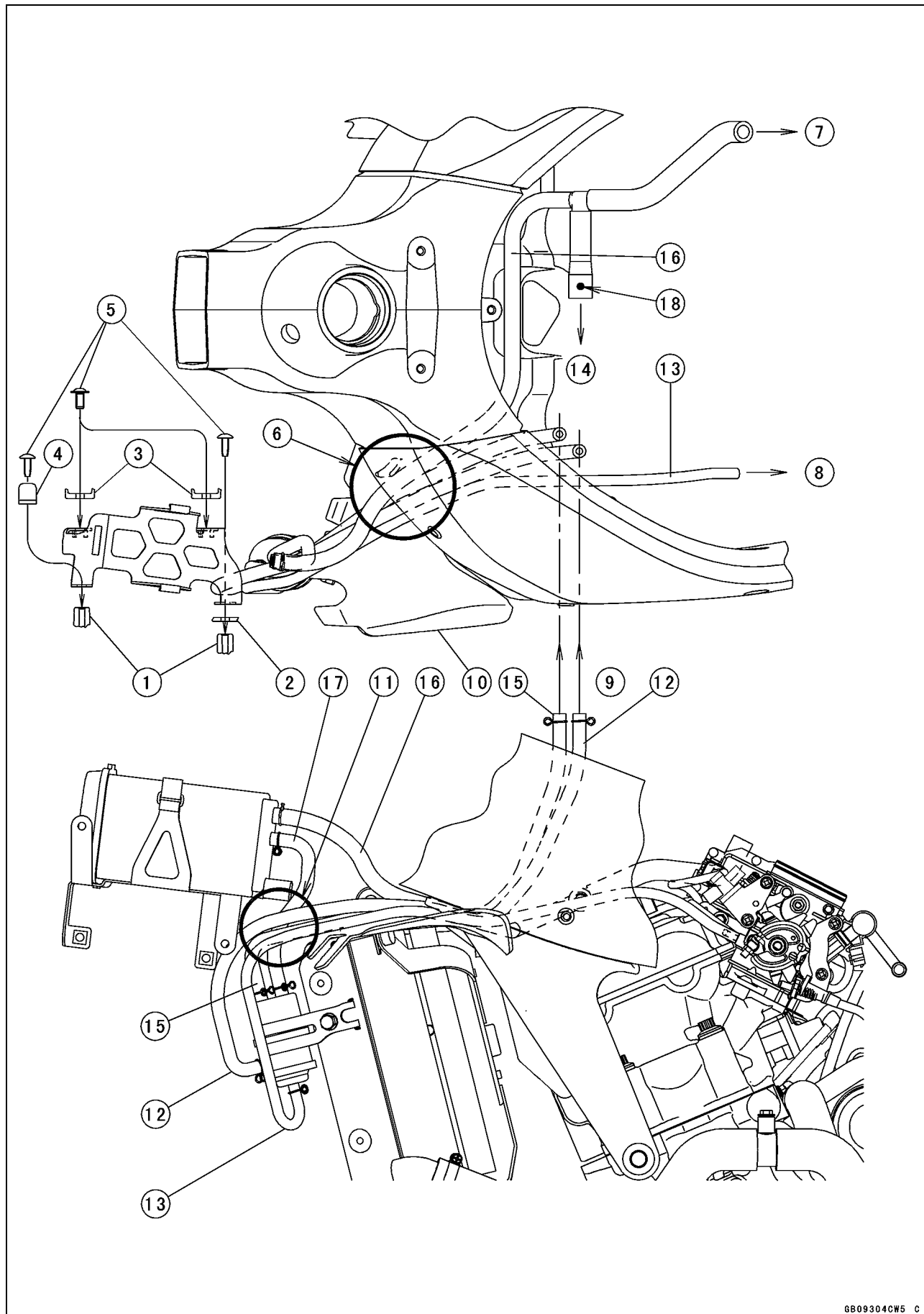



---

**Cable, Wire, and Hose Routing**

---

1. Left Middle Fairing
2. Left Turn Signal Light
3. Left Inner Cover
4. Clamp
5. Screws
6. Run the hoses between the frame and rib of the heat insulation plate as shown.
7. To the air cleaner housing.
8. To the fitting of the throttle body #1.
9. To the fuel tank.
10. Heat Insulation Plate
11. Run the hoses [12] [13] [15] through outside of the hose [17] as shown.
12. Return Hose (Red)
13. Vacuum Hose (White)
14. To the air switching valve.
15. Breather Hose (Blue)
16. Purge Hose (Green)
17. BreatherHose (Blue)
18. Install the hose so that the white paint mark faces upward.

## 17-30 APPENDIX

### Troubleshooting Guide

---

#### NOTE

- Refer to the *Fuel System* chapter for most of DFI trouble shooting guide.
- This is not an exhaustive list, giving every possible cause for each problem listed. It is meant simply as a rough guide to assist the troubleshooting for some of the more common difficulties.

#### Engine Doesn't Start, Starting Difficulty:

##### Starter motor not rotating:

- Ignition and engine stop switch not ON
- Starter lockout switch or gear position switch trouble
- Starter motor trouble
- Battery voltage low
- Starter relay not contacting or operating
- Starter button not contacting
- Starter system wiring open or shorted
- Ignition switch trouble
- Engine stop switch trouble
- Main 30A or ignition fuse blown

##### Starter motor rotating but engine doesn't turn over:

- Vehicle-down sensor (DFI) coming off
- Immobilizer system trouble
- Starter clutch trouble
- Starter idle gear trouble

##### Engine won't turn over:

- Valve seizure
- Valve lifter seizure
- Cylinder, piston seizure
- Crankshaft seizure
- Connecting rod small end seizure
- Connecting rod big end seizure
- Transmission gear or bearing seizure
- Camshaft seizure
- Starter idle gear seizure

##### No fuel flow:

- No fuel in tank
- Fuel pump trouble
- Fuel tank air vent obstructed
- Fuel filter clogged
- Fuel line clogged

##### No spark; spark weak:

- Vehicle-down sensor (DFI) coming off
- Ignition switch not ON
- Engine stop switch turned OFF
- Clutch lever not pulled in or gear not in neutral
- Battery voltage low
- Immobilizer system trouble
- Spark plug dirty, broken, or gap maladjusted
- Spark plug incorrect
- Stick coil shorted or not in good contact

- Stick coil trouble
- ECU trouble
- Camshaft position sensor trouble
- Gear position, starter lockout, or side stand switch trouble
- Crankshaft sensor trouble
- Ignition switch or engine stop switch shorted
- Starter system wiring shorted or open
- Main 30A or ignition fuse blown

##### Fuel/air mixture incorrect:

- Bypass screw and/or idle adjusting screw maladjusted
- Air passage clogged
- Air cleaner clogged, poorly sealed, or missing
- Leak from oil filler cap, crankcase breather hose or air cleaner drain hose.

##### Compression Low:

- Spark plug loose
- Cylinder head not sufficiently tightened down
- Cylinder, piston worn
- Piston ring bad (worn, weak, broken, or sticking)
- Piston ring/groove clearance excessive
- Cylinder head gasket damaged
- Cylinder head warped
- Valve spring broken or weak
- No valve clearance
- Valve not seating properly (valve bent, worn, or carbon accumulation on the seating surface)

#### Poor Running at Low Speed:

##### Spark weak:

- Battery voltage low
- Immobilizer system trouble
- Stick coil trouble
- Stick coil shorted or not in good contact
- Spark plug dirty, broken, or maladjusted
- Spark plug incorrect
- ECU trouble
- Camshaft position sensor trouble
- Crankshaft sensor trouble

##### Fuel/air mixture incorrect:

- Bypass screw maladjusted
- Air passage clogged
- Air bleed pipe bleed holes clogged
- Pilot passage clogged
- Air cleaner clogged, poorly sealed, or missing
- Fuel tank air vent obstructed
- Fuel pump trouble
- Throttle body assy holder loose
- Air cleaner housing holder loose

## Troubleshooting Guide

### Compression low:

- Spark plug loose
- Cylinder head not sufficiently tightened down
- No valve clearance
- Cylinder, piston worn
- Piston ring bad (worn, weak, broken, or sticking)
- Piston ring/groove clearance excessive
- Cylinder head gasket damaged
- Cylinder head warped
- Valve spring broken or weak
- Valve not seating properly (valve bent, worn, or carbon accumulation on the seating surface)
- Camshaft cam worn

### Run-on (dieseling):

- Ignition switch trouble
- Engine stop switch trouble
- Fuel injector trouble
- Loosen terminal of battery (–) cable or ECU ground lead
- Carbon accumulating on valve seating surface
- Engine overheating

### Other:

- ECU trouble
- Engine vacuum not synchronizing
- Engine oil viscosity too high
- Drive train trouble
- Brake dragging
- Clutch slipping
- Engine overheating
- Air suction valve trouble
- Air switching valve trouble

### Poor Running or No Power at High Speed:

#### Firing incorrect:

- Spark plug dirty, broken, or maladjusted
- Spark plug incorrect
- Stick coil shorted or not in good contact trouble
- Stick coil trouble
- ECU trouble

#### Fuel/air mixture incorrect:

- Air cleaner clogged, poorly sealed, or missing
- Air cleaner housing holder loose
- Water or foreign matter in fuel
- Throttle body assy holder loose
- Fuel to injector insufficient
- Fuel tank air vent obstructed
- Fuel line clogged
- Fuel pump trouble

### Compression low:

- Spark plug loose

- Cylinder head not sufficiently tightened down
- No valve clearance
- Cylinder, piston worn
- Piston ring bad (worn, weak, broken, or sticking)
- Piston ring/groove clearance excessive
- Cylinder head gasket damaged
- Cylinder head warped
- Valve spring broken or weak
- Valve not seating properly (valve bent, worn, or carbon accumulation on the seating surface.)

### Knocking:

- Carbon built up in combustion chamber
- Fuel poor quality or incorrect
- Spark plug incorrect
- ECU trouble

### Miscellaneous:

- Throttle valve won't fully open
- Brake dragging
- Clutch slipping
- Engine overheating
- Engine oil level too high
- Engine oil viscosity too high
- Drive train trouble
- Camshaft cam worn
- Air suction valve trouble
- Air switching valve trouble
- Catalytic converter melt down due to muffler overheating (KLEEN)

### Overheating:

#### Firing incorrect:

- Spark plug dirty, broken, or maladjusted
- Spark plug incorrect
- ECU trouble

#### Muffler overheating:

For KLEEN, do not run the engine even if with only one cylinder misfiring or poor running (Request the nearest service facility to correct it)

For KLEEN, do not push-start with a dead battery (Connect another full-charged battery with jumper cables, and start the engine using the electric starter)

For KLEEN, do not start the engine under misfire due to spark plug fouling or poor connection of the stick coil

For KLEEN, do not coast the motorcycle with the ignition switch off (Turn the ignition switch ON and run the engine)

- ECU trouble

#### Fuel/air mixture incorrect:

- Throttle body assy holder loose
- Air cleaner housing holder loose
- Air cleaner poorly sealed, or missing

## 17-32 APPENDIX

### Troubleshooting Guide

---

Air cleaner clogged

#### **Compression high:**

Carbon built up in combustion chamber

#### **Engine load faulty:**

Clutch slipping

Engine oil level too high

Engine oil viscosity too high

Drive train trouble

Brake dragging

#### **Lubrication inadequate:**

Engine oil level too low

Engine oil poor quality or incorrect

#### **Oil cooler incorrect:**

Oil cooler clogged

#### **Water temperature meter incorrect:**

Water temperature meter broken

Water temperature sensor broken

#### **Coolant incorrect:**

Coolant level too low

Coolant deteriorated

Wrong coolant mixed ratio

#### **Cooling system component incorrect:**

Radiator fin damaged

Radiator clogged

Thermostat trouble

Radiator cap trouble

Radiator fan relay trouble

Fan motor broken

Fan blade damaged

Water pump not turning

Water pump impeller damaged

#### **Over Cooling:**

##### **Water temperature meter incorrect:**

Water temperature meter broken

Water temperature sensor broken

##### **Cooling system component incorrect:**

Thermostat trouble

#### **Clutch Operation Faulty:**

##### **Clutch slipping:**

Friction plate worn or warped

Steel plate worn or warped

Clutch spring broken or weak

Clutch hub or housing unevenly worn

No clutch lever play

Clutch inner cable trouble

Clutch release mechanism trouble

##### **Clutch not disengaging properly:**

Clutch plate warped or too rough

Clutch spring compression uneven

Engine oil deteriorated

Engine oil viscosity too high

Engine oil level too high

Clutch housing frozen on drive shaft

Clutch hub nut loose

Clutch hub spline damaged

Clutch friction plate installed wrong

Clutch lever play excessive

Clutch release mechanism trouble

#### **Gear Shifting Faulty:**

##### **Doesn't go into gear; shift pedal doesn't return:**

Clutch not disengaging

Shift fork bent or seized

Gear stuck on the shaft

Gear positioning lever binding

Shift return spring weak or broken

Shift return spring pin loose

Shift mechanism arm spring broken

Shift mechanism arm broken

Shift pawl broken

##### **Jumps out of gear:**

Shift fork ear worn, bent

Gear groove worn

Gear dogs and/or dog holes worn

Shift drum groove worn

Gear positioning lever spring weak or broken

Shift fork guide pin worn

Drive shaft, output shaft, and/or gear splines worn

##### **Overshifts:**

Gear positioning lever spring weak or broken

Shift mechanism arm spring broken

#### **Abnormal Engine Noise:**

##### **Knocking:**

ECU trouble

Carbon built up in combustion chamber

Fuel poor quality or incorrect

Spark plug incorrect

Overheating

##### **Piston slap:**

Cylinder/piston clearance excessive

Cylinder, piston worn

Connecting rod bent

Piston pin, piston pin hole worn

##### **Valve noise:**

Valve clearance incorrect

Valve spring broken or weak

Camshaft bearing worn

Valve lifter worn

##### **Other noise:**

Connecting rod small end clearance excessive

Connecting rod big end clearance excessive

Piston ring/groove clearance excessive

Piston ring worn, broken, or stuck

Piston ring groove worn

Piston seizure, damage

## Troubleshooting Guide

Cylinder head gasket leaking  
 Exhaust pipe leaking at cylinder head connection  
 Crankshaft runout excessive  
 Engine mount loose  
 Crankshaft bearing worn  
 Primary gear worn or chipped  
 Camshaft chain tensioner trouble  
 Camshaft chain, sprocket, guide worn  
 Air suction valve damaged  
 Air switching valve damaged  
 Alternator rotor loose  
 Catalytic converter melt down due to muffler overheating (KLEEN)

### Abnormal Drive Train Noise:

#### Clutch noise:

Clutch damper weak or damaged  
 Clutch housing/friction plate clearance excessive  
 Clutch housing gear worn  
 Wrong installation of outside friction plate

#### Transmission noise:

Bearings worn  
 Transmission gear worn or chipped  
 Metal chips jammed in gear teeth  
 Engine oil insufficient

#### Drive line noise:

Drive chain adjusted improperly  
 Drive chain worn  
 Rear and/or engine sprocket worn  
 Chain lubrication insufficient  
 Rear wheel misaligned

### Abnormal Frame Noise:

#### Front fork noise:

Oil insufficient or too thin  
 Spring weak or broken

#### Rear shock absorber noise:

Shock absorber damaged

#### Disc brake noise:

Pad installed incorrectly  
 Pad surface glazed  
 Disc warped  
 Caliper trouble

#### Other noise:

Bracket, nut, bolt, etc. not properly mounted or tightened

### Warning Indicator Light (Oil Pressure Warning) Doesn't Go OFF:

Engine oil pump damaged  
 Engine oil screen clogged  
 Engine oil filter clogged  
 Engine oil level too low  
 Engine oil viscosity too low

Camshaft bearing worn  
 Crankshaft bearing worn  
 Oil pressure switch damaged  
 Wiring faulty  
 Relief valve stuck open  
 O-ring at the oil passage in the crankcase damaged

### Exhaust Smokes Excessively:

#### White smoke:

Piston oil ring worn  
 Cylinder worn  
 Valve oil seal damaged  
 Valve guide worn  
 Engine oil level too high

#### Black smoke:

Air cleaner clogged

#### Brown smoke:

Air cleaner housing holder loose  
 Air cleaner poorly sealed or missing

### Handling and/or Stability

#### Unsatisfactory:

##### Handlebar hard to turn:

Cable routing incorrect  
 Hose routing incorrect  
 Wiring routing incorrect  
 Steering stem nut too tight  
 Steering stem bearing damaged  
 Steering stem bearing lubrication inadequate  
 Steering stem bent  
 Tire air pressure too low

##### Handlebar shakes or excessively vibrates:

Tire worn  
 Swingarm pivot bearing worn  
 Rim warped, or not balanced  
 Wheel bearing worn  
 Handlebar holder bolt loose  
 Steering stem nut loose  
 Front, rear axle runout excessive  
 Engine loose

##### Handlebar pulls to one side:

Frame bent  
 Wheel misalignment  
 Swingarm bent or twisted  
 Swingarm pivot shaft runout excessive  
 Steering maladjusted  
 Front fork bent  
 Right and left front fork oil level uneven

##### Shock absorption unsatisfactory:

(Too hard)  
 Front fork oil excessive  
 Front fork oil viscosity too high  
 Rear shock absorber adjustment too hard  
 Tire air pressure too high  
 Front fork bent

## 17-34 APPENDIX

---

### Troubleshooting Guide

---

(Too soft)

Tire air pressure too low

Front fork oil insufficient and/or leaking

Front fork oil viscosity too low

Rear shock adjustment too soft

Front fork, rear shock absorber spring weak

Rear shock absorber oil leaking

#### **Brake Doesn't Hold:**

Air in the brake line

Pad or disc worn

Brake fluid leakage

Disc warped

Contaminated pad

Brake fluid deteriorated

Primary or secondary cup damaged in master cylinder

Master cylinder scratched inside

#### **Battery Trouble:**

##### **Battery discharged:**

Charge insufficient

Battery faulty (too low terminal voltage)

Battery cable making poor contact

Load excessive (e.g., bulb of excessive wattage)

Ignition switch trouble

Alternator trouble

Wiring faulty

Regulator/rectifier trouble

##### **Battery overcharged:**

Alternator trouble

Regulator/rectifier trouble

Battery faulty

## MODEL APPLICATION

Year	Model	Beginning Frame No.
2007	ZX600P7F	JKAZX4P1□7A000001 JKAZX600PPA000001 ZX600P-000001
2008	ZX600P8F	JKAZX4P1□8A035001 JKAZX600PPA035001 ZX600P-035001

□: This digit in the frame number changes from one machine to another.



KAWASAKI HEAVY INDUSTRIES, LTD.  
Consumer Products & Machinery Company

Part No.99924-1382-02

Printed in Japan